

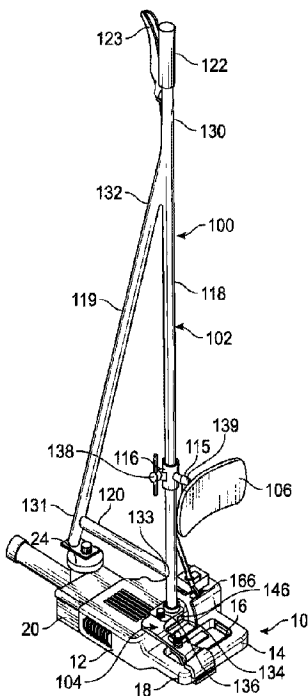

(22) Date de dépôt/Filing Date: 2017/08/15  
(41) Mise à la disp. pub./Open to Public Insp.: 2018/04/25  
(45) Date de délivrance/Issue Date: 2023/01/24  
(30) Priorité/Priority: 2016/10/25 (US15/333,366)

(51) Cl.Int./Int.Cl. *B23B 45/14* (2006.01),  
*B23B 45/00* (2006.01), *B23B 47/00* (2006.01)  
(72) Inventeurs/Inventors:  
MOORE, BRUCE, US;  
HOWLAND, SHANNON L., US  
(73) Propriétaire/Owner:  
BACKSAVER 2005, LLC, US  
(74) Agent: GOWLING WLG (CANADA) LLP

(54) Titre : ACCESSOIRE DE FORAGE DOTE D'UNE COMPOSANTE D'ADAPTATEUR  
(54) Title: DRILL ATTACHMENT HAVING AN ADAPTER COMPONENT



(57) **Abrégé/Abstract:**

A drill attachment for engagement and actuation of a drill apparatus having a bifurcated frame defining a first shaft and a second shaft operatively engaged to the drill apparatus at first and second engagement points is disclosed. A handle is pivotally engaged to the first shaft and is operatively coupled to a trigger actuator located along the first shaft through a trigger cable operatively engaged to a trigger actuator the distal end of the first shaft that permits remote actuation of the drill apparatus. The trigger actuator includes a pivotable rocking arm having an actuator pad in selective engagement with the drill trigger such that actuation of the handle by the user pivots the rocking arm in a manner that causes the actuator pad to engage or disengage the drill trigger when operating the drill apparatus. The drill attachment is operatively engaged to the drill apparatus through an adapter component having a proximal portion engaged to the drill attachment and a distal portion defining a generally curved configuration adapted to engage the handle of any conventional drill apparatus.

## **ABSTRACT**

A drill attachment for engagement and actuation of a drill apparatus having a bifurcated frame defining a first shaft and a second shaft operatively engaged to the drill apparatus at first and second engagement points is disclosed. A handle is pivotally engaged to the first shaft and is operatively coupled to a trigger actuator located along the first shaft through a trigger cable operatively engaged to a trigger actuator the distal end of the first shaft that permits remote actuation of the drill apparatus. The trigger actuator includes a pivotable rocking arm having an actuator pad in selective engagement with the drill trigger such that actuation of the handle by the user pivots the rocking arm in a manner that causes the actuator pad to engage or disengage the drill trigger when operating the drill apparatus. The drill attachment is operatively engaged to the drill apparatus through an adapter component having a proximal portion engaged to the drill attachment and a distal portion defining a generally curved configuration adapted to engage the handle of any conventional drill apparatus.

## **DRILL ATTACHMENT HAVING AN ADAPTER COMPONENT**

### **FIELD**

**[0001]** The present disclosure generally relates to drill attachments, and more particularly to drill attachments having an adapter component for operatively engaging the drill attachment to a drill apparatus.

### **BACKGROUND**

**[0002]** Drill apparatuses, such as hammer drills, are commonly used to drill holes in concrete and other materials during construction activity. In one particular use, a hammer drill may be used to drill holes along an end of a concrete slab by laying the hammer drill on the floor adjacent the concrete slab, abutting the hammer drill to the concrete slab, and drilling a sequence of holes along the end of the concrete slab while maintaining an abutting relationship between the concrete slab and the hammer drill. However, the process of drilling holes with a hammer drill in this manner can be physically exhausting and uncomfortable since the user must sit or kneel down for long periods of time while handling the hammer drill in a manner that ensures that the hammer drill is maintained in the proper orientation during operation. To solve this issue, U.S. Patent No. 7,617,885 to Shannon L. Howland discloses a drill attachment that is operable to secure and operate a conventional drill apparatus. In particular, the drill attachment of Howland requires that the drilling apparatus have the appropriate engagement points to allow the drill attachment to establish a secure and operative engagement between the drill attachment and the drill apparatus. However, drill apparatuses are manufactured by different manufacturers, thereby making it difficult to properly engage the drill attachment to different types of drill apparatuses if the drill attachment lacks both engagement points. Accordingly, a drill attachment is needed that allows the drill attachment to be attached to different types of drill apparatuses regardless of configuration of the drill apparatus.

## **BRIEF DESCRIPTION OF THE DRAWINGS**

**[0003]** FIG. 1 is a perspective view of a drill attachment operatively engaged to a drill apparatus, according to aspects of the present disclosure;

**[0004]** FIG. 2 is an exploded view of the drill attachment and drill apparatus of FIG. 1, according to aspects of the present disclosure;

**[0005]** FIG. 3 is a side view of the drill attachment of FIG. 1, according to aspects of the present disclosure;

**[0010]** FIG. 4 is an opposite side view of the drill attachment of FIG. 3, according to aspects of the present disclosure;

**[0011]** FIG. 5 is a front view of the drill attachment of FIG. 3, according to aspects of the present disclosure;

**[0012]** FIG. 6 is a rear view of the drill attachment of FIG. 3, according to aspects of the present disclosure;

**[0013]** FIG. 7 is an enlarged view showing the engagement of an adapter component between the drill attachment and the drill apparatus, according to aspects of the present disclosure;

**[0014]** FIG. 8 is another enlarged view showing the engagement of the adapter component illustrated in FIG. 7, according to aspects of the present disclosure;

**[0015]** FIG. 9 is a perspective view of the adapter component used to engage the drill attachment to the drill apparatus, according to aspects of the present disclosure;

**[0016]** FIG. 10 is an end view of the adapter component of FIG. 9, according to aspects of the present disclosure;

**[0017]** FIG. 11 is an opposite end view of the adapter component of FIG. 9, according to aspects of the present disclosure;

**[0018]** FIG. 12 is a top view of the adapter component of FIG. 9, according to aspects of the present disclosure;

**[0019]** FIG. 13 is an exploded view of the adapter component of FIG. 9, according to aspects of the present disclosure;

**[0020]** FIG. 14 is an enlarged side view of a trigger actuator and adapter component for the drill attachment, according to aspects of the present disclosure;

**[0021]** FIG. 15 is a partial cross sectional side view of the drill attachment showing the actuation of a handle for the drill attachment, according to aspects of the present disclosure;

**[0022]** FIG. 16 is a partial cross sectional side view of the drill attachment showing the actuation of the trigger actuator by the handle shown in FIG. 15, according to aspects of the present disclosure;

**[0023]** FIG. 17 is a perspective view of a second embodiment of the drill attachment showing another embodiment of an adapter component disengaged from the drill apparatus, according to aspects of the present disclosure;

**[0024]** FIG. 18 is a perspective view of the drill attachment of FIG. 17 showing the adapter component engaged to the drill apparatus, according to aspects of the present disclosure;

**[0025]** FIG. 19 is a side view of the drill attachment of FIG. 17, according to aspects of the present disclosure;

**[0026]** FIG. 20 is an opposite side view of the drill attachment of FIG. 17, according to aspects of the present disclosure;

**[0027]** FIG. 21 is a front view of the drill attachment of FIG. 17, according to aspects of the present disclosure;

**[0028]** FIG. 22 is a rear view of the drill attachment of FIG. 17, according to aspects of the present disclosure;

**[0029]** FIG. 23 is a side view of the adapter component of FIG. 17, according to aspects of the present disclosure;

**[0030]** FIG. 24 is an end view of the adapter component of FIG. 23;

**[0031]** FIG. 25 is an opposite end view of the adapter component of FIG. 23;

**[0032]** FIG. 26 is a an top view of the adapter component of FIG. 23;

**[0033]** FIG. 27 is a bottom view of the adapter component of FIG. 23; and

**[0034]** FIG. 28 is a perspective view of the drill attachment showing the adapter component being integral with the drill attachment.

**[0035]** Corresponding reference characters indicate corresponding elements among the view of the drawings. The headings used in the figures should not be interpreted to limit the scope of the claims.

## DETAILED DESCRIPTION

**[0036]** Various embodiments of a drill attachment that may be secured to a drill apparatus so that a user may operate the drill apparatus through the drill attachment while in a substantially upright position are disclosed. In some embodiments, the drill attachment includes an adapter component that allows the drill attachment to be operatively engaged to different types of drill apparatuses regardless of configuration. In some embodiments, the adapter component includes an upper clamp member coupled to a lower clamp member configured to engage a handle of the drill apparatus to permit remote actuation of the drill apparatus trigger through actuation of a trigger actuator of the drill attachment. In some embodiments, the adapter component includes a distal portion having a curved shape configured to engage around the handle of the drill apparatus to also permit remote actuation of the drill apparatus trigger through actuation of a trigger actuator of the drill attachment. Referring to the drawings, embodiments of the drill attachment is illustrated and generally indicated as **100** and **200** in FIGS. 1-28.

**[0037]** As shown in FIG. 1, a first embodiment of the drill attachment, designated **100**, may be adapted to be operatively engaged to a drill apparatus **10** having a body **12** defining a proximal portion **18** forming a handle **14** and a distal portion **20** forming an engagement point **24**. The engagement point **24** formed by the body **12** of the drill apparatus **10** allows the drill apparatus **10** to be engaged to a first portion of the drill attachment **100**. In some embodiments the engagement point **24** defines a threaded hole defined through the body **12** of the drill apparatus **10** which is adapted for use in engaging a removable lateral handle (not shown) used by an individual in directly handling the drill apparatus **10** when not engaged to the drill attachment **100**. In some embodiments, the handle **14** includes a drill trigger **16** that may be actuated by the drill attachment **100** such that the user does not have to directly actuate the drill trigger **16** to operate the drill apparatus **10**. In some embodiments, the handle **14** is configured for engagement with an adapter component **104** for coupling a second portion of the drill attachment **100** to the drill apparatus **10**

regardless of the configuration of the handle **14**. In one embodiment, the drill apparatus **10** may be any type of conventional drill apparatus **10**, such as a hammer drill.

**[0038]** Referring to FIGS. **1-8**, the drill attachment **100** may include a bifurcated frame **102** having an elongated, hollow tubular first shaft **118** and an elongated, hollow tubular second shaft **119**. As shown, the first shaft **118** defines a proximal shaft portion **130** adapted for handling and actuating the drill attachment **100** and a distal shaft portion **131** configured for physically coupling the adapter component **104** to the handle **14** of the drill apparatus **10** when securing the drill attachment **100** to the drill apparatus **10** as shall be described in greater detail below. In one embodiment, the proximal shaft portion **130** of the first shaft **118** may include a grip **122** made of plastic or rubber material adapted for handling by the individual when operating the drill attachment **100**.

**[0039]** As further shown, the second shaft **119** defines a proximal shaft portion **132** that extends from the proximal shaft portion **130** of the first shaft **118** at a set angle relative to the first shaft **118**. In addition, the second shaft **119** defines a distal shaft portion **133** adapted to engage and secure the drill attachment **100** to the engagement point **24** formed along the drill apparatus **10**. In addition, a support shaft **120** may be laterally interposed between the first shaft **118** and second shaft **119** to provide structural support and reinforcement for the bifurcated frame **102**. As noted above, the first shaft **118** and second shaft **119** are adapted to engage the drill attachment **100** to the distal portion **20** and proximal portion **18** of the drill apparatus **10**, respectively.

**[0040]** As shown in FIG. **7**, in some embodiments the first shaft **118** of the drill attachment **100** may include a first base plate **134** configured to engage the adapter component **104** to the handle **14** of the drill apparatus **10** when engaging the drill attachment **100** to the drill apparatus **10**. In particular, the first base plate **134** defines a planar surface **146** forming an aperture (not shown) configured to engage the adapter component **104** to the first shaft **118** of the bifurcated frame **102** using a securing member **136**. In some embodiments, the securing member **136** may include a cap portion **156** and an axial rod portion

**157**. The cap portion **156** of the securing member **136** is configured for manual rotation by the user when coupling the first base plate **134** to the adapter component **104**. The axial rod portion **157** of the securing member **136** defines external threads **158** (FIG. 3) configured to be inserted through the first base plate **134** and the adapter component **104** for coupling the adapter component **104** to the first shaft **118** of the drill attachment **100** as shall be described in greater detail below.

**[0041]** Referring to FIGS. 7-13, in some embodiments the adapter component **104** includes an upper clamp member **110** coupled to a lower clamp member **111** that collectively engage the handle **14** of the drill apparatus **10** proximate the drill trigger **16**. As shown, the upper clamp member **110** defines an angled attachment portion **153** configured to engage an attachment member **112** which secures the adapter component **104** to the first shaft **118** of the drill attachment **100** as shown on FIGS. 7 and 8. The upper clamp member **110** further defines a middle portion **151** formed between the angled attachment portion **153** and a curved portion **152**, which is defined at the free end of the upper clamp member **110**.

**[0042]** As shown in FIG. 13, the attachment member **112** defines a semi-circular slot **140** and an aperture **141** formed through the attachment member **112**. The semi-circular slot **140** of the attachment member **112** is configured to engage the adapter component **104** to the first shaft **118** as shown in FIGS. 7 and 8. When the aperture **141** of the attachment member **112** is aligned with the aperture **143** of the upper clamp member **110** and the aperture (not shown) defined by the first base plate **134** the securing member **136** may be inserted through the aligned apertures to couple the attachment member **112** to the upper clamp member **110** and the first base plate **134** of the drill attachment **100**.

**[0043]** Referring back to FIGS 9-13, in some embodiments the lower clamp member **111** defines an attachment portion **148** configured to be attached to the middle portion **151** of the upper clamp member **110** through a securing member **113**, such as a wing nut, when coupling the lower clamp

member **111** to the upper clamp member **110**. In addition, the lower clamp member **111** defines a first angled portion **149** and a second angled portion **150** that collectively form a channel **121** (FIG. **9**) with the curved portion **152** of the upper clamp member **110** when the upper clamp member **110** is coupled to the lower clamp member **111**. As shown in FIG. **1**, the upper and lower clamp members **110** and **111** of the adapter component **104** are configured to engage securely around the handle **14** of the drill apparatus **10** such that the drill trigger **16** may be actuated by the drill attachment **100** as shall be described in greater detail below. As further shown, the middle portion **151** of the upper clamp member **110** defines an elongated slot **142** that is aligned with the slot **144** of the lower clamp member **111** when coupling the upper clamp member **110** to the lower clamp member **111** with securing member **134**.

**[0044]** As shown in FIGS. **1** and **3**, the second shaft **119** of the drill attachment **100** may include a second base plate **135** defining a planar surface **170** (FIG. **3**) configured to engage the proximal shaft portion **133** of the second shaft **119** to the engagement point **24** formed by the drill apparatus **10**. As noted above, the engagement point **24** defines internal threads configured to engage a securing member **137** having a cap portion **160** and an axial rod portion **161** defining external threads **163** configured to engage the internal threads of the engagement point **24**. The cap portion **160** of the securing member **137** is configured to be manually rotated by the user when coupling the second base plate **135** to engagement point **24** the drill apparatus **10**, while the axial rod portion **157** of the securing member **137** is configured to be inserted through the aperture (not shown) defined through the second base plate **137** and engaged within the engagement point **24** of the drill apparatus **10** such that rotation of the cap portion **160** causes the external threads **163** of the securing member **137** to engage the second base plate **135** of the drill attachment **100** to the engagement point **24** of the drill apparatus **10**.

**[0045]** Referring to FIGS. **1-6**, **15** and **16**, the drill attachment **100** includes an actuating handle **123** secured to the proximal shaft portion **130** of first shaft **118** to provide a means of actuating the drill apparatus **10** using the

pivot action of the actuating handle **123** to actuate the drill trigger **16**. As shown in FIG. **15**, the actuating handle **123** is pivotally engaged along the proximal shaft portion **130** at a first pivot point **164**. A screw **165** engages the actuating handle **123** at first pivot point **164** such that the actuating handle **123** may be pivoted between a position **A** wherein the actuating handle **123** is unbiased and does not actuate the drill trigger **16** and a position **B** (shown in phantom) wherein the individual pulls the actuating handle **123** back toward the grip **122** to actuate the drill trigger **16** and then allowing the actuating handle **14** to be biased back to a resting position **A** in order to terminate operation of the drill apparatus **10**.

**[0046]** As further shown in FIGS. **15** and **16**, the actuating handle **123** is operatively engaged to a trigger actuator **166** through a trigger cable **167** slidably enclosed in a cable sheath **168** that provides a protective covering to the trigger cable **167**. In one embodiment, the trigger cable **167** may be made from a metal wire having one end engaged to the actuating handle **123** and an opposite end operatively engaged to the trigger actuator **166** such that the action of the trigger cable **167** actuates or terminates actuation of the drill trigger **16**. A first stationary arm **170** extends from the first shaft **118** and engages the trigger cable **167** proximate the actuating handle **123**.

**[0047]** In one embodiment, the cable sheath **168** may be disposed within the hollow construction of the bifurcated frame **102**. The cable sheath **168** may enter a first opening **172** (FIG. **15**) defined along the proximal shaft portion **130** of first shaft **118**. The first opening **172** communicates with a second opening **173** (FIG. **16**) defined at the distal shaft portion **131** of the first shaft **118** through a conduit **174** formed along the bifurcated frame **102**. As such, a substantial portion of the cable sheath **168** may be disposed inside the bifurcated frame **102**. In the alternative, a metal rod (not shown) may be substituted for the trigger cable **167** which may be operatively engaged between the actuating handle **123** and the trigger actuator **166** that is disposed outside the bifurcated frame **102** in order to provide a means for actuating the trigger actuator **166** upon operation of the actuator handle **123**.

**[0048]** The trigger actuator **166** includes the stationary arm **170** secured to the distal shaft portion **131** of the first shaft **118** which is adapted to engage the trigger cable **167**. The trigger actuator **166** may further include a rocking arm **169** that pivots about a second pivot point **178** (FIG. **14**) defined along the distal shaft portion **133** of the first shaft **118** between positions **A** and **B** as illustrated in FIG. **16**. In this embodiment, position **A** depicts the trigger actuator **166** in the disengaged position relative to drill trigger **16**, while position **B** depicts the trigger actuator **166** in the engaged position relative to drill trigger **16**. The rocking arm **169** of the drill trigger **16** permits selective operation of the drill apparatus **10** when pivoted by operation of the actuator handle **14** such that the drill trigger **16** is either engaged (position **B**) or disengaged (position **A**).

**[0049]** As shown in FIGS. **14** and **16**, the rocking arm **169** defines a retaining arm **180** that is operatively engaged to the terminal end of the trigger cable **167**, a pivoting arm **181** that pivots about second pivot point **178** when actuated by the actuator handle **14**, and an actuating arm **182** defining a slot (not shown) having an actuating pad **183** that is adapted to engage or disengage the drill trigger **16** when the rocking arm **169** is pivoted by the action of the trigger cable **167**. Referring to FIG. **14**, in one embodiment a bolt and nut arrangement **185** may be used to secure and adjust the actuating pad **183** along the slot of the actuating arm **182**.

**[0050]** In addition, a tightening nut **186** may be operatively engaged to the trigger cable **167** proximate the trigger actuator **166** such that rotation of the tightening nut **186** causes the trigger cable **167** to be lengthened or shortened in order to loosen or tighten the trigger cable **167** relative to the trigger actuator **166**. Another tightening nut **187** may be operatively engaged to the trigger cable **167** proximate the actuator handle **123** in order to also adjust the length of the trigger cable **167** in a similar manner.

**[0051]** The trigger cable **167** may be operatively engaged between the stationary arm **170** and the retaining arm **180** such that actuation of the actuator handle **123** allows the trigger cable **167** to lift the retaining arm **180** by the pulling action of the trigger cable **167** which causes the rocking arm **169** to

pivot. This pivoting action of the rocking arm **169** around the second pivot point **178** causes the actuation arm **182** to move between position **A** and position **B** in order to engage and disengage the drill trigger **16** and operate the drill apparatus **10**. A spring **184** may be provided between the stationary arm **170** and the rocking arm **169** for providing a biasing action such that release of the actuator handle **123** causes the rocking arm **169** to be biased back to position **A** which disengages the actuating pad **183** from the drill trigger **16** and terminates operation of drill apparatus **10**. In one embodiment, the trigger cable **167** may be disposed within the coiled lumen of the spring **184**.

**[0052]** Referring to FIGS. **1-6**, in an embodiment the drill attachment **100** may further include a knee pad **106** which is engaged to the first shaft **118** through a lateral knee pad arm **115**. The lateral knee pad arm **115** may include an adjustable sleeve **116** in operative engagement with a fastening mechanism **138** to adjust the height of the lateral knee pad arm **115** relative to first shaft **118**. In addition, a secondary adjustable sleeve **139** may be provided along the lateral knee pad arm **115** for adjusting the distance of the knee pad **106** relative to the first shaft **118**. The knee pad **106** may provide a soft contact surface for use by the operator to engage with the user's knee in order to apply a force against the drill apparatus **10** when abutting the drill apparatus **10** against a concrete slab or other drill apparatus surface when the user is in a substantially upright position.

**[0053]** As noted above, the adapter component **104** is used to couple the drill attachment **100** to various types of drill apparatuses **10**, especially those drill apparatuses **10** that lack a second engagement point configured to secure the first shaft **118** to the drill apparatus **10**. Once the drill attachment **100** is secured to the drill apparatus **10** in the manner described above, the individual may operate the drill attachment **100** by gripping the actuator handle **123** and grip **122** with one hand and the second shaft **119** with the other hand. As noted above, the individual may engage the knee pad **106** with the individual's knee in order to apply a lateral force to the drill apparatus **10** through the drill attachment **100**. The individual may then squeeze the actuator handle **123** which pivots the

rocking arm **169** from position **A** to position **B** and causes the drill trigger **16** to be engaged by the actuating arm **182** until the user releases the actuator handle **123** which is biased back to position **A**.

**[0054]** In one embodiment, the first shaft **118**, second shaft **119**, support shaft **120** may be welded together, although other methods of attachment are contemplated, such as using a bolt and screw combination, or other mechanical arrangement to assemble and secure the bifurcated assembly **102**.

**[0055]** Referring to FIGS. **17-27**, a second embodiment of the drill attachment, designated **200**, may be adapted to be operatively engaged to the drill apparatus **10** having body **12** defining proximal portion **18** forming a handle **14** and a distal portion **20** defining an engagement point **24** for engaging for drill apparatus **10** to the drill attachment **200**. Similarly, the handle **14** also includes a trigger **16** that is remotely actuated by the drill attachment **200** such that the user does not have to directly actuate the drill trigger **16** to operate the drill apparatus **10**. In some embodiments the engagement point **24** defines a threaded hole defined through the body **12** of the drill apparatus **10** which is adapted for use in engaging a removable lateral handle (not shown) used by an individual in directly handling the drill apparatus **10** when not engaged to the drill attachment **100**. In some embodiments, the handle **14** includes a drill trigger **16** that may be actuated by the drill attachment **200** such that the user does not have to directly actuate the drill trigger **16** to operate the drill apparatus **10**. In some embodiments, the handle **14** is configured for engagement with an adapter component **204** for operatively coupling the drill attachment **200** to the drill apparatus **10** regardless of the configuration of the handle **14**.

**[0056]** Referring to FIGS. **17-22**, in some embodiments the drill attachment **200** may include a bifurcated frame **202** having an elongated, hollow tubular first shaft **218** and an elongated, hollow tubular second shaft **219**. As shown, the first shaft **218** defines a proximal shaft portion **230** adapted for handling and actuating the drill attachment **200** and a distal shaft portion **233** configured for physically coupling the adapter component **204** to the handle **14** of

the drill apparatus **10** when securing the drill attachment **200** to the drill apparatus **10** as shall be described in greater detail below. In one embodiment, the proximal shaft portion **230** of the first shaft **218** may include a grip **222** made of plastic or rubber material adapted for handling by the individual when operating the drill attachment **200**.

**[0057]** As further shown, the second shaft **219** defines a proximal shaft portion **232** that extends from the proximal shaft portion **230** of the first shaft **218** at a set angle relative to the first shaft **218**. In addition, the second shaft **219** defines a distal shaft portion **231** adapted to engage and secure the drill attachment **200** to the engagement point **24** formed along the drill apparatus **10**. In addition, a support shaft **220** (FIG. **18**) may be laterally interposed between the first shaft **218** and second shaft **219** to provide structural support and reinforcement for the bifurcated frame **202**. As noted above, the first shaft **218** and second shaft **219** are adapted to engage the drill attachment **200** to the distal portion **20** and proximal portion **18** of the drill apparatus **10**, respectively.

**[0058]** In some embodiments, the second shaft **219** of the drill attachment **200** may include a base plate **235** (FIG. **19**) defining a planar surface **270** (FIG. **20**) configured to engage the proximal shaft portion **231** of the second shaft **219** to the engagement point **24** formed by the drill apparatus **10**. As shown in FIG. **20**, the engagement point **24** defines internal threads configured to engage a securing member **237** having a cap portion **260** and an axial rod portion **261** defining external threads **263** configured to engage the internal threads of the engagement point **24**. The cap portion **260** of the securing member **237** is configured to be manually rotated by the user when coupling the base plate **235** to engagement point **24** the drill apparatus **10**, while the axial rod portion **261** of the securing member **237** is configured to be inserted through the aperture (not shown) defined through the base plate **235** and engaged within the engagement point **24** of the drill apparatus **10** such that rotation of the cap portion **260** causes the external threads **263** of the securing member **237** to engage the base plate **235** of the drill attachment **200** to the engagement point **24** of the drill apparatus **10**.

**[0059]** Referring to FIGS. **18-22**, similar to drill attachment **100**, the drill attachment **200** includes an actuating handle **223** secured to the proximal shaft portion **230** of first shaft **218** to provide a means of actuating the drill apparatus **10** using the pivot action of the actuating handle **223** to actuate the drill trigger **16** as described above in relation to drill attachment **100**. As shown in FIG. **19**, the actuating handle **223** is pivotally engaged along the proximal shaft portion **230** such that the actuating handle **223** may be pivoted between a resting position when the actuating handle **223** is unbiased and not actuating the drill trigger **16** and a biased position wherein the individual pulls the actuating handle **223** back toward the grip **222** to actuate the drill trigger **16** and then allowing the actuating handle **14** to be biased back to a resting position in order to terminate operation of the drill apparatus **10**.

**[0060]** As further shown in FIG. **19**, the actuating handle **223** is operatively engaged to a trigger actuator **266** through a trigger cable slidably enclosed in a cable sheath that provides a protective covering to the trigger cable. In one embodiment, the trigger cable may be made from a metal wire having one end engaged to the actuating handle **223** and an opposite end operatively engaged to the trigger actuator **266** such that the action of the trigger cable actuates or terminates actuation of the drill trigger **16**. A first stationary arm **270** extends from the first shaft **218** and engages the trigger cable proximate the actuating handle **223**.

**[0061]** As shown in FIG. **19**, the trigger actuator **266** includes the stationary arm **270** secured to the distal shaft portion **233** of the first shaft **218** which is adapted to engage the trigger cable **267**. The trigger actuator **266** may further include a rocking arm **269** that pivots about a second pivot point **278** defined along the distal shaft portion **233** of the first shaft **218** between the resting position (shown in solid line) and a biased position (shown in phantom line). In this embodiment, the resting position depicts the trigger actuator **266** in the disengaged position relative to drill trigger **16**, while biased position depicts the trigger actuator **266** in the engaged position relative to drill trigger **16**. The rocking arm **269** of the drill trigger **16** permits selective operation of the drill

apparatus **10** when pivoted by operation of the actuator handle **14** such that the drill trigger **16** is either engaged or disengaged.

**[0062]** As shown in FIGS. **19** and **20**, the rocking arm defines a retaining arm **280** that is operatively engaged to the terminal end of the trigger cable **267**, a pivoting arm **281** that pivots about second pivot point **278** when actuated by the actuator handle **14**, and an actuating arm **282** defining a slot (not shown) having an actuating pad that is adapted to engage or disengage the drill trigger **16** when the rocking arm is pivoted by the action of the trigger cable.

**[0063]** As shown in FIGS. **17-22**, in some embodiments the first shaft **218** of the drill attachment **200** may include a base plate **234** configured to engage the adapter component **204** to the handle **14** of the drill apparatus **10** when engaging the drill attachment **200** to the drill apparatus **10**. In particular, as shown in FIG. **18** the base plate **234** defines a planar surface **246** forming an aperture (not shown) configured to engage the adapter component **204** to the first shaft **218** of the bifurcated frame **202** using a securing member **236**. As shown, the adapter component **204** is configured to permit universal engagement of the drill attachment **200** to any type of drill apparatus **10**, while allowing the remote actuation of the drill apparatus **10** by the operation of the drill attachment **200** as the user maintains a substantially upright position.

**[0064]** Referring to FIGS. **23-27**, in some embodiments the adapter component **204** defines an upper surface **250** and an opposite lower surface **252** that collectively define a proximal portion **280**, a middle portion **282** and a distal portion **284** of the adapter component **204**. As shown in FIGS. **26** and **27**, the proximal portion **280** defines an open slot **290** configured to engage and orient the distal portion **231** of the first shaft **218** in similar fashion as illustrated in FIG. **7**.

**[0065]** Referring to FIG. **23**, in some embodiments the distal portion **284** of the adapter component **204** has a curved shape configured to engage around the handle **14** of the drill apparatus **10** in a manner that allows the first shaft **218** of the drill attachment **200** to be adequately secured to the drill apparatus **10**. In this fashion, the adapter component **204** allows the drill

attachment **200** to be operatively engaged to any type of conventional drill apparatus **10**.

**[0066]** As shown in FIGS. **26** and **27**, the proximal portion **280** of the adapter component **204** defines open slot **290** configured to engage the adapter component **204** to the first shaft **218** of the drill attachment **200**. In addition, the proximal portion **280** of the adapter component **204** defines an aperture **241** proximate the open slot **290** which is configured to receive securing member **236** that secures the adapter component **204** to the base plate **234** of the drill attachment **200**.

**[0067]** In some embodiments, the middle portion **282** of the adapter component **204** may be oriented at a 45 degree angle relative to the proximal portion **280** and the distal portion **284**. In some embodiments, the middle portion **282** may be angled in a range between 35 degrees to 55 degrees relative to the proximal portion **280** and distal portion **284**.

**[0068]** Referring to FIG. **28**, a third embodiment of the drill apparatus, designated **300**, is shown in which the adapter component **304**, similar in construction to adapter component **204**, is made integral with the shaft of the drill attachment **300** rather than being coupled and secured to the drill attachment **300** as in previous embodiment described herein.

**[0069]** In another embodiment, the drill attachments **100**, **200** and **300** may be operatively engaged with a cordless drill or a corded drill. In addition, the drill attachments **100**, **200** and **300** may be operatively engaged to the aforementioned types of drills in order to auger holes in wood, masonry, or concrete either at grade or overhead levels.

**[0070]** It should be understood from the foregoing that, while particular embodiments have been illustrated and described, various modifications can be made thereto without departing from the spirit and scope of the invention as will be apparent to those skilled in the art. Such changes and modifications are within the scope and teachings of this invention as defined in the claims appended hereto.

## CLAIMS

What is claimed is:

1. A drill attachment configured to be coupled to a drill apparatus, the drill apparatus having a drill handle with a trigger for actuating the drill apparatus, the drill attachment comprising:
  - a bifurcated frame defining a first shaft and a second shaft, the first shaft defining a proximal shaft portion and distal shaft portion with a base plate defined along a terminal end of the distal shaft portion,
  - a handle pivotally engaged to the proximal shaft portion of the first shaft, the handle being operatively engaged with a trigger cable;
  - an adapter component engaged to the distal shaft portion of the first shaft, the adapter component comprising:
    - an upper clamp member defining an attachment member; and
    - a lower clamp member coupled to the upper clamp member, the upper clamp member and the lower clamp member collectively defining a channel, the upper clamp member and the lower clamp member being engaged to the handle of the drill apparatus such that the handle of the drill apparatus is disposed within the channel formed by the adapter component,
  - wherein the attachment member is secured to the base plate of the first shaft; and
  - a trigger actuator coupled to the trigger cable at the distal shaft portion of the first shaft, the trigger actuator having a rocking arm that pivots on the first shaft and is coupled to the trigger cable, and a lateral knee pad arm engaged to said first shaft such that the first shaft of the bifurcated frame is perpendicular to a longitudinal axis of the drill apparatus engaged to the drill attachment and the lateral knee pad arm is parallel to the longitudinal axis of the drill apparatus.
2. The drill attachment according to claim 1, wherein the attachment member of the adapter component further comprises: a semi-circular slot defined proximate to the distal shaft portion of the first shaft.

3. The drill attachment according to claim 1, wherein the attachment member is oriented at a perpendicular angle relative to the upper clamp member.
4. The drill attachment according to claim 1, wherein the upper clamp member defines an angled attachment portion coupled to the attachment member, a middle portion in communication with the angled attachment portion, and a curved portion formed adjacent the middle portion and opposite the angled attachment portion, wherein the curved portion defines a curved configuration.
5. The drill attachment according to claim 4, wherein the lower clamp member defines an attachment portion coupled to the upper clamp member, a first angled portion in communication with the attachment portion, and a second angled portion formed adjacent the first angled portion and opposite the attachment portion.
6. The drill attachment according to claim 1, wherein the upper clamp member defines a first slot and the lower clamp member defines a second slot that is aligned with the first slot when the upper clamp member is engaged to the lower clamp member, wherein the aligned first and second slots are configured to receive a securing member.
7. The drill attachment according to claim 1, wherein the base plate defines a planar surface engaged with the attachment member.
8. A drill attachment comprising:
  - a bifurcated frame defining a first shaft and a second shaft, the first shaft defining a proximal shaft portion and a distal shaft portion and the second shaft defining a distal shaft portion, and a handle pivotally engaged to the proximal shaft portion; and
  - an adapter component engaged to the distal shaft portion of the first shaft, the adapter component comprising:
    - an upper clamp member including an attachment member coupled to the distal shaft portion of the first shaft, a free end, and an angled attachment portion defined between the free end and the attachment member; and

a lower clamp member coupled to the upper clamp member, the upper clamp member and the lower clamp member collectively defining a channel, the upper clamp member and the lower clamp member configured for engagement with a handle of a drill apparatus such that the handle of the drill apparatus is disposed within the channel formed by the adapter component,

wherein the attachment member further comprises a semi-circular slot configured to be engaged to the distal shaft portion of the first shaft.

9. The drill attachment according to claim 8, wherein the angled attachment portion is oriented at a perpendicular angle relative to the attachment member of the upper clamp member.
10. The drill attachment according to claim 8, wherein the upper clamp member defines a middle portion in communication with the angled attachment portion, and a curved portion formed adjacent the middle portion and opposite the angled attachment portion, wherein the curved portion defines a curved configuration.
11. A drill attachment comprising:
  - a bifurcated frame defining a first shaft and a second shaft, the first shaft defining a proximal shaft portion and a distal shaft portion and the second shaft defining a distal shaft portion, and a handle pivotally engaged to the proximal shaft portion; and
  - an adapter component engaged to the distal shaft portion of the first shaft, the adapter component comprising:
    - an upper clamp member including an attachment member coupled to the distal shaft portion of the first shaft, a free end, and an angled attachment portion defined between the free end and the attachment member; and
    - a lower clamp member coupled to the upper clamp member, the upper clamp member and the lower clamp member collectively defining a channel, the upper clamp member and the lower clamp member configured for engagement with a handle of a drill apparatus such that the handle of the drill apparatus is disposed within the channel formed by the adapter component,

wherein the upper clamp member defines a first slot and the lower clamp member defines a second slot that is aligned with the first slot when the upper clamp member is engaged to the lower clamp member, wherein the aligned first and second slots are configured to receive a securing member.

12. A method of making a drill apparatus comprising:

providing a drill apparatus having a drill trigger and a body defining a proximal portion and a distal portion, the distal portion defining an engagement point and the proximal portion defining a handle;

providing a drill attachment having a bifurcated frame defining a first shaft and a second shaft, the first shaft defining a proximal shaft portion and distal shaft portion, a handle pivotally engaged to the proximal shaft portion of the first shaft, the handle being coupled to a trigger cable, and a trigger actuator coupled to the trigger cable at the distal shaft portion of the first shaft, the trigger actuator having a rocking arm that pivots on the first shaft and is coupled to the trigger cable, wherein the rocking arm includes a retaining arm, wherein the trigger actuator further includes a stationary arm secured to the distal shaft portion of said first shaft, the stationary arm being coupled to the trigger cable, the drill attachment further including a spring including a first end and a second end, the first end coupled to the stationary arm and the second end of the spring being coupled to the retaining arm of the rocking arm, the spring applying a biasing force from the spring to the rocking arm; and

providing an adaptor component including an upper clamp member and a lower clamp member, the upper clamp member including an attachment member; and

coupling the adaptor component with the drill attachment and the drill apparatus, including:

securing the attachment member of the adaptor component to the distal shaft portion of the first shaft of the bifurcated frame of the drill attachment, and

engaging one portion of the upper clamp member to the handle of the drill apparatus.

13. The method according to claim 12, further comprising: attaching an attachment member of the adaptor component defining a semi-circular slot to the first shaft.

14. The method according to claim 12, wherein the upper clamp member defines a first slot and the lower clamp member defines a second slot, and wherein engaging the upper clamp member to the lower clamp member further comprises aligning the first slot with the second slot and then inserting a securing member through the aligned first and second slots to couple the upper clamp member and the lower clamp member.

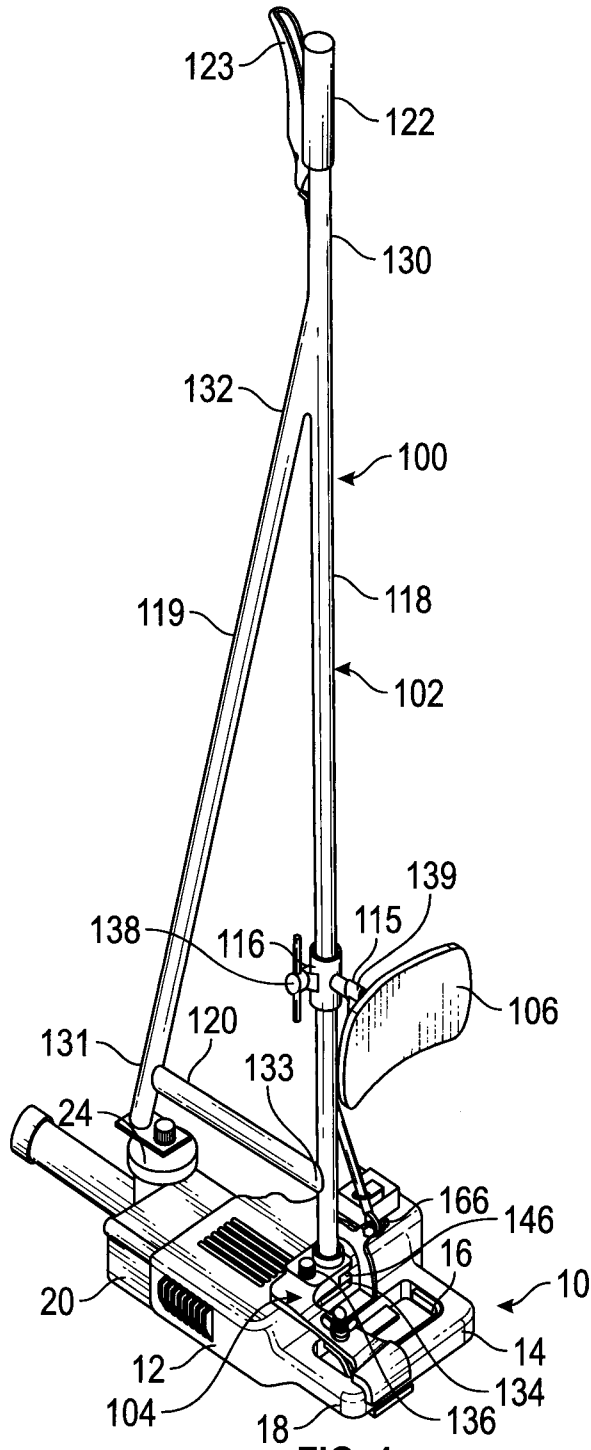

FIG. 1

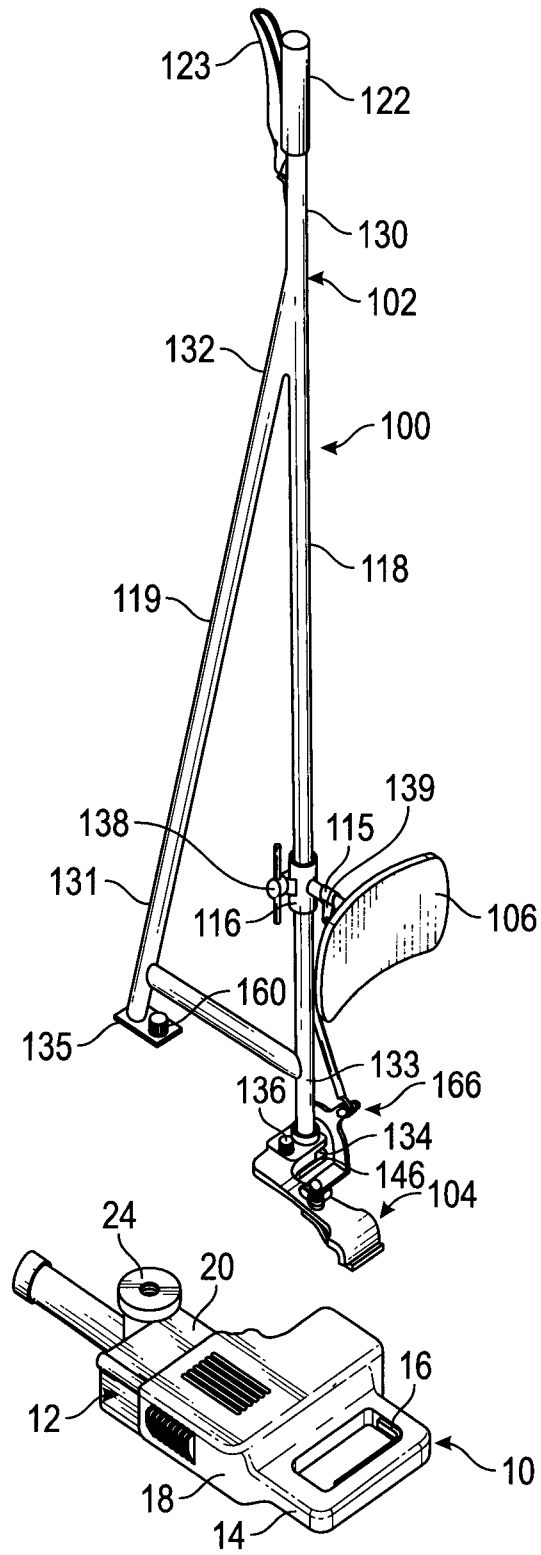

FIG. 2

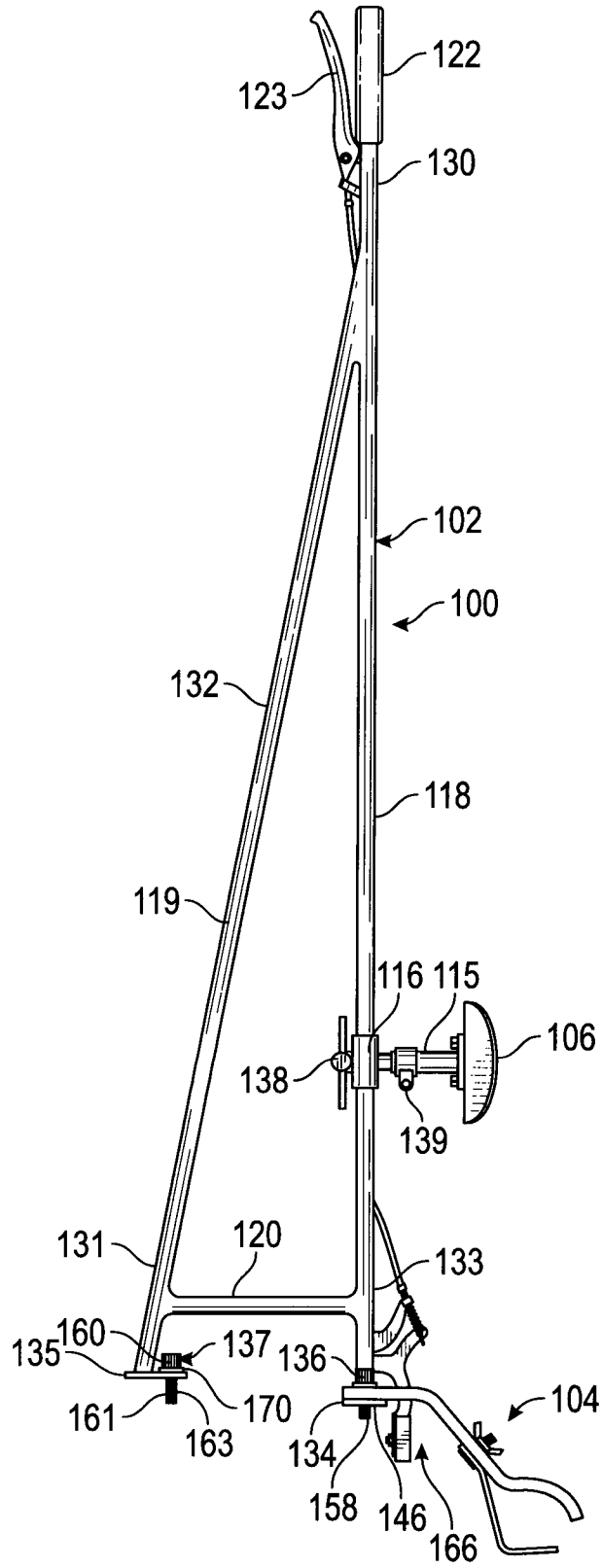

FIG. 3

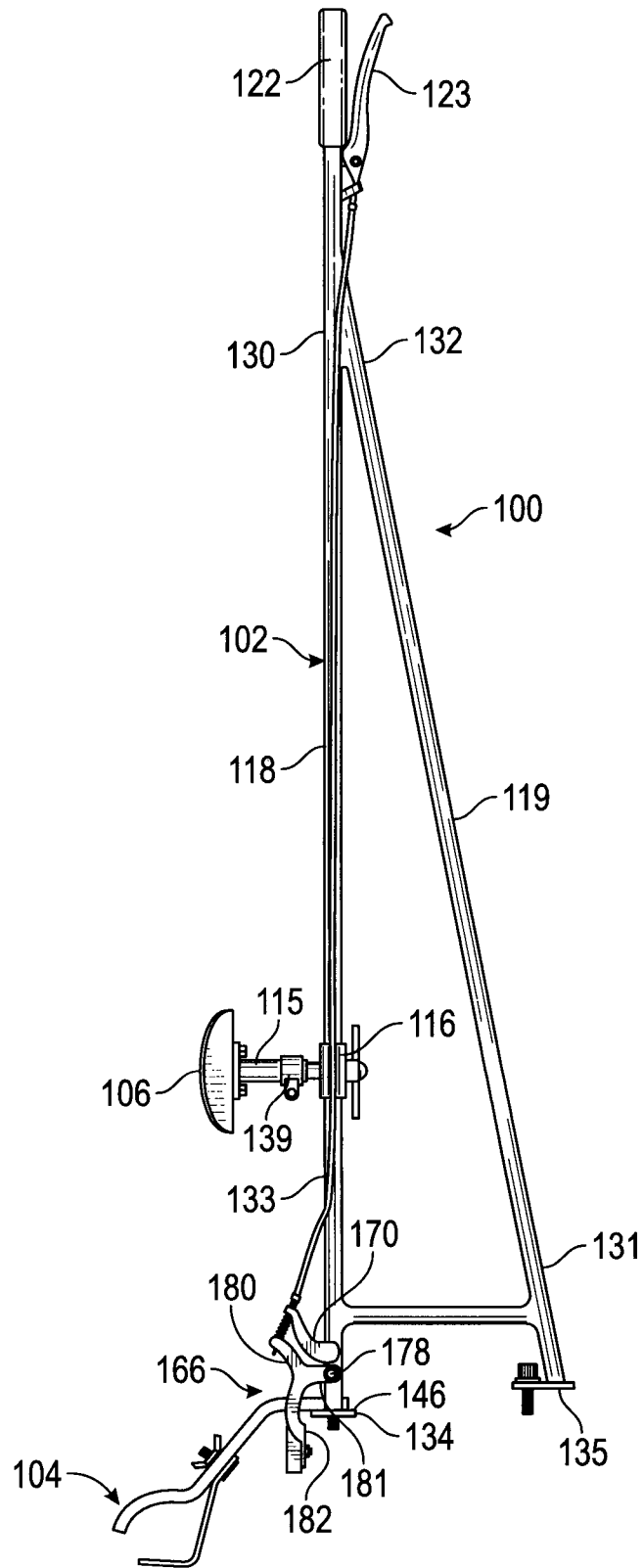

FIG. 4

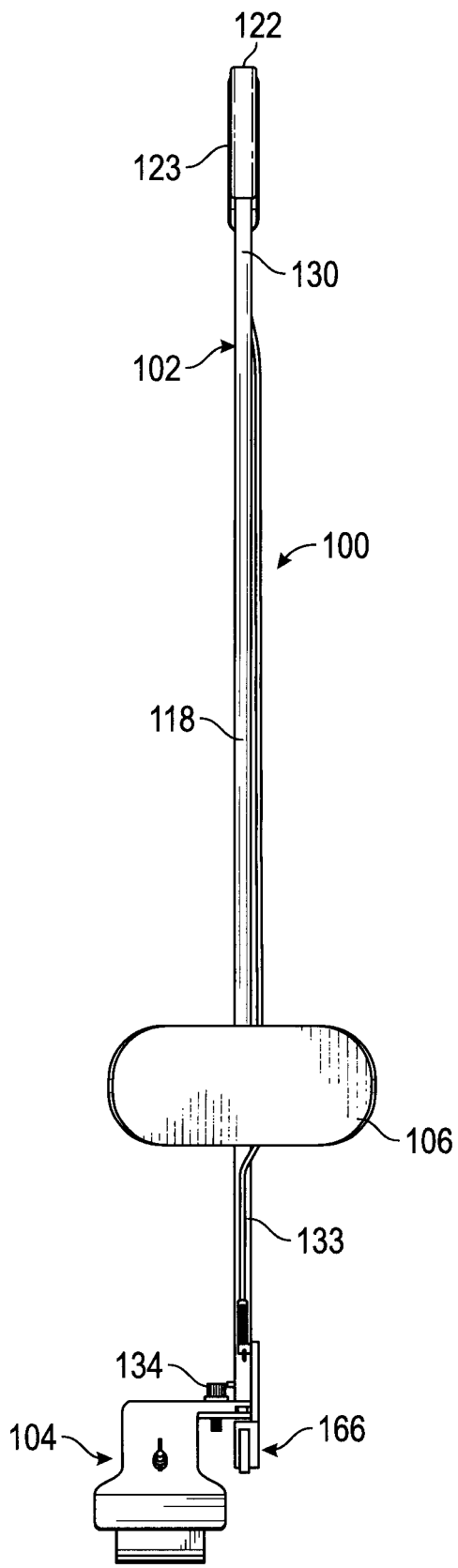

FIG. 5

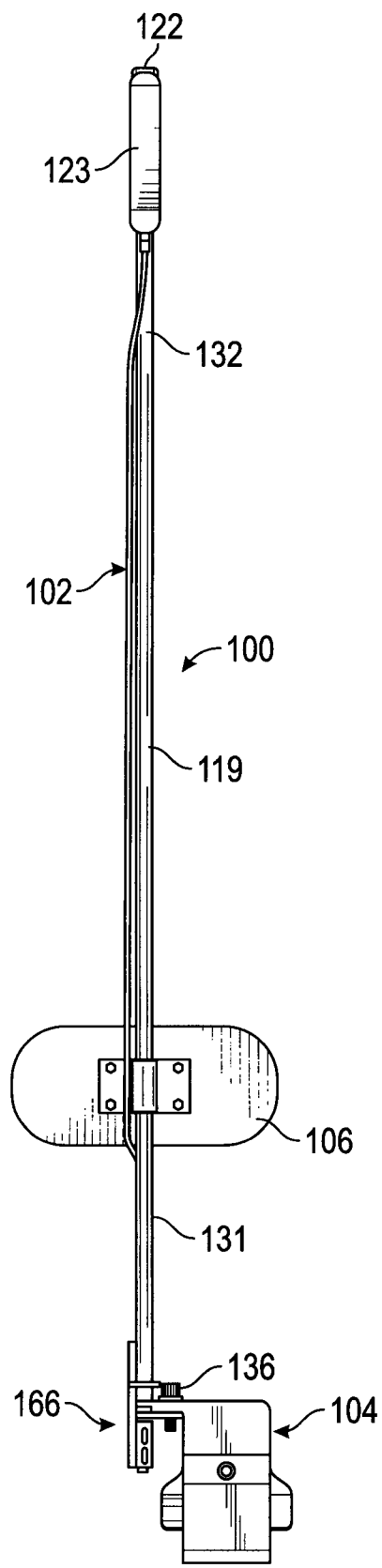

FIG. 6

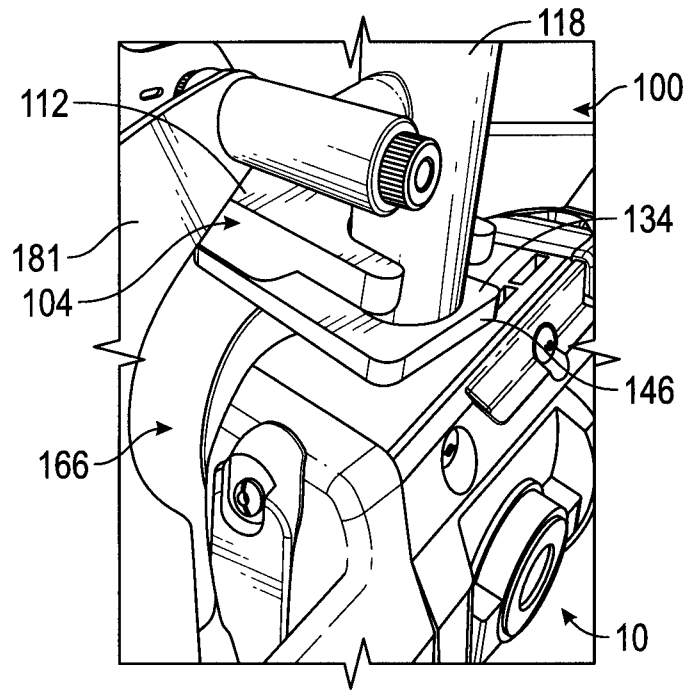

FIG. 7

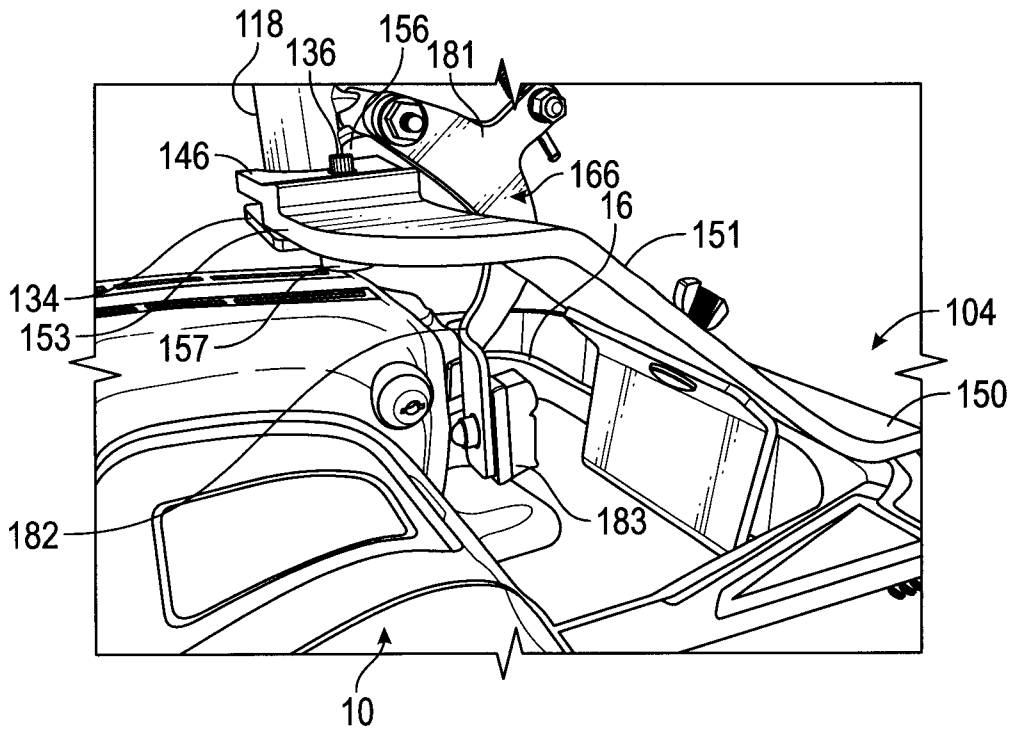

FIG. 8

7/19

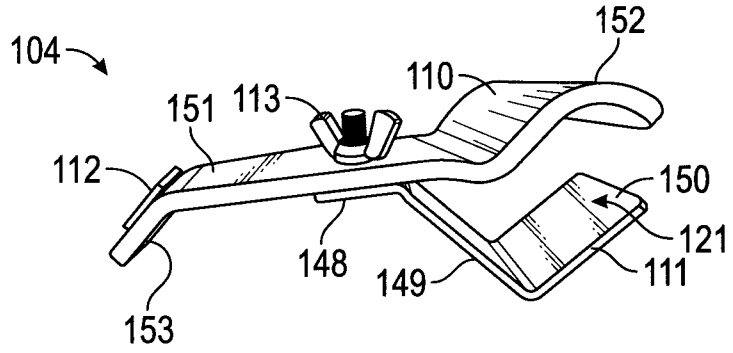

FIG. 9

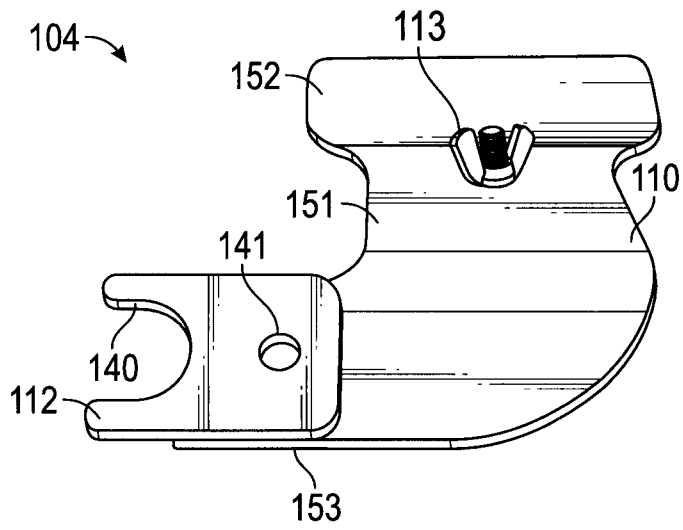

FIG. 10

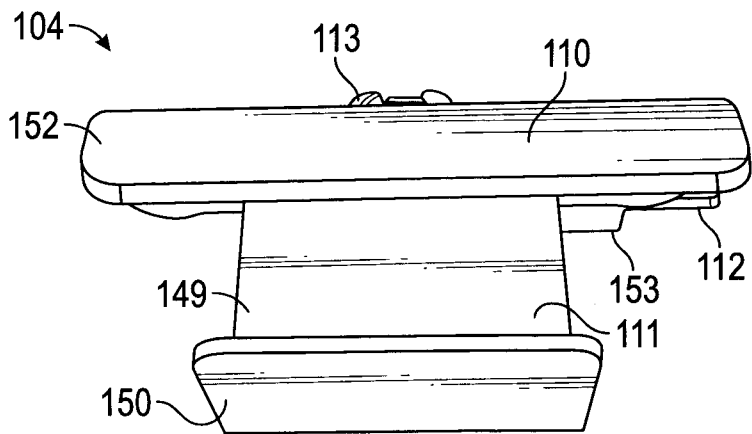

FIG. 11

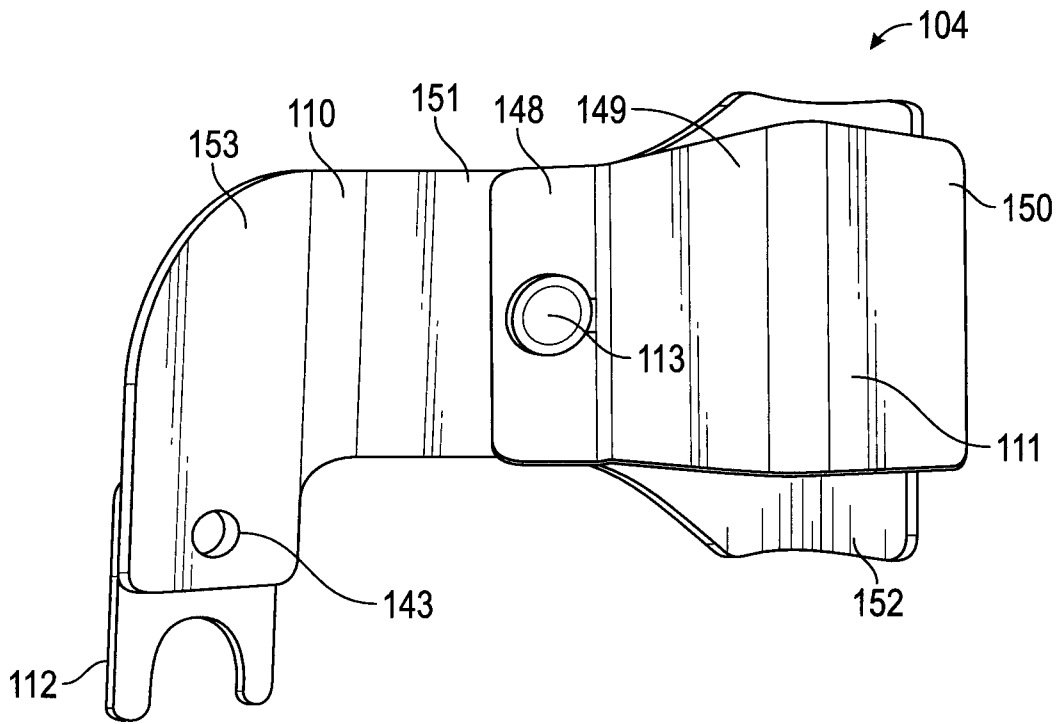

FIG. 12

9/19

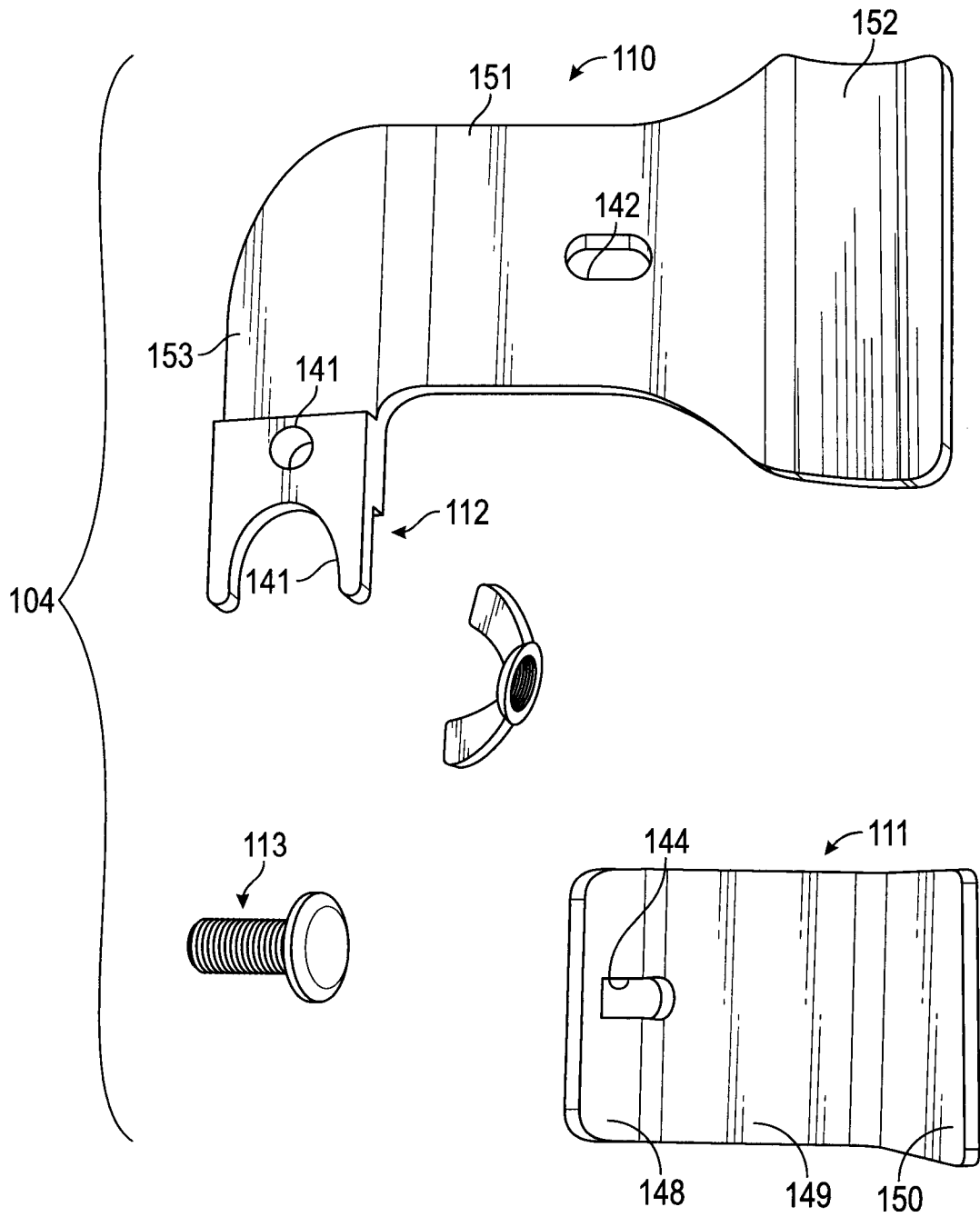

FIG. 13

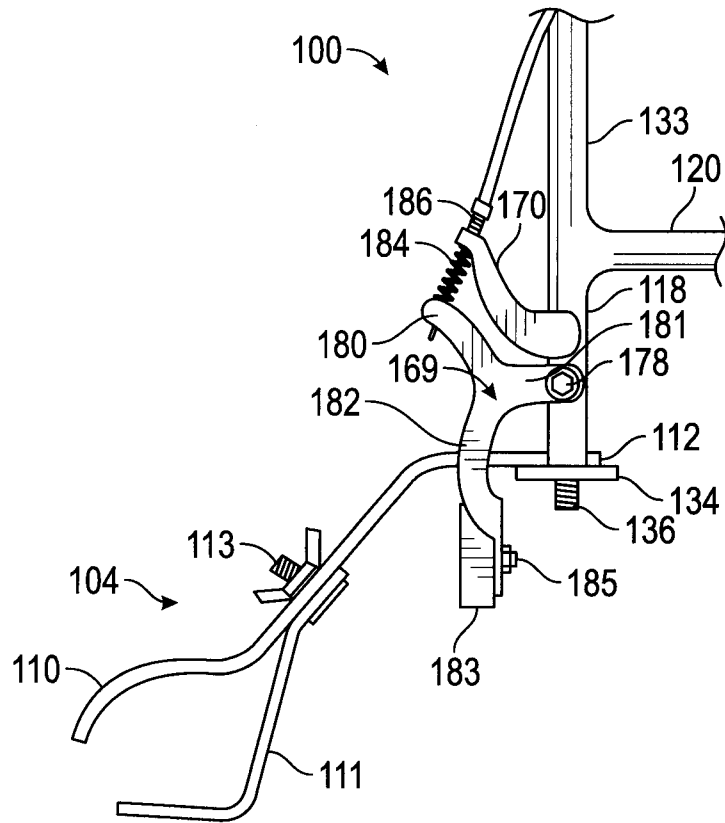

FIG. 14



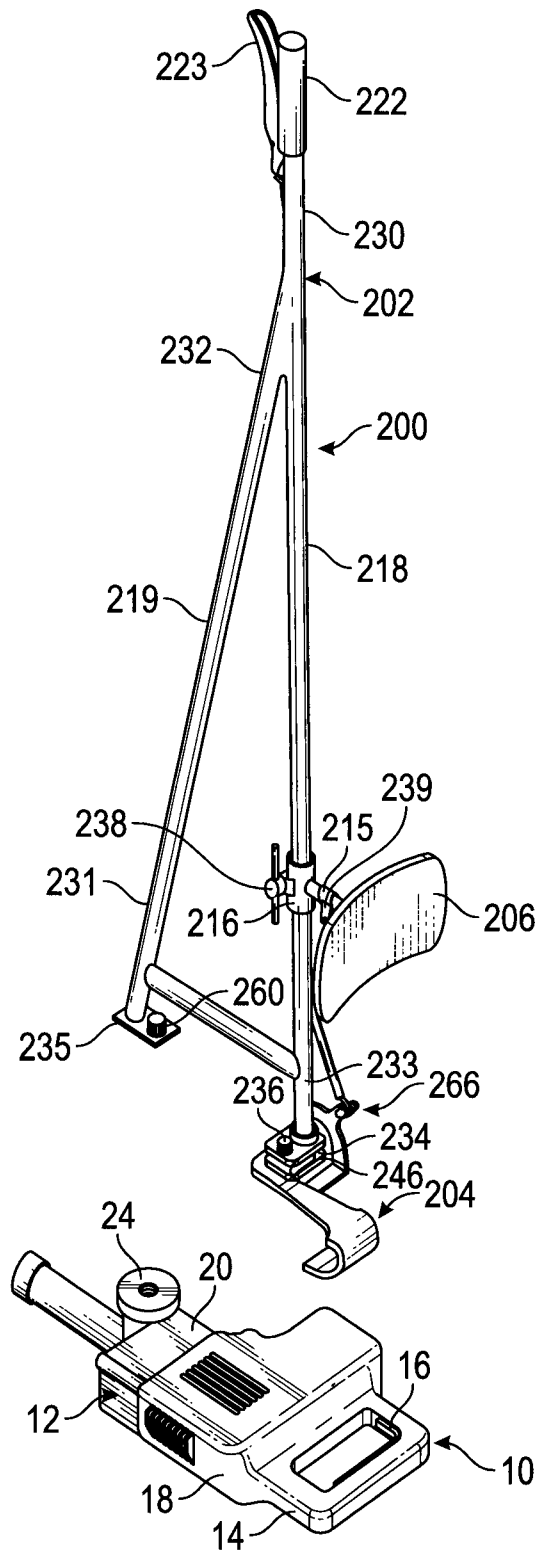

FIG. 17



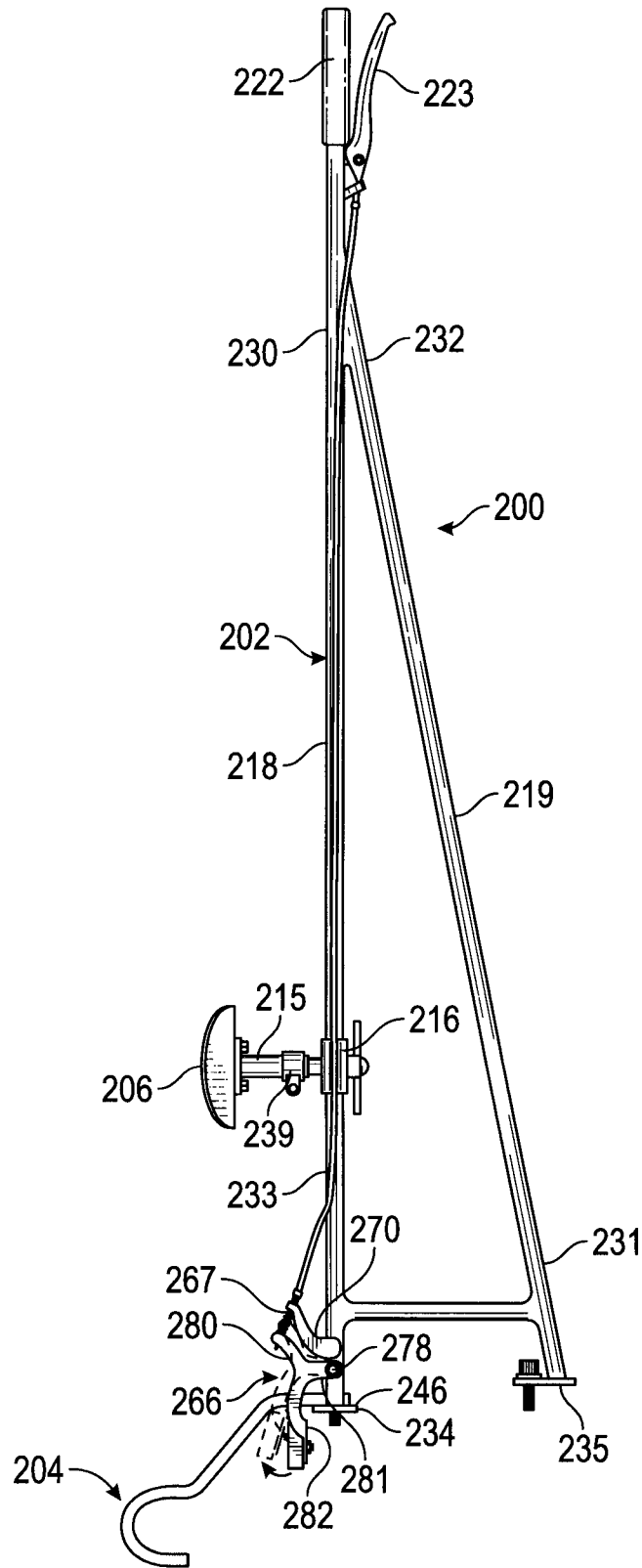

FIG. 19

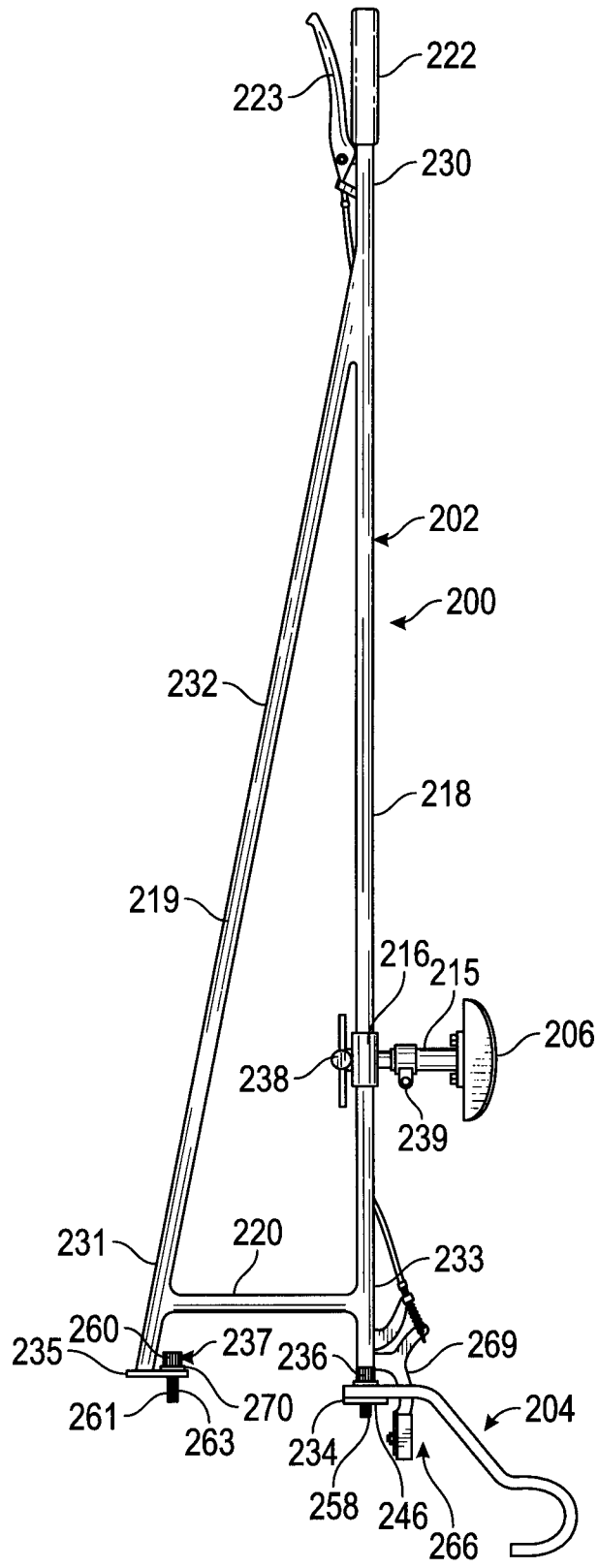

FIG. 20

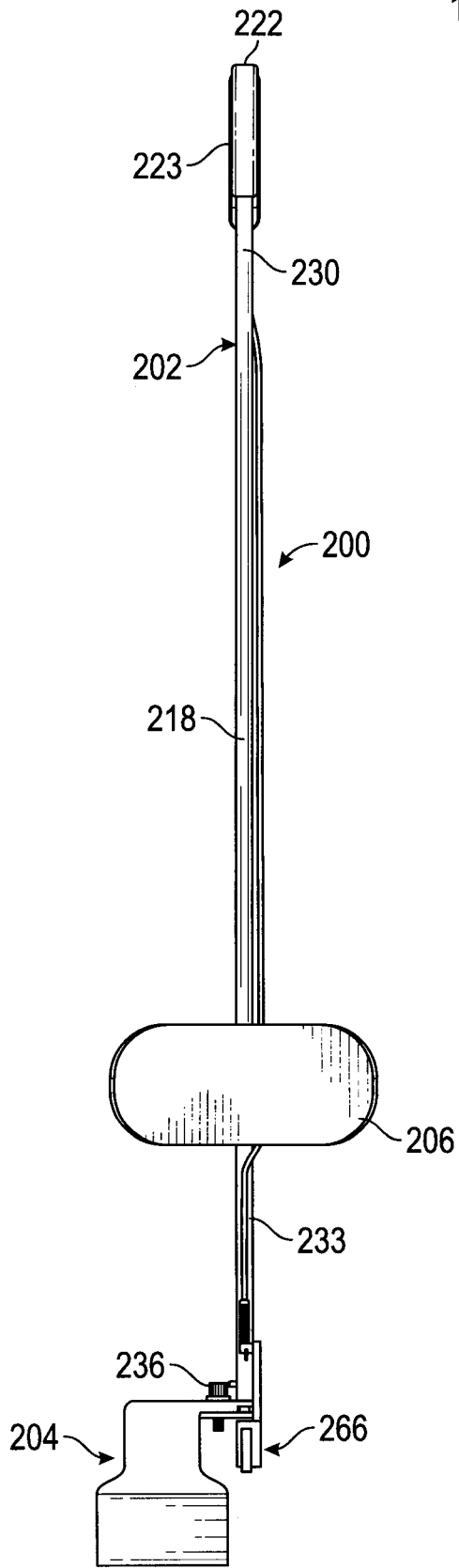

FIG. 21

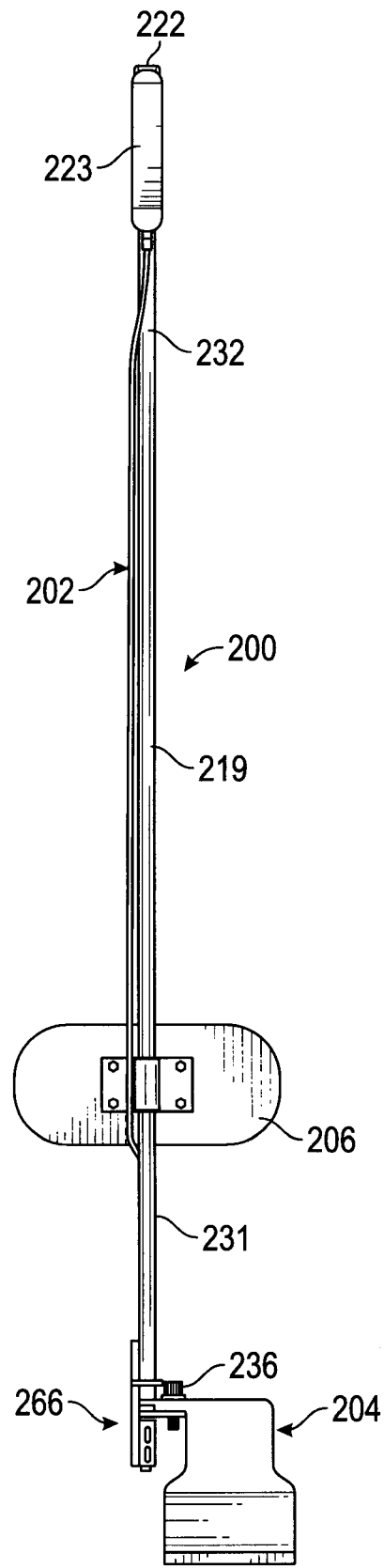

FIG. 22

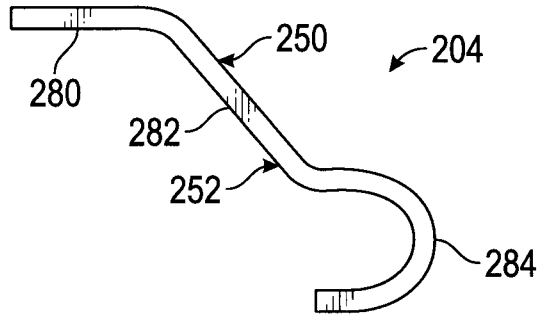

FIG. 23

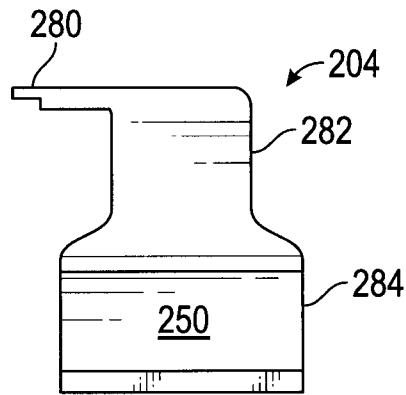

FIG. 24

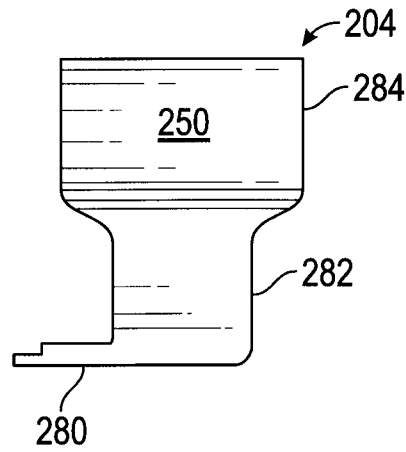

FIG. 25

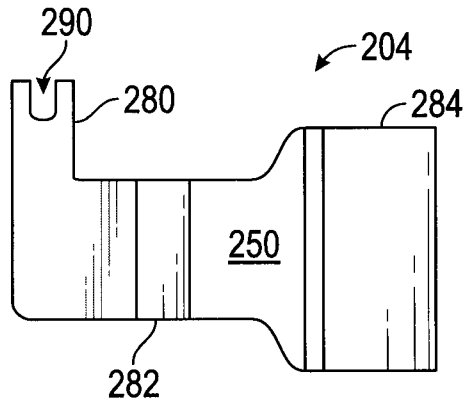

FIG. 26

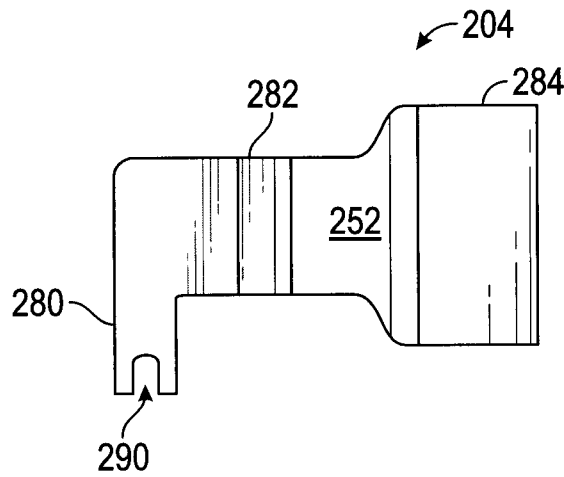

FIG. 27

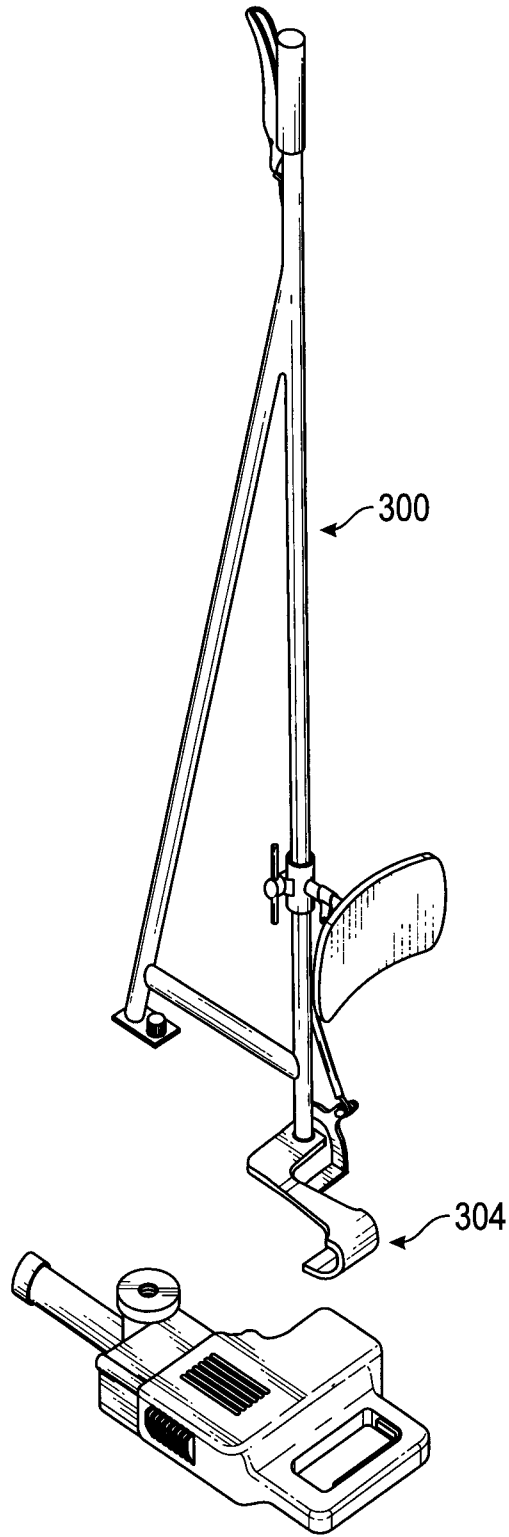

FIG. 28

