

H. W. HAMMERSMITH.
Rail-Joint.

No. 199,437.

Patented Jan. 22, 1878.

Fig. 1.

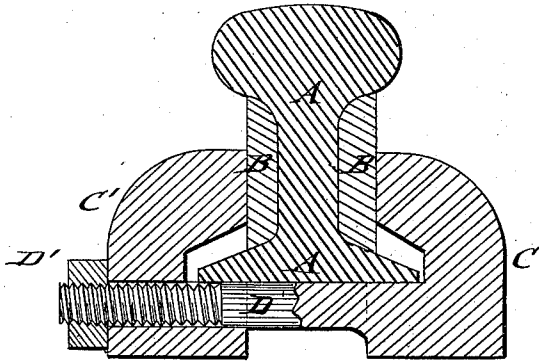
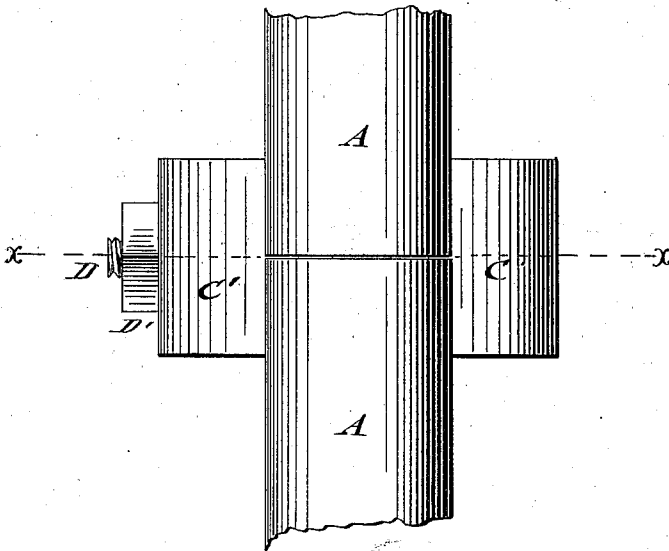

Fig. 2.



WITNESSES:

Henry W. Miller
J. N. Scarborough.

INVENTOR:

H. W. Hammersmith
BY *Munroe*

ATTORNEYS.

UNITED STATES PATENT OFFICE.

HENRY W. HAMMERSMITH, OF SOUTH BEND, OHIO.

IMPROVEMENT IN RAIL-JOINTS.

Specification forming part of Letters Patent No. **199,437**, dated January 22, 1878; application filed November 19, 1877.

To all whom it may concern:

Be it known that I, HENRY W. HAMMERSMITH, of South Bend, in the county of Hamilton and State of Ohio, have invented a new and Improved Rail-Joint, of which the following is a specification:

In the accompanying drawings, forming part of this specification, Figure 1 represents a vertical transverse section on line *x x*, Fig. 2, of my improved rail-joint; and Fig. 2, a top view of the same.

Similar letters of reference indicate corresponding parts.

This invention is intended to furnish an improved vise for connecting broken rails; and it consists of a jaw bearing on the fish-plate at one side of the joint of the rails, and extending in the shape of a bolt below the base to a second jaw, which is secured by a screw-nut on the end of the bolt, so as to bear tightly on the opposite fish-plate.

Referring to the drawings, A represents the rails; B, the fish-plates, that extend at both sides over the joint of the rails; and C C', the clamping-jaws or cheek-pieces, of which one bears on the fish-plates at one side of the rails, and extends by a screw-bolt, D, below the base of the rails to the opposite jaw C'. The bolt D passes through a hole of jaw C', and causes the same to bear on the opposite fish-plate, it being rigidly retained in position by means of a screw-nut, D', that presses the movable jaw C' tightly on the fish-plate, so that the rail ends are firmly retained between the fish-plates. The screw-nut is turned by a wrench, and thereby the required degree of rigidity for the connection of the plates obtained.

The construction of clamp or vise above described is particularly adapted for connecting broken rail-sections, because it can be applied to the rails without moving the latter longitudinally.

A sliding clamp embracing the ordinary fish-bars and the foot of the rail has been used as a joint for rail-sections; and it is also not new to construct a rail-chair of two parts, which are clamped to the base of the rail by means of a screw-stem formed on one of said sections and passing through the other section.

I am not aware of the existence of a rail-joint which is constructed of two sections, adapted to embrace fish or connecting plates, and secured by means of a screw-stem and nut, as in my invention.

While my joint is particularly designed for repairing broken rails, it may also be used for connecting new rails.

It will be understood that even if the rail is broken into small pieces, they can be taken out and properly arranged in relation to the fish-plates when the clamp or vise is applied to retain the parts in position.

My rail-vise does not require a bottom support, and it can therefore be used for repairing rails broken at a point between the cross-ties.

Having thus described my invention, I claim as new and desire to secure by Letters Patent—

The jaw C, having a bottom screw-threaded stem, D, and the jaw C', provided with an apertured base, and the clamping-nut D', in combination with the fish-bars B B and rail-sections A, the jaws embracing the fish-bars and clamping the rail-sections, as and for the purpose set forth.

HENRY W. HAMMERSMITH.

Witnesses:

RICHARD PAULL,
JAMES A. PAULL.