



US 20160153666A1

(19) **United States**
(12) **Patent Application Publication**
Tcaciuc

(10) **Pub. No.: US 2016/0153666 A1**
(43) **Pub. Date: Jun. 2, 2016**

(54) **COOLING AND EXHAUST SYSTEM FOR A COOKING OVEN**

(52) **U.S. Cl.**
CPC *F24C 15/2042* (2013.01); *F24C 15/006* (2013.01)

(71) Applicant: **Electrolux Appliances Aktiebolag**,
Stockholm (SE)

(72) Inventor: **Sorin Tcaciuc**, Satu Mare (RO)

(57) **ABSTRACT**

(21) Appl. No.: **14/905,684**

(22) PCT Filed: **Sep. 2, 2014**

(86) PCT No.: **PCT/EP2014/068544**

§ 371 (c)(1),

(2) Date: **Jan. 15, 2016**

The present invention relates to a cooling and exhaust system (10), in particular for a cooking oven, comprising a fan shroud (12) and a discharging channel (14). An impeller (16) is arranged inside the fan shroud (12), so that the fan shroud (12) and the impeller (16) form a cross-flow fan. The discharging channel (14) is attached at the fan shroud (12) and arranged at the circumferential side of the impeller (16). The discharging channel (14) includes an open end arranged opposite to the fan shroud (12). The discharging channel (14) extends along a horizontal direction. A first inlet (20) is arranged in an upper portion of the fan shroud (12), while a second inlet (22) is arranged in a lower portion of the fan shroud (12). The first inlet (20) and the second inlet (22) are arranged at or close to opposite circumferential sides of the impeller (16). An outlet (24) is arranged at the open end of the discharging channel (14). Further, the present invention relates to a cooking oven with a cooling and exhaust system (10).

(30) **Foreign Application Priority Data**

Sep. 10, 2013 (EP) 13183703.1

Publication Classification

(51) **Int. Cl.**
F24C 15/20 (2006.01)
F24C 15/00 (2006.01)

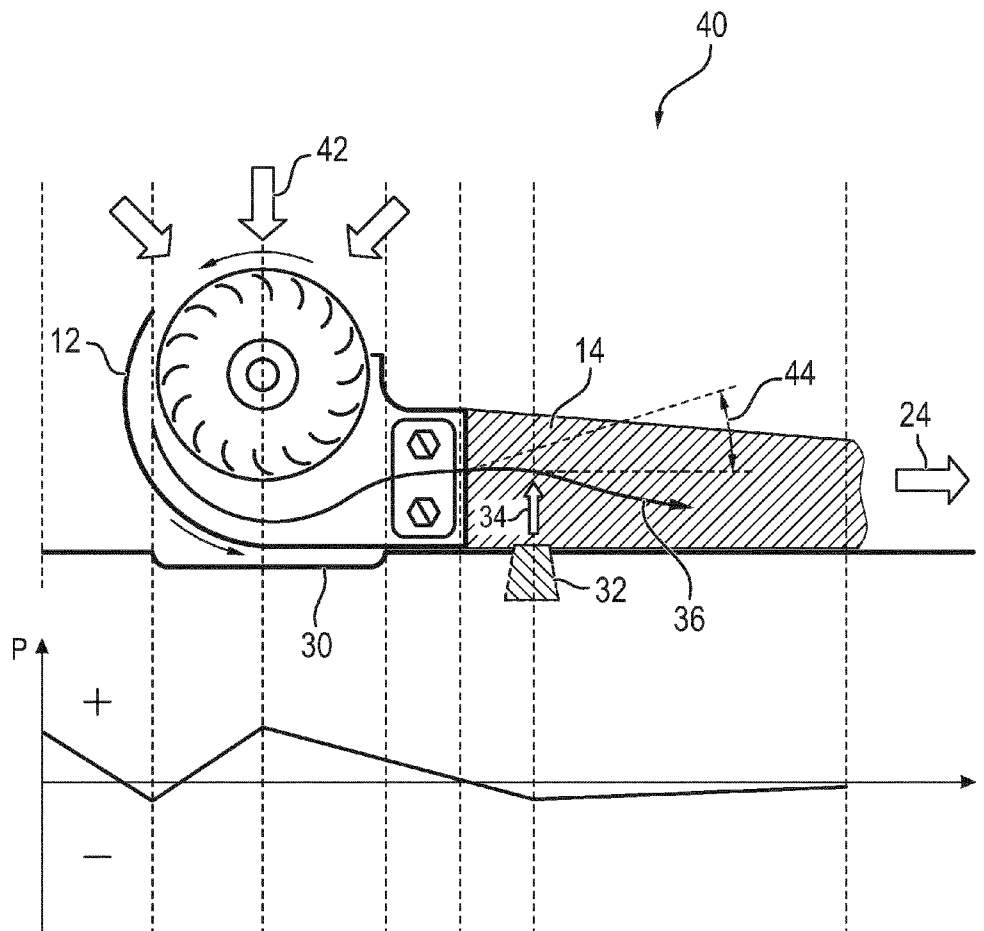

FIG. 1

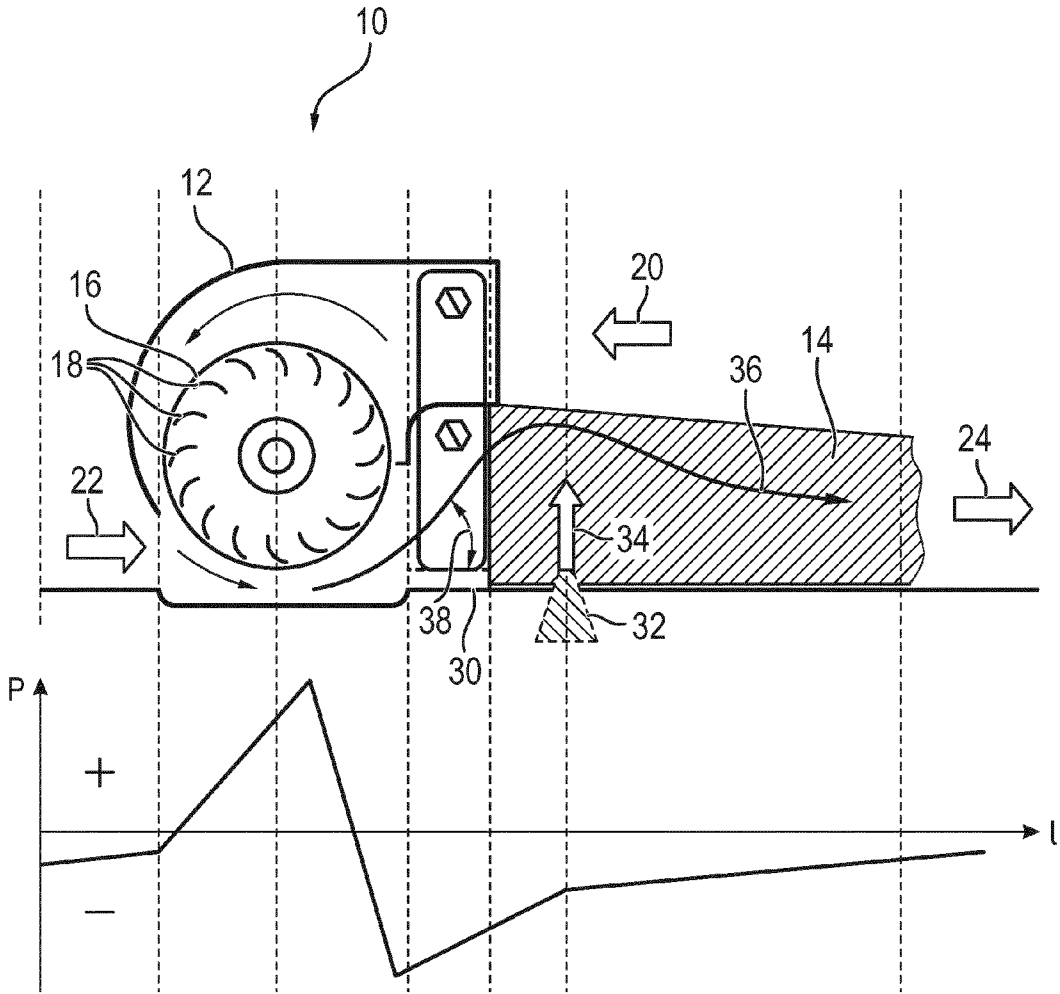

FIG. 2

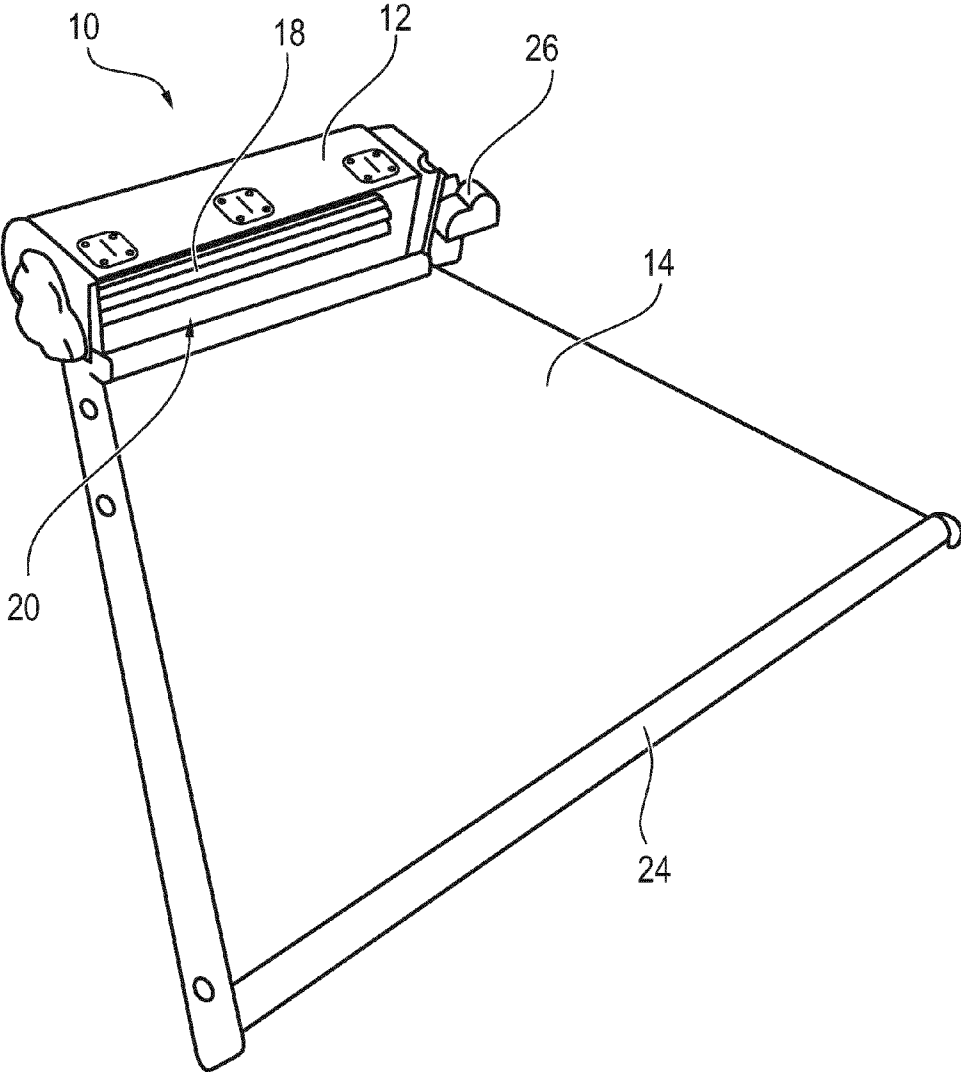

FIG. 3

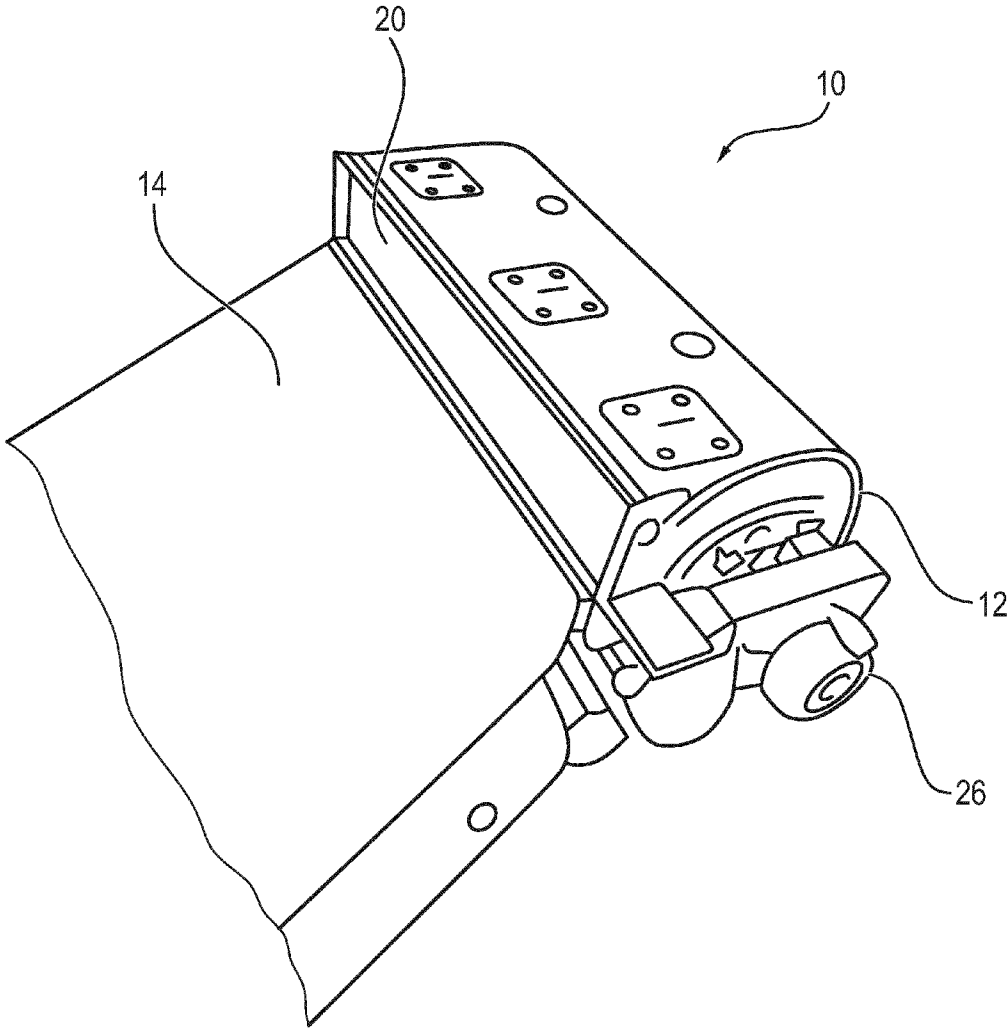

FIG. 4

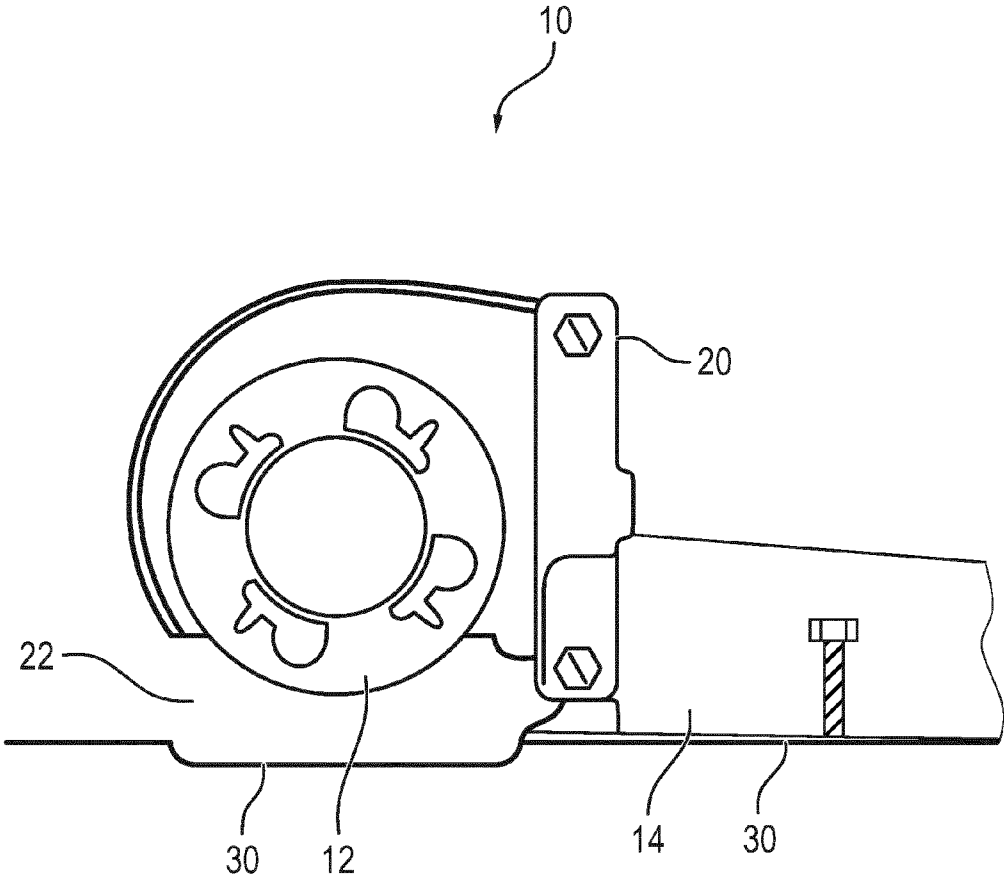

FIG. 5

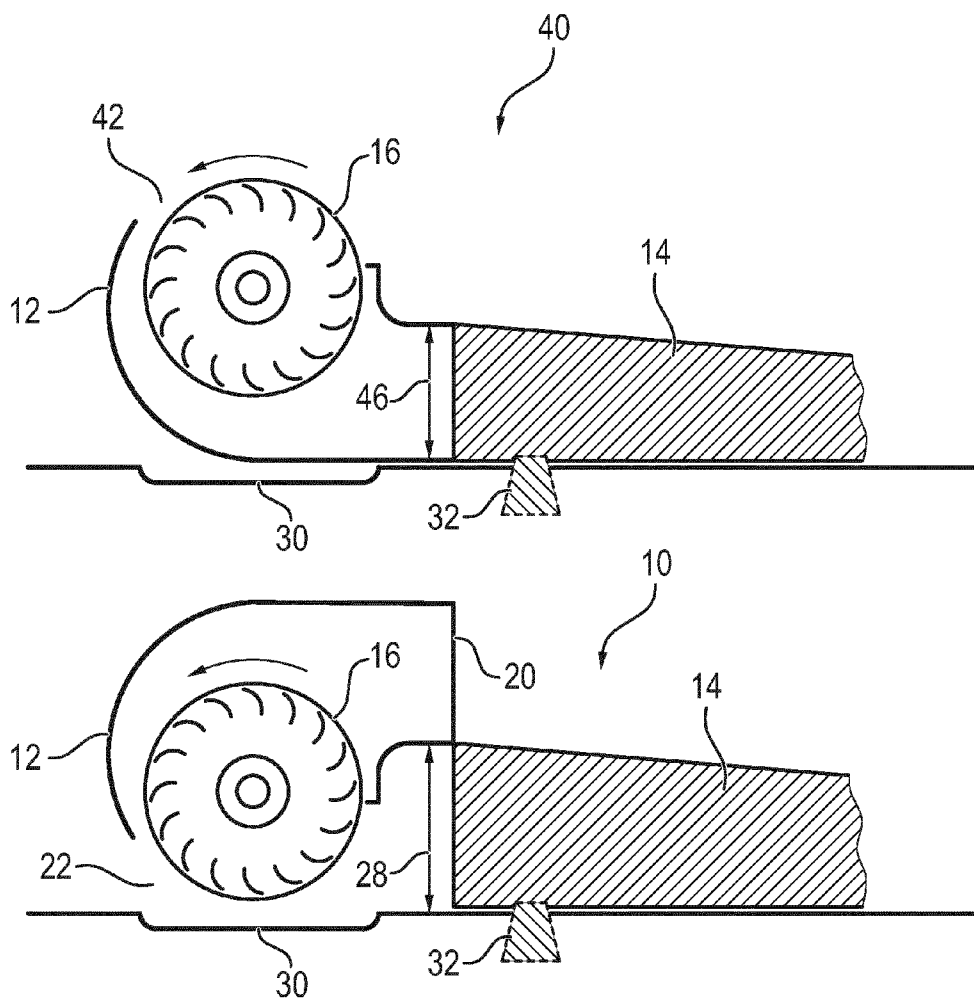
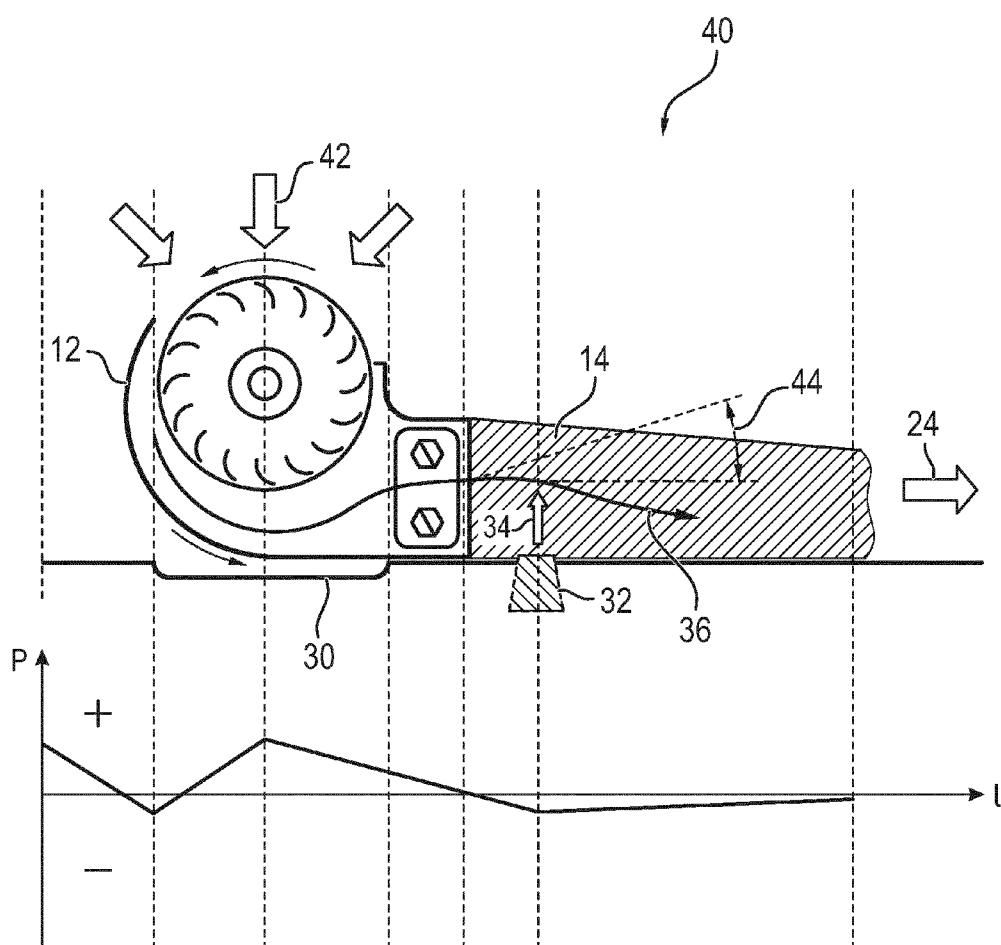

FIG. 6



COOLING AND EXHAUST SYSTEM FOR A COOKING OVEN

[0001] The present invention relates to a cooling and exhaust system, in particular for a cooking oven. Further, the present invention relates to a cooking oven with a cooling and exhaust system.

[0002] Cooling and exhaust systems according to the prior art usually operate with either an axial fan or cross-flow fan. The cooling and exhaust systems with the axial fan provide good results in the high efficiency of a fan shroud. Said fan shroud is able to generate high pressure and an air flow throughout the cooling and exhaust system. However, the axial fan is expensive and results in high costs of the whole cooling and exhaust system. The cooling and exhaust systems with the cross-flow fan causes only low costs and a good efficiency. The cooling and exhaust system with the cross-flow fan is installed above an oven cavity of the cooking oven and directly on a driving plate. A discharging channel of the cooling and exhaust system extends from the rear portion to a front portion of the cooking oven. Vapour and/or hot air are eliminated through the lower part of a control panel of the cooking oven, but sometimes through the upper part of said control panel.

[0003] FIG. 6 illustrates a schematic sectional side view of the cooling and exhaust system 40 and a corresponding pressure-space-diagram according to the prior art. The upper picture represents the cooling and exhaust system 40, while the pressure-space-diagram is shown by the lower picture. The cooling and exhaust system 40 comprises a fan shroud 12 and a discharging channel 14. An impeller 16 with a plurality of fan blades 18 is arranged inside the fan shroud 12. The rotation axis of the impeller 16 extends perpendicular to the plane of the drawing, and the impeller 16 rotates counterclockwise. The fan shroud 12 and the impeller 16 form a cross-flow fan. An inlet 42 is arranged above the impeller 16. The impeller 16 is driven by an electric motor. The impeller 16 rotates in the direction of the action of the forwardly inclined fan blades 18 and generates a strong suction of an air stream from the inlet 42. The air stream follows via a path through the fan shroud 12 and the discharging channel 14 to an outlet 24.

[0004] An exhaust pipe 32 is installed in the bottom of the discharging channel 14 and communicates with the ceiling of the oven cavity. By the operation of the cross-flow fan an air suction and a low pressure zone occurs in the exhaust pipe 32, which extracts the vapours from the oven cavity due to the air stream in the discharging channel 14. The vapours follow the same path as the air stream from the inlet 42 to the outlet 24. The cooling and exhaust system is provided for cooling the components above the oven cavity on the one hand and eliminating the vapours released from the cavity.

[0005] The pressure-space-diagram in the lower picture of FIG. 6 shows the distribution of the static pressure along the cooling and exhaust system 40. The static pressure may have positive and negative values. The distribution of the static pressure depends on the geometry of the fan shroud 12 and on the inner shapes of the cooling and exhaust system 40. Experimental results have shown that the suction pressure remains low around the zone of the exhaust pipe 32 during the operation of the cross-flow fan, since the airflow incident angle relative to the horizontal base plate 30 has a low value. The low static pressure in the zone of the exhaust pipe 32 is disadvantageous, since a consistent mass of vapour remains

inside the oven cavity. Further, the low static pressure in the zone of the exhaust pipe 32 is disadvantageous for the energy consumption.

[0006] It is an object of the present invention to provide an improved cooling and exhaust system, which allows low energy consumption by low complexity and costs.

[0007] The object of the present invention is achieved by the cooling and exhaust system according to claim 1.

[0008] The cooling and exhaust system according to the present invention comprises a fan shroud and a discharging channel, wherein

[0009] an impeller is arranged inside the fan shroud, so that the fan shroud and the impeller form a cross-flow fan,

[0010] the discharging channel is attached at the fan shroud and arranged at the circumferential side of the impeller,

[0011] the discharging channel includes an open end arranged opposite to the fan shroud,

[0012] the discharging channel extends along a horizontal direction,

[0013] a first inlet is arranged in an upper portion of the fan shroud,

[0014] a second inlet is arranged in a lower portion of the fan shroud,

[0015] the first inlet and the second inlet are arranged at or close to opposite circumferential sides of the impeller, and

[0016] an outlet is arranged at the open end of the discharging channel.

[0017] The main idea of the present invention is the cooling and exhaust system with two inlets and one outlet, wherein the both inlets are arranged at opposite sides of the fan shroud. The inlets suck air from different directions. The air is exhausted by the common outlet. The structure of two inlets and one outlet allows an efficient operation of the cooling and exhaust system. The impeller may be driven by reduced power.

[0018] Preferably, the first inlet is arranged above the discharging channel. This contributes to a compact structure of the cooling and exhaust system.

[0019] In particular, the direction of an air stream through the first inlet is opposite to the direction of the air stream inside the discharging channel.

[0020] In contrast, the direction of an air stream through the second inlet may be the same as the direction of the air stream inside the discharging channel.

[0021] In a preferred embodiment of the present invention, a bottom side of the fan shroud is at least partially open, wherein a portion of said bottom side is closed or closable by a base plate, and wherein the base plate is either a part of the cooling and exhaust system or of the cooking oven.

[0022] Further, the position of the base plate may be variable. Thus, an air stream through the cooling and exhaust system follows a path defined by the geometry of the cooling and exhaust system in a predetermined manner.

[0023] In particular, the flow of the air stream through the first inlet is bigger than the flow of the air stream through the second inlet. A main air stream is sucked through the first inlet, while the second inlet sucks an additional air stream.

[0024] Moreover, an exhaust pipe may be arranged in the bottom of the discharging channel, so that the discharging channel is connected or connectable to an oven cavity of the cooking oven. The structure of the two inlets, the one outlet

and the exhaust pipe allows a high negative static pressure in the discharging channel, so that vapours can be removed from the oven cavity of the cooking oven and exhausted through the discharging channel.

[0025] For example, the impeller is driven by an electric motor energized by alternating or direct current.

[0026] In particular, the sum of the air streams through the first inlet and the second inlet is equal to the air stream through the outlet. There are no further inlets and outlets.

[0027] Furthermore, the present invention relates to a cooking oven with the cooling and exhaust system mentioned above.

[0028] Preferably, the first inlet is provided for sucking air from an upper front portion of the cooking oven.

[0029] In particular, the first inlet is provided for sucking air from a space around a control panel of the cooking oven.

[0030] In contrast, the second inlet is provided for sucking air from the rear side of an oven cavity of the cooking oven.

[0031] At last, the base plate may be arranged above the oven cavity of the cooking oven.

[0032] Novel and inventive features of the present invention are set forth in the appended claims.

[0033] The present invention will be described in further detail with reference to the accompanied drawings, in which

[0034] FIG. 1 illustrates a schematic sectional side view of a cooling and exhaust system and a corresponding pressure-space-diagram according to a preferred embodiment of the present invention,

[0035] FIG. 2 illustrates a schematic perspective view of the cooling and exhaust system according to the preferred embodiment of the present invention,

[0036] FIG. 3 illustrates a schematic perspective view of the cooling and exhaust system according to the preferred embodiment of the present invention,

[0037] FIG. 4 illustrates a schematic side view of the cooling and exhaust system according to the preferred embodiment of the present invention,

[0038] FIG. 5 illustrates a schematic sectional side view of the cooling and exhaust system according to the preferred embodiment of the present invention and a further schematic sectional side view of a cooling and exhaust system according to the prior art, and

[0039] FIG. 6 illustrates a schematic sectional side view of the cooling and exhaust system and the corresponding pressure-space-diagram according to the prior art.

[0040] FIG. 1 illustrates a schematic sectional side view of a cooling and exhaust system 10 and a corresponding pressure-space-diagram according to a preferred embodiment of the present invention. In particular, the cooling and exhaust system 10 is provided for a cooking oven. The upper picture in FIG. 1 shows the physical cooling and exhaust system 10, while the pressure-space-diagram is shown by the lower picture in FIG. 1.

[0041] The cooling and exhaust system 10 comprises a fan shroud 12 and a discharging channel 14. The discharging channel 14 is attached at the fan shroud 12. The discharging channel 14 includes an open end opposite to the fan shroud 12. The discharging channel 14 extends along a horizontal direction. An impeller 16 is arranged inside the fan shroud 12. The impeller 16 includes a plurality of fan blades 18. The rotation axis of the impeller 16 extends perpendicular to the plane of the drawing in FIG. 1. The impeller 16 rotates counterclockwise in FIG. 1. The fan blades 18 are inclined in forward direction. The fan shroud 12 and the impeller 16 form

a cross-flow fan. The impeller 16 is driven by an electric motor 26, which is not shown in FIG. 1. The impeller 16 generates a tangential air stream inside the fan shroud 12. Said air stream is set forth inside the discharging channel 14 as a substantially straightforward air stream 36. The cooling and exhaust system 10 includes a base plate 30 at its bottom. A lower part of the fan shroud 12 is formed by a portion of said base plate 30.

[0042] The cooling and exhaust system 10 includes a first inlet 20, a second inlet 22 and an outlet 24. The first inlet 20 is arranged above the junction of the fan shroud 12 and discharging channel 14. The second inlet 22 is arranged at the bottom of the fan shroud 12 and at the circumferential side of the impeller 16. The outlet 24 is arranged at the open end of the discharging channel 14. The first inlet 20 and the second inlet 22 are arranged at opposed circumferential sides of the impeller 16. The direction of the air flow at the first inlet 20 is substantially reversed relating to the direction of the air flow at the outlet 24. In contrast, the direction of the air flow at the second inlet 22 is substantially the same as the direction of the air flow at the outlet 24.

[0043] A bigger part of the sucked air stream passes the first inlet 20, while a smaller part of the sucked air stream passes the second inlet 22. A large mass of fresh air is sucked by the impeller 16 through the first inlet 12 and creates a main air stream inside the cooling and exhaust system 10. For example, said fresh air is sucked from the space around the control panel of the cooking oven, wherein the air around the control panel is replaced by another fresh air pulled into the oven casing from the external environment of the cooking oven. The control panel and its components may be cooled down by the air from the external environment.

[0044] The smaller part of the air stream sucked by the impeller 16 passes the second inlet 22. For example, the air stream sucked through the second inlet 22 is captured from the rear side of an oven cavity of the cooking oven. The air at the rear side of the oven cavity is replaced by fresh air pulled in from the external environment above the cooking oven. The air at the rear side of the oven cavity is generated by heating elements of the cooking oven and accumulated at said rear side of the oven cavity. The second inlet 22 compensates the difference between the air flows of the outlet 24 and the first inlet 20. Thus, the mass of the air stream circulating in the cooling and exhaust system 10 has permanently a constant value.

[0045] The sum of both air streams from the first inlet 20 and second inlet 22 form an air stream 36 inside the discharging channel 14. The air stream 36 exhausts through the outlet 24 at the open end of the discharging channel 14. The air stream from the second inlet 22 deflects the sum of both air streams from the first inlet 20 and second inlet 22, so that the direction of said sum of both air streams has an airflow incident angle 38 with a high value relating to the base plate 30. This is a result of Bernoulli law, in which the sum of the potential energy, kinetic energy and pressure remains constant along a closed aerodynamic channel. The air stream from the second inlet 22 contributes to disturbances, a relative low kinetic energy and a relative high negative pressure at the entry of the discharging channel 14.

[0046] An exhaust pipe 32 is arranged in the bottom of the discharging channel 14. The exhaust pipe 32 is connected or connectable with a ceiling of the oven cavity. The air stream from the second inlet 22 causes the relative high negative pressure above the exhaust pipe 32. This results in a relative

high suction force of the air stream 34 through the exhaust pipe 32. Said high suction force causes of a relative big amount of extracted vapours from the oven cavity. The vapours follow the same path as the air stream 36 inside the discharging channel 14. The cooling and exhaust system 10 is provided for cooling components above the oven cavity on the one hand and eliminating vapours released from the oven cavity.

[0047] The pressure-space-diagram in the lower picture of FIG. 1 shows the distribution of the static pressure along the cooling and exhaust system 10. The static pressure may have positive and negative values characterized by the plus sign and minus sign, respectively. The distribution of the static pressure depends on the geometry of the fan shroud 12 and on the inner shapes of the cooling and exhaust system 10. The suction pressure around the zone of the exhaust pipe 32 is relative high during the operation of the cross-flow fan, since the airflow incident angle 38 relative to the horizontal base plate 30 has a high value. The high static pressure in the zone of the exhaust pipe 32 is an advantage of the present invention, since a lot of vapour is removed from the oven cavity. Further, the high static pressure in the zone of the exhaust pipe 32 is advantageous for the energy consumption.

[0048] FIG. 2 illustrates a schematic perspective view of the cooling and exhaust system 10 according to the preferred embodiment of the present invention. FIG. 2 clarifies the geometric structure of the cooling and exhaust system 10. In the perspective view of FIG. 2 the discharging channel 14 is shown in front of the fan shroud 12.

[0049] The cooling and exhaust system 10 comprises the fan shroud 12 and the discharging channel 14 attached at said fan shroud 12. The outlet 24 is arranged at the open end of the discharging channel 14. The impeller 16 is arranged inside the fan shroud 12. The fan blades 18 of the impeller 16 are partially visible through the first inlet 20. The electric motor 26 is arranged beside the fan shroud 12.

[0050] The electric motor 26 is energized at different voltages. For example, the electric motor 26 is energized by an alternating current at voltages from 110 V to 240 V. Further, the electric motor 26 may be also energized by direct current. For example, the electric power of these electric motors 26 may be vary between 10 W and 45 W. The electric power of the electric motor 26 depends on the current requests. Preferably, the electric motor 26 is of a shaded pole type or a squirrel cage type.

[0051] FIG. 3 illustrates a schematic perspective view of the cooling and exhaust system 10 according to the preferred embodiment of the present invention. In the perspective view of FIG. 3 shows that side of the fan shroud 12, at which the electric motor 26 is attached.

[0052] FIG. 4 illustrates a schematic side view of the cooling and exhaust system 10 according to the preferred embodiment of the present invention.

[0053] The discharging channel 14 attached at said fan shroud 12. The outlet 24 is arranged at the open end of the discharging channel 14. The impeller 16 is arranged inside the fan shroud 12. The fan blades 18 of the impeller 16 are partially visible through the first inlet 20. The electric motor 26 is arranged beside the fan shroud 12, but not visible in FIG. 4. The first inlet 20 and the second inlet 22 are arranged at the opposed circumferential sides of the fan shroud 12.

[0054] FIG. 5 illustrates a schematic sectional side view of the cooling and exhaust system 10 according to the preferred embodiment of the present invention and a further schematic

sectional side view of a cooling and exhaust system 40 according to the prior art. An upper picture in FIG. 5 shows the cooling and exhaust system 40 according to the prior art, while a lower upper picture in FIG. 5 shows the cooling and exhaust system 10 according to the present invention. The cooling and exhaust system 10 according to the preferred embodiment is compared with cooling and exhaust system 40 of the prior art.

[0055] The discharging channels 14 of the present invention and the prior art have different heights 28 and 46. A height 28 of the discharging channel 14 of the inventive cooling and exhaust system 10 is bigger than a corresponding height 46 of the discharging channel 14 of the inventive cooling and exhaust system 40 according to the prior art. In order to avoid unwanted vibrations generated by induction, the electric motor 26 should be arranged at a minimum height. Preferably, the distance between the electric motor 26 and the bottom of the base plate 30 should be at least 10 mm. The residual dimensions of the both cooling and exhaust systems 10 and 40 are substantially the same.

[0056] FIG. 6 illustrates a schematic sectional side view of the cooling and exhaust system 40 and the corresponding pressure-space-diagram according to the prior art. The upper picture represents the cooling and exhaust system 40, while the pressure-space-diagram is shown by the lower picture. The cooling and exhaust system 40 comprises the fan shroud 12 and the discharging channel 14. The impeller 16 with the plurality of fan blades 18 is arranged inside the fan shroud 12. The rotation axis of the impeller 16 extends perpendicular to the plane of the drawing. The impeller 16 rotates counter-clockwise. The fan shroud 12 and the impeller 16 form the cross-flow fan. An inlet 42 is arranged above the impeller 16. The impeller 16 is driven by the electric motor. The impeller 16 rotates in the direction of the action of the forwardly inclined fan blades 18 and generates the strong suction of an air stream from the inlet 42. The air stream follows via the path through the fan shroud 12 and the discharging channel 14 to the outlet 24.

[0057] The exhaust pipe 32 is installed in the bottom of the discharging channel 14 and communicates with the ceiling of the oven cavity. By the operation of the cross-flow fan the air suction and low pressure zone occurs in the exhaust pipe 32, which extracts the vapours from the oven cavity due to the air stream in the discharging channel 14. The vapours follow the same path as the air stream from the inlet 42 to the outlet 24. Also the cooling and exhaust system 40 is provided for cooling the components above the oven cavity on the one hand and eliminating the vapours released from the cavity.

[0058] The pressure-space-diagram in the lower picture of FIG. 6 shows the distribution of the static pressure along the cooling and exhaust system 40. The static pressure has positive and negative values. The distribution of the static pressure depends on the geometry of the fan shroud 12 and on the inner shapes of the cooling and exhaust system 40. The suction pressure remains low around the zone of the exhaust pipe 32 during the operation of the cross-flow fan, since the airflow incident angle 44 relative to the horizontal base plate 30 has a low value. The low static pressure in the zone of the exhaust pipe 32 is disadvantageous, since a consistent mass of vapour remains inside the oven cavity. Further, the low static pressure in the zone of the exhaust pipe 32 is disadvantageous for the energy consumption.

[0059] Although an illustrative embodiment of the present invention has been described herein with reference to the

accompanying drawings, it is to be understood that the present invention is not limited to that precise embodiment, and that various other changes and modifications may be affected therein by one skilled in the art without departing from the scope or spirit of the invention. All such changes and modifications are intended to be included within the scope of the invention as defined by the appended claims.

LIST OF REFERENCE NUMERALS

- [0060] 10 cooling and exhaust system
- [0061] 12 fan shroud
- [0062] 14 discharging channel
- [0063] 16 impeller
- [0064] 18 fan blade
- [0065] 20 first inlet
- [0066] 22 second inlet
- [0067] 24 outlet
- [0068] 26 electric motor
- [0069] 28 height of the discharging channel 14
- [0070] 30 base plate
- [0071] 32 exhaust pipe
- [0072] 34 air stream through the exhaust pipe 32
- [0073] 36 air stream inside the discharging channel 14
- [0074] 38 airflow incident angle inside the discharging channel 14
- [0075] 40 cooling and exhaust system of the prior art
- [0076] 42 inlet
- [0077] 44 airflow incident angle inside the discharging channel 14
- [0078] 46 height of the discharging channel 14
- [0079] P pressure
- [0080] l length

1. A cooling and exhaust system, in particular for a cooking oven, comprising a fan shroud and a discharging channel, wherein

an impeller is arranged inside the fan shroud, so that the fan shroud and the impeller form a cross-flow fan, the discharging channel is attached at the fan shroud and arranged at the circumferential side of the impeller, the discharging channel includes an open end arranged opposite to the fan shroud, the discharging channel extends along a horizontal direction, a first inlet is arranged in an upper portion of the fan shroud, a second inlet is arranged in a lower portion of the fan shroud, the first inlet and the second inlet are arranged at or close to opposite circumferential sides of the impeller, and an outlet is arranged at the open end of the discharging channel.

2. The cooling and exhaust system according to claim 1, characterized in that the first inlet is arranged above the discharging channel.

3. The cooling and exhaust system according to claim 1, characterized in that the direction of an air stream through the first inlet is opposite to the direction of the air stream inside the discharging channel.

4. The cooling and exhaust system according to claim 1, characterized in that

the direction of an air stream through the second inlet is the same as the direction of the air stream inside the discharging channel.

5. The cooling and exhaust system according to claim 1, characterized in that

a bottom side of the fan shroud is at least partially open, wherein a portion of said bottom side is closed or closable by a base plate, and wherein the base plate is a part of the cooling and exhaust system or of the cooking oven.

6. The cooling and exhaust system according to claim 5, characterized in that

the position of the base plate is variable, so that an air stream through the cooling and exhaust system follows a path defined by the geometry of the cooling and exhaust system in a predetermined manner.

7. The cooling and exhaust system according to claim 1, characterized in that

the flow of the air stream through the first inlet is bigger than the flow of the air stream through the second inlet.

8. The cooling and exhaust system according to claim 1, characterized in that

an exhaust pipe is arranged in the bottom of the discharging channel so that the discharging channel is connected or connectable to an oven cavity of the cooking oven.

9. The cooling and exhaust system according to claim 1, characterized in that

the impeller is driven by an electric motor energized by alternating or direct current.

10. The cooling and exhaust system according to claim 1, characterized in that

the sum of the air streams through the first inlet and the second inlet is equal to the air stream through the outlet.

11. A cooking oven with a cooling and exhaust system, characterized in that

the cooking oven comprises the cooling and exhaust system according to claim 1.

12. The cooking oven according to claim 11, characterized in that

the first inlet is provided for sucking air from an upper front portion of the cooking oven.

13. The cooking oven according to claim 12, characterized in that

the first inlet is provided for sucking air from a space around a control panel of the cooking oven.

14. The cooking oven according to claim 11, characterized in that

the second inlet is provided for sucking air from the rear side of an oven cavity of the cooking oven.

15. The cooking oven according to claim 11, characterized in that

a bottom side of the fan shroud is at least partially open, wherein a portion of said bottom side is closed or closable by a base plate, wherein the base plate is arranged above an oven cavity of the cooking oven.

* * * * *