





(No Model.)

6 Sheets—Sheet 3.

W. E. GORTON.  
COCKLE SEPARATING MACHINE.

No. 256,674.

Patented Apr. 18, 1882.

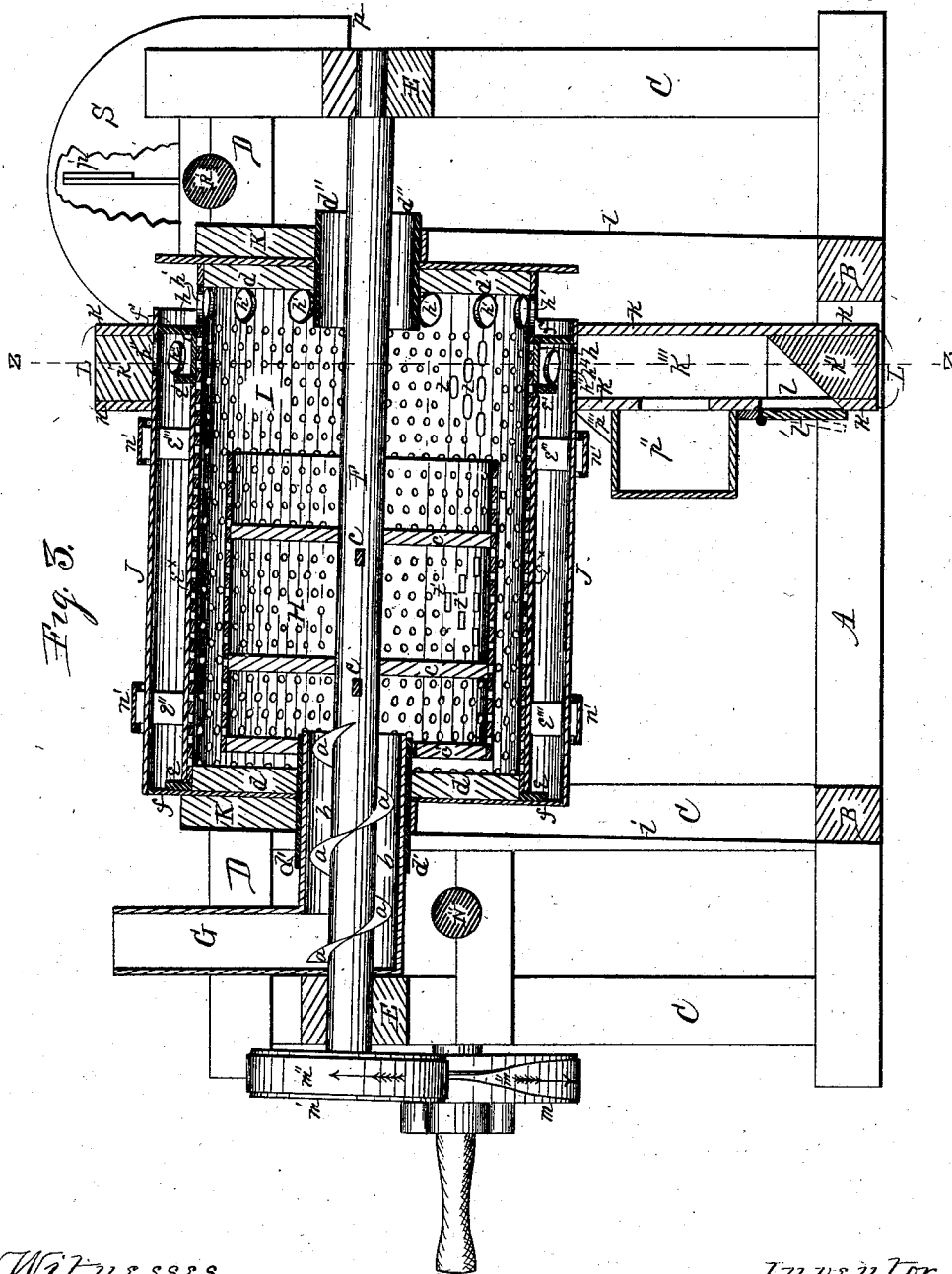

Fig. 3.

Witnesses,  
H. B. Bardin.  
A. O. Behel

Inventor,  
William E. Gorton.  
Per. Jacob Behel.  
Atty.



(No Model.)

6 Sheets—Sheet 5.

W. E. GORTON.  
COCKLE SEPARATING MACHINE.

No. 256,674.

Patented Apr. 18, 1882.

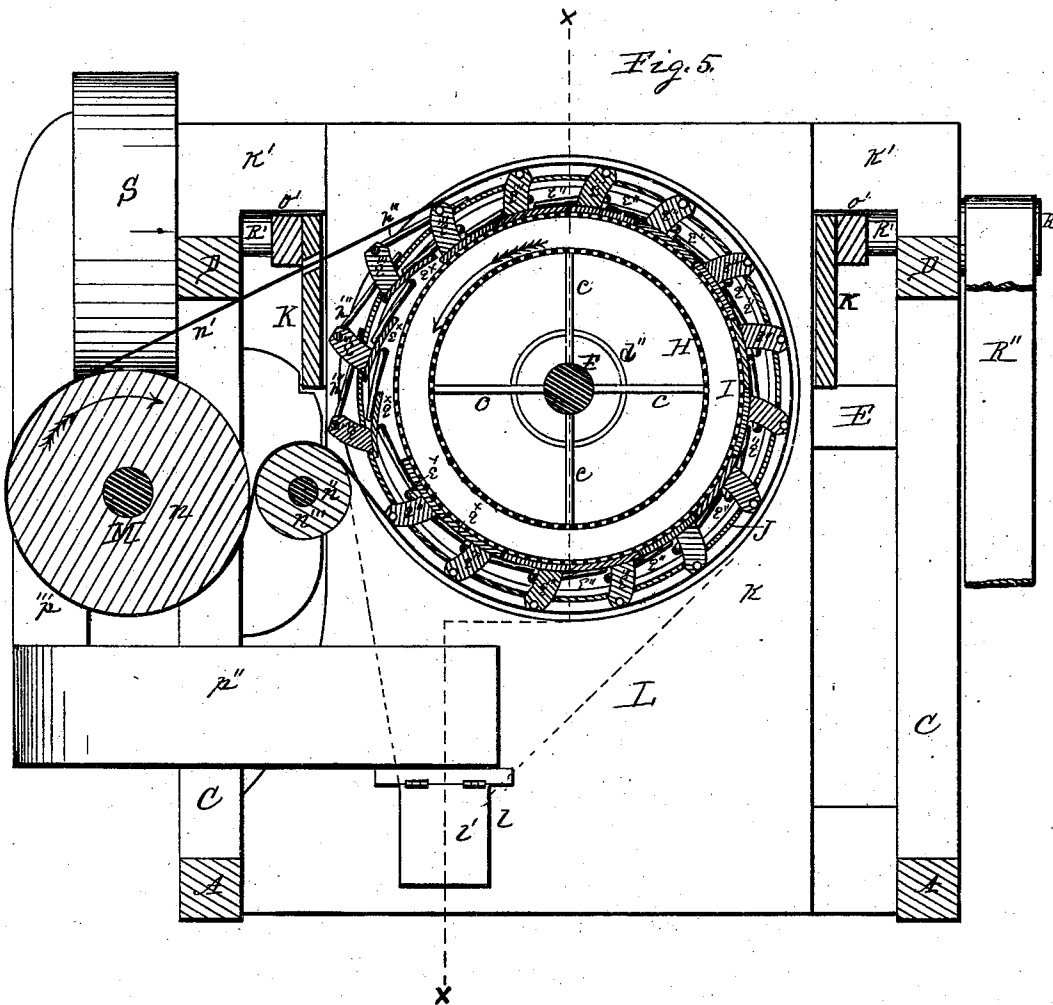
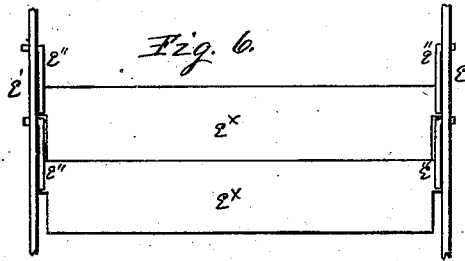

Witnesses,  
M. G. Bardin  
A. Behel

Inventor  
William E. Gorton.  
Per Jacob Behel  
Atty.

(No Model.)

6 Sheets—Sheet 6.

# W. E. GORTON. COCKLE SEPARATING MACHINE.

No. 256,674.

Patented Apr. 18, 1882.

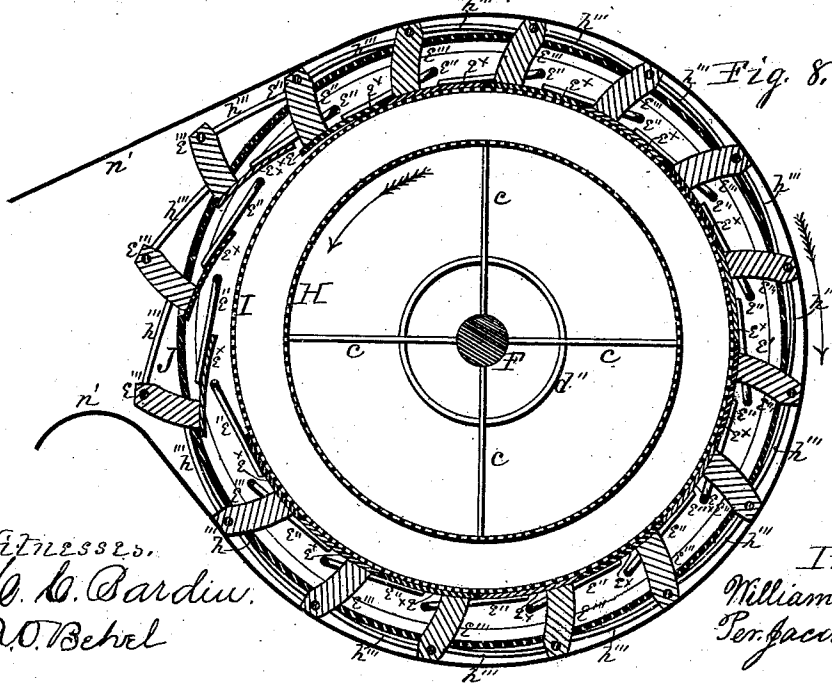
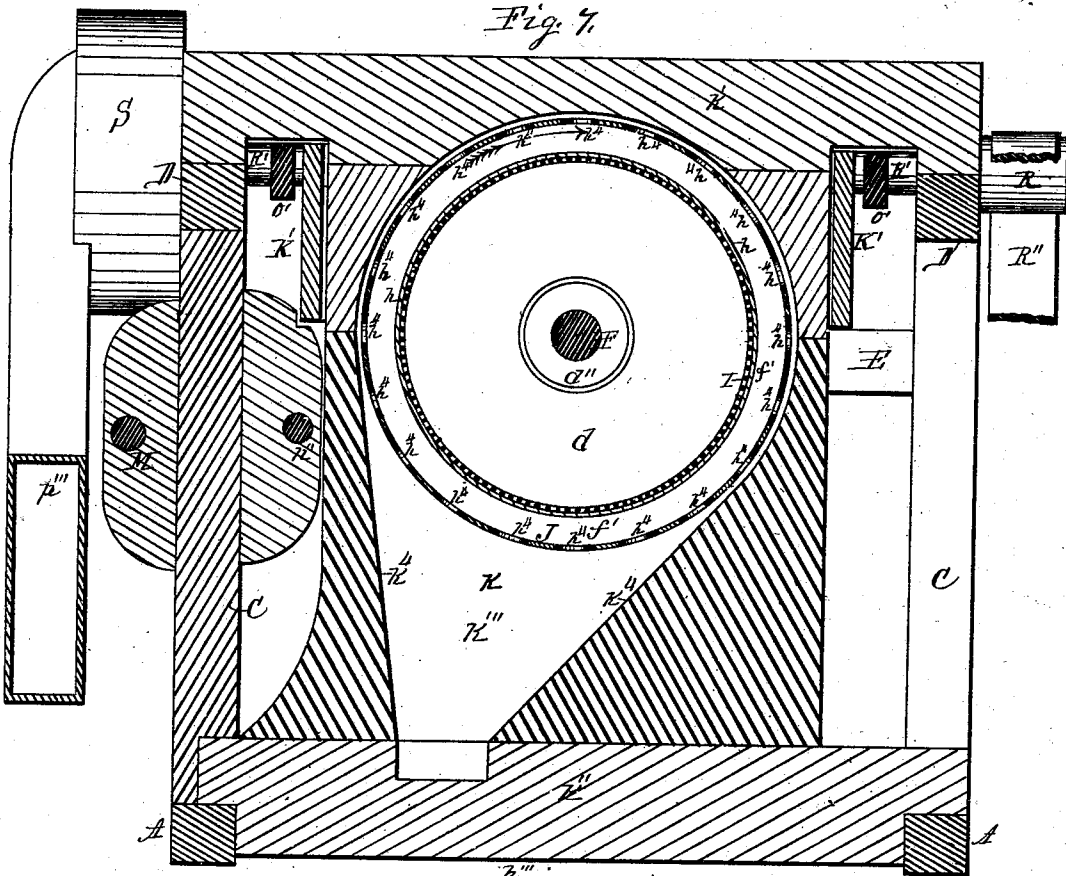

Witnesses:  
*M. S. Bardin.*  
*A. O. Behel*

Inventor:  
*William E. Gorton.*  
*Per Jacob Behel.*  
*Atty.*

# UNITED STATES PATENT OFFICE.

WILLIAM E. GORTON, OF EAU CLAIRE, WISCONSIN.

## COCKLE-SEPARATING MACHINE.

SPECIFICATION forming part of Letters Patent No. 256,674, dated April 18, 1882.

Application filed October 11, 1881. (No model.)

To all whom it may concern:

Be it known that I, WILLIAM E. GORTON, a citizen of the United States, residing at Eau Claire, in the county of Eau Claire, in the State of Wisconsin, have invented certain new and useful Improvements in Cockle-Separating Machines, of which the following is a specification.

My invention relates to improvements in machines employed to separate cockle, garlic, and other small seeds from wheat or rye or other grains; and its object is to provide an efficient separator having an increased capacity relatively with its size. To this end I have designed and constructed the machine represented in the accompanying drawings, in which—

Figure 1 is an isometrical representation of a machine embodying my invention, of which Fig. 2 is a plan view; Fig. 3, a lengthwise central vertical section on dotted line *x*, Fig. 5; Fig. 4, a transverse vertical section of the hopper or receiving-end portion cut on the dotted line *y*, Fig. 2; Fig. 5, a transverse vertical section of the delivery-end portion cut on the dotted line *x x*, Fig. 2; and Fig. 6 represents a section of the outer perforated cylinder, showing the stave-jacket connection therewith. Fig. 7 is a transverse vertical section of the delivery end on dotted line *Z*, Fig. 3; and Fig. 8 is an enlarged transverse vertical section of the delivery-end portion of the perforated cylinder and its attachments on dotted line *x x*, Fig. 2.

In the figures, A represents the lengthwise or side sills, and B the end or transverse sills, of a frame rectangular in plan.

At C are represented corner and intermediate posts, which are framed or otherwise suitably joined to the side sills, from which they rise and support the lengthwise beams D, which are framed or otherwise securely fixed on their upper ends.

At E are represented transverse beams, suitably framed into or otherwise securely fixed to the vertical posts. These several beams are of suitable dimensions, rectangular in section, and framed or joined to each other in the manner and form shown and described, and constitute the supporting-frame of my improved machine.

At F is represented a conveyer-shaft, suitably mounted to revolve in bearings on the transverse beams centrally in the width of the frame, having one of its end portions provided with spiral conveyer-blades *a*, suitably fixed to the shaft. This shaft is slightly inclined, being highest at its head or conveyer end.

At G is represented a hopper provided with a horizontal tubular portion, *b*, adapted to receive the conveyer portion of the shaft F. This hopper is fixed to the inner side of the transverse end bar of the frame in such position thereon that its tubular portion will be concentric with the conveyer-shaft, and will increase the conveyer portion thereof in such a manner that the revolutions of the shaft will carry the grain deposited in the hopper through the tubular portion thereof.

At H is represented a cylinder made from plate material, perforated, and mounted upon the conveyer-shaft, supported thereon by means of cross-arms *c*, framed into the shaft at right angles to each other. This perforated cylinder is provided at one end with a head, *c'*, having a central opening to receive the tubular bearing of an outer cylinder.

At I is represented a cylinder made from perforated-plate material, and of greater diameter than the inner perforated cylinder, H. This cylinder is provided with ends *d*, to which the perforated-plate cylinder is fixed. These ends are provided with axial tubular journals *d'* and *d''*, of which the tubular journal *d'* receives the tubular portion *b* of the hopper in such a manner as to revolve thereon freely.

At *e* and *e'* are represented annular rings, placed on the outside and end portions of this perforated cylinder, between which this outer perforated cylinder is provided with a jacket, made in stave-like sections *e<sup>x</sup>*, having their end portions fitted with hinged arms *e''*, the hook-end portions of which are pivoted in the annular rings in such manner that the several stave-like portions forming the jacket are independently hinged and capable of opening outward from and closing onto the perforated cylinder independently, and when closed form a close-fitting jacket to the cylinder. These stave-like portions, toward their ends, are provided with outward-projecting arms *e'''*, preferably of some elastic material, as leather or

rubber, and are of suitable form and size to extend outward through suitable openings in the outer jacket.

At  $f$  is represented a metallic disk-head, fixed to the outside of the end  $d$  in the head end of the outer perforated cylinder. This metallic disk-head is of greater diameter than the perforated cylinder and extends beyond its periphery.

At  $f'$  is represented an annular ring, the outer diameter of which is the same as the disk-head  $f$ , and its inner diameter is of proper dimensions to receive the perforated cylinder, on which it is placed in position near the delivery end thereof.

At  $h$  is represented a close-fitting jacket, placed upon the perforated cylinder  $I$  between the annular rings  $e'$  and  $f'$ , employed to close the perforations between the rings; but this jacket may be dispensed with when that portion of the cylinder over which this jacket is placed is not perforated. This perforated cylinder, near its delivery end, outside of the annular ring  $f'$ , is provided with delivery or outlet openings  $h'$ , through which the cleaned grain is discharged from the cylinder.

At  $J$  is represented an outer jacket of plate material, supported on the periphery of the disk-head  $f$  and annular ring  $f'$ . This jacket, at proper intervals, is provided with suitable openings,  $h''$ , to permit the elastic arms  $e'''$  to project outward through them.

At  $h'''$  are represented springs—in this instance of wire—bent in any suitable form, and fixed to the outside of the outer jacket, having their free ends inserted in holes in the outer end portions of the elastic arms  $e'''$  of the several sections of the stave-formed jacket, operating to carry the several staves from the perforated cylinder when in position to be free to rise. The delivery-end portion of this outer jacket is provided with delivery or outlet openings  $h^4$ , through which the cockle and other matter separated from the grain is discharged from the jacket. This cylinder, consisting of its several parts, constructed and arranged substantially in the manner hereinbefore described and shown, is mounted on its tubular journals to revolve in suitable bearings in a box-like frame, consisting of end beams,  $K$ , and side beams,  $K'$ , suitably framed or joined to each other. This frame, with the cylinder mounted to revolve therein, is supported in position in the main frame to hold the cylinder concentric with the conveyer-shaft by means of spring-bars  $i$ , having their lower ends securely fixed to the transverse sills and their upper ends firmly fixed to the end beams of cylinder-supporting frame. These spring-bars hold the cylinder in position to rotate on the same axial center of the conveyer-shaft and in such manner as to permit an endwise reciprocating or shivering movement.

At  $L$  is represented a vertical transverse spout-like division within the side walls of the cylinder-frame, formed by means of the vertical transverse walls  $k$ , which are fixed at their up-

per ends to a transverse beam,  $k'$ , fixed to the upper surface of the side beams of the main frame, and at their lower ends are fixed to a transverse sill,  $k''$ , fixed to the side sills thereof, forming a vertical spout-like compartment,  $k'''$ . The vertical walls of this compartment are provided with circular openings concentric with the axial center of the conveyer-shaft, and of proper size to admit the delivery end of the cylinder to permit it to revolve therein freely. The position of this vertical spout is such relatively with the cylinder that the discharge-openings of the outer jacket of the cylinder will be within its walls to discharge the contents of the jacket within the spout. That portion of the spout on the under portion of the cylinder is provided with inclined end walls,  $K^4$ , which are also represented in the dotted lines in Fig. 5, employed to conduct the contents of the spout to the outlet-opening  $l$ , which is provided with a hinged door,  $l'$ , to close the opening against the inflowing current of air produced by the action of the exhaust-fan, but will yield to the pressure of the accumulations of the discharges of the outer jacket of the cylinder to permit their discharge.

At  $M$  is represented a driving-shaft supported in a horizontal position on the outside of the main frame, to revolve in suitable bearings fixed to the vertical posts thereof. This driving-shaft is designed to have a suitable connection with a prime mover, and it is provided with a belt-pulley,  $m$ , which is connected with a like pulley,  $m'$ , by means of a cross-belt,  $m''$ . This driving-shaft is also provided with pulleys  $n$  in position to receive the belts  $n'$ , which encircle the cylinder on the line of the outward-projecting elastic arms  $e'''$ .

At  $n''$  is represented a horizontal shaft, placed parallel to the driving-shaft, supported to revolve in suitable bearings on the inside of the vertical posts of the main frame. On this shaft are mounted idle pulleys  $n'''$ , in the same transverse vertical plane with the pulleys  $n$ , and employed to change the direction of the belts  $n'$  on their under side to cause them to engage the periphery of the cylinder to a greater extent, and consequently to hold the stave-jacket to the periphery of the perforated cylinder to a higher point on their ascending side. On this driving-shaft is mounted a beveled toothed gear-wheel,  $N$ , the teeth of which engage the teeth of a beveled toothed pinion,  $N'$ , mounted on the end of a transverse shaft,  $N''$ , supported to revolve in suitable bearings on the main frame. This transverse shaft extends to the outside of the main frame, and on its outward-projecting end is mounted a belt-pulley,  $P$ . This pulley is connected with a belt-pulley,  $R$ , on the outward-projecting end of a transverse fan-shaft,  $R'$ , by means of a belt,  $R''$ . This transverse fan-shaft is supported to revolve in suitable bearings on the lengthwise beams of the main frame, and immediately on the inside of its bearings it is made in eccentric or crank form, as at  $o$ , on which are fixed by suitable box-connections spring bar-pitmen  $o'$ , having

their opposite ends, as at  $o''$ , fixed to the side beams of the cylinder-frame, near the head ends thereof.

At  $S$  is represented a fan-case, circular in plan, fitted with a discharge-opening,  $p$ , and of proper dimensions to receive a suitable exhaust-fan,  $p'$ , mounted on the end of the fan-shaft, which extends into the case.

At  $p''$  is represented a horizontal portion of an exhaust-air tube, one end of which connects with the spout-compartment  $k'''$  immediately above the door  $l'$  of the outlet-opening  $l$ . The outer end of this tube connects with its upright portion  $p'''$ , the upper end of which connects with the open eye-center of the fan-case. By this arrangement a connection of the exhaust-fan is made with the chamber of the cylinder, formed by the outer jacket.

From the foregoing it will be seen that if motion is imparted to the driving-shaft in the direction of the arrow motion will be imparted to the several parts, causing them to rotate in the direction indicated by the arrows thereon, from which it will be seen that the conveyer-shaft and the inner perforated cylinder mounted thereon and the outer perforated cylinder with its stave-like jacket and the outer jacket will revolve in opposite directions, and by means of the eccentric and pitman-connection an endwise-reciprocating or shivering-like movement will be imparted to the cylinder.

It will also be seen that in the rotations of the cylinders the belts  $n'$  will operate to depress the arms protruding through the jacket and will hold the stave-like jacket to the perforated cylinder while acted upon by the belts, and when relieved from action or pressure of the belts the several independent stave-like portions of the jacket will rise from the periphery of the perforated cylinder by means of the action of the springs connected with the elastic arms projecting from their outer surface.

In the use of my improved machine the grain to be operated upon is placed in the hopper in contact with the conveyer, and with the machine in motion it will be carried by the action of the conveyer into the perforated inner cylinder mounted on the conveyer-shaft and rotating therewith, the action of which will cause the cockle and smaller seeds to pass through the perforations onto the inner surface of the outer perforated cylinder, and the larger grains will be carried on the inner surface of the inner cylinder, and by reason of its endwise inclination will be discharged from its open end onto the inner surface of the outer perforated cylinder, to be carried thereon and discharged through the outlet-openings  $h'$  in its outer end. During this operation the cockle and other seeds deposited on the inner surface of the outer perforated cylinder will settle into the perforations therein, resting on the inner surface of the stave-formed jacket, and in its rotations will be carried therein to the point at which the stave-formed jacket is

opened from the cylinder, when they will drop from the perforations onto the inner surface of the outer jacket, on which they will be carried on its inclined surface and delivered through the outlet-openings  $h''$  into the spout-compartment  $k''$ , to be discharged through the openings  $l$ .

From this construction of the parts and the operation it will be seen that the exhaust-fan receives its air-supply mainly from the cylinders, which action will operate to carry from the cylinders through the perforations all light material of a size that will freely pass through the perforations, and will operate in connection with the springs to open the stave-formed jacket, and will also carry outward the cockle and other seeds contained in the perforations of the cylinder.

In a well-constructed machine the springs employed to open the stave-formed jacket may be dispensed with, and the action of the exhaust will be found sufficient to open the stave-like sections thereof.

My machine is capable of use as an efficient separator without either the inner perforated cylinder or the vibrating or shivering endwise movement; but the omission of both or either of these features will lessen its capacity.

By the employment of cylinders provided with elongated openings, substantially such as represented at  $t$  or  $t'$  in Fig. 3, my machine may be successfully employed as a grading-machine to separate the smaller from the larger grains, and these may be varied to adapt the machine to grade the various kinds of grain.

I claim as my invention—

1. The combination, with the main frame and the conveyer-shaft mounted thereon, of the cylinder-supporting frame and a perforated cylinder provided with tubular bearings and mounted concentric with said shaft, substantially as set forth.

2. The combination, with a perforated rotary cylinder, of an outer jacket formed of pivoted staves or sections adapted to automatically open and close when the machine is in operation, as and for the purpose set forth.

3. The combination, with the perforated cylinder and a stave-formed jacket, the several staves of which are capable of independent action, of an outer concentric jacket provided with suitable openings to receive the several staves of the stave-formed jacket, as and for the purpose described.

4. The combination, with the inner jacket, provided with the stave portions, and the outer jacket, of springs fixed to the outer jacket having their free ends connected with the outwardly-projecting arms of the staves of the inner jacket, substantially as set forth.

5. The combination, with the perforated cylinder, the jacket provided with stave portions, and the outer jacket, of belts operating to impart a rotary motion to the cylinder and to close the stave-jacket onto the perforated cylinder, substantially as set forth.

6. The combination, with the cylinder having the end portion of its jacket provided with outlet-openings, of a spout-like apartment to receive the discharged contents of the jacket and deliver them through an outlet-opening, substantially as set forth.

7. The combination, with the perforated cyl-

inder provided with the stave-like jacket, of an exhaust-fan and pipe, arranged substantially as set forth.

WILLIAM E. GORTON.

Witnesses:

S. C. BROOKS,

J. H. KEAN.