

FIGURE 1

Ashish

(Ashish Sharma)

Authorized Agent for the Applicant

Indian Patent Agent Regn No. IN/PA-3021

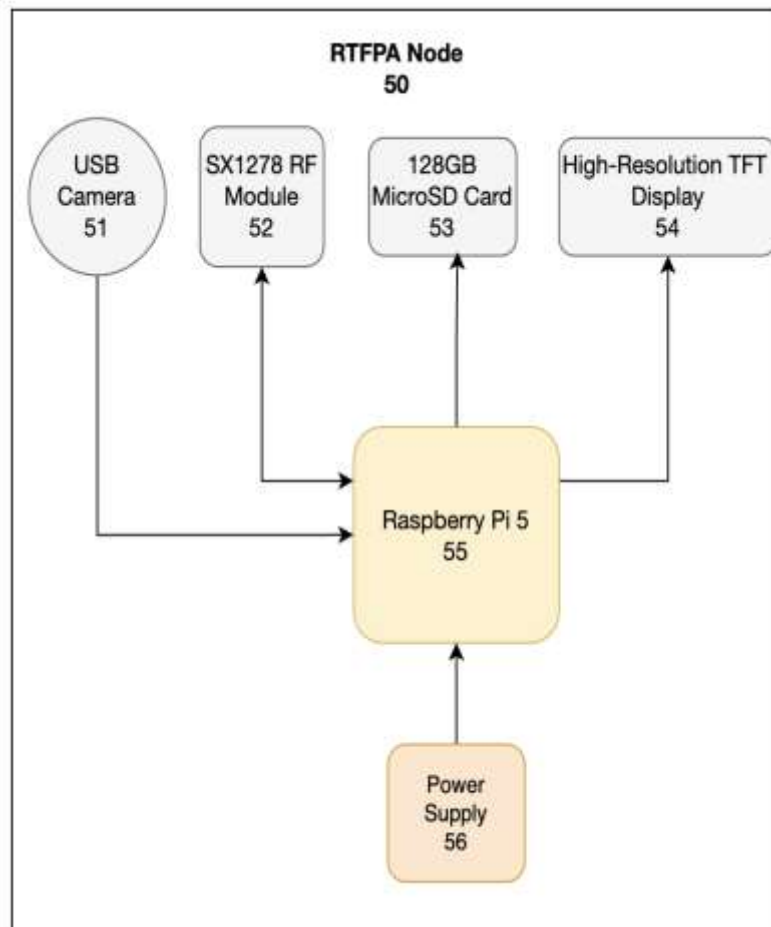

FIGURE 2

Ashish

(Ashish Sharma)

Authorized Agent for the Applicant

Indian Patent Agent Regn No. IN/PA-3021

FORM 2

THE PATENTS ACT 1970

(39 of 1970)

&

THE PATENT RULES, 2003

COMPLETE SPECIFICATION

(See section 10 and rule 13)

1. TITLE OF THE INVENTION: -

**AN AUTOMATED AI-POWERED BUSINESS PLAN GENERATOR SYSTEM WITH
REAL-TIME MARKET RESEARCH AND FINANCIAL PROJECTION CAPABILITIES**

2. Applicant(s)

NAME	NATIONALITY	ADDRESS
GALGOTIAS UNIVERSITY	INDIAN	PLOT NO.2, SECTOR 17-A YAMUNA EXPRESSWAY, OPPOSITE BUDDHA INTERNATIONAL CIRCUIT, GREATER NOIDA, GAUTAM BUDDH NAGAR, UTTAR PRADESH 203201

3. PREAMBLE OF THE DESCRIPTION

The following specification particularly describes the invention and the manner in which it is to be performed

TITLE OF THE INVENTION

An Automated AI-Powered Business Plan Generator system with Real-Time Market Research and Financial Projection Capabilities

FIELD OF THE INVENTION

- 5 This invention relates to Automated AI-Powered Business Plan Generator system with Real-Time Market Research and Financial Projection Capabilities.

BACKGROUND OF THE INVENTION

The Automated AI-Powered Business Plan Generator with Real-Time Market Research and Financial Projection Capabilities is an innovative system designed to streamline and enhance
10 business planning by leveraging artificial intelligence and real-time data analysis. This system autonomously gathers and processes market intelligence, competitor insights, and industry trends to generate comprehensive and data-driven business plans. It integrates advanced algorithms to analyze historical and live financial data, providing accurate projections, risk assessments, and strategic recommendations. The solution is capable of dynamically adapting
15 to market fluctuations, ensuring up-to-date business planning with precise financial forecasting. The system offers a seamless, automated approach to business plan creation, eliminating manual inefficiencies and empowering entrepreneurs, startups, and enterprises with actionable insights for informed decision-making.

Traditional business planning is often time-consuming, reliant on outdated data, and prone to
20 human biases, making it challenging for entrepreneurs and enterprises to make informed decisions. The lack of real-time market insights and accurate financial projections can lead to flawed strategies, missed opportunities, and financial instability. Additionally, manual research and forecasting require significant expertise and resources, making it inaccessible for startups

and small businesses. This invention addresses these challenges by automating the entire process, leveraging real-time data analysis and AI-driven insights to generate precise business plans and financial forecasts. By eliminating inefficiencies and ensuring data-driven decision-making, this system empowers users to adapt to dynamic market conditions, optimize financial strategies, and enhance business success.

US20230075411A1 A system and method for automated personalized financial planning is disclosed. The financial planning system includes a data receiving module for receiving a data input of at least one user account, a target information from the user. A manager module manages the data input. Further in, a machine-learning based prediction module derive learning from the data input for predicting a cashflow information. The financial planning system includes a planning module generating a financial plan based on the data input comprising of recommendation for achieving the target information.

RESEARCH GAP: Business planning with real-time market research and financial projection based on AI, whereas the referenced patents focus only on financial planning or market analysis separately is the uniqueness of this innovation.

US6453303B1 A system is provided for automatically generating and displaying market analysis related to financial assets whereby the analysis is provided for substantially all financial assets. The system includes a computer, database accessible by the computer and having stored thereon historical and real time data relating to a financial asset, and software executing on the computer for generating and displaying market analysis. The market analysis may, but not necessarily, include historical and real time data, a measure of liquidity and volatility of a financial asset, a measure of a financial asset's historical performance, an analysis of a financial

asset's return in relation to its risk, and computed correlation coefficients and analysis of relationships between a financial asset and its market or market sectors.

RESEARCH GAP: Business planning with real-time market research and financial projection based on AI, whereas the referenced patents focus only on financial planning or market analysis separately is the uniqueness of this innovation.

None of the prior art indicate above either alone or in combination with one another disclose what the present invention has disclosed. This invention relates to Automated AI-Powered Business Plan Generator system with Real-Time Market Research and Financial Projection Capabilities.

10 **SUMMARY OF THE INVENTION**

This summary is provided to introduce a selection of concepts, in a simplified format, that are further described in the detailed description of the invention.

This summary is neither intended to identify key or essential inventive concepts of the invention and nor is it intended for determining the scope of the invention.

15 To further clarify advantages and features of the present invention, a more particular description of the invention will be rendered by reference to specific embodiments thereof, which is illustrated in the appended drawings. It is appreciated that these drawings depict only typical embodiments of the invention and are therefore not to be considered limiting of its scope. The invention will be described and explained with additional specificity and detail with the
20 accompanying drawings.

The Automated AI-Powered Business Plan Generator with Real-Time Market Research and Financial Projection Capabilities is a cutting-edge system designed to revolutionize business

planning by integrating artificial intelligence with real-time data analysis. This innovation is structured around two key nodes: AI-Based Business Plan Generation & Market Research Node (AIBPGMR Node) and Real-Time Financial Projection & Analysis Node (RTFPA Node). These nodes work in synchronization to gather market insights, process financial data, and generate strategic business plans with minimal human intervention. The AIBPGMR Node is responsible for market research and business plan generation, incorporating components such as the NVIDIA Jetson Orin Nano, 128GB MicroSD Card, SX1278 RF Module, 512GB External SSD, Camera Module, and Power Supply. At the core of this node, the processing unit collects and analyzes large volumes of real-time market data, including industry trends, competitor insights, and economic indicators. The Camera Module facilitates document scanning and visual data collection, while the SX1278 RF Module enables secure wireless communication between the nodes. The External SSD stores extensive datasets and pre-trained AI models for efficient market assessment. With these capabilities, the AIBPGMR Node dynamically adapts to evolving market conditions, ensuring that business plans are generated based on up-to-date information.

15 BRIEF DESCRIPTION OF THE DRAWINGS

The illustrated embodiments of the subject matter will be understood by reference to the drawings, wherein like parts are designated by like numerals throughout. The following description is intended only by way of example, and simply illustrates certain selected embodiments of devices, systems, and methods that are consistent with the subject matter as claimed herein, wherein:

FIGURE 1: AIBPGMR Node

FIGURE 2: RTFPA Node

The figures depict embodiments of the present subject matter for the purposes of illustration only. A person skilled in the art will easily recognize from the following description that alternative embodiments of the structures and methods illustrated herein may be employed without departing from the principles of the disclosure described herein.

5 DETAILED DESCRIPTION OF THE INVENTION

The detailed description of various exemplary embodiments of the disclosure is described herein with reference to the accompanying drawings. It should be noted that the embodiments are described herein in such details as to clearly communicate the disclosure. However, the amount of details provided herein is not intended to limit the anticipated variations of embodiments; on
10 the contrary, the intention is to cover all modifications, equivalents, and alternatives falling within the scope of the present disclosure as defined by the appended claims.

It is also to be understood that various arrangements may be devised that, although not explicitly described or shown herein, embody the principles of the present disclosure. Moreover, all statements herein reciting principles, aspects, and embodiments of the present disclosure, as
15 well as specific examples, are intended to encompass equivalents thereof.

The terminology used herein is for the purpose of describing particular embodiments only and is not intended to be limiting of example embodiments. As used herein, the singular forms “a,” “an” and “the” are intended to include the plural forms as well, unless the context clearly indicates otherwise. It will be further understood that the terms “comprises,” “comprising,”
20 “includes” and/or “including,” when used herein, specify the presence of stated features, integers, steps, operations, elements and/or components, but do not preclude the presence or

addition of one or more other features, integers, steps, operations, elements, components and/or groups thereof.

It should also be noted that in some alternative implementations, the functions/acts noted may occur out of the order noted in the figures. For example, two figures shown in succession may, in fact, be executed concurrently or may sometimes be executed in the reverse order, depending upon the functionality/acts involved.

In addition, the descriptions of "first", "second", "third", and the like in the present invention are used for the purpose of description only, and are not to be construed as indicating or implying their relative importance or implicitly indicating the number of technical features indicated. Thus, features defining "first" and "second" may include at least one of the features, either explicitly or implicitly.

Unless otherwise defined, all terms (including technical and scientific terms) used herein have the same meaning as commonly understood by one of ordinary skill in the art to which example embodiments belong. It will be further understood that terms, e.g., those defined in commonly used dictionaries, should be interpreted as having a meaning that is consistent with their meaning in the context of the relevant art and will not be interpreted in an idealized or overly formal sense unless expressly so defined herein.

The Automated AI-Powered Business Plan Generator with Real-Time Market Research and Financial Projection Capabilities is a cutting-edge system designed to revolutionize business planning by integrating artificial intelligence with real-time data analysis. This innovation is structured around two key nodes: AI-Based Business Plan Generation & Market Research Node (AIBPGMR Node) and Real-Time Financial Projection & Analysis Node (RTFPA Node). These

nodes work in synchronization to gather market insights, process financial data, and generate strategic business plans with minimal human intervention. The AIBPGMR Node is responsible for market research and business plan generation, incorporating components such as the NVIDIA Jetson Orin Nano, 128GB MicroSD Card, SX1278 RF Module, 512GB External SSD, 5 Camera Module, and Power Supply. At the core of this node, the processing unit collects and analyzes large volumes of real-time market data, including industry trends, competitor insights, and economic indicators. The Camera Module facilitates document scanning and visual data collection, while the SX1278 RF Module enables secure wireless communication between the nodes. The External SSD stores extensive datasets and pre-trained AI models for efficient 10 market assessment. With these capabilities, the AIBPGMR Node dynamically adapts to evolving market conditions, ensuring that business plans are generated based on up-to-date information.

The RTFPA Node focuses on real-time financial projection and analysis, incorporating the Raspberry Pi 5, 128GB MicroSD Card, SX1278 RF Module, High-Resolution TFT Display, 15 USB Camera, and Power Supply. This node processes live financial data, evaluating revenue models, cost structures, and investment strategies to generate accurate financial forecasts. The USB Camera allows for document digitization, enabling users to input financial records seamlessly. The SX1278 RF Module facilitates data exchange with the AIBPGMR Node, ensuring that financial insights are aligned with business planning recommendations. The High- 20 Resolution TFT Display serves as an interactive interface, providing users with visualized financial trends, risk assessments, and performance predictions in an intuitive manner. The system operates through a seamless workflow: the AIBPGMR Node gathers real-time market intelligence, processes the data using AI algorithms, and generates a preliminary business plan.

This information is then transmitted via the SX1278 RF Module to the RTFPA Node, which evaluates the financial viability of the proposed business strategies. The processed insights are displayed on the High-Resolution TFT Display, allowing users to review projections and adjust their business approach accordingly. The entire system functions autonomously, reducing the need for manual research and financial analysis while ensuring precision and efficiency in business planning. By integrating advanced AI-driven analysis with real-time financial projection, this innovation eliminates traditional inefficiencies in business planning, providing a robust and automated approach for startups, entrepreneurs, and enterprises to make data-driven decisions.

10 **BEST METHOD OF WORKING**

An Automated AI-Powered Business Plan Generator system with Real-Time Market Research and Financial Projection Capabilities comprises of Camera Module (11), 512GB External SSD (12), 128GB MicroSD Card (13), SX1278 RF Module (14), NVIDIA Jetson Orin Nano (15), Power Supply (16), USB Camera (51), SX1278 RF Module (52), 128GB MicroSD Card (53), High-Resolution TFT Display (54), Raspberry Pi 5 (55), Power Supply (56).

The AI-Based Business Plan Generation & Market Research Node (AIBPGMR Node), equipped with an NVIDIA Jetson Orin Nano, 128GB MicroSD Card, SX1278 RF Module, 512GB External SSD, Camera Module, and Power Supply, enables real-time market data collection, analysis, and business strategy formulation, enhancing efficiency in business planning and decision-making.

The Real-Time Financial Projection & Analysis Node (RTFPA Node), incorporating a Raspberry Pi 5, 128GB MicroSD Card, SX1278 RF Module, High-Resolution TFT Display, USB Camera, and Power Supply, extends functionality by providing real-time financial

assessments, risk evaluations, and profitability forecasts, ensuring dynamic and data-driven financial planning.

The SX1278 RF Module, integrated within both the AIBPGMR Node and RTFPA Node, enables secure and seamless wireless data exchange between market analysis and financial
5 projection modules, ensuring synchronized and accurate business strategy development.

The 512GB External SSD, included in the AIBPGMR Node, allows high-speed storage and retrieval of extensive market research data, AI-driven insights, and business analytics, ensuring uninterrupted and efficient business plan generation.

The High-Resolution TFT Display, deployed in the RTFPA Node, provides a user-friendly
10 visual interface for real-time financial projections, investment risk analysis, and profitability assessments, enhancing accessibility and decision-making for users.

The USB Camera, integrated into the RTFPA Node, facilitates real-time document scanning and financial record digitization, enabling seamless data input for AI-driven financial forecasting and business planning.

15 **ADVANTAGES OF THE INVENTION**

1. The AI-Based Business Plan Generation & Market Research Node (AIBPGMR Node), powered by advanced processing capabilities, autonomously gathers and analyzes real-time market data to create precise and data-driven business plans.
2. The Real-Time Financial Projection & Analysis Node (RTFPA Node), equipped with a
20 high-resolution TFT display, provides real-time financial insights, risk assessments, and profitability forecasts for informed decision-making.
3. The SX1278 RF Module ensures seamless and secure wireless communication between nodes, enabling synchronized business plan generation and financial analysis.

4. The 512GB External SSD in the AIBPGMR Node allows efficient storage and retrieval of extensive market research data, ensuring comprehensive business strategy formulation.
5. The USB Camera facilitates document scanning and data input, enabling real-time integration of financial records and market insights into the automated planning system.
- 5 6. The High-Resolution TFT Display in the RTFPA Node provides an interactive interface for users to visualize financial projections, investment strategies, and market trends dynamically.

We Claim:

1. An Automated AI-Powered Business Plan Generator system with Real-Time Market Research and Financial Projection Capabilities comprises of Camera Module (11), 512GB External SSD (12), 128GB MicroSD Card (13), SX1278 RF Module (14), NVIDIA Jetson Orin Nano (15), Power Supply (16), USB Camera (51), SX1278 RF Module (52), 128GB MicroSD Card (53), High-Resolution TFT Display (54), Raspberry Pi 5 (55), Power Supply (56).
2. The system as claimed in claim 1, wherein the AI-Based Business Plan Generation & Market Research Node (AIBPGMR Node), equipped with an NVIDIA Jetson Orin Nano, 128GB MicroSD Card, SX1278 RF Module, 512GB External SSD, Camera Module, and Power Supply, enables real-time market data collection, analysis, and business strategy formulation, enhancing efficiency in business planning and decision-making.
3. The system as claimed in claim 1, wherein the Real-Time Financial Projection & Analysis Node (RTFPA Node), incorporating a Raspberry Pi 5, 128GB MicroSD Card, SX1278 RF Module, High-Resolution TFT Display, USB Camera, and Power Supply, extends functionality by providing real-time financial assessments, risk evaluations, and profitability forecasts, ensuring dynamic and data-driven financial planning.
4. The system as claimed in claim 1, wherein the SX1278 RF Module, integrated within both the AIBPGMR Node and RTFPA Node, enables secure and seamless wireless data exchange between market analysis and financial projection modules, ensuring synchronized and accurate business strategy development.
5. The system as claimed in claim 1, wherein the 512GB External SSD, included in the AIBPGMR Node, allows high-speed storage and retrieval of extensive market research data,

AI-driven insights, and business analytics, ensuring uninterrupted and efficient business plan generation.

6. The system as claimed in claim 1, wherein the High-Resolution TFT Display, deployed in the RTFPA Node, provides a user-friendly visual interface for real-time financial projections, investment risk analysis, and profitability assessments, enhancing accessibility and decision-making for users.
7. The system as claimed in claim 1, wherein the USB Camera, integrated into the RTFPA Node, facilitates real-time document scanning and financial record digitization, enabling seamless data input for AI-driven financial forecasting and business planning.

10 **Dated this March 25, 2025**



(Ashish Sharma)

Authorized Agent for the Applicant

Indian Patent Agent Regn No. IN/PA-3021

15

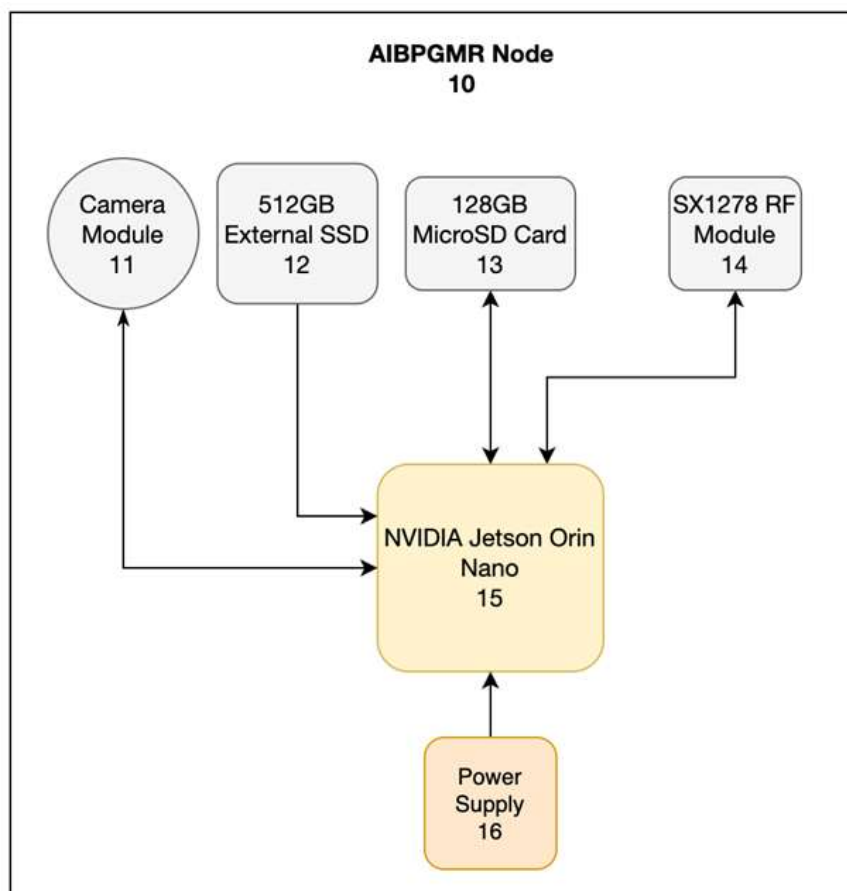

FIGURE 1

5

(Ashish Sharma)

Authorized Agent for the Applicant

Indian Patent Agent Regn No. IN/PA-3021

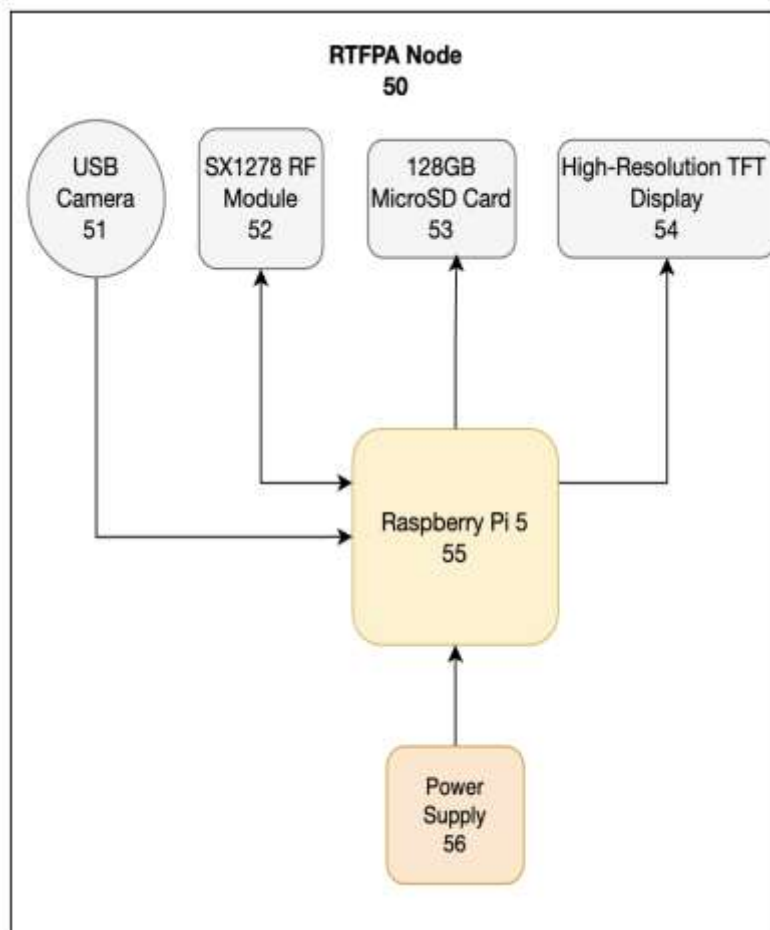

FIGURE 2

5

(Ashish Sharma)

Authorized Agent for the Applicant

Indian Patent Agent Regn No. IN/PA-3021

ABSTRACT

AN AUTOMATED AI-POWERED BUSINESS PLAN GENERATOR SYSTEM WITH REAL-TIME MARKET RESEARCH AND FINANCIAL PROJECTION

CAPABILITIES

- 5 An Automated AI-Powered Business Plan Generator system with Real-Time Market Research and Financial Projection Capabilities comprises of Camera Module (11), 512GB External SSD (12), 128GB MicroSD Card (13), SX1278 RF Module (14), NVIDIA Jetson Orin Nano (15), Power Supply (16), USB Camera (51), SX1278 RF Module (52), 128GB MicroSD Card (53), High-Resolution TFT Display (54), Raspberry Pi 5 (55), Power Supply (56).
- 10 The AI-Based Business Plan Generation & Market Research Node (AIBPGMR Node), equipped with an NVIDIA Jetson Orin Nano, 128GB MicroSD Card, SX1278 RF Module, 512GB External SSD, Camera Module, and Power Supply, enables real-time market data collection, analysis, and business strategy formulation, enhancing efficiency in business planning and decision-making.

15