



- (51) International Patent Classification:  
*B29D 11/00* (2006.01)
- (21) International Application Number:  
PCT/US2015/066008
- (22) International Filing Date:  
16 December 2015 (16.12.2015)
- (25) Filing Language: English
- (26) Publication Language: English
- (30) Priority Data:  
62/092,907 17 December 2014 (17.12.2014) US
- (71) Applicant (for all designated States except US): **NOVARTIS AG** [CH/CH]; Lichtstrasse 35, 4056 Basel (CH).
- (72) Inventors; and
- (71) Applicants (for US only): **LIU, Alice Weimin** [US/US]; c/o Alcon Research, Ltd., 11460 Johns Creek Parkway, Johns Creek, Georgia 30097 (US). **DIETRICH, Burkhard** [DE/DE]; c/o CIBA Vision GmbH, Postfach 4, 63868 Grosswallstadt (DE).
- (74) Agent: **HU, Sheng-Hsin**; Alcon Research, Ltd., Patent Department, 11460 Johns Creek Parkway, Johns Creek, Georgia 30097 (US).

(81) Designated States (unless otherwise indicated, for every kind of national protection available): AE, AG, AL, AM, AO, AT, AU, AZ, BA, BB, BG, BH, BN, BR, BW, BY, BZ, CA, CH, CL, CN, CO, CR, CU, CZ, DE, DK, DM, DO, DZ, EC, EE, EG, ES, FI, GB, GD, GE, GH, GM, GT, HN, HR, HU, ID, IL, IN, IR, IS, JP, KE, KG, KN, KP, KR, KZ, LA, LC, LK, LR, LS, LU, LY, MA, MD, ME, MG, MK, MN, MW, MX, MY, MZ, NA, NG, NI, NO, NZ, OM, PA, PE, PG, PH, PL, PT, QA, RO, RS, RU, RW, SA, SC, SD, SE, SG, SK, SL, SM, ST, SV, SY, TH, TJ, TM, TN, TR, TT, TZ, UA, UG, US, UZ, VC, VN, ZA, ZM, ZW.

(84) Designated States (unless otherwise indicated, for every kind of regional protection available): ARIPO (BW, GH, GM, KE, LR, LS, MW, MZ, NA, RW, SD, SL, ST, SZ, TZ, UG, ZM, ZW), Eurasian (AM, AZ, BY, KG, KZ, RU, TJ, TM), European (AL, AT, BE, BG, CH, CY, CZ, DE, DK, EE, ES, FI, FR, GB, GR, HR, HU, IE, IS, IT, LT, LU, LV, MC, MK, MT, NL, NO, PL, PT, RO, RS, SE, SI, SK, SM, TR), OAPI (BF, BJ, CF, CG, CI, CM, GA, GN, GQ, GW, KM, ML, MR, NE, SN, TD, TG).

**Declarations under Rule 4.17:**

- as to applicant's entitlement to apply for and be granted a patent (Rule 4.17(ii))
- as to the applicant's entitlement to claim the priority of the earlier application (Rule 4.17(iii))

[Continued on next page]

(54) Title: REUSABLE LENS MOLDS AND METHODS OF USE THEREOF

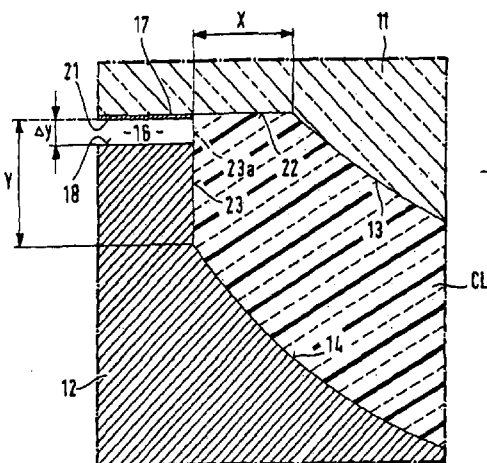

**Fig. 2**

(57) Abstract: The present invention general related to a method and a reusable mold for making a contact lens, comprising a first mold half having a first mold surface in contact with a silicone containing lens forming composition and a second mold half having a second mold surface in contact with the lens forming composition. The first mold half and the second mold half are configured to receive each other such that a cavity is formed between the first mold surface and the second mold surface, wherein the cavity defines the shape of a contact lens to be molded. The lens forming composition is polymerizable and/or crosslinkable by a UV radiation, wherein at least one of the mold halves is made from an oxide glass material having a UV transmission cut-off wavelength no less than 390 nm and a specific gravity higher than 3.5.

WO 2016/100457 A1

**Published:**

— *with international search report (Art. 21(3))*

## REUSABLE LENS MOLDS AND METHODS OF USE THEREOF

## BACKGROUND

A great effort has been made to develop technologies for cast molding of hydrogel contact lenses with high precision, fidelity and reproducibility and at low cost. One of such manufacturing technologies is the so-called Lightstream Technology™ (Alcon) involving reusable molds and curing a lens-forming composition under a spatial limitation of actinic radiation (U.S. Patent Nos. 5,508,317, 5,583,163, 5,789,464, 5,849,810, and 8,163,206), which are incorporated by reference in their entireties. The Lightstream Technology™ involves (1) a lens-forming composition, (2) reusable molds produced in high precision, and (3) curing under a spatial limitation of actinic radiation (e.g., UV/Visible light). Lenses produced according to the Lightstream Technology™ can have high consistency and high fidelity to the original lens design, because of use of reusable, high precision molds. In addition, contact lenses with high quality can be produced at relatively lower cost due to the short curing time and a high production yield.

Modern high-volume mass production process for medical devices like contact lenses utilizes re-usable molds in each production cycles. The conventional re-usable contact lens mold consists of a quartz convex base curve and a glass concave front curve. The base curve mold is composed of individually ground and polished quartz, while the front curve mold is composed of high precision press mold and polished glass. However, hydrogel contact lens production in curing under a spatial limitation of actinic radiation with Lightstream Technology™ may produce flash along lens edge due to lens forming material left in gap between base curve mold and front curve during curing under a spatial limitation of actinic radiation. Furthermore, when manufacturing UV absorbing contact lenses in the Lightstream technology, the lens edge quality issues (flash) become more severe than when manufacturing non-UV absorbing contact lenses.

Therefore, there is a need for new reusable molds for front curve mold that can produce lens with clean cut lens edge (no flash).

## SUMMARY OF THE INVENTION

The invention, in one respect, relates to a reusable mold for making a contact lens, comprising a first mold half having a first mold surface in contact with a silicone containing lens forming composition and a second mold half having a second mold surface in contact with the lens forming composition, wherein the first mold half and the second mold half are configured to receive each other such that a cavity is formed between the first mold surface

and the second mold surface, wherein the cavity defines the shape of a contact lens to be molded, wherein the lens forming composition is polymerizable and/or crosslinkable by an actinic radiation, wherein at least one of the mold halves is made from an oxide glass material having a UV transmission cut-off wavelength no less than 390 nm and a specific gravity higher than 3.5.

The invention, in another respect, relates to a method for producing a contact lens, comprising: the steps of:

(1) providing a contact lens mold, wherein the mold comprising a first mold half having a first mold surface and a second mold half having a second mold surface, wherein the first mold half and the second mold half are configured to receive each other such that a cavity is formed between the first mold surface and the second mold surface, wherein the cavity defines the shape of a contact lens to be molded, wherein at least one of the mold halves is made from an oxide glass material having a UV transmission cut-off wavelength no less than 390 nm and a specific gravity higher than 3.5, (2) introducing a lens-forming composition into the cavity formed by the first and second molding surfaces, material, wherein the lens-forming material is crosslinkable and/or polymerizable by actinic radiation; (3) crosslinking/polymerizing the lens-forming material in the mold to form a lens having a polymer matrix; (4) opening the mold and removing the formed contact lens from the mold, wherein the formed contact lens has a clean lens edge without flash.

#### BRIEF DESCRIPTION OF THE DRAWINGS

- Fig. 1 shows a section through an exemplary embodiment of a casting mold according to the invention in the closed position;
- Fig. 2 is a detail, indicated by II in Fig. 1, on a greatly enlarged scale.

#### DETAILED DESCRIPTION OF EMBODIMENTS OF THE INVENTION

Unless defined otherwise, all technical and scientific terms used herein have the same meaning as commonly understood by one of ordinary skill in the art to which this invention belongs. Generally, the nomenclature used herein and the laboratory procedures are well known and commonly employed in the art. Conventional methods are used for these procedures, such as those provided in the art and various general references. Where a term is provided in the singular, the inventors also contemplate the plural of that term. The nomenclature used herein and the laboratory procedures described below are those well-known and commonly employed in the art. As employed throughout the disclosure, the

following terms, unless otherwise indicated, shall be understood to have the following meanings.

“Oxide glass” refers to glass comprises oxide selected from the group consisting of Aluminum oxide, Antimony trioxide, Arsenic trioxide, Barium oxide, Bismuth(III) oxide, Boron trioxide, Calcium oxide, Cerium(III) oxide, Chromium(III) oxide, Gadolinium oxide, Germanium oxide, Iron(III) oxide, Lanthanum oxide, Lead(II) oxide, Lithium oxide, Magnesium oxide, Niobium pentoxide, Phosphorus pentoxide, Potassium oxide, Silicon dioxide, Sodium oxide, Strontium oxide, Sulfur dioxide, Tin dioxide, Titanium dioxide, Zinc oxide, Zirconium dioxide, Tellurium oxide, yttrium oxide and combination therefore.

“Quartz” refers to the second most abundant mineral in the Earth's continental crust, after feldspar. It is made up of a continuous framework of  $\text{SiO}_4$  silicon–oxygen tetrahedra, with each oxygen being shared between two tetrahedra, giving an overall formula  $\text{SiO}_2$ .

*“UV absorbing glasses” refer to glasses absorbing ultraviolet (UV) light which is electromagnetic radiation with a wavelength shorter than that of visible light, but longer than X-rays, thus wavelength is in the range between 400 nm and 10 nm. According to the present patent application, specifically, UV absorbing glasses refer to have UV cut –off wave length no less than 390 nm (defined as % transmission is no larger than 1%)*

*“Flash” refers to excess material attached to a molded lens edge which must usually be mechanically removed. This is typically caused by curing the material between the two surfaces of a mold. For example, flash forms from lens forming material left in gap between base curve mold and front curve during curing under a spatial limitation of actinic radiation.*

“An optical quality surface” refers to a glass surface has a surface roughness less than 30 nm, preferably less than 20 nm, most preferably less than 10 nm.

"About" as used herein means that a number referred to as "about" comprises the recited number plus or minus 1-10% of that recited number.

“Optional” or “optionally” means that the subsequently described event or circumstance can or cannot occur, and that the description includes instances where the event or circumstance occurs and instances where it does not.

An “ophthalmic lens” refers to a contact lens and/or an intraocular lens. A “contact lens” refers to a structure that can be placed on or within a wearer's eye. A contact lens can correct, improve, or alter a user's eyesight, but that need not be the case. A “silicone hydrogel contact lens” refers to a contact lens comprising a silicone hydrogel material.

As used in this application, the term “hydrogel” or “hydrogel material” refers to a crosslinked polymeric material which is not water-soluble and can contains at least 10% by weight of water within its polymer matrix when fully hydrated.

A “silicone hydrogel” refers to a hydrogel containing silicone. A silicone hydrogel typically is obtained by copolymerization of a polymerizable composition comprising at least

one silicone-containing vinylic monomer or at least one silicone-containing vinylic macromer or at least one silicone-containing prepolymer having ethylenically unsaturated groups.

A "vinylic monomer" refers to a compound that has one sole ethylenically-unsaturated group.

The term "olefinically unsaturated group" or "ethylenically unsaturated group" is employed herein in a broad sense and is intended to encompass any groups containing at least one  $>C=C<$  group.

A "UV-absorbing vinylic monomer" refers to a compound comprising an ethylenically-unsaturated group and a UV-absorbing moiety which can absorb or screen out UV radiation in the range from 200 nm to 400 nm as understood by a person skilled in the art.

A "spatial limitation of actinic radiation" refers to an act or process in which energy radiation in the form of rays is directed by, for example, a mask or screen or combinations thereof, to impinge, in a spatially restricted manner, onto an area having a well-defined peripheral boundary. A spatial limitation of UV radiation is obtained by using a mask or screen having a radiation (e.g., UV and/or visible light) permeable region, a radiation (e.g., UV and/or visible light) impermeable region surrounding the radiation-permeable region, and a projection contour which is the boundary between the radiation-impermeable and radiation-permeable regions, as schematically illustrated in the drawings of U.S. Patent Nos. 6,800,225 (Figs. 1-11), and 6,627,124 (Figs. 1-9), 7,384,590 (Figs. 1-6), and 7,387,759 (Figs. 1-6), all of which are incorporated by reference in their entireties. The mask or screen allows to spatially project a beam of radiation (e.g., UV radiation and/or visible radiation) having a cross-sectional profile defined by the projection contour of the mask or screen. The projected beam of radiation (e.g., UV radiation and/or visible radiation) limits radiation impinging on a lens formulation located in the path of the projected beam from the first molding surface to the second molding surface of a mold. The resultant contact lens comprises an anterior surface defined by the first molding surface, an opposite posterior surface defined by the second molding surface, and a lens edge defined by the sectional profile of the projected UV and/or visible beam (i.e., a spatial limitation of radiation). The radiation used for the crosslinking is radiation energy, especially UV radiation (and/or visible radiation), gamma radiation, electron radiation or thermal radiation, the radiation energy preferably being in the form of a substantially parallel beam in order on the one hand to achieve good restriction and on the other hand efficient use of the energy.

A "lens-forming material" refers to a material which can be polymerized and/or crosslinked by actinic radiation to form a contact lens.

"Actinic radiation" refers to radiation of a suitable form of energy. Examples of actinic radiation includes without limitation light radiation (e.g., UV radiation), gamma radiation, electron radiation, X-ray irradiation, microwave irradiation, thermal radiation and the like.

“UVA” refers to radiation occurring at wavelengths between 316 and 380 nanometers; “UVB” refers to radiation occurring between 280 and 315 nanometers; “Violet” refers to radiation occurring at wavelengths between 381 and 440 nanometers.

“UVA transmittance” (or “UVA %T”), “UVB transmittance” or “UVB %T”, and “average violet-transmittance” or “Violet %T” are calculated by the following formula:

$$\text{UVA \%T} = \frac{\text{Average \% Transmission between 316 nm and 380 nm}}{\text{Luminescence \%T}}$$

$$\text{UVB \%T} = \frac{\text{Average \% Transmission between 280 nm and 315 nm}}{\text{Luminescence \%T}}$$

$$\text{Violet \%T} = \text{Average \% Transmission between 381 nm and 440 nm}$$

in which Luminescence %T is defined according to ISO 18369-3 (section 4.6.1.2)

“UV-absorbing silicone hydrogel contact lenses” refers silicone hydrogel contact lenses which have an UVB transmittance of about 10% or less between 280 and 315 nanometers, an UVA transmittance of about 30% or less between 316 and 380 nanometers, optionally (but preferably) an average violet transmittance of about 70% or less between 381 nm and 440 nm. UV-absorbing silicone hydrogel contact lenses protect eyes to some extent from damages caused by UV radiation and potentially by high energy violet light (HEVL).

Further aspects and advantages of the process according to the invention and of the device according to the invention will be seen from the description that follows, in conjunction with the drawings.

The device shown in fig. 1 is designed for the manufacture of contact lenses from a liquid starting material which may be polymerized or crosslinked by UV radiation. It comprises a mold 1 and an energy source 2a, here a UV light source, as well as means 2b for directing the energy provided by the energy source 2a to the mold in the form of an essentially parallel beam. Of course, the energy source 2a and means 2b can also be combined to form a single unit.

The mold consists of two mold halves 11 and 12, each having a curved mold surface 13 and 14 which together define a mold cavity 15, which in turn determines the shape of the contact lens to be manufactured. The mold surface 13 of the upper mold half 11 in the drawing is convex and determines the rear and base surface of the contact lens with the connected edge area; this mold half is normally called the father mold half. Conversely, the mold surface 14 of the other mold half, which is correspondingly called the mother mold half, is concave and determines the front face of the contact lens to be manufactured, likewise with the connected edge area.

The mold cavity 15 is not completely and tightly closed, but in the embodiment illustrated is open around its peripheral edge which defines the edge of the contact lens to be manufactured, and is linked to a relatively narrow annular gap 16. The annular gap 16 is limited or formed by a flat mold wall 17 and 18 on each of the father mold half 11 and the mother mold half 12. In order to prevent complete closure of the mold, spacers, for example in the form of several bolts 19a or 19b, are provided on the mother mold 12, and these interact with a collar or flange 20 of the father mold 11 and keep the two mold halves at such a distance apart that the said annular gap 16 results. As is indicated symbolically in fig. 1 by the right-hand spacer bolt 19b with a thread, the spacers may also be of adjustable or spring-action formation. In this way, the two mold halves 11, 12 can be moved towards one another during the crosslinking process to balance out leakage, by adjusting the spacers (indicated symbolically by the arrow 19c showing the direction of rotation) or against a spring action. Of course, the mold can be opened and closed in the usual manner, for example by means of a closure unit which is indicated here only by the arrow symbol 1a. Adjustment of the gap between the two mold halves 11, 12 to balance out leakage, may also be effected e.g. using this external closure unit.

It is also conceivable that, instead of the continuous annular gap 16 and the spacers 19a and 19b, a series of segmentous gaps may be provided, the intermediate areas between the individual segment gaps taking over the function of the spacers. Of course, other configurations of mold halves are also conceivable.

On the mold wall 17 in the area of the annular gap 16, there is a mask 21 which is impermeable to the energy form employed, here this is UV light, (or a mask which at least has poor permeability compared with the permeability of the mold), and this mask extends right to the mold cavity 15, and with the exception of the same, screens all the other parts, hollow spaces or areas of the mold 1 that are in contact with or may come into contact with the liquid, uncrosslinked, possibly excess material, from the radiated energy. Partial areas of the lens edge are therefore formed not by a limitation of the material by mold walls, but by a spatial limitation of the radiation or other forms of energy triggering polymerization or crosslinking.

In the case of UV light, the mask 21 may be preferably a chromium layer, that can be produced by processes known e.g. from photography or UV-lithography. The mask 21 does not necessary have to be fixed; it may also be, for example, removable or exchangeable.

FIG. 2 shows the arrangement of the mold 1 in the transition region between the mold cavity 15 and the annular channel 16 as an enlarged detail. The cavity 15 has here, by way of example, a shape that corresponds to the typical rim geometry of a so-called soft contact lens CL. The cavity rim, and thus the lens rim, is formed here by two wall faces 22 and 23 which are arranged at right angles to one another and are



arranged on the male and on the female mold halves 11 and 12 respectively. The width and the height of those two wall faces, and of the rim areas of the contact lens defined by them, are indicated by X and Y respectively. Obviously, the lens rim may in practice also be slightly rounded.

As can be seen clearly, the cylindrical wall face 23 of the female mold half 12 does not extend right up to the fiat wall face 22 and the wall face 17, lying seamlessly adjacent thereto, of the male mold half 11, but is lower by the amount  $\Delta y$ , so that the annular gap 16 already mentioned, between the wall face 17 and the wall face 18 of the two mold halves 11 and 12, is formed or remains open.

The mask 21 provided on the wall face 17 of the male mold half 11 in this example embodiment extends horizontally exactly up to the extension 23a of the wall face 23 of the female mold half 12. If the UV light, in the form of a parallel beam 3 causing the crosslinking, is incident at right angles to the wall face 22 and 17 and parallel to the cylindrical wall face 23, the space located at right angles below the mask 21 is in shadow and only the material located inside the cavity 15, that is inside the imaginary wall extension 23a, is crosslinked, resulting in a clean and burr-free lens rim which does not require any subsequent mechanical processing. If parallel energy radiation is used, therefore, disregarding the diffraction and scattering effects, which are usually negligible in practice, the contour of the mask 21 is transferred two-dimensionally parallel and (in this case) downwards into the rim area of the contact lens. Therefore, if the two mold halves 11 and 12 are separated from one another by the annular gap 16 of height  $\Delta y$ , the rim is formed towards the outside of the area resulting from that displacement by means of the spatial restriction of the energy radiation.

In general, the invention, in one respect, is directed a reusable mold for making a contact lens, comprising a first mold half having a first mold surface in contact with a silicone containing lens forming composition and a second mold half having a second mold surface in contact with the lens forming composition, wherein the first mold half and the second mold half are configured to receive each other such that a cavity is formed between the first mold surface and the second mold surface, wherein the cavity defines the shape of a contact lens to be molded, wherein the lens forming composition is polymerizable and/or crosslinkable by an actinic radiation, wherein at least one of the mold halves is made from an oxide glass material having a UV transmission cut-off wavelength no less than 390 nm and a specific gravity higher than 3.5.

Lightstream Technology™ (Alcon) involving reusable molds and curing a lens-forming composition under a spatial limitation of actinic radiation. According to the Lightstream Technology™, the impingement upon the material of the energy causing crosslinking is restricted spatially to the region of the mold cavity, so that substantially only the starting

material located in the mold cavity, that is to say the region of the contact lens, is crosslinked. Any excess starting material present is not polymerized or crosslinked. In that arrangement, partial areas of the contact lens edge are formed not by a mechanical limitation of the material by mold walls but by a spatial restriction of the impinging energy (usually UV or some other radiation) that triggers the polymerization or crosslinking. As a result of those two measures, contact between the two mold halves can in a preferred arrangement be avoided, so that they are not deformed and can accordingly be used again.

A reusable mold suitable for spatial limitation of radiation is used in the invention, the projected beam of radiation limits radiation (e.g., UV radiation) impinging on the pre-polymerization mixture of the lens-forming materials located in the path of the projected beam from the first molding surface to the second molding surface of the reusable mold. The resultant contact lens comprises an anterior surface defined by the first molding surface, an opposite posterior surface defined by the second molding surface, and a lens edge defined by the sectional profile of the projected radiation beam (i.e., a spatial limitation of radiation). Examples of reusable molds suitable for spatial limitation of radiation include without limitation those disclosed in U.S. Patent Nos. 6,627,124, 6,800,225, 7,384,590, and 7,387,759, which are incorporated by reference in their entireties.

According to the present invention, applying energy on one side, it is in principle possible for the mold half facing away from the energy source to be produced from any material which withstands the crosslinkable material or components thereof. However, potential reflections and scattering of curing light are to be expected, depending on the type of energetic radiation (such as wavelength of curing light), and these may possibly lead to undesired effects such as producing flash on the edge because the reflections and scattering of curing light will polymerizing the lens forming material in the gap area between two molds.

The invention is partly based on the discovery that a hydrogel contact lens can be made using Lightstream Technology™ with mold system having at least one of the mold halves is made from an oxide glass material having a UV transmission cut-off wavelength no less than 390 nm and a specific gravity higher than 3.5 enable to achieve a hydrogel contact lens having a clean lens edge without flash. It is believed that reduction of reflection and scattering of curing light by using a mold system having at least one of the mold halves is made from an oxide glass material which having a UV transmission cut-off wavelength no less than 390 nm and a specific gravity higher than 3.5. Therefore, lens forming material left in the gap between base curve mold and front curve under a spatial limitation of actinic radiation will not be cured, and the un-crosslinked lens forming material left in the gap between base curve mold and front curve under a spatial limitation of actinic radiation can

be washed away. As such, a hydrogel contact lens having a clean lens edge without flash can be produced.

According to the present invention, any UV absorbing glass can be used as a mold material provided the UV absorbing glass has a UV cut-off wave length no less than 390 nm (defined as % transmission is no larger than 1%).

Glasses absorb UV are caused by small defects in the composition such as Iron as well as intentional additions like  $\text{Na}_2\text{O}$ . The reason for this UV absorption has to do with the bonding of each glass type. Most commercial glasses are sodium-silicates. These glasses consist of a connected silica network, which is broken up by the alkali (sodium). The addition of sodium breaks the network creating non-bridging oxygens, which lowers the melting temperature as well as reducing the energy of electromagnetic radiation needed for absorption. In combination with small amounts of iron impurity, which leads to intense UV absorption bands, these non-bridging oxygens prevent the transmission of UV light.

Different glasses have different UV edges (the frequency of UV light that begins being absorbed). In essence, the more loosely the electrons are bound, usually because they are not involved in covalent bonding in the case of non-bridging oxygens, the less UV light is transmitted.

According to the present application, glasses formed with heavy metal (atomic weight >100) oxides comprising of an oxide formed from Tellurium (Te), Lead (Pb), Tantalum (Ta), Bismuth (Bi), Antimony (Sb), or combinations thereof are preferred UV absorbent glasses as long as they have high refractive index, high density and a UV light absorbing with cut-off wavelength no less than 390 nm. The heavy metal (atomic weight >100) oxides containing glasses show higher refractive index and higher UV transmission cut-off wavelength. The increase in refractive index and UV transmission cut-off wavelength are attributed to the generation of non bridging oxygen due to incorporation of heavy metal-O in the glass network. These glasses are also show high density with increase in heavy metal oxide content.

Commercially available UV absorbing glasses include: Sumita K-PSFn1, K-PSFn2, K-PSFn173, K-PSFn215, Schott P-SF67, P-SF68, Ohara L-BBH1, S-NPH 3, and Hoya E-FDS1 are identified. All UV absorbing glasses have index of refraction > 1.9 and denser with specific gravity SG > 3.5. The most preferred heavy metal (atomic weight >100) oxides glasses are Bismuth oxide glasses, for example, Ohara L-BBH1, Schott P-SF67, P-SF68, etc.

According to the present invention, the above commercially available UV absorbing glasses can be made into mold by precision press mold, if the glass having HK value below 350, then it can also be single point diamond turned (SPDT) or both depending on their glass transition temperature and Knoop Hardness (HK) hardness. Typically, commercially

available UV absorbing glasses having a glass transition temperature less than 600°C can be made into mold by precision press molding process, having a HK hardness less than 350 can be made into mold by SPDT process. For example, Ohara L-BBH1 not only can be precision press molded to produce front curve molds in production, they also can be machined (single point diamond turned) to produce optically smooth surface in lens prototyping. Traditionally, Lightstream™ prototype molds are none glass materials such as plastics for development speed, this introduces a risk due to limited processability and metrology information of the lens design. The UV absorbing glasses such as Ohara L-BBH1 have the potential of seamless transition from prototyping to production molds.

Table 1 summarizes a list of UV absorbing glasses offered by Sumita, Schott, Ohara, and Hoya. Some common characteristics of these glasses are:

Index of refraction is fairly large with  $n_d > 1.9$  in all cases.

Specific gravity (SG) is higher than traditional soda lime glasses  $SG > 3.5$

Tg and AT or press mold temperature are nominal.

CTE values are in the order of  $10^{-5}/K$  with exception of P-SF67, S-NPH 3, and E-FDS1 glasses have lower CTE of  $\sim 7 \times 10^{-6}/K$  (100 to 300°C).

L-BBH1 has the lowest HK of 330, while other grades have higher HK (Knoop hardness) values.

Table 1 UV absorbing glass property comparisons. UV cut-off wavelength defined as  $\%T \leq 1\%$ . Nikon glass is not considered as UV absorbing glass.

Table 1

Supplier	Grade	nd	SG	Tg(°C)	HK	cut-off (≤1%)
Sumita	K-PSFn1	1.906	4.15	498	444	392
Sumita	K-PSFn2	2.001	5.48	480	392	395
Sumita	K-PSFn173	2.147	7.03	406	371	408
Sumita	K-PSFn215	2.153	7.10	405	386	420
Schott	P-SF67	1.907	4.24	539	440	391
Schott	P-SF68	2.005	6.19	428	404	406
Schott	N-B270	1.523	2.55	533	542	295
Ohara	S-NPH3	1.959	3.59	671	450	400
Ohara	L-BBH1	2.102	6.57	350	330	421
Hoya	E-FDS1	1.923	3.94	660	460	390
Nikon	J-LASH17	2.000	4.69	681	605	380

According to the present invention, a lens-forming material refers to any material which can be polymerized and/or crosslinked by actinic radiation to form a contact lens. A preferred group of lens-forming materials are prepolymers which are water-soluble and/or meltable. It would be advantageous that a lens-forming material comprises primarily one or more prepolymers which are preferably in a substantially pure form (e.g., purified by ultrafiltration). For example, prefunctionalised PVA (polyvinyl alcohol) polymer used as lens forming material, as illustrated in U.S. Patent Nos. 5,508,317; 8,030,369 and U.S. patent application publication no. 2006/0251696, which are incorporated by reference in their entireties. A more preferred group of lens-forming materials is silicone-containing hydrogel. Generally silicone-containing hydrogel comprises at least one components selected from the group consisting of a silicone-containing vinylic monomer, a silicone-containing vinylic macromer, a silicone-containing prepolymer, a hydrophilic vinylic monomer, a hydrophobic vinylic monomer, a crosslinking agent, a free-radical initiator (photoinitiator or thermal initiator), a hydrophilic vinylic macromer/prepolymer, and combinations thereof, as well known to a person skilled in the art, as illustrated in U.S. Patent Nos. 5,760,100 and 8,480,227, which are incorporated by reference in their entireties. A still more preferred group of lens-forming materials is UV-absorbing silicone-containing hydrogel. Generally UV-absorbing silicone-containing hydrogel lens forming mixture comprises at least one hydrophilic vinylic monomer, at least one siloxane-containing vinylic monomer, at least one polysiloxane crosslinker (with two or more ethylenically-unsaturated groups), at least one UV-absorbing vinylic monomer that absorbs ultraviolet light and optionally (but preferably) high-energy violet light from 381 nm to 440 nm, at least one tinting agent, and at least one germanium-based Norrish Type I photoinitiator capable of initiating a free-radical polymerization under irradiation with a light source including a light in the region of about 380 to about 550 nm, and the UV-absorbing silicone-containing hydrogel lens forming mixture is irradiated in the mold with a light in a region of from 380 to 550 nm and crosslinking the lens-forming materials to form the UV-absorbing silicone hydrogel contact lens, as illustrated in co-pending case, U.S. Patent Application No. 61/884181, which is incorporated by reference in their entireties. Any suitable UV-absorbing vinylic monomers can be used in the preparation of a UV-absorbing polymer of the invention. A UV-absorbing vinylic monomer used in the invention comprises a benzophenone-moiety, preferably a benzotriazole-moiety. In a preferred embodiment, a UV-absorbing vinylic monomer used in the invention is a benzotriazole-containing UV/HEVL absorber that absorbs both ultraviolet light and high-energy violet light (HEVL), for example, 2-(2'-hydroxy-5'-methacryloxyethylphenyl)

benzotriazole (2-Propenoic acid, 2-methyl-, 2-[3-(2*H*-benzotriazol-2-yl)-4-hydroxyphenyl]ethyl ester, Norbloc). Any germanium-based Norrish Type I photoinitiators can be used in the UV-absorbing silicone-containing hydrogel lens forming mixture, so long as they are capable of initiating a free-radical polymerization under irradiation with a light source including a light in the region of about 380 to about 550 nm. Examples of germanium-based Norrish Type I photoinitiators are acylgermanium compounds described in US 7,605,190 (herein incorporated by reference in its entirety). For curing the UV-absorbing silicone-containing hydrogel lens forming mixture, light source can be any ones emitting light in the 380-550 nm range sufficient to activate germanium-based Norrish Type I photoinitiators. Blue-light sources are commercially available and include: the Palatray CU blue-light unit (available from Heraeus Kulzer, Inc., Irvine, Calif.), the Fusion F450 blue light system (available from TEAMCO, Richardson, Tex.), Dymax Blue Wave 200, LED light sources from Opsytec (385 nm, 395 nm, 405 nm, 435 nm, 445 nm, 460 nm), LED light sources from Hamamatsu (385 nm), and the GE 24" blue fluorescent lamp (available from General Electric Company, U.S.). A preferred blue-light source is the UV LED from Opsytec (those described above). The intensity of the light source is set to produce lenses of good quality given the light source and photoinitiator. The total intensity of the light source is preferably from about 10 to about 100 mW/cm<sup>2</sup>, preferably from about 20 to about 60 mW/cm<sup>2</sup> in the 380 nm to 550 nm region is more preferred. The crosslinking may be effected in any time period of about 40 minutes or less, preferably in a very short time (e.g. in  $\leq$  about 120 seconds, preferably in  $\leq$  about 80 seconds, more preferably in  $\leq$  50 about seconds, even more preferably in  $\leq$  about 30 seconds, and most preferably in 5 to 30 seconds).

The invention, in another respect, relates to a method for producing a contact lens, comprising: the steps of:

- (1) providing a contact lens mold, wherein the mold comprising a first mold half having a first mold and a second mold half having a second mold surface, wherein the first mold half and the second mold half are configured to receive each other such that a cavity is formed between the first mold surface and the second mold surface, wherein the cavity defines the shape of a contact lens to be molded, wherein at least one of the mold halves is made from an oxide glass material having a UV transmission cut-off wavelength no less than 390 nm and a specific gravity higher than 3.5,

- (2) introducing a lens-forming composition into the cavity formed by the first and second molding surfaces, material, wherein the lens-forming material is crosslinkable and/or polymerizable by actinic radiation;
- (3) crosslinking/polymerizing the lens-forming material in the mold to form a lens having a polymer matrix;
- (4) opening the mold and removing the formed contact lens from the mold, wherein the formed contact lens has a clean lens edge without flash.

The previous disclosure will enable one having ordinary skill in the art to practice the invention. Various modifications, variations, and combinations can be made to the various embodiment described herein. In order to better enable the reader to understand specific embodiments and the advantages thereof, reference to the following examples is suggested. It is intended that the specification and examples be considered as exemplary.

### Example 1

#### Preparation of CE-PDMS Macromer

In the first step,  $\alpha,\omega$ -bis(2-hydroxyethoxypropyl)-polydimethylsiloxane ( $M_n = 2000$ , Shin-Etsu, KF-6001a) is capped with isophorone diisocyanate (IPDI) by reacting 49.85 g of  $\alpha,\omega$ -bis(2-hydroxyethoxypropyl)-polydimethylsiloxane with 11.1 g IPDI in 150 g of dry methyl ethyl ketone (MEK) in the presence of 0.063g of dibutyltindilaurate (DBTDL). The reaction is kept for 4.5 h at 40° C, forming IPDI-PDMS-IPDI. In the second step, a mixture of 164.8 g of  $\alpha,\omega$ -bis(2-hydroxyethoxypropyl)-polydimethylsiloxane ( $M_n = 3000$ , Shin-Etsu, KF-6002) and 50 g of dry MEK are added dropwise to the IPDI-PDMS-IPDI solution to which has been added an additional 0.063 g of DBTDL. The reactor is held for 4.5 h at about 40° C, forming HO-PDMS-IPDI-PDMS-IPDI-PDMS-OH. MEK is then removed under reduced pressure. In the third step, the terminal hydroxyl-groups are capped with methacryloyloxyethyl groups in a third step by addition of 7.77 g of isocyanatoethylmethacrylate (IEM) and an additional 0.063 g of DBTDL, forming IEM-PDMS-IPDI-PDMS-IPDI-PDMS-IEM (i.e., CE-PDMS terminated with methacrylate groups).

#### Alternate Preparation of CE-PDMS Macromer with Terminal Methacrylate Groups

240.43 g of KF-6001 is added into a 1-L reactor equipped with stirring, thermometer, cryostat, dropping funnel, and nitrogen/vacuum inlet adapter, and then dried by application of high vacuum ( $2 \times 10^{-2}$  mBar). Then, under an atmosphere of dry nitrogen, 320 g of distilled MEK is then added into the reactor and the mixture is stirred thoroughly. 0.235 g of DBTDL is added to the reactor. After the reactor is warmed to 45°C, 45.86 g of IPDI are added through an addition funnel over 10 minutes to the reactor under moderate stirring. The reaction is kept for 2 hours at 60°C. 630 g of KF-6002 dissolved in 452 g of distilled MEK are then added and stirred until a homogeneous solution is formed. About 0.235 g of DBTDL is

added, and the reactor is held at about 55°C overnight under a blanket of dry nitrogen. The next day, MEK is removed by flash distillation. The reactor is cooled and 22.7 g of IEM are then charged to the reactor followed by about 0.235 g of DBTDL. After about 3 hours, an additional 3.3 g of IEM are added and the reaction is allowed to proceed overnight. The following day, the reaction mixture is cooled to about 18°C to obtain CE-PDMS macromer with terminal methacrylate groups.

### Example 2

#### Preparation of Formulations for Lens Fabrication (a pre-polymerization mixture of lens forming materials)

Lens formulations are prepared by mixing components listed in Table 2 below followed by heating at 40° C for 20 min.

Table 2

Lens Formulation	2
Carbazole violet	-
CuP tint (%)	0.1
DMPC (%)	0.76
LPEG2000 (%)	0.61
Norbloc (%)	1
CE PDMS (%)	
Tris acrylamide (%)	19.71
Darocur 1173 (%)	-
Ge-PI (%)	0.36
1-propanol (%)	23.82
DMA (%)	23.24

- L-PEG 2000: N-(carbonyl-methoxypolyethylene glycol-2000)-1,2-disteaoyl-sn-glycero-3-phosphoethanolamin, sodium salt;  
 CE-PDMS: chain-extended polydimethylsiloxane crosslinker prepared in Example 2;  
 DMA: N,N-dimethylacrylamide;  
 TRIS-Am: N-[tris(trimethylsiloxy)-silylpropyl]acrylamide;  
 WL-1: 2-hydroxy-5-methoxy-3-(5-(trifluoromethyl)-2H-benzo[d][1,2,3]triazol-2-yl)benzyl methacrylate;  
 Darocur 1173: 2-Hydroxy-2-methylpropiophenone  
 DMPC: 1,2-Dimyristoyl-sn-glycero-3-phosphocholine  
 Carbazole violet: pigment added to adjust final lens color  
 CuP tint: 5% copper phthalocyanine blue pigment dispersion in  
 TRIS acrylamide tris(trimethylsiloxy)silylpropylmethacrylate,



### Example 3

PAA-coating solution. A polyacrylic acid (PAA) coating solution is prepared by dissolving an amount of PAA (M.W.: 450kDa, from Lubrizol) in a given volume of 1-propanol (1-PrOH) to have a concentration of about 0.44% by weight and the pH is adjusted with formic acid to about 2.0.

Preparation of In-Package-Coating solution (IPC saline). Poly(AAm-co-AA)(90/10) partial sodium salt ( ~90% solid content, poly(AAm-co-AA) 90/10, Mw 200,000) is purchased from Polysciences, Inc. and used as received. Polyamidonamine epichlorohydrin (PAE) (Kymene, an azetidinium content of 0.46 assayed with NMR) is purchased from Ashland as an aqueous solution and used as received. IPC saline is prepared by dissolving about 0.07% w/w of poly(AAm-co-AA)(90/10) and about 0.15% of PAE (an initial azetidinium millimolar equivalents of about 8.8 millimole) in phosphate-buffered saline (PBS) (about 0.044 w/w%  $\text{NaH}_2\text{PO}_4 \cdot \text{H}_2\text{O}$ , about 0.388 w/w%  $\text{Na}_2\text{HPO}_4 \cdot 2\text{H}_2\text{O}$ , about 0.79 w/w% NaCl) and adjusting the pH to 7.2~7.4. Then the IPC saline is heat pre-treated for about 4 hours at about 70° C (heat pretreatment). During this heat pretreatment, poly(AAm-co-AA) and PAE are partially crosslinked to each other (i.e., not consuming all azetidinium groups of PAE) to form a water-soluble and thermally-crosslinkable hydrophilic polymeric material containing azetidinium groups within the branched polymer network in the IPC saline. After the heat pre-treatment, the IPC is cooled to room temperature then filtered using a 0.22micron PES membrane filter.

### Example 4

#### Lens Fabrication using Formulation 2.

Lenses are prepared by cast-molding from the lens formulation prepared above in two set of reusable mold. The first set for lens sample 2A uses quartz base curve mold half and glass front curve mold half and the second set for lens sample 2B uses quartz base curve mold half and LBHH-1 front curve mold half. Lens formulation 2 prepared in Example 2 are used for both lens samples 2A and 2B. Lens formulation 2 in molds is irradiated for 25 seconds using a 405 nm LED supplied by Opsytec for both lens samples 2A and 2B. The measured total intensity from 350 to 460 nm is about 25 mW/cm<sup>2</sup>. Cast-molded contact lenses are then extracted by dipping in the following series of baths: deionized (DI) water bath (about 56 seconds); 3 methyl ethyl ketone (MEK) baths (about 22, 78, 224 seconds respectively, (DI) water bath (about 56 seconds). After lens extraction, the lenses are in contact for 44 seconds with the PAA-coating solution prepared above to form a PAA coating on each lens, then equilibrated into water, and then placed into polypropylene shells containing 0.65 mL of IPC saline prepared above, and autoclaved for 45 minutes at 121° C.

The lens edge quality and curing conditions are given in Table 3 below.

Table 3

	2A	2B
Cure Lamp	405nm LED	405nm LED
Total Intensity (mW/cm <sup>2</sup> )	25	25
Cure Time (s)	25	25
Base Curve /Front Curve Mold	quartz /N-B270 glass	quartz /L-BBH1
Lens Edge Quality	Heavy flash, bad lens edge quality	No flash, great lens edge quality

What we claim is:

1. A reusable mold for making a contact lens, comprising a first mold half having a first mold surface in contact with a silicone containing lens forming composition and a second mold half having a second mold surface in contact with the lens forming composition, wherein the first mold half and the second mold half are configured to receive each other such that a cavity is formed between the first mold surface and the second mold surface, wherein the cavity defines the shape of a contact lens to be molded, wherein the lens forming composition is polymerizable and/or crosslinkable by an actinic radiation, wherein at least one of the mold halves is made from an oxide glass material having a UV transmission cut-off wavelength no less than 390 nm and a specific gravity higher than 3.5.
2. The reusable mold for making a contact lens according to claim 1, wherein the oxide glass material comprising of a heavy metal oxide formed from Tellurium (Te), Lead (Pb), Tantalum (Ta), Bismuth (Bi), Antimony (Sb), and combinations thereof.
3. The reusable mold for making a contact lens according to anyone of preceding claims, wherein the oxide glass material has a glass transition temperature less than 600°C.
4. The reusable mold for making a contact lens according to anyone of preceding claims, wherein the oxide glass material has a refraction index higher than 1.9.
5. The reusable mold for making a contact lens according to anyone of preceding claims, wherein oxide glass material having a UV transmission cut-off wavelength no less than 410 nm.
6. The reusable mold for making a contact lens according to anyone of preceding claims, wherein the oxide glass material has a specific gravity higher than 4.5.
7. The reusable mold for making a contact lens according to anyone of preceding claims, wherein the reusable mold is made by precision press molding.
8. The reusable mold for making a contact lens according to anyone of preceding claims, wherein the reusable mold is made by single point diamond turning.
9. A method for producing a contact lens, comprising: the steps of:
  - (1) providing a contact lens mold, wherein the mold comprising a first mold half having a first mold and a second mold half having a second mold surface, wherein the first mold half and the second mold half are configured to receive each other such that a cavity is formed between the first mold surface and the second mold surface, wherein the cavity defines the shape of a contact lens to be molded, wherein at least one of the mold halves is made from an oxide glass material having a UV transmission cut-off wavelength no less than 390 nm and a specific gravity higher than 3.5,

(2) introducing a lens-forming composition into the cavity formed by the first and second molding surfaces, material, wherein the lens-forming material is crosslinkable and/or polymerizable by actinic radiation;

(3) crosslinking/polymerizing the lens-forming material in the mold to form a lens having a polymer matrix;

(4) opening the mold and removing the formed contact lens from the mold, wherein the formed contact lens has a clean lens edge without flash.

10. The method for producing a contact lens according to claim 9, wherein the oxide glass material comprising of a heavy metal oxide formed from Tellurium (Te), Lead (Pb), Tantalum (Ta), Bismuth (Bi), Antimony (Sb), and combinations thereof.
11. The method for producing a contact lens according to anyone of claims 9 to 10, wherein the oxide glass material has a refraction index higher than 1.9.
12. The method for producing a contact lens according to anyone of claims 9 to 11, wherein oxide glass material having a UV transmission cut-off wavelength no less than 410 nm.
13. The method for producing a contact lens according to anyone of claims 9 to 12, wherein the reusable mold is made by precision press molding.
14. The method for producing a contact lens according to anyone of claims 9 to 13, wherein the reusable mold is made by single point diamond turning.

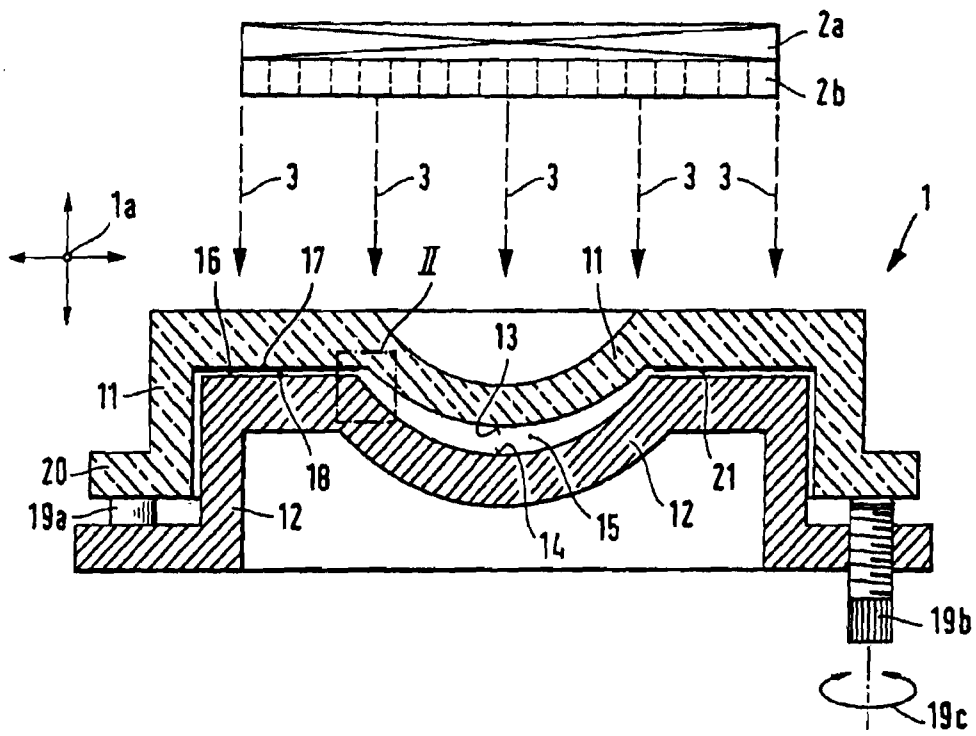

**Fig. 1**

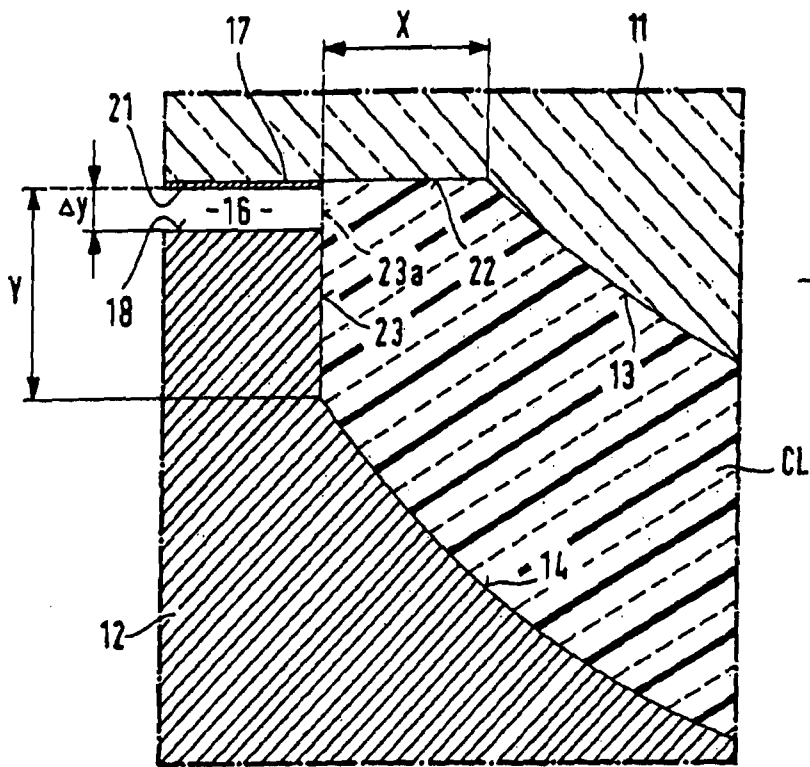

**Fig. 2**

# INTERNATIONAL SEARCH REPORT

International application No  
PCT/US2015/066008

**A. CLASSIFICATION OF SUBJECT MATTER**

INV. B29D11/00  
ADD.

According to International Patent Classification (IPC) or to both national classification and IPC

**B. FIELDS SEARCHED**

Minimum documentation searched (classification system followed by classification symbols)  
B29D

Documentation searched other than minimum documentation to the extent that such documents are included in the fields searched

Electronic data base consulted during the international search (name of data base and, where practicable, search terms used)

EPO-Internal, CHEM ABS Data, INSPEC, IBM-TDB, WPI Data

**C. DOCUMENTS CONSIDERED TO BE RELEVANT**

Category*	Citation of document, with indication, where appropriate, of the relevant passages	Relevant to claim No.
X	JP 2000 326347 A (MENICON COMPANY LIMITED) 28 November 2000 (2000-11-28) paragraphs [0001] - [0003] paragraphs [0025] - [0026] paragraphs [0045] - [0049] claims 1-7	1-14
A	----- US 2004/207105 A1 (ALTMANN GRIFFITH E [US]) 21 October 2004 (2004-10-21) paragraph [0002]; figures 1,2 paragraphs [0028] - [0033] claims 15, 22, 27, 28-31 ----- -/--	1-14

Further documents are listed in the continuation of Box C.

See patent family annex.

\* Special categories of cited documents :

"A" document defining the general state of the art which is not considered to be of particular relevance

"E" earlier application or patent but published on or after the international filing date

"L" document which may throw doubts on priority claim(s) or which is cited to establish the publication date of another citation or other special reason (as specified)

"O" document referring to an oral disclosure, use, exhibition or other means

"P" document published prior to the international filing date but later than the priority date claimed

"T" later document published after the international filing date or priority date and not in conflict with the application but cited to understand the principle or theory underlying the invention

"X" document of particular relevance; the claimed invention cannot be considered novel or cannot be considered to involve an inventive step when the document is taken alone

"Y" document of particular relevance; the claimed invention cannot be considered to involve an inventive step when the document is combined with one or more other such documents, such combination being obvious to a person skilled in the art

"&" document member of the same patent family

Date of the actual completion of the international search

26 February 2016

Date of mailing of the international search report

09/03/2016

Name and mailing address of the ISA/

European Patent Office, P.B. 5818 Patentlaan 2  
NL - 2280 HV Rijswijk  
Tel. (+31-70) 340-2040,  
Fax: (+31-70) 340-3016

Authorized officer

Bacon, Alan

## INTERNATIONAL SEARCH REPORT

International application No

PCT/US2015/066008

C(Continuation). DOCUMENTS CONSIDERED TO BE RELEVANT

Category*	Citation of document, with indication, where appropriate, of the relevant passages	Relevant to claim No.
X,P	WO 2015/095556 A1 (NOVARTIS AG [CH]; LIU ALICE WEIMIN [US]; HERRON GREGORY L [US]) 25 June 2015 (2015-06-25) page 2, lines 1-15 page 4, line 12 - page 5, line 4 page 8, lines 1-7 page 9, lines 1-22 claim 1; table 2B	1-14
X,P	----- WO 2015/095565 A1 (NOVARTIS AG [CH]; LIU ALICE WEIMIN [US]; DIETRICH BURKHARD [DE]) 25 June 2015 (2015-06-25) page 2, lines 1-28 page 3, lines 19-25 page 5, line 15 - page 6, line 8 claims 1, 5; figure 1; table 1 -----	1-14



# INTERNATIONAL SEARCH REPORT

Information on patent family members

International application No PCT/US2015/066008
---

Patent document cited in search report	Publication date	Publication date	Patent family member(s)	Publication date
JP 2000326347	A	28-11-2000	NONE	
US 2004207105	A1	21-10-2004	AU 4725301 A	15-10-2001
			US 2001054774 A1	27-12-2001
			US 2004207105 A1	21-10-2004
			WO 0174554 A2	11-10-2001
WO 2015095556	A1	25-06-2015	US 2015174663 A1	25-06-2015
			WO 2015095556 A1	25-06-2015
WO 2015095565	A1	25-06-2015	US 2015177422 A1	25-06-2015
			WO 2015095565 A1	25-06-2015