

(No Model.)

5 Sheets—Sheet 1.

J. A. BURDEN.
HORSESHOE MACHINE.

No. 524,307.

Patented Aug. 14, 1894.

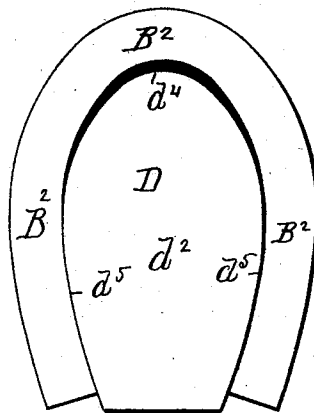
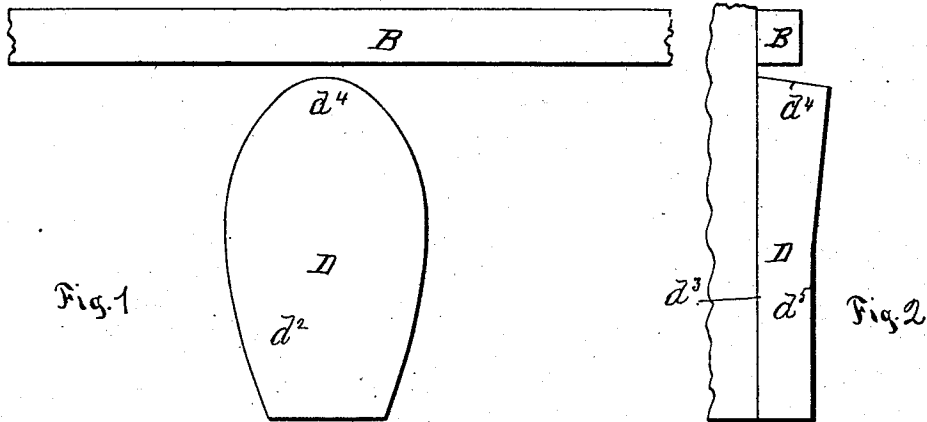

Fig. 3

WITNESSES:

Charles S. Brintnall
F. F. Bull

James A. Burden
INVENTOR

BY *W. C. Hagan*

ATTORNEY.

J. A. BURDEN.
HORSESHOE MACHINE.

No. 524,307.

Patented Aug. 14, 1894.

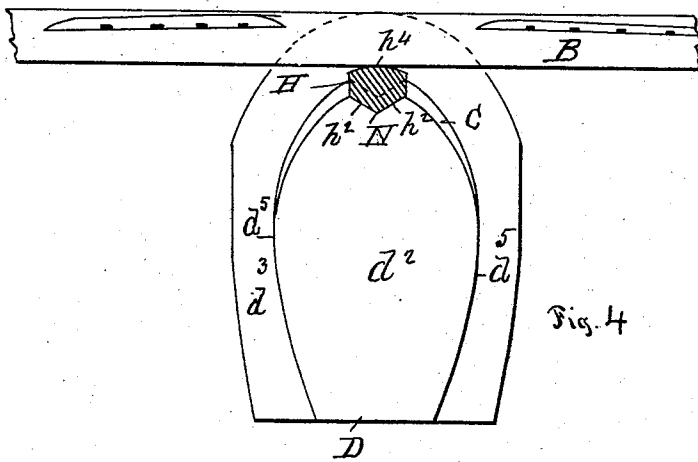

Fig. 4

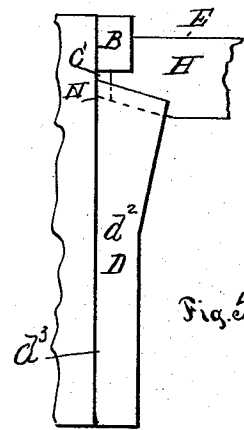

Fig. 5

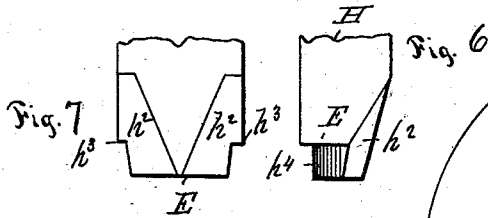

Fig. 7

Fig. 6

Fig. 8

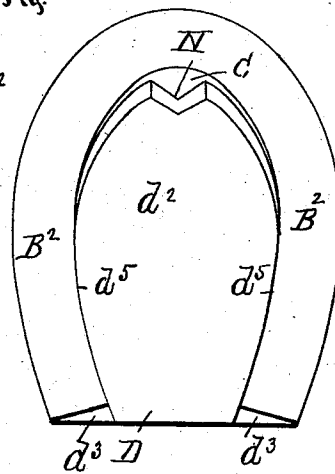

Fig. 9

WITNESSES:

Charles S. Brintnall
F. F. Buell

James A. Burden
INVENTOR

BY *W. C. Hagan*

ATTORNEY.

(No Model.)

5 Sheets—Sheet 3.

J. A. BURDEN.
HORSESHOE MACHINE.

No. 524,307.

Patented Aug. 14, 1894.

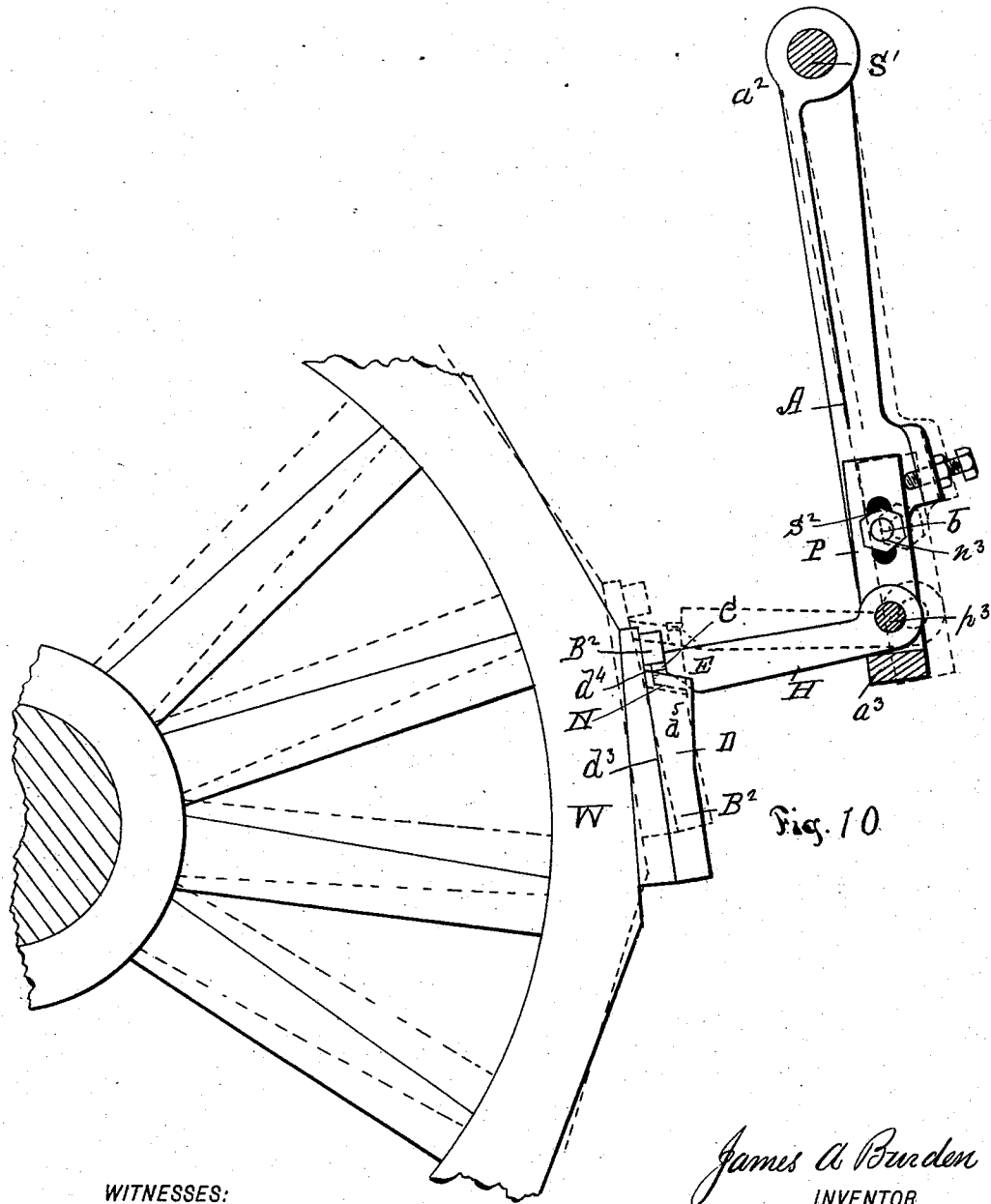

Fig. 10

WITNESSES:

Charles S. Brintnall
F. F. Bull

James A. Burden
INVENTOR

BY *W. E. Hagan*
ATTORNEY.

J. A. BURDEN.
HORSESHOE MACHINE.

No. 524,307.

Patented Aug. 14, 1894.

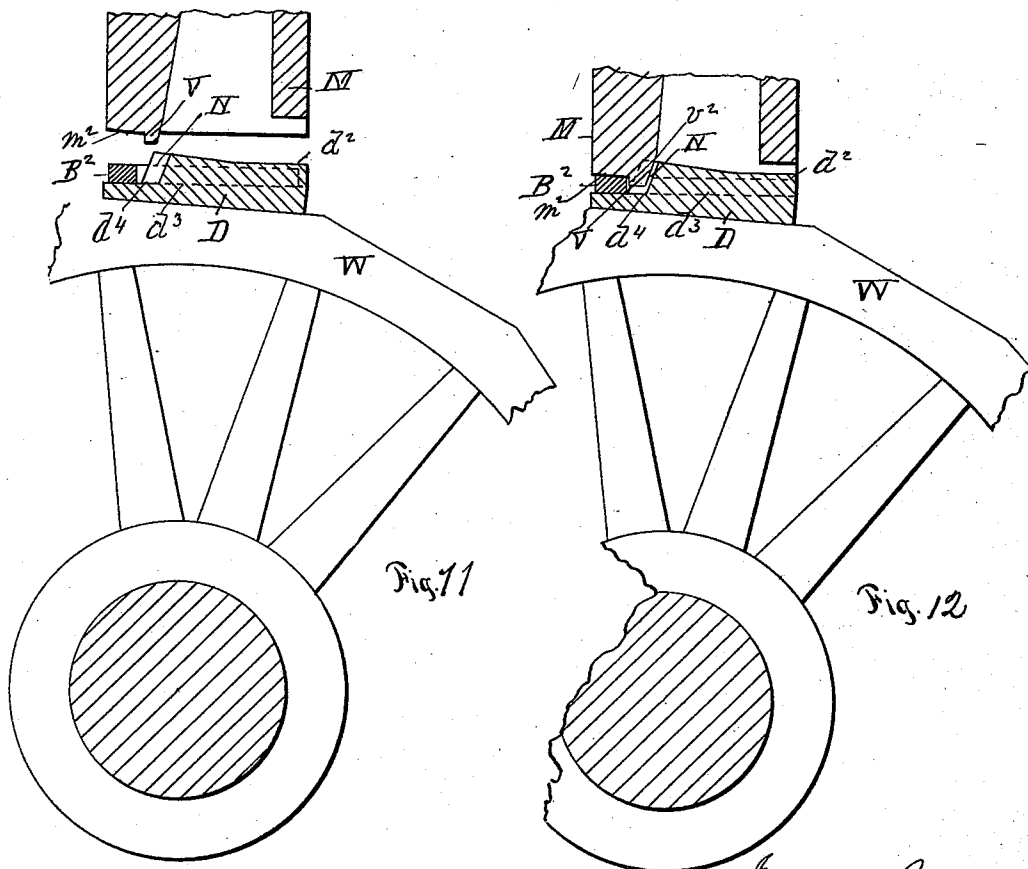

Fig. 11

Fig. 12

WITNESSES:

Charles S. Brimhall
F. F. Buell

James A. Burden.
INVENTOR

BY *W. E. Hagan*

ATTORNEY.

UNITED STATES PATENT OFFICE.

JAMES A. BURDEN, OF TROY, NEW YORK.

HORSESHOE-MACHINE.

SPECIFICATION forming part of Letters Patent No. 524,307, dated August 14, 1894.

Application filed August 9, 1893. Serial No. 482,711. (No model.)

To all whom it may concern:

Be it known that I, JAMES A. BURDEN, of the city of Troy, Rensselaer county, State of New York, have invented new and useful Improvements in Horseshoe-Machines, of which the following is a specification.

My invention relates to a means for bending the blanks from which horse shoes are made in advance of the toe end of the die on which they are top swaged so that the metal laterally displaced by the top swaging will be forced inwardly toward the die, and to adapt this procedure to be used in machines running with alternating periods of motion and rest, as distinguished from older machines of this class which were operated with continuous motion.

In older machines for making horse shoes, as heretofore practiced, blanks have been bent upon a frog-die, and then moved away from the die before being top swaged, and blanks have been bent in advance of the die, by a bender moving with the latter, as shown in the Patent No. 17,665, granted to Henry Burden June 30, 1857, and in both of which older machines designated, the shoes were top swaged by rotating dies, as distinguished from top swaging dies that were vertically reciprocated, and caused to descend upon the shoe while at rest, and in which position there was no tendency for the shoe to curl or buckle from the roller action of the swaging die. To accomplish these better results I bend the blank at a point a little in advance of the toe-end of the frog-form die, so as to leave a C-form space between the inner edge of the blank, and the toe end of the frog-die, around which the blank is bent, into which space the metal forced laterally by the top pressure of the swaging die may enter and thus avoid the necessity of forcing it outwardly, or inwardly to produce a fin on the edge of the shoe, during the operation of swaging.

Accompanying this specification to form a part of it there are five plates of drawings containing thirteen figures illustrating my invention with the same designation of parts by letter reference used in all of them.

Of the illustrations Figure 1, shows the relative position of the blank to the frog-form die before the blank is bent upon the latter, to produce a space between the toe-end of the die-

frog and the bent blank. Fig. 2, shows in side elevation the parts shown at Fig. 1, and Fig. 3, shows in a plan view the shoe-blank after having been bent around the die-frog in advance of the toe-end of the latter, and the position of the space between the toe-end of the die-frog, and the bent blank. Fig. 4, shows in plan one of the frog-form dies of a die-wheel separated from the latter; illustrating also an angular recess formed in the toe-end of the die-frog, a blank-holder entered therein, and shown in cross-section, and a blank which has been broken off at its ends for convenience in illustration; and which blank is shown in a position to be bent according to my improved method. Fig. 5, is a side elevation of the parts shown at Fig. 4. Fig. 6, is a side view of that end of the blank-holder which by its form is adapted to enter an angular recess in the toe-end of the frog-die; this illustration shows a part of the angular side of the holder and a part of the rounded edge of the latter on which the blank is bent; also a shoulder formed in the blank-holder above its rounded edge. Fig. 7, shows the angular side of the entering end of the blank-holder with its angular face fronting the view; Fig. 8, an end view of its entering end, and Fig. 9, illustrates the blank as having been bent around the frog-die and with the blank-holder removed. Fig. 10 shows a side view of a part of the die-wheel, the arm which operates the blank holder bracket, and holder; one of the frog-dies, with the rock-shaft, which actuates the holder, and the pivotal connection the latter makes with the arm bracket shown in cross section. The position of the blank holder when within a recess in the frog-die being indicated in full lines, and as removed by dotted lines. Fig. 11 is a side view of a part of the die-wheel, with one of the frog-dies, the blank and swaging die, as well as the die-wheel shaft shown in section, and with the swaging-die shown in a position to descend upon the partly formed shoe. Fig. 12 shows the same parts that are illustrated at Fig. 11, but with the swaging-die as operated to descend on the bent blank. Fig. 13 is a perspective of a machine for making horse shoes with my improved method and means made applicable thereto.

The machine to which my invention is shown

as applied and made applicable is that one embodying the general features which are illustrated and described in Letters Patent No. 373,125, granted to me November 15, 1887.

5 The several parts of the apparatus thus illustrated are designated by letter reference and the function of the parts is described as follows:

10 The letter F designates the frame or housing of the machine, J' its main driving shaft actuated by a pulley not shown, J² its shaft operating the bending mechanism, and S' the blank-holder rock-shaft, arranged to have its bearings in brackets *m*².

15 The letters O, O, designate the benders actuated by cams O², O², on the shaft J², these benders at their lower ends being made with rollers *r*, and arranged to run in guides *g*.

20 The letter G' designates a gear-wheel arranged on the driving shaft J', and G² another gear-wheel mounted on the shaft J², adapted to mesh into the gear-wheel G'.

25 The letters G³ designate beveled gears of which there is one at each side of the machine arranged on the shaft J', which gears each mesh into a beveled gear-wheel G⁴, at each side of the machine to operate the side swagers *g*⁵ *g*⁵.

30 The letter J⁴ designates the die-wheel shaft, and W the die-wheel.

35 The letter R designates a double ratchet-wheel arranged on the end of the die-wheel shaft, where extended through its bearing in the frame, and T a pawl-holder arranged eccentrically on the shaft J', by which the ratchet-wheel is actuated to move the die-wheel shaft and die-wheel with intermittent periods of motion and rest.

40 The letters D designate the frog-dies, which are arranged on the flat faces *f*, of the die-wheel, although but two of these dies are shown, at Fig. 13. These frog-dies are shown as separated from the machine at Figs. 1, 2, 3, 4, 5 and 9, and are mounted thereon at Figs. 11, 12 and 13.

45 The letter B designates a blank, and B² the blank after it has been bent around one of the frogs *d*², by the benders O, O, to rest upon the flat plate surface *d*³, of the die proper encircling the latter at its sides *d*³, and toe-end *d*⁴.

50 The letter N designates an angular recess which is formed in the toe-end of the die-frogs *d*², and this recess is cut out of the frog at its toe-end to extend down through the latter to the top of the die-plate *d*³.

55 The letter H designates a blank-holder which at its recess-entering end E, is made to have an angular face *h*², on one of its sides adapting it to enter the angular recess N, in the die-frog, and this blank holder is made with a shoulder *h*³, and a rounded outer face *h*⁴, below the latter, and which rounded face when the blank-holder is entered within the recess N, projects beyond the toe-end *d*⁴ of the die-frogs, so that as the blank is bent on the rounded projecting outer edge of the

holder to curve inwardly against the sides of the die-frog, it is so bent in advance of the toe-end of the latter, and thus incloses the space C, between the toe-end of the die-frog 70 and the inner edge of the blank. This blank-holder is arranged upon the lower end of an arm A, which latter at its upper end is keyed on to the rock-shaft S', and by which said arm is operated to swing outwardly and inwardly at its lower end. 75

The letter P designates a bracket which is made adjustable to the lower end of said arm by means of a slot S², formed in said bracket, a bolt *b* projected from the latter, and a nut *n*³, 80 threaded on said bolt. This bracket holder is on its inner end journaled on to the pintle shaft *p*³, connected to the bracket, and on which journaled connection the blank holder can rise or fall at its outer end. When this 85 blank holder is in position to enter the recess N, by the movement of the arm A, the holder rests on the offset arm *a*³, of the bracket P, and after having been actuated to enter the recess N, its movement is timed to have it remain therein while the blank is being bent 90 around its projecting rounded edge, and the frog-die *d*².

As the arm A recedes, and the die-wheel and frog-die on the latter with which the 95 holder engages advances, the blank holder is free to rise on its outer end, while being drawn outwardly from the die-frog, and after the passage of the latter to again rest on the bracket arm as before, to be again actuated 100 by the rock-shaft S', on the coming into position of another die-frog and shoe-blank; the intermittent periods of motion and rest given to the die-wheel and frog-dies being timed to have the arm A, actuate the blank-holder, the 105 moment the die-wheel stops, and to have it remain within the recess while the blank is being bent and to draw out therefrom when the die-frog and die-wheel commence an advance movement. 110

The letter M designates a swaging die which is operated to descend on to the shoe after the latter has been bent from a blank form around the die-frog as before described; and is retained thereon, with the shoe resting 115 on the flat die-plate *d*³. The function of this die M is to straighten out the shoe while resting on the die-plate *d*³, to form any desired concavity in the top of the shoe, by forcing inwardly toward the die-frog within the 120 space between the blank and the toe-end of the die-frog, (where the blank is bent in advance of the latter,) the metal moved laterally to produce such shaping or concavity. This swaging die is operated by a connection 125 made with the driving shaft, which is not shown, by which it is vertically reciprocated.

At the toe-end of the swaging-die-face there is projected downwardly therefrom the angular plate V, which latter as the swaging- 130 die descends enters the recess N, made in the toe-end of the die-frog, before the shaping

and swaging face of the die M, commences to engage with the top of the shoe. This projecting plate V, on its outer face is in curved alignment at v^2 , with the toe-end of the die-frog, and when entered within the recess N, it forms thereat a closing edge against which the metal forced inwardly by the swaging die will finish.

To carry out the purposes of my invention a series of frog-form dies arranged to be moved connectedly with alternating periods of motion and rest are essential, with the blanks bent around the dies so as to be in advance of the toe-ends of the latter, to put the shoes into a position to be properly swaged by the descent of a swaging die.

The essential feature of my improvement in the manufacture of horse shoes as applied to horseshoe machines operating with alternating periods of motion and rest, is to bend the blank in advance of the die-frog to form a space between the latter and the blank, so that when top swaged for shaping or the production of concavity, the metal moved laterally will fill this space, rather than crowd outwardly when the blank is in contact with the die-frog and thus change the outward contour of the shoe; hence I do not limit my invention to the use of the precise means illustrated and described herein, but I do limit it to the use of such connected process steps as will in their application as well as in their sequence produce the same results.

Having thus described my invention, what I claim, and desire to secure by Letters Patent, is—

1. The combination with a series of frog-form dies operated to move connectedly with alternating periods of motion and rest, of a blank-holder and mechanism for actuating said blank-holder whereby it is adapted to enter a recess formed in the toe-end of each of the die-frogs when at rest, and to project thereat beyond the latter, on which projection of the blank-holder and on the die frog, the blank can be bent; and whereby said

blank-holder is also adapted to move out from its engagement with the die frog, when the bending is completed, substantially in the manner as and for the purposes set forth. 50

2. In the manufacture of horse shoes, the combination of a series of frog-formed dies, operated to move connectedly with alternating periods of motion and rest; a holder and mechanism for operating said holder whereby it is adapted to enter a recess made in the toe-end of each of the die-frogs to project beyond the toe-end of the latter, and to remain therein while the frog-form die is at rest, and a blank is being bent thereon, and then to recede therefrom; a swaging die operated to descend on to the bent shoe and frog-form die at a succeeding period of rest to top-swage the shoe, and then recede before the frog-form die moves, substantially in the manner as and for the purposes set forth. 55 60 65

3. In an apparatus for bending horse shoe blanks, and in succession top-swaging them, the combination with a series of frog-formed dies connectedly operated to move with alternating periods of motion and rest, and each made with a recess in its toe-end, of a blank-holder and mechanism for operating said holder whereby it is adapted and operated to enter the recess of the adjacent frog-form die to project beyond it, and to remain therein until the blank is bent on the holder and the die frog, and then to recede therefrom; and a swaging-die having a plate at its toe-end on its under surface adapted as the swaging-die descends to enter the recess in the die-frog, and to top-swage the shoe when the latter and the frog-die are at a succeeding period of rest, substantially in the manner as and for the purposes set forth. 70 75 80 85

Signed at the city of Troy, New York, this 7th day of July, 1893, in the presence of the two witnesses whose names are hereto written.

JAS. A. BURDEN.

Witnesses:

W. E. HAGAN,
NICHOLAS J. GABLE.

Correction in Letters Patent No. 524,307.

It is hereby certified that in Letters Patent No. 524,307, granted August 14, 1894 upon the application of James A. Burden, of Troy, New York, for an improvement in "Horseshoe-Machines," an error appears in the printed specification requiring the following correction, viz: In line 111, page 2, the word "smoking" should read *swaging*; and that the said Letters Patent should be read with this correction therein that the same may conform to the record of the case in the Patent Office.

Signed, countersigned, and sealed this 4th day of September, A. D. 1894.

[SEAL.]

JNO. M. REYNOLDS,
Assistant Secretary of the Interior.

Countersigned:

S. T. FISHER,
Acting Commissioner of Patents.