

FOR THE PURPOSES OF INFORMATION ONLY

Codes used to identify States party to the PCT on the front pages of pamphlets publishing international applications under the PCT.

AT	Austria	FR	France	MR	Mauritania
AU	Australia	GA	Gabon	MW	Malawi
BB	Barbados	GB	United Kingdom	NE	Niger
BE	Belgium	GN	Guinea	NL	Netherlands
BF	Burkina Faso	GR	Greece	NO	Norway
BG	Bulgaria	HU	Hungary	NZ	New Zealand
BJ	Benin	IE	Ireland	PL	Poland
BR	Brazil	IT	Italy	PT	Portugal
BY	Belarus	JP	Japan	RO	Romania
CA	Canada	KP	Democratic People's Republic of Korea	RU	Russian Federation
CF	Central African Republic	KR	Republic of Korea	SD	Sudan
CG	Congo	KZ	Kazakhstan	SE	Sweden
CH	Switzerland	LI	Liechtenstein	SI	Slovenia
CI	Côte d'Ivoire	LK	Sri Lanka	SK	Slovak Republic
CM	Cameroon	LU	Luxembourg	SN	Senegal
CN	China	LV	Latvia	TD	Chad
CS	Czechoslovakia	MC	Monaco	TG	Togo
CZ	Czech Republic	MG	Madagascar	UA	Ukraine
DE	Germany	ML	Mali	US	United States of America
DK	Denmark	MN	Mongolia	UZ	Uzbekistan
ES	Spain			VN	Viet Nam
FI	Finland				

Description**Novel Diffuser Body and Process for Preparing**Technical Field

A ceramic diffuser body containing a ceramic substrate and a ceramic coating on the top surface of the substrate is disclosed.

Background Art

Porous gas diffusion elements are well known to those skilled in the art. These prior art porous gas diffusers are often used to diffuse a gas (such as oxygen, ozone, air, carbon dioxide, or nitrogen) into a liquid (such as waste water or drinking water). An ASCE Standard Test ("Measurement of Oxygen Transfer in Clean Water," July, 1984, ISBN 0-87262-430-7) was developed by the American Society of Civil Engineers to evaluate the efficiencies of these prior art devices.

A substantial amount of energy is required to force gas through such porous gas diffusers. The efficiencies of the prior art gas diffusion devices ranged from about 10 to about 40 percent. Thus, even a relatively small increase in such efficiency will result in a significant decrease in energy consumption.

It is an object of this invention to provide a porous gas diffuser with an increased gas transfer efficiency.

It is yet another object of this invention to provide a porous gas diffuser whose output is substantially uniform along its active surface.

It is yet another object of this invention to provide a porous gas diffuser which, when connected a source of gas, is less likely to leak such gas from a source other than the active surface of the diffuser.

Disclosure of the invention

In accordance with this invention, there is provided a ceramic diffuser body which contains a ceramic substrate coated with a ceramic membrane. The minimum active pore size of the substrate is from about 2 to about 5 times as great as the minimum active pore size of the ceramic membrane.

Brief description of the drawings

The present invention will be more fully understood by reference to the following detailed description thereof, when read in conjunction with the attached drawings, wherein like reference numerals refer to like elements, and wherein:

Figure 1 is a flow diagram of one preferred process of the instant invention;

Figure 2 is a sectional view of one preferred diffuser of the instant invention;

Figure 3 is a sectional view of the diffuser of Figure 2 connected to a source of gas; and

Each of Figures 4 and 5 is a sectional view of another preferred diffuser of the instant invention.

Best Mode for Carrying Out the Invention

Figure 1 illustrates one preferred process for producing the diffuser body of this invention.

Referring to Figure 1, to mixer 10 is charged aggregate material and bonding agent. The aggregate material is preferably charged via line 12. The bonding agent is charged via line 14.

In one preferred embodiment, which is illustrated in the drawings and referred to in the remainder of this specification, the aggregate material consists essentially of ceramic material.

The ceramic material charged via line 12 preferably has a particle size distribution such that at least about 99 weight percent of its particles have a maximum dimension which

is from about 150 to about 1,000 microns. In one embodiment, at least about 99 weight percent of the ceramic aggregate particles charged via line 12 have a maximum dimension of at least about 250 microns.

The ceramic aggregate material charged via line 12 preferably has a shrinkage such that, after it is formed into a green body with a substantially circular cross-section and a diameter of 7.0 inches and fired at a temperature of 1,225 degrees Centigrade for 1 hour, will exhibit a shrinkage of less than about 1.0 percent. The shrinkage of the material may be determined by measuring the diameter of body prior to and after firing.

From about 80 to about 95 weight percent (by combined weight of ceramic aggregate material and bonding agent) is charged to mixer 10 via line 12; and from about 20 to about 5 weight percent of bonding agent is charged to mixer 10 via line 14.

In one preferred embodiment, the ceramic material charged via line 12 is selected from the group consisting of alumina, silicon carbide, silica, mullite, zirconium silicate, and the like.

In one embodiment, the ceramic material charged via line 12 is silica, which often consists of naturally occurring sand particles. An amorphous glass binder may be added to the silica (via line 14); see, e.g., page 2 of EPA/625/8-85/010 Summary Report, "Fine Pore (Fine Bubble) Aeration Systems" (developed by the Water Engineering Research Laboratory, Cincinnati, Ohio).

In one embodiment, the ceramic material charged via line 12 is an alumina material such as, e.g., a 46 grit alumina sold by General Abrasive Treibacher, Inc. of Niagara Falls, New York. An elaborate binder, resembling porcelain, may be charged via line 14; see, e.g., page 3 of said E.P.A. report.

In one embodiment, the ceramic material charged via line 12 is zircon ($ZrSiO_4$). In another embodiment, the ceram

ic material charged via line 12 is silicon carbide.

Mullite may be used as the ceramic material charged via line 12. As is known to those skilled in the art, mullite is an aluminosilicate of the formula $3\text{Al}_2\text{O}_3 \cdot 2\text{SiO}_2$.

It is preferred to use alumina as the ceramic aggregate material charged via line 12, and reference will be made to such alumina in the remainder of this specification.

In addition to the alumina (which is charged via line 12), from about 5 to about 20 weight percent of a bonding agent is charged via line 14. This bonding agent consists essentially of inorganic material, all of whose particles have a maximum dimension smaller than about 100 microns. The bonding agent preferably forms a glassy phase when subjected to a temperature of 1,225 degrees for at least 1 hour.

In one preferred embodiment, a borosilicate glass is used as the bonding agent. This borosilicate glass may be formed by combining a borosilicate frit and nepheline syenite in a mixture which contains from about 20 to about 50 weight percent of borosilicate frit and from about 50 to about 80 weight percent of nepheline syenite.

In one preferred embodiment, the bonding agent charged via line 14 is a mixture of from about 20 to about 50 weight percent of a clay material and from about 80 to about 50 weight percent of a material selected from the group consisting of feldspar, nepheline syenite, and mixtures thereof. The clay material preferably has a particle size such that substantially all of its particles have a maximum dimension smaller than about 10 microns; and it may, e.g., be ball clay or bentonite. The feldspar and/or the nepheline syenite material preferably has a particle size such that substantially all of its particles are smaller than 40 microns.

In one embodiment, the bonding agent also contains from about 20 to about 50 weight percent of glass frit.

The ceramic aggregate material and the bonding agent are mixed in mixer 10, preferably by dry mixing, until a

substantially homogeneous mixture is obtained therein. Any of the mixers known to those skilled in the art may be used.

Thus, e.g., one may use an Eirich R7 Mixer (Eirich Machines, Ltd., Box 550, Maple, Ontario).

After the desired dry mixture of ceramic material and binding agent has been obtained in mixer 10, it is preferred to charge thereto via line 16 from about 3 to about 6 weight percent of a green binder which, preferably, is in liquid form. Some suitable binders which may be used are described on page 153 of James S. Reed's "Introduction to the Principles of Ceramic Processing" (John Wiley and Sons, New York, 1988).

By way of illustration, one may as a green binder an emulsion of paraffin in water, a Carbowax solution in water, polyvinyl alcohol, dextrine, and the like. In one embodiment, it is preferred to use from about 3 to about 8 weight percent of a combination of dextrine and Mobilcer J wax. Thus, in this embodiment, e.g., one may add from about 2 to about 4 weight percent of each of dextrine and Mobilcer J wax.

After the binder has been added via line 16, the mixture is then stirred until it is substantially homogeneous. Thereafter, the mixture is discharged via line 18 to former 20.

Any conventional means can be used to form the mixture in former 20. Thus, by way of illustration and not limitation, former 20 may be a press equipped with a die in the shape of a plate, a dome, or a disc. Any suitable press may be used such as, e.g., the 30-ton presses sold by the Fred S. Carver Inc. of Menomonee Falls, Wisconsin.

The green body produced by former 20 may be in the form of a plate with a thickness of from about 1.0 to about 1.5 inches thick. The plate may have a shape which is square, or rectangular.

Alternatively, the green body produced by former 20 may be in the form of a disc with a diameter of from about 6 to about 12 inches and a thickness of from about 0.5 to about 2.0

inches. In one embodiment, the thickness of the disc is from about 0.5 to about 1.0 inches. In one embodiment, the diameter of the disc is either 7 inches, or 9 inches, or 9.5 inches, or 12 inches. See, e.g., page 6 of said E.P.A. report.

It is preferred that the green body produced in former 20 be in the shape of a dome, resembling a circular disk with a downwardly turned edge. In one embodiment, these domes are also from about 6 to about 12 inches in diameter and from about 0.5 to about 2.0 inches thick. In one embodiment, the dome is about 7.0 inches in diameter and 1.5 inches high; in this embodiment, the media is 0.6 inches thick on the edges and 0.75 inches thick on the top or flat surface. See, e.g., page 5 of said E.P.A. report and a publication by D.H. Houck et al. entitled "Survey and Evaluation of Fine Bubble Dome Diffuser Aeration Equipment," EPA-600/2-81-222, NTIS no. PB82-105578 (United States Environmental Protection Agency, Cincinnati, Ohio, September, 1981). In another embodiment, the dome has a diameter of about 9 inches. In yet another embodiment, the dome has a diameter of about 12 inches.

The green body formed in former 20 is then passed via line 22 to furnace 24, where it is heated to a temperature of 1,225 degrees Centigrade and maintained at at least this temperature for at least 1 hour. It is preferred to heat the green body in air at a temperature of from about 1,225 to about 1,275 degrees Centigrade for at least about 8 hours. Thereafter, the heated body is then allowed to cool, preferably while in furnace 24.

Any conventional furnace may be used to heat the green body. Thus, e.g., one may use a tunnel kiln sold by the Lindberg Company, 304 Hart Street, Watertown, Wisconsin.

The materials required to produce an inorganic coating for the green body from furnace 24 may be charged to mixer 26. It is preferred that the mixture formed in mixer 26 have a coefficient of expansion which is from about 0.9 to about 1.1 times as great as the coefficient of expansion of the mixture

formed in mixer 24.

Ceramic aggregate material is charged via line 28 to mixer 26. It is preferred that the ceramic aggregate material charged via line 28 be chemically identical to the ceramic aggregate material charged via line 12. However, the aggregate material charged via line 28 has a particle size distribution such that substantially all of its particles have a maximum dimension less than about 150 microns and, more preferably, less than about 50 percent of the size of the mean particle size of the ceramic aggregate material charged via line 12. By way of illustration, in one embodiment the alumina charged via line 12 has a mean particle size of greater than 250 microns, and the alumina charged via line 28 has a mean particle size of about 95 microns.

Bonding agent is charged to mixer 26 via line 30. It is preferred that a sufficient amount of such bonding agent be charged so that the mixer 26 contains from about 80 to about 95 weight percent of ceramic aggregate material and from about 20 to about 5 weight percent of bonding agent. A similar, or identical bonding agent may be charged via line 30 as is charged via line 14; it is preferred that the binding charged in the former line be identical to the binding agent charged via the latter line.

A sufficient amount of water is charged to mixer 26 via line 32 so that the slurry formed in such mixer has a solids content of from about 40 to about 60 weight percent.

Less than about 1.0 weight percent (and preferably less than about 0.1 weight percent) of surfactant may be added to mixer 26 via line 34. If such surfactant is used, it preferably is an anionic surfactant. Thus, e.g., one may use "DARVAN" 821A polyacrylate surfactant, which is sold by the R.T. Vanderbilt and Company of Norwalk, Connecticut.

From about 0.25 to about 0.5 weight percent of a suspending agent is added to mixer 26 via line 36. The function of this suspending agent is to suspend and maintain a mixture

of the particulate components homogeneously. One may use suspending agents such as, e.g., Xanthan gum.

The ingredients are mixed in mixer 26 until a substantially homogeneous slurry is produced. Thereafter, the slurry is discharged via line 38 to coater 40. It is preferred that substantially all of the particles in the slurry are smaller than about 125 microns and, more preferably, less than about 100 microns.

The green body from furnace 24 is passed via line 52 to coater 40. Its interior surface (see Figure 2) is masked, and the top surface of the green body is dipped into the slurry; thus, the green body is only partially coated with the slurry. The partially coated green body is then removed from coater 40, the top surface is then allowed to dry, and then the green body is again dipped into the slurry in order to coat the bottom surface of the green body. Thereafter, the partially coated green body is again removed from the coater 40 and allowed to dry.

The partially coated green body is then removed from coater 40 and charged via line 44 to furnace 46, where it is fired in accordance with the procedure used in furnace 24. It is preferred to heat the coated green body at a temperature of from about 1,225 to about 1,275 degrees Centigrade for at least about 1 hour and, more preferably, for at least about 8 hours.

A sectional view of one preferred porous gas diffuser body is illustrated in Figure 2. Referring to Figure 2, it will be seen that, in this embodiment, diffuser 48 is preferably a dome-shaped body 50 comprised of gas inlet orifice 52. The diameter 54 of body 50 is at least about 3.0 times as large as the maximum diameter 56 of gas inlet orifice 52; and the cross-sectional area of the solid portion of body 50 (the sum of the areas of sections 58 and 60) is at least about 3.5 times as great as the cross-sectional area of the hatched orifice area 52.

In the embodiment illustrated in Figure 2, the coating is prepared from alumina and a bonding agent containing about 30 weight percent of ball clay and 70 weight percent of nepheline syenite. In this embodiment, the coating 62 has a thickness which has a thickness which is from about 0.1 to about 1.0 millimeters and, generally, is less than about 5 percent of the thickness 64 of the substrate 66. In one preferred embodiment, the maximum thickness of substrate 66 is 1.5 inches, and the coating 62 has a thickness of from about 0.4 to about 0.6 millimeters.

The substrate 66 preferably has an apparent porosity of from about 35 to about 50 percent; as is known to those skilled in the art, apparent porosity is the relationship of the open pore space to the bulk volume, expressed in percent (see A.S.T.M. C242-87). The coating 62 also has an apparent porosity of from about 35 to about 55 percent. Although the porosity of the coating 62 may be identical to or smaller than the porosity of substrate 66, it often is at least about 2.0 percent higher than the porosity of substrate 66.

The substrate 66 must have sufficient strength for its intended use. In one embodiment, the substrate 66 has a strength of at least about 1,000 pounds per square inch. For discs and domes, measurement of strength usually involves supporting the diffuser in a fashion similar to that used for the final assembly and then applying a 1,000 pound load to a 25 millimeter (1.0 inch) diameter area in the center of the diffuser.

The minimum active pore size of substrate 66 is greater than the minimum active pore size of coating 62. As used in this specification, the term minimum active pore size refers to the smallest pore in the diffuser which is actively diffusing gas into the liquid medium. As is known to those skilled in the art, the pore size distribution of a porous body may be determined in accordance with A.S.T.M. Standard Test Method F316-86, "Test Method for Pore Size Characteristics of Mem

brane Filters for Use with Aerospace Fluids." In this test, porous bodies are mounted on a gas plenum and immersed in a liquid of known surface tension. The plenum is slowly pressurized, and observations are made of the pressure at which the first bubble is released from the body at various gas flow rates.

The minimum active pore size of substrate 66 is generally from about 40 to about 120 microns. The minimum active pore size of coating 62 is generally from about 10 to about 40 microns. In general, the minimum active pore size of substrate 66 is from about 2.0 to about 5.0 times as great as the minimum active pore size of coating 62. It is preferred that the minimum active pore size of substrate 66 be from about 2.0 to about 4.0 times as great as the minimum active pore size of coating 62. In one preferred embodiment, the minimum active pore size of substrate 66 is about 3.0 times as great as the minimum active pore size of coating 62.

Referring again to Figure 2, in one preferred embodiment, the minimum active pore size of the coating 62 on the top surface 68 of substrate 66 is at least about 2.0 times as great as the minimum active pore size of the coating 62 on the bottom surface 70 of substrate 66. This difference in minimum active pore size may be obtained, e.g., by using different particle size materials to coat the top and bottom surfaces of the substrate. To activate the top surface for diffusion while maintaining a seal on the bottom surface, a coarser membrane may be used on the top. This may be achieved, e.g., by using a coarser grade of ceramic aggregate for the top surface membrane, and using a finer grade of ceramic aggregate for the bottom surface membrane.

Figure 3 illustrates the diffuser body 48 of Figure 2 connected to a source of gas 72; this embodiment is especially suitable for diffusing ozone gas. Referring to Figure 3, it will be seen that diffuser body 48 is attached to inlet casting 74 by means of bolt 76, gasket 78, and gasket 80. In

this embodiment, bolt 76 is preferably a stainless steel bolt. Gaskets 78 and 80 are preferably an ozone-resistant elastomeric material such as "HYPALON" 70 (a chlorosulfonated polyethylene sold by the Du Pont de Nemours and Company of Wilmington, Delaware).

As is disclosed on pages 22-24 of EPA/625/1/-89/023, "Design Manual: Fine Pore Aeration Systems," United States Environmental Protection Agency, Center for Environmental Research Information, Cincinnati, Ohio, the uniformity of individual diffusers, and the entire aeration system, is important if high oxygen transfer efficiencies are to be attained

The uniformity of the diffuser body may be tested with a visual test. Alternatively, or additionally, the uniformity of the diffuser may be tested with the uniformity tests described in the Environmental Protection Agency's "Design Manual -- Fine Pore Aeration Systems" (EPA/625/1-89/023, published in 1989 by the Center for Environmental Research Information, Risk Reduction Engineering Laboratory, Cincinnati, Ohio). One such uniformity test measures the water displaced from an inverted graduated cylinder in a given period of time and compares the flow rate so determined for a specific location above the diffuser to other areas. A diffuser's uniformity can be measured by comparing the values for different areas of its active surface.

Figure 4 is a sectional view of another preferred embodiment of applicant's invention, illustrating a conically-shaped diffuser body. This sectional view, like the sectional views depicted in Figures 2 and 3, was taken through a section taken through the centerpoint of the top surface of the diffuser body.

Referring to Figure 4, diffuser body 82 is comprised of substrate 84 and coating 86, which are similar to the substrate 66 and coating 62 depicted in Figures 2 and 3. As with the diffuser body of Figures 2 and 3, the coating 86 is not

applied to the interior surfaces 88 and 90 of the diffuser body 82.

Figure 5 is a sectional view of another preferred embodiment of applicant's invention, illustrating another conically-shaped diffuser body 91. Referring to Figure 5, it will be seen that substrate 92 is coated with coating 94 over substantially every exterior surface except for exterior surfaces 96 and 98. Thus, unlike the embodiment of Figure 3, the tip 100 contains operative diffusing material (coating 94).

An adaptor, such as adaptor 102, is connected to substrate 92 by conventional means such as, e.g., adhesive 104, adhesive 106, and adhesive 108. In the preferred embodiment illustrated in Figure 5, adaptor 102 preferably contains pipe threads 104 and a flat section 106 which a wrench may grasp.

The adaptor 102 may be made from conventional materials such as, e.g., plastic material (such as polyvinyl chloride), metal material (such as stainless steel), and the like.

It will be apparent to those skilled in the art that the self-supporting diffuser head embodiments of applicant's invention are substantially less expensive than the prior art devices which required fabricated holders (which often consisted of plastic or stainless steel) and which usually communicated with precise orifices and often presented leakage problems at the junctures of the holders and the diffuser bodies. Applicant's devices are substantially less likely to present such leakage problems and are greatly simplified structures.

It will also be apparent to those skilled in the art that applicant's invention is not limited to diffuser bodies with the shapes depicted in Figures 2, 3, 4, and 5. Thus, differently shaped diffuser bodies may be made in accordance with applicant's invention such as, e.g., diffuser bodies with the shape of disks, square plates, rectangles, and prismatic shapes.

It is to be understood that the aforementioned description is illustrative only and that changes can be made in the apparatus, in the ingredients and their proportions, and in the sequence of combinations and process steps, as well as in other aspects of the invention discussed herein, without departing from the scope of the invention as defined in the following claims.

I claim:

1. A rigid, monolithic, porous gas diffusion element which is formed of a body of solid particles and which is comprised of a partially coated, permeable ceramic substrate, wherein:

(a) said substrate is an integral structure comprised of a top substrate surface, a bottom substrate surface, and an orifice extending upwardly from bottom substrate surface and defining an interior substrate surface, wherein the maximum dimension of said substrate is at least 3 times as large as the maximum dimension of said orifice;

(b) said substrate consists essentially of a porous first ceramic material, has an apparent porosity of from about 35 to about 50 percent, and has a minimum active pore size of from about 40 to about 120 microns;

(c) said substrate is coated with a coating which is bonded to and extends over said top substrate surface and said bottom substrate surface, wherein:

1. said coating is not bonded to and does not extend over said interior substrate surface;

2. said coating consists essentially of a second ceramic material has an apparent porosity of from about 35 to about 55 percent, and has a minimum active pore size of from about 10 to about 40 microns; and

3. the minimum active pore size of said substrate is from about 2 to about 5 times as great as the minimum active pore size of said coating.

2. The gas diffusion element as recited in claim 1, wherein said gas diffusion element is dome-shaped.

3. The gas diffusion element as recited in claim 2, wherein said first ceramic material is comprised of at least about 80 weight percent of alumina.

4. The gas diffusion element as recited in claim 3, wherein

said second ceramic material is comprised of at least about 80 weight percent of alumina.

5. The gas diffusion element as recited in claim 4, wherein said gas diffusion element has a diameter of from about 6 to about 12 inches.

6. The gas diffusion element as recited in claim 5, wherein said orifice has a diameter of from about 1.5 to about 2.5 inches.

7. A gas diffusion apparatus comprised of a rigid, monolithic, porous gas diffusion element which is formed of a body of solid particles and which is comprised of a partially coated, permeable ceramic substrate, and means for supplying gas to said gas diffusion element, wherein:

(a) said substrate is an integral structure comprised of a top substrate surface, a bottom substrate surface, and an orifice extending upwardly from bottom substrate surface and defining an interior substrate surface, wherein the maximum dimension of said substrate is at least 3 times as large as the maximum dimension of said orifice;

(b) said substrate consists essentially of a porous first ceramic material, has an apparent porosity of from about 35 to about 50 percent, and has a minimum active pore size of from about 40 to about 120 microns;

(c) said substrate is coated with a coating which is bonded to and extends over said top substrate surface and said bottom substrate surface, wherein:

1. said coating is not bonded to and does not extend over said interior substrate surface;
2. said coating consists essentially of a second ceramic material has an apparent porosity of from about 35 to about 55 percent, and has a minimum active pore size of from about 10 to about 40 microns; and
3. the minimum active pore size of said sub-

strate is from about 2 to about 5 times as great as the minimum active pore size of said coating.

8. The gas diffusion apparatus as recited in claim 7, wherein said gas diffusion element is dome-shaped.

9. The gas diffusion apparatus as recited in claim 8, wherein said first ceramic material is comprised of at least about 80 weight percent of alumina.

10. The gas diffusion apparatus as recited in claim 9, wherein said second ceramic material is comprised of at least about 80 weight percent of alumina.

11. The gas diffusion apparatus as recited in claim 10, wherein said gas diffusion element has a diameter of from about 6 to about 12 inches.

12. The gas diffusion apparatus as recited in claim 11, wherein said orifice has a diameter of from about 1.5 to about 2.5 inches.

13. A process for preparing a gas diffusion element, comprising the steps of:

(a) mixing from about 80 to about 95 weight percent of a first ceramic aggregate with from about 20 to about 5 weight percent of a first bonding agent, wherein:

1. at least about 99 weight percent of the particles of said first ceramic aggregate have a maximum dimension of from about 150 to about 1,000 microns;

2. said first ceramic aggregate, after being formed into a green body with a substantially circular-cross section and a diameter of 7 inches and being heated at a temperature of 1,225 degrees Centigrade for 1 hour, has a shrinkage of less than about 1.0 percent; and

3. all of the particles of said bonding agent are smaller than about 100 microns;

(b) adding from about 3 to about 6 weight percent of a binder to said mixture of ceramic aggregate and binding

agent, thereby producing a green body mixture;
(c) forming said green body mixture into a green body;
(d) subjecting said green body to a temperature of at least about 1,225 degrees Centigrade for at least about 1.0 hour, thereby producing a rigid body; and
(e) coating the top surface and the bottom surface of said rigid body with an aqueous slurry comprised of at least 40 weight percent of solid material, wherein:

1. said solid material is comprised of from about 80 to about 95 percent of a second ceramic aggregate material and from about 20 to about 5 percent of a second bonding agent; and
2. substantially all of the particles of said second ceramic aggregate material are smaller than about 150 microns.

14. The process as recited in claim 13, wherein said first ceramic aggregate consists essentially of alumina with a particle size distribution such that substantially all of its particles are larger than about 250 microns.

15. The process as recited in claim 14, wherein said second ceramic aggregate consists essentially of alumina with a particle size distribution such that substantially all of its particles are smaller than 125 microns.

16. The process as recited in claim 15, wherein said first bonding agent and said second bonding agent are substantially chemically identical.

17. The process as recited in claim 16, wherein said green body is subjected to a temperature of from about 1,225 to about 1,275 degrees Centigrade for at least about 8 hours.

18. The process as recited in claim 17, wherein said green body is formed by pressing.

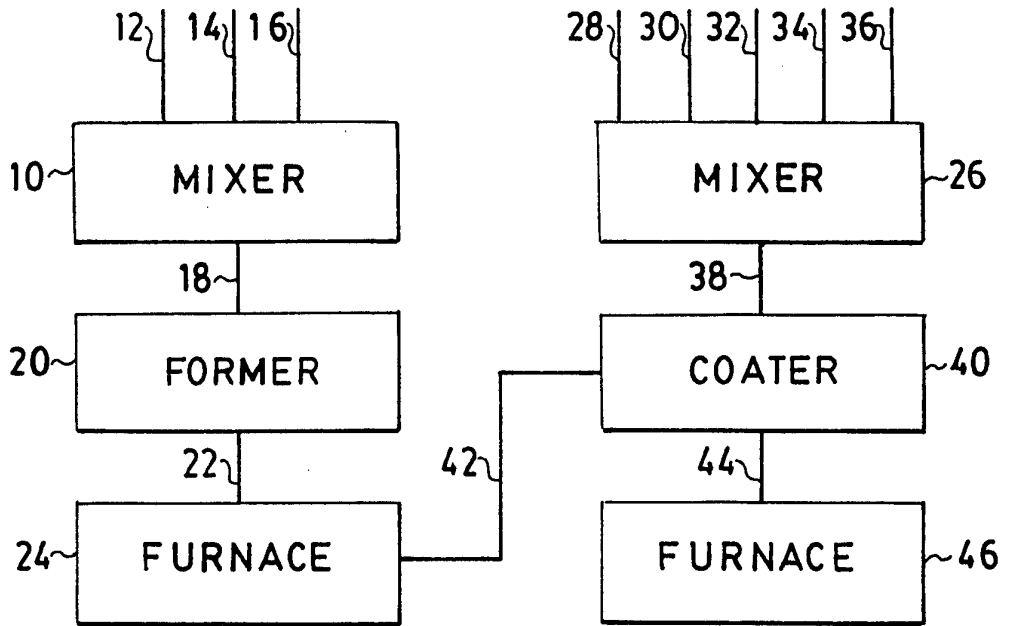

FIG. 1

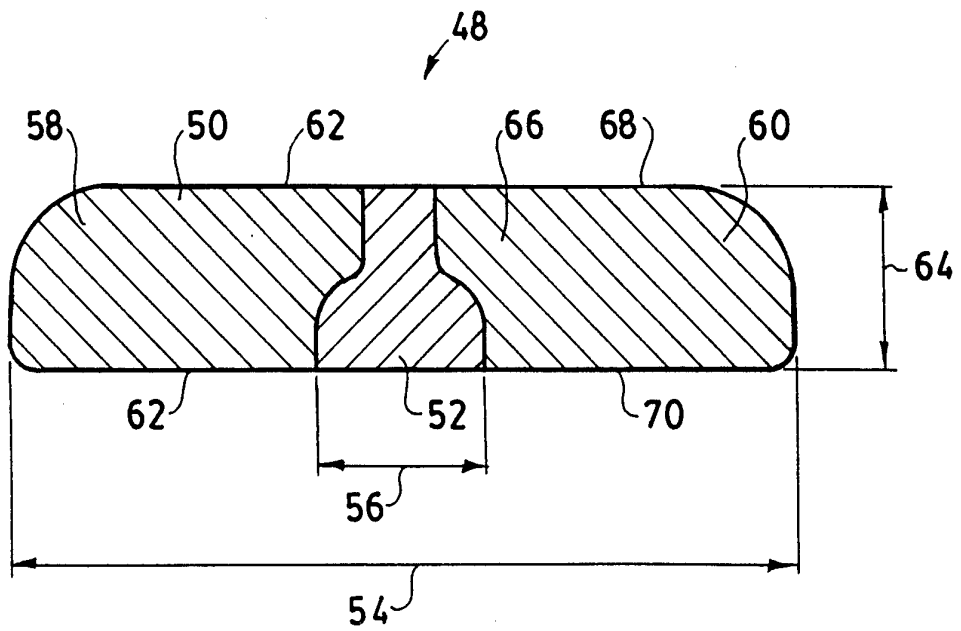

FIG. 2

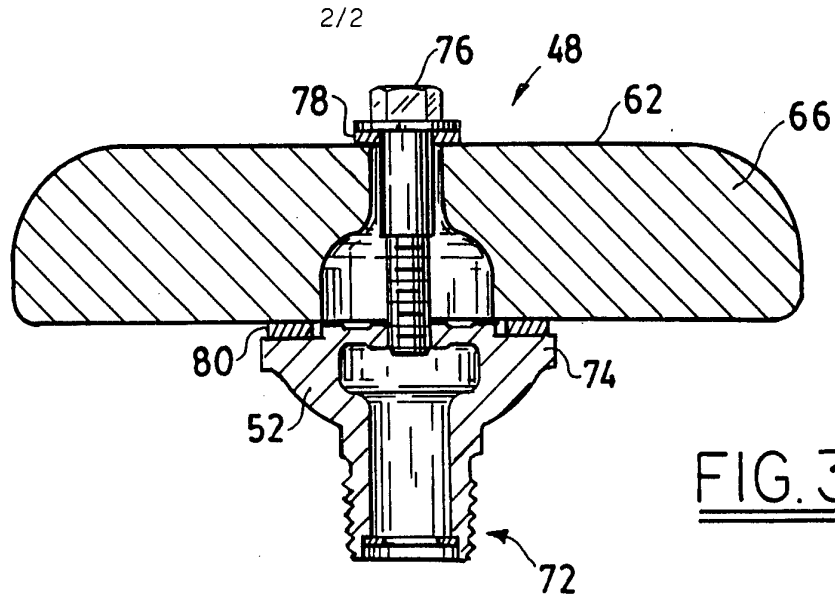

FIG. 3

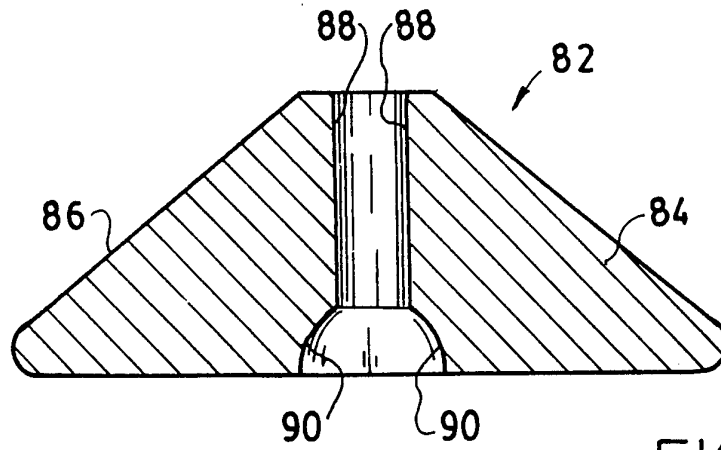

FIG. 4

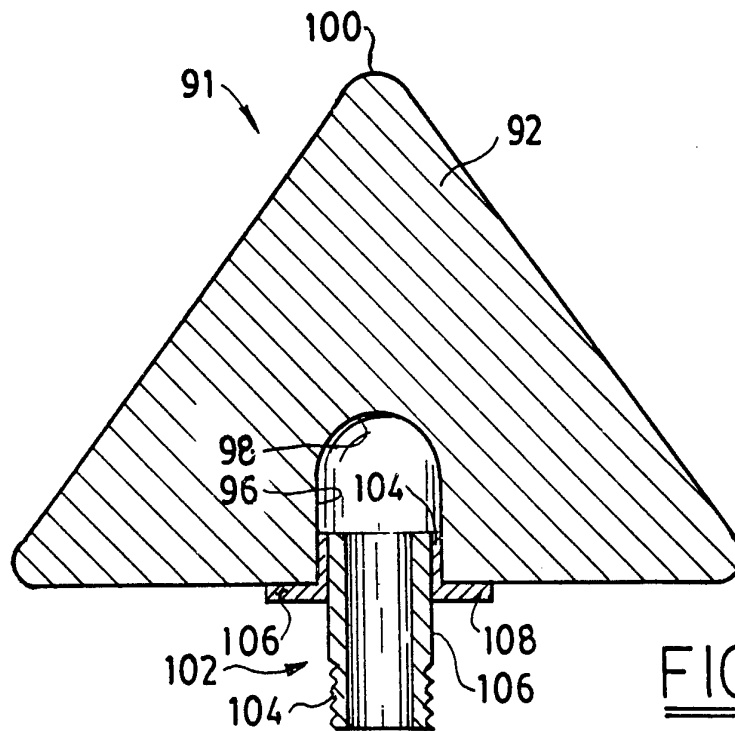

FIG. 5

INTERNATIONAL SEARCH REPORT

International application No.
PCT/US93/06923

A. CLASSIFICATION OF SUBJECT MATTER IPC(5) :BO1F3/04 US CL :261/122.1 According to International Patent Classification (IPC) or to both national classification and IPC		
B. FIELDS SEARCHED Minimum documentation searched (classification system followed by classification symbols) U.S. : 261/122.1, 501/80 Documentation searched other than minimum documentation to the extent that such documents are included in the fields searched Electronic data base consulted during the international search (name of data base and, where practicable, search terms used)		
C. DOCUMENTS CONSIDERED TO BE RELEVANT		
Category*	Citation of document, with indication, where appropriate, of the relevant passages	Relevant to claim No.
A	US,A, 3,507,253 (Willinger) 21 April 1990	1-18
A	US,A, 3,753,746 (Koerner) 21 August 1973	1-18
A	US,A, 4,820,412 (Meyer-Rudolphi) 11 April 1989	1-18
A	US,A, 4,046,845 (Veeder) 6 September 1977	1-18
A	US,A, 3,689,611 (Hardy et al) 5 September 1972	1-18
A	US,A, 4,184,885 (Pasco et al) 22 January 1980	1-18
A	US,A, 4,118,450 (Nakamura et al) 3 October 1978	1-18
<input checked="" type="checkbox"/> Further documents are listed in the continuation of Box C. <input type="checkbox"/> See patent family annex.		
* Special categories of cited documents: "A" document defining the general state of the art which is not considered to be part of particular relevance "E" earlier document published on or after the international filing date "L" document which may throw doubts on priority claim(s) or which is cited to establish the publication date of another citation or other special reason (as specified) "O" document referring to an oral disclosure, use, exhibition or other means "P" document published prior to the international filing date but later than the priority date claimed "T" later document published after the international filing date or priority date and not in conflict with the application but cited to understand the principle or theory underlying the invention "X" document of particular relevance; the claimed invention cannot be considered novel or cannot be considered to involve an inventive step when the document is taken alone "Y" document of particular relevance; the claimed invention cannot be considered to involve an inventive step when the document is combined with one or more other such documents, such combination being obvious to a person skilled in the art "&" document member of the same patent family		
Date of the actual completion of the international search 23 SEPTEMBER 1993		Date of mailing of the international search report 06 OCT 1993
Name and mailing address of the ISA/US Commissioner of Patents and Trademarks Box PCT Washington, D.C. 20231 Facsimile No. NOT APPLICABLE		Authorized officer TIM R. MILLES <i>Debbie Willian</i> Telephone No. (703) 308-3790

INTERNATIONAL SEARCH REPORT

International application No.
PCT/US93/06923

C (Continuation). DOCUMENTS CONSIDERED TO BE RELEVANT		
Category*	Citation of document, with indication, where appropriate, of the relevant passages	Relevant to claim No.
A	US,A, 4,746,341 (Komoda) 24 May 1988	1-18
A	US,A, 4,965,230 (Nakajima et al) 23 October 1990	1-18
A	US, A, 4,261,932 (Ewing et al) 14 April 1981	1-18