



US00D746382S

(12) **United States Design Patent**  
**Min**

(10) **Patent No.:** **US D746,382 S**

(45) **Date of Patent:** **\*\* Dec. 29, 2015**

- (54) **ELECTRIC VEHICLE FOR KIDS**
- (71) Applicant: **HENES CO., LTD.**, Gyeongsangnam-do (KR)
- (72) Inventor: **Kyung-Kyun Min**, Changwon-si (KR)
- (73) Assignee: **Henes Co., Ltd.** (KR)
- (\*\*) Term: **14 Years**

D483,812 S *	12/2003	Murkett .....	D21/433
D508,271 S *	8/2005	Augustin .....	D21/433
D524,876 S *	7/2006	Augustin .....	D21/433
D533,603 S *	12/2006	Chung .....	D21/433
D611,998 S *	3/2010	Pucci .....	D21/433
D632,344 S *	2/2011	Hong .....	D12/129
D720,815 S *	1/2015	Talios .....	D21/433

\* cited by examiner

*Primary Examiner* — Cynthia M Chin  
(74) *Attorney, Agent, or Firm* — Park & Associates IP Law, P. C.

- (21) Appl. No.: **29/500,333**
- (22) Filed: **Aug. 25, 2014**
- (51) **LOC (10) Cl.** ..... **21-01**
- (52) **U.S. Cl.**  
USPC ..... **D21/433**
- (58) **Field of Classification Search**  
USPC ..... D21/533, 548, 549, 550, 551, 561, 562, D21/433; D12/82, 86, 88, 89, 90, 91, 92, D12/93; 446/465, 468, 470, 471, 431, 446/454-456  
CPC ..... B60C 2200/20; B62B 5/0033  
See application file for complete search history.

(57) **CLAIM**  
The ornamental design for an electric vehicle for kids, as shown and described.

**DESCRIPTION**

FIG. 1 is a perspective view of an electric vehicle for kids in accordance with the new design,  
FIG. 2 is a front view of an electric vehicle for kids showing the new design;  
FIG. 3 is a rear view thereof;  
FIG. 4 is a right side view thereof;  
FIG. 5 is a left side view thereof;  
FIG. 6 is a top plan view thereof;  
FIG. 7 is a partial top plan view showing the dashboard and steering wheel of the vehicle in a disassembled state, with the display in an on state, shown separately for the ease and clarity of illustration; and,  
FIG. 8 is a bottom plan view thereof.

- (56) **References Cited**  
U.S. PATENT DOCUMENTS
- |              |         |               |         |
|--------------|---------|---------------|---------|
| D322,998 S * | 1/1992  | Harrod .....  | D21/433 |
| D402,332 S * | 12/1998 | Fichter ..... | D21/433 |
| D404,087 S * | 1/1999  | Larson .....  | D21/433 |
| D426,270 S * | 6/2000  | Rubau .....   | D21/433 |
| D432,185 S * | 10/2000 | Hulst .....   | D21/433 |
| D438,146 S * | 2/2001  | Larson .....  | D12/107 |

**1 Claim, 8 Drawing Sheets**



FIG. 1



FIG. 2



FIG. 3

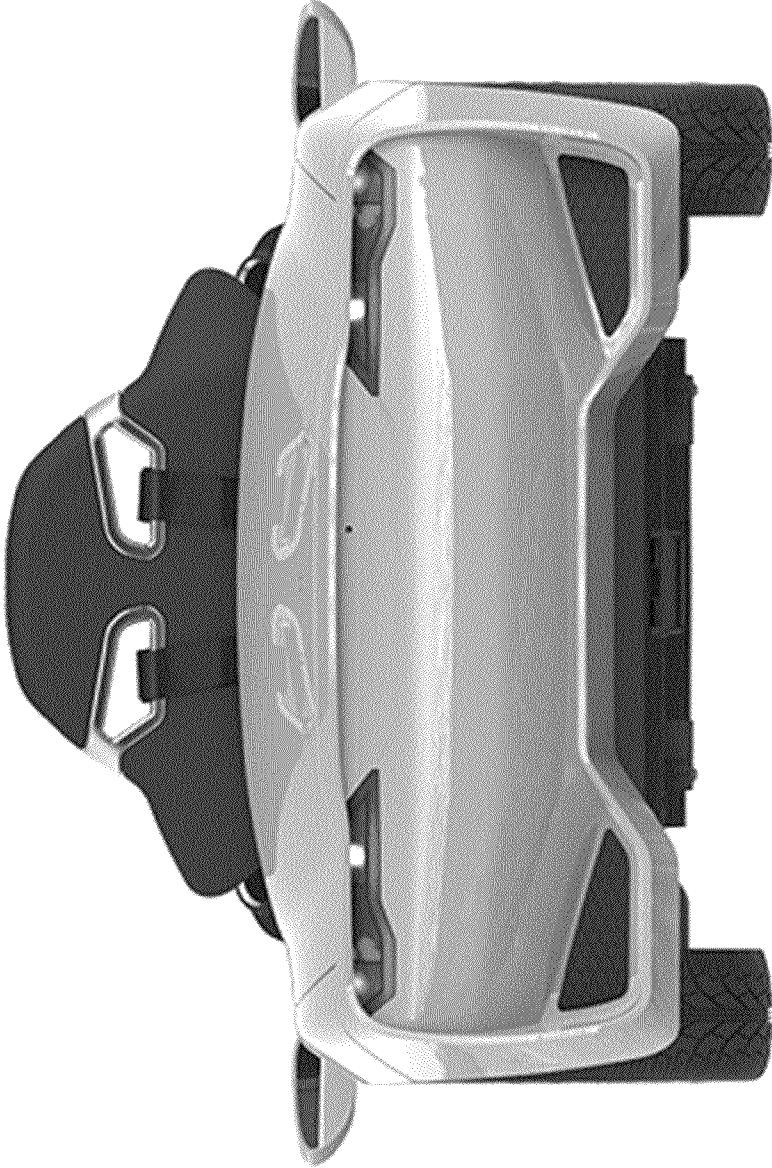



FIG. 4

FIG. 5



FIG. 6

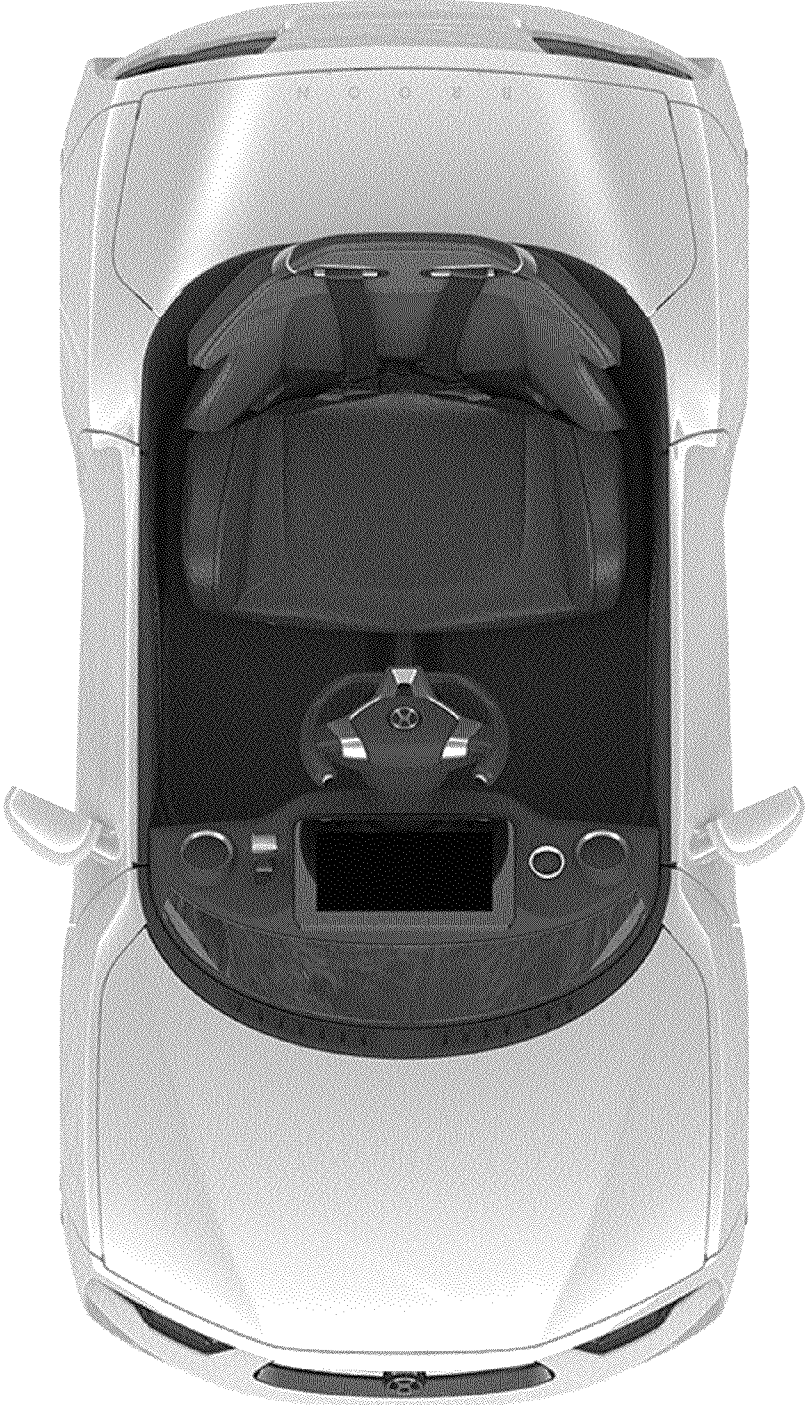

FIG. 7



FIG. 8

