



- (51) International Patent Classification:
A47L 15/42 (2006.01)
- (21) International Application Number:
PCT/IB2014/066953
- (22) International Filing Date:
16 December 2014 (16.12.2014)
- (25) Filing Language:
Italian
- (26) Publication Language:
English
- (30) Priority Data:
TO2013A001080 30 December 2013 (30.12.2013) IT
- (71) Applicant: INDESIT COMPANY S.P.A. [IT/IT]; Viale A. Merloni, 47, I-60044 Fabriano (AN) (IT).
- (72) Inventors: CORRIAS, Silvio; Str. Madonnina Sorine Levante 17, I-14036 Moncalvo (AT) (IT). PISTARINO, Marco; Via Nizza 342, I-10127 Torino (TO) (IT). ARVEDA, Diego; Via Dante Alighieri 5, I-10060 Piscina (TO) (IT).
- (74) Agent: SANTONICOLA, Paolo; Via Lamberto Corsi, 55, I-60044 Fabriano (AN) (IT).

- (81) Designated States (unless otherwise indicated, for every kind of national protection available): AE, AG, AL, AM, AO, AT, AU, AZ, BA, BB, BG, BH, BN, BR, BW, BY, BZ, CA, CH, CL, CN, CO, CR, CU, CZ, DE, DK, DM, DO, DZ, EC, EE, EG, ES, FI, GB, GD, GE, GH, GM, GT, HN, HR, HU, ID, IL, IN, IR, IS, JP, KE, KG, KN, KP, KR, KZ, LA, LC, LK, LR, LS, LU, LY, MA, MD, ME, MG, MK, MN, MW, MX, MY, MZ, NA, NG, NI, NO, NZ, OM, PA, PE, PG, PH, PL, PT, QA, RO, RS, RU, RW, SA, SC, SD, SE, SG, SK, SL, SM, ST, SV, SY, TH, TJ, TM, TN, TR, TT, TZ, UA, UG, US, UZ, VC, VN, ZA, ZM, ZW.
- (84) Designated States (unless otherwise indicated, for every kind of regional protection available): ARIPO (BW, GH, GM, KE, LR, LS, MW, MZ, NA, RW, SD, SL, ST, SZ, TZ, UG, ZM, ZW), Eurasian (AM, AZ, BY, KG, KZ, RU, TJ, TM), European (AL, AT, BE, BG, CH, CY, CZ, DE, DK, EE, ES, FI, FR, GB, GR, HR, HU, IE, IS, IT, LT, LU, LV, MC, MK, MT, NL, NO, PL, PT, RO, RS, SE, SI, SK, SM, TR), OAPI (BF, BJ, CF, CG, CI, CM, GA, GN, GQ, GW, KM, ML, MR, NE, SN, TD, TG).

Published:
— with international search report (Art. 21(3))

(54) Title: A DOOR ASSEMBLY FOR A DISHWASHING MACHINE, AND DISHWASHING MACHINE

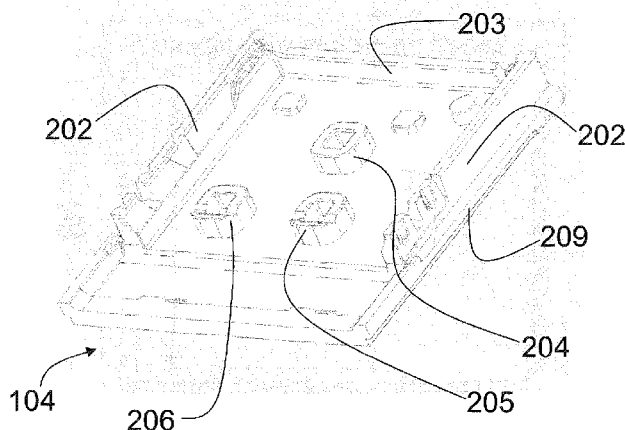

FIG. 2

(57) Abstract: The present invention relates to a door assembly (101) for a dishwashing machine, comprising: a door panel (102) adapted to face outwards from the dishwashing machine; a door back panel (103) adapted to face towards the inside of the dishwashing machine; wherein said door panel (102) and door back panel (103) are mutually adapted to be coupled together to form a shell-like structure, and further comprising: a stiffening panel (104) made of foam material inserted in the shell-like structure; the door assembly (101) comprises at least one area of mechanical interference (202, 204, 205, 206, 209) between the stiffening panel (104) and the door back panel (103) and/or preferably, the door panel (102) and/or preferably the means (106) for connecting the door assembly (101) to the dishwashing machine structure. Furthermore, the present invention refers to the dishwashing machine related thereto.



A DOOR ASSEMBLY FOR A DISHWASHING MACHINE, AND DISHWASHING
MACHINE

DESCRIPTION

[TECHNICAL FIELD]

5 The present invention refers to a door assembly for a
dishwashing machine, and related dishwashing machine
preferably of a "freestanding" type.

[PRIOR ART]

Current dishwashing machines comprise a front door for
10 loading dishes to wash; said door typically comprise hinged
connection means on the door's lower side connecting said
door to its articulation, and a handle on its upper side.
Known dishwashers' doors, therefore, during opening and
closing are subjected to flexion stress induced by the force
15 that is applied by the user opening or closing said door, and
increased by possible door misalignment which leads to strong
stress being locally exerted on mechanical connection
elements.

Dishwashers' doors require, therefore, enough
20 mechanical stiffness to withstand said external stresses,
especially when being opened and closed. At the same time,
dishwashers' doors must be lightweight, so as to be easy to

handle for users during opening and closing.

Such requirements are, therefore, in contrast with one another: known dishwashers' doors can turn out to be excessively heavy, though stiff, thus causing difficult, laborious operation by users; other known dishwashers' doors can be lightweight but poorly stiff, thus possibly leading to their breaking.

[OBJECTS AND SUMMARY OF THE INVENTION]

An object of the present invention is to provide a door assembly for a dishwashing machine that solves some of the problems affecting prior art.

In particular, it is an object of the present invention to provide a door assembly for a dishwashing machine that is stiff and that enables to realise a door with enhanced robustness.

It is another object of the present invention to provide a door assembly for a dishwashing machine that can withstand the stress applied to the door during opening and closing for the entire product's useful life.

In particular, an object of the present invention is to achieve a door assembly that stands out amongst known technical solutions for its apparent higher resistance to

torsion stress tending to create an angle between the plane of the door assembly and the plane of the aperture to be closed by said door assembly (said angle being an unwanted feature as it causes a twist of the door assembly whereby one of the two lateral edges becomes closer to the abovementioned aperture than its contralateral edge).

Furthermore, it is an object of the present invention to provide a door assembly for a dishwashing machine that is lightweight, and allows to realise a door whose opening by users is performed more easily.

Lastly, it is an object of the present invention to provide a door assembly for a dishwashing machine that is easy and quick to build and assemble.

These and other objects are achieved by means of a door assembly for a dishwashing machine and related dishwashing machine, according to the claims appended hereto forming an integral part of this description.

An idea underlying the present invention is to provide a door assembly for a dishwashing machine comprising: a door panel adapted to face outwards from the dishwashing machine; a door back panel adapted to face towards the inside of the dishwashing machine; wherein said door panel and door back

panel are mutually adapted to be coupled together to form a shell-like structure and further comprising: a stiffening panel made of foam material inserted in the shell-like structure; the door assembly comprises at least one area of mechanical interference between the stiffening panel and the door back panel.

An advantageous embodiment of the door assembly comprises a plurality of interference areas between the stiffening panel and the door back panel and/or the door panel and/or the connection means (106), typically hinges, that connect the door assembly (101) to the dishwashing machine's structure. This solution allows to realise a door assembly for a dishwashing machine that is stiffer and better suited to withstand the stress applied to the door during its opening and closing.

Furthermore, the use of a foam material stiffening panel enables to realise a door assembly for a dishwashing machine that is lightweight, so that its door can be more comfortably opened by users.

The door assembly according to said solution also comprises a reduced number of components, that can be easily realised and assembled, thus providing further advantages to

its industrial scale manufacturing.

Further particular and advantageous features will become more apparent from the detailed description following hereunder, as well as from the claims relating thereto.

5 **[BRIEF DESCRIPTION OF THE DRAWINGS]**

Some examples of preferred and advantageous embodiments are hereby described by way of example and not by way of limitation, with reference to the figures attached, where:

10 - Figure 1 is an exploded view of an embodiment of the door assembly for a dishwashing machine according to the present invention.

- Figure 2 shows in more details the stiffening panel of an embodiment of the present invention.

15 - Figure 3 provides a front view (a) of the door assembly of Figure 1 from the inside of the dishwashing machine, and a couple of cross-sections (b) and (c) of the door assembly of Figure 1, in assembled state.

20 The Figures show different aspects and embodiments of the present invention and, where appropriate, structures, components, materials and/or similar elements in different figures are indicated with the same reference numbers.

[DETAILED DESCRIPTION OF THE INVENTION]

Figure 1 shows an embodiment of the door assembly 101 for a dishwashing machine. Said door assembly 101 is preferably realised for a dishwashing machine of the "freestanding" type, that is to say comprising a door on
5 which no further finishing coverage is applied to match with kitchen cabinetry. Indeed, said "freestanding" dishwashers feature doors that are less stiff due to no finishing panel being applied onto them, and they can, therefore, benefit more from the advantages provided by the present invention.
10 However, the present invention is also applicable to built-in dishwashing machines.

The door assembly 101 comprises a door panel 102 adapted to face outwards from the dishwashing machine, and a door back panel 103 adapted to face towards the inside of the
15 dishwashing machine.

Said door panel 102 and door back panel 103 are mutually adapted to be coupled together to form the shell-like structure shown in its assembled configuration in Figure 3.

In a preferred embodiment the door back panel 103 is
20 made

of sheet metal, preferably having a thickness of approximately 0.35 mm.

In a preferred embodiment the door panel 102 is made of sheet metal, preferably having a thickness of approximately 0.6 mm.

The door assembly 101 further comprises a stiffening panel 104 made of foam material, inserted in the above-described shell-like structure. Said stiffening panel contributes to creating in the door assembly 101 at least one area of mechanical interference between the stiffening panel 104 and the door back panel 103. Indeed, said mechanical interference areas allow the door assembly to be stiffer, thanks to the addition of foam material to its structure, as said foam material replicates the shape of the elements it is adjoined to, thus abutting onto them. This way, the structure is made more rigid by giving it a monolith-like resistance, less subjected to flexion when the door is opened or closed, thus less subjected to misalignment that may be detrimental to its resistance.

The stiffening panel 104 is preferably made of sintered polystyrene foam (also known as EPS, or simply Polystyrene), and preferably obtained from moulding with no mechanical processes

like cutting or material removal. Said stiffening panel

104 has a preferred thickness ranging from 23 mm to 28 mm.

Preferably, the door assembly 101 further comprises a sound-absorbing panel 105 inserted between the door back panel 103 and the stiffening panel 104. Preferably, the sound-
5 absorbing panel 105 is made of recycled cotton with heat-hardened binding agent, and is preferably about 18 mm thick.

Preferably, the door assembly 101 further comprises means 106 for connection to the dishwashing machine structure, comprising in particular a plurality of hinges where the
10 stiffening panel 104 can create a further mechanical interference area. Said further interference area between the stiffening panel 104 and the connecting means 106 turns out to bring about significant advantages in that it grants the door assembly 101 remarkable stiffness and remarkable stability in
15 particular during opening and closing.

Moreover, preferably, the door assembly 101 can further comprise gluing between at least said door panel 102 and the external surface of said stiffening panel 104, so as to reduce possible creaking noises from the stiffening panel 104.

20 Figure 2 shows the stiffening panel 104 in more details.

Preferably, the stiffening panel 104 comprises a plurality of lateral protrusions 202 and an upper protrusion

203, made respectively in the stiffening panel's lateral areas 104 or in the stiffening panel 104 upper portion, where the door handle is typically found.

Preferably, the door back panel 103 comprises a
5 respective plurality of lateral profiles adapted to abut on
said lateral protrusions 202, as better shown in Figure 3. It
is right in the area where lateral protrusions 202 abut on the
lateral protrusions of the door back panel 103, that a lateral
interference area is created. Upper protrusion 203 is instead
10 used for relieving stress laterally as well as to grant more
structural rigidity to panel 104 in the area where stresses
are higher (indeed, it is an area located approximately as
high as the door handle on door panel 102), without
implementing any other connecting function by means of
15 interference.

Preferably, said stiffening panel 104 comprises a
plurality of central protrusions 204, 205, 206 adapted to abut
against said door back panel 103 to create a second area of
central interference with said door back panel 103.

20 Preferably, central protrusions are provided in a number
which is equal or higher than three, yet more preferably
exactly equal to three and located at the vertices of a

triangle. This way, it is possible to optimally relieve the pressure generated by the areas of interference on the door back panel 103.

Preferably, said central protrusions 204, 205, 206
5 comprise a substantially cylindrical structure. In an advantageous embodiment, lateral protrusions are at least partially hollow internally, so as to save on materials and make the stiffening panel 104 lighter.

In particular, central protrusions 205,206 further
10 comprise a cavity adapted to allow the passage of a wire harness or a mechanical element being substantially horizontal in said door. In particular, said recesses are suitable to allow the passing of a wire harness or a pipe.

In general, said stiffening panel 104 contributes both
15 to making the door assembly more mechanically resistant, and to keeping in place wiring harnesses and other ancillary elements that may be found in said door.

In general, mechanical interference areas contribute to
20 eliminating backlashes between said door panel 102 and door back panel 103 in a widespread manner e.g., lateral protrusions 202 as well as in a localized manner e.g., central

protrusions 204, 205 and 206.

Furthermore, mechanical interference areas, in particular at the hinges, contribute to stiffening the door during opening and closing, so that the entire door assembly
5 undergoes less deformation, thus increasing user-friendliness and reliability.

In an advantageous embodiment, further coupling with mechanical interference can be provided between said stiffening panel 104 and said door panel 102 also in lateral
10 areas 209 in favour of the door assembly's increased stiffness.

Figure 3 provides a front view (a) of said door assembly 101 and a couple of cross sections (b) and (c) of the door assembly shown in Figure 1, in an assembled state.

15 The recess that is visible in the front view (a) is preferably used to accommodate functional devices for the machines e.g., a washing liquid dispenser.

Considering the description of the present invention related to preferred and advantageous embodiments, it is
20 apparent to the person skilled in the art that further modifications and variants of the invention are possible.

For example, the stiffening panel can be made of any

suitable foam material, having a higher or lower specific weight and different mechanical features.

CLAIMS

1. A door assembly (101) for a dishwashing machine,
comprising:
a door panel (102) adapted to face outwards from the
5 dishwashing machine;
a door back panel (103) adapted to face towards the inside
of the dishwashing machine;
wherein said door panel (102) and said door back panel
(103) are mutually adapted to be coupled together to
10 create a shell-like structure,
characterized in that said door assembly (101) further
comprises:
a stiffening panel (104) made of foam material, inserted in
said shell-like structure;
15 at least one area of mechanical interference (202, 204,
205, 206) between said stiffening panel (104) and said
door back panel (103).
2. A door assembly (101) according to claim 1, wherein said
stiffening panel (104) comprises a plurality of lateral
20 protrusions (202), and wherein said door back panel (103)
comprises a respective plurality of lateral profiles
adapted to match said lateral protrusions (202), wherein

said door

assembly (101) comprises a first area of lateral interference between said lateral protrusions (202) and said lateral profiles.

- 5 3. A door assembly (101) according to claim 2, wherein said stiffening panel (104) comprises a plurality of central protrusions (204, 205, 206) adapted to abut against said door back panel (103) to create a second area of central interference with said door back panel (103).
- 10 4. A door assembly (101) according to claim 3, wherein said central protrusions (204, 205, 206) comprise a substantially cylindrical structure which is at least partially hollow internally.
5. A door assembly (101) according to claim 4, wherein said
15 substantially cylindrical structure further comprises a cavity adapted to allow the passage of a wire harness or a mechanical element, said cavity being preferably substantially horizontal in said door.
6. A door assembly (101) according to any one of claims 1 to
20 5, wherein said stiffening panel (104) is made of sintered expanded polystyrene, preferably obtained by moulding.

7. A door assembly according to any one of claims 1 to 6, further comprising connecting means (106), in particular hinges, adapted to connect said door assembly (101) to a dishwashing machine, wherein a further area of mechanical interference (202) is created between said stiffening panel (104) and said connecting means (106).
8. A door assembly according to any one of claims 1 to 7, further comprising an additional area of lateral mechanical interference (209) between said door panel (102) and said stiffening panel (104), and preferably a gluing at least between said door panel (102) and said stiffening panel (104).
9. A door assembly according to any one of claims 1 to 8, further comprising a sound-absorbing panel (105) inserted between said door back panel (103) and said stiffening panel (104).
10. A dishwashing machine comprising a door assembly (101) according to any one of claims 1 to 9.

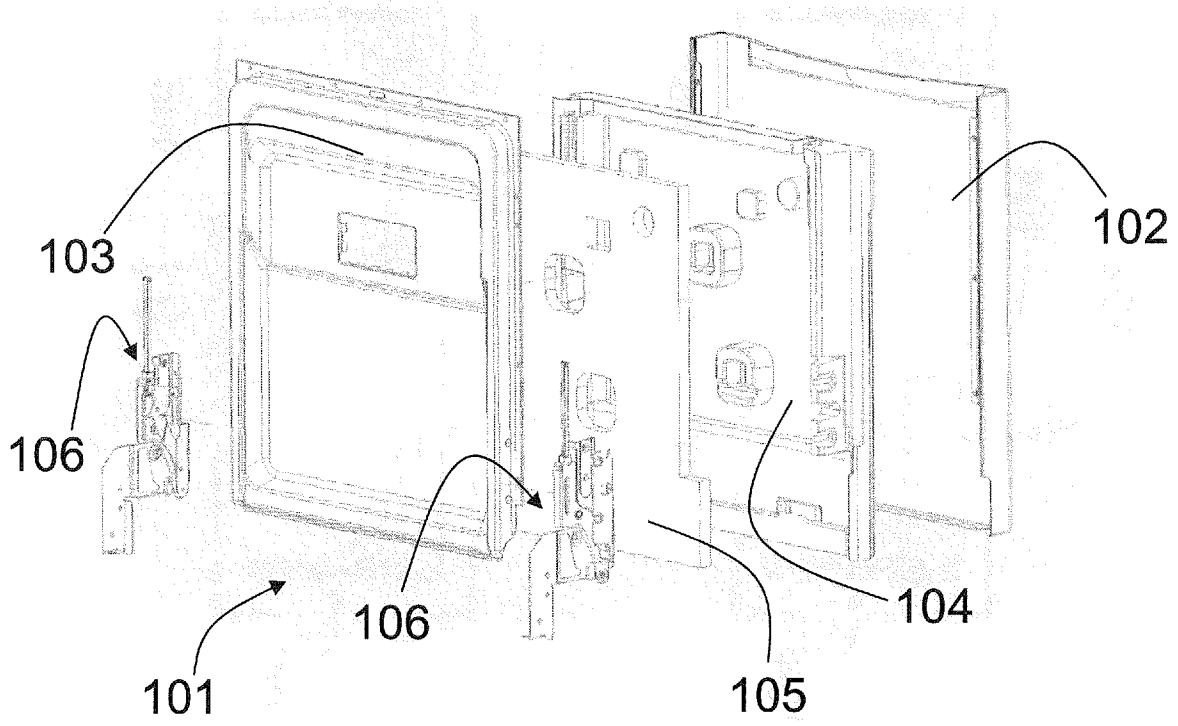

FIG. 1

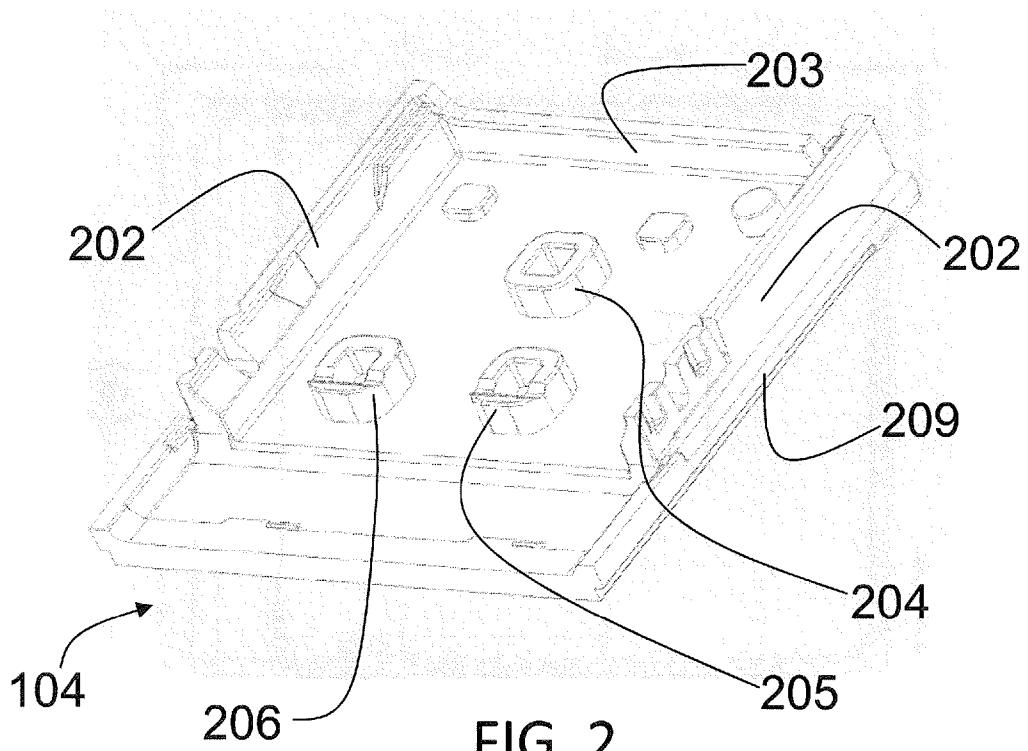

FIG. 2

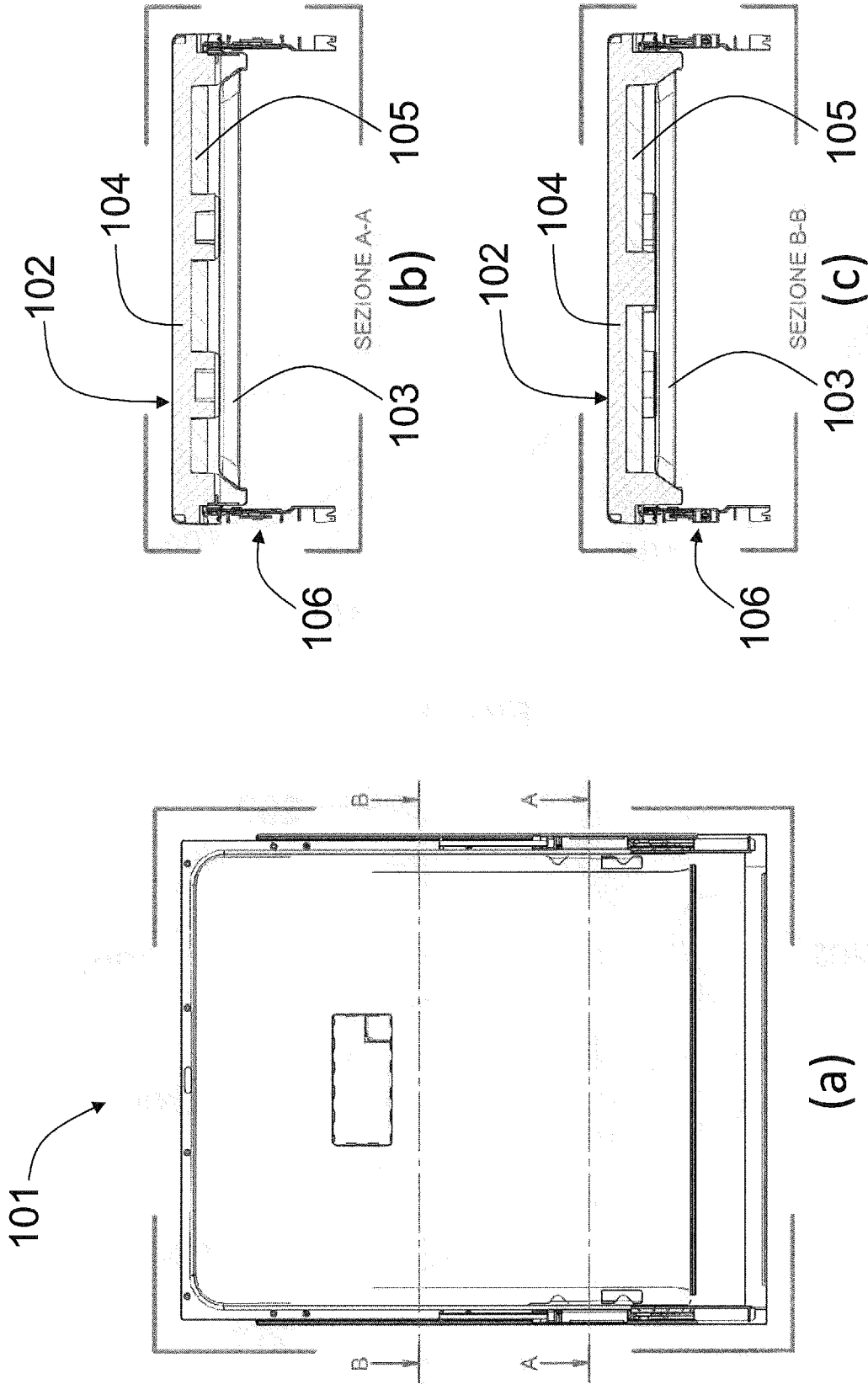

FIG. 3

INTERNATIONAL SEARCH REPORT

International application No
PCT/IB2014/066953

A. CLASSIFICATION OF SUBJECT MATTER
INV. A47L15/42
ADD.

According to International Patent Classification (IPC) or to both national classification and IPC

B. FIELDS SEARCHED
Minimum documentation searched (classification system followed by classification symbols)
A47L E04B B60R

Documentation searched other than minimum documentation to the extent that such documents are included in the fields searched

Electronic data base consulted during the international search (name of data base and, where practicable, search terms used)
EPO-Internal, WPI Data

C. DOCUMENTS CONSIDERED TO BE RELEVANT		
Category*	Citation of document, with indication, where appropriate, of the relevant passages	Relevant to claim No.
X	US 2010/180916 A1 (COLON MARIO ASCANDER [US] ET AL) 22 July 2010 (2010-07-22) page 2, paragraph 19 page 3, paragraph 23 - paragraph 24; figure 3	1-10
A	----- US 2010/148644 A1 (POYNER DENNIS A [US] ET AL) 17 June 2010 (2010-06-17) page 2, paragraph 19 - paragraph 22; figures 3A, 3B	1-10
A	----- EP 1 522 250 A2 (DIEHL AKO STIFTUNG GMBH & CO [DE]) 13 April 2005 (2005-04-13) column 1, paragraph 5 column 3, paragraph 14; figure 2 ----- -/--	1-10

Further documents are listed in the continuation of Box C.

See patent family annex.

* Special categories of cited documents :

- "A" document defining the general state of the art which is not considered to be of particular relevance
- "E" earlier application or patent but published on or after the international filing date
- "L" document which may throw doubts on priority claim(s) or which is cited to establish the publication date of another citation or other special reason (as specified)
- "O" document referring to an oral disclosure, use, exhibition or other means
- "P" document published prior to the international filing date but later than the priority date claimed

"T" later document published after the international filing date or priority date and not in conflict with the application but cited to understand the principle or theory underlying the invention

"X" document of particular relevance; the claimed invention cannot be considered novel or cannot be considered to involve an inventive step when the document is taken alone

"Y" document of particular relevance; the claimed invention cannot be considered to involve an inventive step when the document is combined with one or more other such documents, such combination being obvious to a person skilled in the art

"&" document member of the same patent family

Date of the actual completion of the international search 23 February 2015	Date of mailing of the international search report 04/03/2015
Name and mailing address of the ISA/ European Patent Office, P.B. 5818 Patentlaan 2 NL - 2280 HV Rijswijk Tel. (+31-70) 340-2040, Fax: (+31-70) 340-3016	Authorized officer Lodato, Alessandra

INTERNATIONAL SEARCH REPORT

International application No
PCT/IB2014/066953

C(Continuation). DOCUMENTS CONSIDERED TO BE RELEVANT		
Category*	Citation of document, with indication, where appropriate, of the relevant passages	Relevant to claim No.
A	US 2009/320892 A1 (POYNER DENNIS A [US] ET AL) 31 December 2009 (2009-12-31) page 2, paragraph 26 - page 3, paragraph 30; figure 3 -----	1-10
A	US 2013/234574 A1 (FISCHER MARCUS R [US] ET AL) 12 September 2013 (2013-09-12) page 2, paragraph 19 - page 3, paragraph 25; figure 4 -----	1-10

INTERNATIONAL SEARCH REPORT

Information on patent family members

International application No

PCT/IB2014/066953

Patent document cited in search report	Publication date	Patent family member(s)	Publication date
US 2010180916	A1	22-07-2010	
		AU 2010206948 A1	18-08-2011
		CA 2749980 A1	29-07-2010
		CN 102341027 A	01-02-2012
		EP 2391256 A2	07-12-2011
		KR 20110124240 A	16-11-2011
		RU 2011131703 A	27-03-2013
		US 2010180916 A1	22-07-2010
		WO 2010085422 A2	29-07-2010

US 2010148644	A1	17-06-2010	NONE

EP 1522250	A2	13-04-2005	
		DE 10347808 A1	12-05-2005
		EP 1522250 A2	13-04-2005
		US 2005079739 A1	14-04-2005

US 2009320892	A1	31-12-2009	
		CN 102076258 A	25-05-2011
		EP 2303090 A1	06-04-2011
		US 2009320892 A1	31-12-2009
		WO 2010002843 A1	07-01-2010

US 2013234574	A1	12-09-2013	NONE
