

(12) INTERNATIONAL APPLICATION PUBLISHED UNDER THE PATENT COOPERATION TREATY (PCT)

(19) World Intellectual Property
Organization

International Bureau

(43) International Publication Date
20 April 2023 (20.04.2023)



(10) International Publication Number
WO 2023/062513 A1

(51) International Patent Classification:

A01G 9/02 (2018.01)

Published:

— with international search report (Art. 21(3))

(21) International Application Number:

PCT/IB2022/059711

(22) International Filing Date:

11 October 2022 (11.10.2022)

(25) Filing Language:

English

(26) Publication Language:

English

(30) Priority Data:

202121046149 11 October 2021 (11.10.2021) IN

(72) Inventor; and

(71) Applicant: **SHAH, Sujay Ashvin** [IN/IN]; 2403, Pearl Residency, Opp. Honda Showroom, Sayani, Road, Prabhadevi, Mumbai-, Maharashtra 400025 (IN).

(74) Agent: **DEWAN, Mohan**; R. K. Dewan & Co. Podar Chambers, S. A. Brelvi Road, Fort, Mumbai-, Maharashtra 400001 (IN).

(81) Designated States (unless otherwise indicated, for every kind of national protection available): AE, AG, AL, AM, AO, AT, AU, AZ, BA, BB, BG, BH, BN, BR, BW, BY, BZ, CA, CH, CL, CN, CO, CR, CU, CV, CZ, DE, DJ, DK, DM, DO, DZ, EC, EE, EG, ES, FI, GB, GD, GE, GH, GM, GT, HN, HR, HU, ID, IL, IN, IQ, IR, IS, IT, JM, JO, JP, KE, KG, KH, KN, KP, KR, KW, KZ, LA, LC, LK, LR, LS, LU, LY, MA, MD, MG, MK, MN, MW, MX, MY, MZ, NA, NG, NI, NO, NZ, OM, PA, PE, PG, PH, PL, PT, QA, RO, RS, RU, RW, SA, SC, SD, SE, SG, SK, SL, ST, SV, SY, TH, TJ, TM, TN, TR, TT, TZ, UA, UG, US, UZ, VC, VN, WS, ZA, ZM, ZW.

(84) Designated States (unless otherwise indicated, for every kind of regional protection available): ARIPO (BW, GH, GM, KE, LR, LS, MW, MZ, NA, RW, SD, SL, ST, SZ, TZ, UG, ZM, ZW), Eurasian (AM, AZ, BY, KG, KZ, RU, TJ, TM), European (AL, AT, BE, BG, CH, CY, CZ, DE, DK, EE, ES, FI, FR, GB, GR, HR, HU, IE, IS, IT, LT, LU, LV, MC, ME, MK, MT, NL, NO, PL, PT, RO, RS, SE, SI, SK, SM, TR), OAPI (BF, BJ, CF, CG, CI, CM, GA, GN, GQ, GW, KM, ML, MR, NE, SN, TD, TG).

Declarations under Rule 4.17:

- as to the identity of the inventor (Rule 4.17(i))
- of inventorship (Rule 4.17(iv))

(54) Title: A VERTICAL LAWN

(57) Abstract: The present disclosure relates to vertical gardens. The present disclosure envisages a vertical lawn (100). The vertical lawn (100) comprises an artificial substrate (140), a water-proofing layer applied on the substrate (140), and a drainage sheet (105) provided on the water-proofing layer. The drainage sheet (105) has a plurality of projections (107) configured thereon to facilitate flow of water therebetween. A geotextile sheet (106) is fitted on an operative front surface of the drainage sheet (105). A hydrophilic rock mineral wool layer (110) is secured to the operative front surface of the geotextile sheet (106). The rock mineral wool layer (110) configured to absorb and retain moisture therein. A lawn mat secured to the rock mineral wool layer (110).



WO 2023/062513 A1

A VERTICAL LAWN

FIELD

The present invention relates to vertical gardens.

DEFINITION

As used in the present disclosure, the following terms are generally intended to have the
5 meaning as set forth below, except to the extent that the context in which they are used
indicate otherwise.

Lawn: The term 'lawn' herein the specification refers to continuous series of grass, sedums,
ground covers, and plants including succulents, hydroponics or flowering plants.

Grass mat: The term 'grass mat' herein the specification refers to natural grass grown from
grass seeds on soil. The grass mat can be rectangular pieces or rolls of grass from which they
could be cut.

Vertical: The term 'vertical' herein the specification refers to an inclined angle ranging from
45° to 120° with respect to the ground.

BACKGROUND

The background information herein below relates to the present disclosure but is not
necessarily prior art.

Vertical gardens are series of vegetation such as grass, or plants such as succulents or
10 hydroponics grown in bags, planters or cups that are vertically suspended on walls for
beautifying spaces with limited surface area. The bags, planters or cups are discrete elements
requiring separate frames, and hitherto without their help the grass or the plants cannot be
grown at any inclined angle.

The biggest disadvantage of a vertical garden is that moisture from the bags or the planters seep
15 on to the walls on which they are supported, and cause rotting of the wall if not installed
properly. Further, excess water from the garden tend to stain or dirty the walls and the
surrounding areas.

There is therefore felt a need for a vertical garden that alleviates the aforementioned drawbacks.

OBJECTS

Some of the objects of the present disclosure, which at least one embodiment herein satisfies, are as follows:

An object of the present disclosure is to provide a vertical lawn.

- 5 Another object of the present disclosure is to provide a vertical lawn which adds to the aesthetic appeal of spaces.

Yet another object of the present disclosure is to provide a vertical lawn which allows draining of water therefrom, without affecting walls on which they are supported.

- 10 Other objects and advantages of the present disclosure will be more apparent from the following description, which is not intended to limit the scope of the present disclosure.

SUMMARY

The vertical lawn comprises an artificial substrate, a water-proofing layer applied on the substrate, and a drainage sheet provided on the water-proofing layer. The drainage sheet has a plurality of projections configured thereon to facilitate flow of water between the projections.

- 15 A geotextile sheet is fitted on an operative front surface of the drainage sheet. A hydrophilic rock mineral wool layer is secured to the operative front surface of the geotextile sheet. The rock mineral wool layer configured to absorb and retain moisture therein. A lawn mat secured to the rock mineral wool layer.

BRIEF DESCRIPTION OF THE ACCOMPANYING DRAWING

- 20 A vertical lawn, of the present disclosure will now be described with the help of the accompanying drawing, in which:

Figure 1A illustrates a cross-sectional side view of the lawn mounted on a wall at a vertical axis, in accordance to an aspect of the present disclosure;

- 25 **Figure 1B** illustrates another cross-sectional side view of the lawn mounted on a wall at an inclined axis;

Figure 2A and Figure 2B illustrates an operative front view of the lawn of Figure 1;

Figure 3 illustrates an operative front view of a drainage sheet of the lawn, of Figure 1; and

Figure 4 illustrates a cross-sectional side view of the lawn, of Figure 1A, provided with a bracket.

LIST OF REFERENCE NUMERALS

	100	vertical lawn
5	105	drainage sheet
	106	geotextile sheet
	107	projection
	110	rock mineral wool layer
	115	lawn mat
10	117	grass layer
	125	strip fitment
	127	bracket
	130	bolt
	140	substrate
15	142	brace
	143	base of the brace
	144	first arm of the brace
	145	intermediate arm of the brace
	146	perforations on the intermediate arm of the brace
20	X	angle of the vertical lawn from the horizontal

DETAILED DESCRIPTION

Embodiments, of the present disclosure, will now be described with reference to the accompanying drawing.

Embodiments are provided so as to thoroughly and fully convey the scope of the present disclosure to the person skilled in the art. Numerous details are set forth, relating to specific components, and methods, to provide a complete understanding of embodiments of the present disclosure. It will be apparent to the person skilled in the art that the details provided
5 in the embodiments should not be construed to limit the scope of the present disclosure. In some embodiments, well-known processes, well-known apparatus structures, and well-known techniques are not described in detail.

The terminology used, in the present disclosure, is only for the purpose of explaining a particular embodiment and such terminology shall not be considered to limit the scope of the
10 present disclosure. As used in the present disclosure, the forms “a”, “an” and “the” may be intended to include the plural forms as well, unless the context clearly suggests otherwise. The terms “comprises”, “comprising”, “including”, “includes” and “having” are open-ended transitional phrases and therefore specify the presence of stated features, elements, modules, units and/or components, but do not forbid the presence or addition of one or more other
15 features, elements, components, and/or groups thereof.

A vertical lawn (100), of the present disclosure, will now be described with reference to Figure 1A through Figure 4.

The vertical lawn (100) comprises an artificial substrate (140), a water-proofing layer applied on the substrate (140), and a drainage sheet (105) provided on the water-proofing layer (not
20 specifically labelled in Figures). The drainage sheet (105) has a plurality of projections (107) configured thereon to facilitate flow of water between the projections (107). A geotextile sheet (106) is fitted on an operative front surface of the drainage sheet (105). A hydrophilic rock mineral wool layer (110) is secured to the operative front surface of the geotextile sheet (106). The rock mineral wool layer (110) configured to absorb and retain moisture therein. A
25 lawn mat (115) secured to the rock mineral wool layer (110).

The vertical lawn (100) includes a lawn mat (115) having a grass layer (117) grown thereon. The grass layer could be substituted by plants such as succulents, or hydroponics or herbs. The lawn mat (115) is mounted on a rock mineral wool layer (110).

In an embodiment, the vertical lawn (100) is configured to incline at an angle ranging
30 between 45° to 120° with respect to the ground, as shown in Figures 1A through Figure1C. In

another embodiment, the vertical lawn (100) is configured to incline at an angle of 90° with respect to the ground, as particularly seen in Figure 1A.

In yet another embodiment, the artificial substrate (140) is an inclined wall.

5 In one embodiment, the water-proofing layer is a layer of natural water-repellant material, or a layer of synthetic water-repellant material.

In an embodiment, the water-proofing layer is a water-repellent sheet. In another embodiment, the water-proofing layer is a liquid water-repellent applied on the substrate (140) in coats.

10 In yet another embodiment, the water-proofing layer is selected from the group consisting of elastomeric material, cementitious material, latex, acrylic, polyurethane or a combination thereof.

In still another embodiment, the thickness of the water-proofing layer ranges between 100 microns to 2000 microns.

15 In an embodiment, the projections (107) are configured on an operative front surface of the drainage sheet (105). In another embodiment, the projections (107) are configured on both operative front surface and operative back surface of the drainage sheet (105).

In an embodiment, the projections (107) are configured on the drainage sheet (105) in a staggered configuration, as shown in Figure 3, to define space between each projection (107).

20 In another embodiment, each of the projections (107) has a configuration selected from the group consisting of cup-shaped configuration, trapezoidal configuration, and dimpled configuration.

In yet another embodiment, the projection (107) as a shape selected from the group consisting of circular, elliptical, ovular, rectangular, and octagonal. In still another embodiment, the height of each projection (107) varies between 4mm to 25mm.

25 In an embodiment, the drainage sheet (105) is of a material selected from the group consisting of low density polyethylene (LDPE), high density polyethylene (HDPE), polypropylene, polyolefins, polyvinyl chloride, polyesters, polystyrene, recycled polymers, composites or a combination thereof.

In another embodiment, the thickness of the drainage sheet (105) ranges between 0.5mm to 1.5mm.

The geotextile sheet (106) allows percolation of water therethrough while preventing direct contact of the rock mineral wool layer (110) with the drainage sheet (105). Further, the
5 geotextile sheet prevents drainage of any loose fibers of the rock mineral wool layer (110).

In an embodiment, the geotextile sheet (106) is manufactured from non-woven continuous fibers of a material selected from polypropylene, polyethylene, polyester (PET), virgin polymer, recycled polymer, composites, or a combination thereof. In another embodiment, the thickness of the geotextile sheet (106) ranges between 0.3mm to 40mm. In yet another
10 embodiment, the weight of the geotextile sheet (106) ranges between 80GSM to 4000GSM. In a preferred embodiment, the weight of the geotextile sheet (106) ranges between 80GSM to 1000GSM.

In one embodiment, the rock mineral wool layer (110) is of a material selected from the group consisting of dolomite, basalt, granite, diabase, dolerite, or recycled slag. Due to its
15 hydrophilic nature, the rock mineral wool layer (110) can retain moisture therein for more than 10 hours, thus ensuring that the grass mat is always hydrated. In another embodiment, the thickness of the rock wool layer (110) ranges between 10mm to 100mm. In a preferred embodiment, the thickness of the rock wool layer (110) ranges between 20mm to 40mm.

In an embodiment, the rock mineral wool layer (110) is fastened on the drainage sheet (105)
20 with the help of fasteners (130). In another embodiment, the fasteners are fastened temporarily rock mineral wool layer (110)

In an embodiment, the vertical lawn (100) includes a plurality of brackets (127) configured to be fixed to the bottom layer of the rock mineral wool layer (110). The brackets (127) are fixed such that they protrude out through the rock mineral wool layer (110) and through the
25 lawn mat (115).

In another embodiment, the vertical lawn (100) includes a plurality of metal strip fitments (125) configured to be laid across the lawn mat (115). The strip fitments (125) are configured to be fastening received in the brackets (127) to securely hold the lawn mat (115) to the rock mineral wool layer (110), and prevent slippage of the lawn mat (115).

In yet another embodiment, the strip fitments (125) are laid across the lawn mat (115) in a crisscross manner, as shown in Figure 2A and Figure 2B. In still another embodiment, the strip fitments (125) are configured as a prefabricated meshed panel.

5 In an embodiment, as shown in Figure 4, the vertical lawn (100) includes a brace (142) having an L-shaped configuration defined by a base (143) and a first arm (144) extending from a first edge of the base (143). The brace (142) further includes an intermediate arm (145) extending from the first arm at a spaced apart distance from the base (143), in a direction parallel to the base (143).

10 In an embodiment, a plurality of perforations (146) is configured on the intermediate arm (145). In another embodiment, the intermediate arm (145) has a meshed configuration (not shown in Figures).

The base (143), of the brace (142), is configured to be attached to the substrate (140) and to an operative top portion of the drainage sheet (105) with the help of fasteners (not specifically shown in Figures). More specifically, the base (143) is inserted between the substrate (140) and the operative top portion of the drainage sheet (105). The brace (142) is configured to support the vertical lawn especially in high wind flow regions. Further, the drainage sheet (105) and the rock mineral wool layer (110) are received in the space defined between the base (143) and the intermediate arm (145). The perforations (146) or the meshed configuration of the intermediate arm (145) facilitates the roots of the lawn to grow into the rock mineral wool layer (110) therethrough, in addition to facilitating flow of water into the rock mineral wool layer (110).

25 In an embodiment, the lawn mat (115) includes a lawn substrate having a grass layer (117) grown thereon. In another embodiment, the grass layer (117) is selected from the group consisting of grass, sedum, succulents, hydroponics or herbs. In yet another embodiment, the thickness of the lawn mat (115) ranges between 30mm and 80mm.

In an operative configuration, after the rock mineral wool layer (110) is fitted on the drainage sheet (105), the rock mineral wool layer (110) is moistened. Thereafter, the lawn mat (115) is fitted on the rock mineral wool layer (110). The rock mineral wool layer (110) is periodically moistened to keep the lawn mat (115) moist by watering the lawn mat (115) and the rock mineral wool layer (110). Excess water percolates from the rock mineral wool layer (110) to the geotextile sheet (106). From the geotextile sheet (106), water passes on to the drainage

sheet (105), where water is flown away through the path created between the projections (107).

The drainage sheet (105) prevents the wall (140) from coming in contact with moisture. On the other hand, the rock mineral wool layer (110) provides support to the roots of the
5 vegetation of the lawn mat (115). Once the vegetation has rooted through the soil and the rock mineral wool layer (110), the strip fitments (125) are removed.

The vertical lawn (100) helps not only in increasing the aesthetic appeal of the building or space it is planted in, but also helps in reducing urban heat island effect. More specifically, the vertical lawn (100) will absorb a lot of heat and the absorbed heat energy used will be
10 used for evaporation and transpiration by the plants which will help not increasing the temperature of the atmosphere surrounding it and also of the concrete surface. Further, the lawn/plants/grass will absorb CO₂ and give out oxygen which will reduce the CO₂ emissions. Also the air particulate matter that settles on the leaves will be reduced thereby, reducing the air pollution in the atmosphere.

15 Moreover, the energy absorbed by the lawn (100) will not be transferred to the surface behind it, thus leading to a cooler indoor temperature that will increase the thermal efficiency of the building and reduce the energy requirement.

The foregoing description of the embodiments has been provided for purposes of illustration and not intended to limit the scope of the present disclosure. Individual components of a
20 particular embodiment are generally not limited to that particular embodiment, but, are interchangeable. Such variations are not to be regarded as a departure from the present disclosure, and all such modifications are considered to be within the scope of the present disclosure.

TECHNICAL ADVANCEMENTS

25 The present disclosure described hereinabove has several technical advantages including, but not limited to, the realization of a vertical lawn which:

- adds to the aesthetic appeal of spaces;
- allows draining of water therefrom, without affecting walls on which they are supported;

- reduces urban heat island effect;
- reduces air pollution and CO₂ content in the air; and
- increasing the thermal efficiency of the building.

The foregoing disclosure has been described with reference to the accompanying
5 embodiments which do not limit the scope and ambit of the disclosure. The description
provided is purely by way of example and illustration.

The embodiments herein and the various features and advantageous details thereof are
explained with reference to the non-limiting embodiments in the following description.
Descriptions of well-known components and processing techniques are omitted so as to not
10 unnecessarily obscure the embodiments herein. The examples used herein are intended
merely to facilitate an understanding of ways in which the embodiments herein may be
practiced and to further enable those of skill in the art to practice the embodiments herein.
Accordingly, the examples should not be construed as limiting the scope of the embodiments
herein.

15 The foregoing description of the specific embodiments so fully reveal the general nature of
the embodiments herein that others can, by applying current knowledge, readily modify
and/or adapt for various applications such specific embodiments without departing from the
generic concept, and, therefore, such adaptations and modifications should and are intended
to be comprehended within the meaning and range of equivalents of the disclosed
20 embodiments. It is to be understood that the phraseology or terminology employed herein is
for the purpose of description and not of limitation. Therefore, while the embodiments herein
have been described in terms of preferred embodiments, those skilled in the art will recognize
that the embodiments herein can be practiced with modification within the spirit and scope of
the embodiments as described herein.

25 Any discussion of materials, devices, articles or the like that has been included in this
specification is solely for the purpose of providing a context for the disclosure. It is not to be
taken as an admission that any or all of these matters form a part of the prior art base or were
common general knowledge in the field relevant to the disclosure as it existed anywhere
before the priority date of this application.

The numerical values mentioned for the various physical parameters, dimensions or quantities are only approximations and it is envisaged that the values higher/lower than the numerical values assigned to the parameters, dimensions or quantities fall within the scope of the disclosure, unless there is a statement in the specification specific to the contrary.

- 5 While considerable emphasis has been placed herein on the components and component parts of the preferred embodiments, it will be appreciated that many embodiments can be made and that many changes can be made in the preferred embodiments without departing from the principles of the disclosure. These and other changes in the preferred embodiment as well as other embodiments of the disclosure will be apparent to those skilled in the art from the disclosure herein, whereby it is to be distinctly understood that the foregoing descriptive matter is to be interpreted merely as illustrative of the disclosure and not as a limitation.
- 10

CLAIMS:

1. A vertical lawn (100) comprising:
 - an artificial substrate (140);
 - a water-proofing layer applied on said substrate (140);
- 5 • a drainage sheet (105) provided on said water-proofing layer, said drainage sheet (105) having a plurality of projections (107) configured thereon to facilitate flow of water between said projections (107);
- a geotextile sheet (106) fitted on an operative front surface of said drainage sheet (105);
- 10 • a hydrophilic rock mineral wool layer (110) secured to said operative front surface of said geotextile sheet (106), said rock mineral wool layer (110) configured to absorb and retain moisture therein;
- a lawn mat (115) secured to said rock mineral wool layer (110).
2. The vertical lawn (100) as claimed in claim 1, which is configured to incline at an angle
- 15 ranging between 45° to 120° with respect to the ground.
3. The vertical lawn (100) as claimed in claim 1, wherein said water-proofing layer is a layer of natural water-repellant material, or a layer of synthetic water-repellant material.
4. The vertical lawn (100) as claimed in claim 3, wherein said water-proofing layer is a water-repellent sheet.
- 20 5. The vertical lawn (100) as claimed in claim 3, wherein said water-proofing layer is a liquid water-repellent applied in coats.
6. The vertical lawn (100) as claimed in claim 3, wherein said water-proofing layer is selected from the group consisting of elastomeric material, cementitious material, latex, acrylic, polyurethane or a combination thereof.
- 25 7. The vertical lawn (100) as claimed in claim 1, wherein the thickness of said water-proofing layer ranges between 100 microns to 2000 microns.
8. The vertical lawn (100) as claimed in claim 1, wherein said projections (107) are configured on an operative front surface of said drainage sheet (105).

9. The vertical lawn (100) as claimed in claim 1, wherein said projections (107) are configured on both operative front surface and operative back surface of said drainage sheet (105).
10. The vertical lawn (100) as claimed in claim 1, wherein said projections (107) are configured on the drainage sheet (105) in a staggered configuration.
11. The vertical lawn (100) as claimed in claim 1, wherein each of said projections (107) has a configuration selected from the group consisting of cup-shaped configuration, trapezoidal configuration, and dimpled configuration.
12. The vertical lawn (100) as claimed in claim 1, wherein said projection (107) as a shape selected from the group consisting of circular, elliptical, ovular, rectangular, and octagonal.
13. The vertical lawn (100) as claimed in claim 1, wherein said the height of each projection (107) varies between 4mm to 25mm.
14. The vertical lawn (100) as claimed in claim 1, wherein said drainage sheet (105) is of a material selected from the group consisting of low density polyethylene (LDPE), high density polyethylene (HDPE), polypropylene, polyolefins, polyvinyl chloride, polyesters, polystyrene, recycled polymers, composites or a combination thereof.
15. The vertical lawn (100) as claimed in claim 1, wherein the thickness of said drainage sheet (105) ranges between 0.5mm to 1.5mm.
16. The vertical lawn (100) as claimed in claim 1, wherein said geotextile sheet (106) is manufactured from non-woven continuous fibers of a material selected from polypropylene, polyethylene, polyester (PET), virgin polymer, recycled polymer, composites, or a combination thereof.
17. The vertical lawn (100) as claimed in claim 1, wherein the thickness of said geotextile sheet (106) ranges between 0.3mm to 40mm.
18. The vertical lawn (100) as claimed in claim 1, wherein the weight of said geotextile sheet (106) ranges between 80GSM to 4000GSM.
19. The vertical lawn (100) as claimed in claim 1, wherein weight of said geotextile sheet (106) ranges between 80GSM to 1000GSM

20. The vertical lawn (100) as claimed in claim 1, wherein said rock mineral wool layer (110) is of a material selected from the group consisting of dolomite, basalt, granite, diabase, dolerite, or recycled slag.
21. The vertical lawn (100) as claimed in claim 1, wherein the thickness of said rock wool layer (110) ranges between 10mm to 100mm.
22. The vertical lawn (100) as claimed in claim 1, wherein the thickness of said rock wool layer (110) ranges between 20mm to 40mm.
23. The vertical lawn (100) as claimed in claim 1, wherein said rock mineral wool layer (110) is fastened on the drainage sheet (105) with the help of fasteners (130).
24. The vertical lawn (100) as claimed in claim 1, which includes a plurality of brackets (127) configured to be fixed to the bottom layer of the rock mineral wool layer (110) such that said brackets (127) protrude out through said rock mineral wool layer (110) and said lawn mat.
25. The vertical lawn (100) as claimed in claim 24, which includes metal strip fitments (125) configured to be laid across said lawn mat (115), said strip fitments (125) configured to be received in said brackets (127) to securely hold said lawn mat (115).
26. The vertical lawn (100) as claimed in claim 25, wherein said strip fitments (125) are laid across the lawn mat (115) in a crisscross manner.
27. The vertical lawn (100) as claimed in claim 25, wherein said strip fitments (125) are configured as a prefabricated meshed panel.
28. The vertical lawn (100) as claimed in claim 1, which includes a brace (142) having an L-shaped configuration defined by a base (143), a first arm (144) extending from a first edge of the base (143), and an intermediate arm (145) extending from the first arm at a spaced apart distance from the base (143), in a direction parallel to the base (143), said brace (142) being configured to be attached to said substrate (140) and to an operative top portion of said drainage sheet (105) to provide additional support to said vertical lawn (100).
29. The vertical lawn (100) as claimed in claim 28, wherein a plurality of perforations (146) is configured on the intermediate arm (145) to facilitate flow of water therethrough.

30. The vertical lawn (100) as claimed in claim 28, wherein said intermediate arm (145) has a meshed configuration to facilitate flow of water therethrough.
31. The vertical lawn (100) as claimed in claim 1, wherein said lawn mat (115) includes a lawn substrate having a grass layer (117) grown thereon.
- 5 32. The vertical lawn (100) as claimed in claim 31, wherein said grass layer (117) is selected from the group consisting of grass, sedum, succulents, hydroponics or herbs.
33. The vertical lawn (100) as claimed in claim 31, wherein the thickness of said lawn mat (115) ranges between 30mm and 80mm.

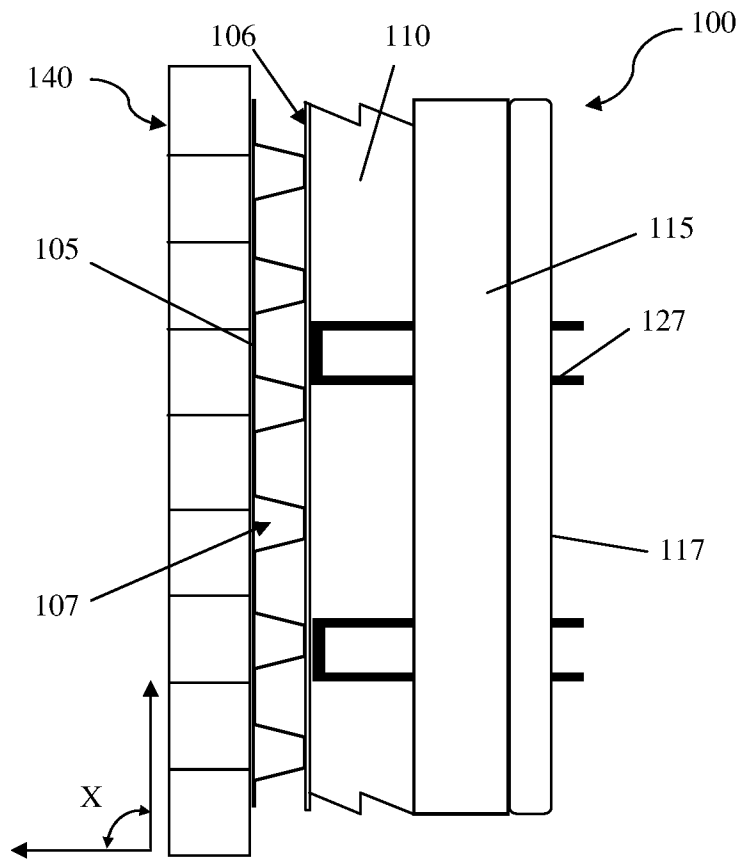

Figure 1A

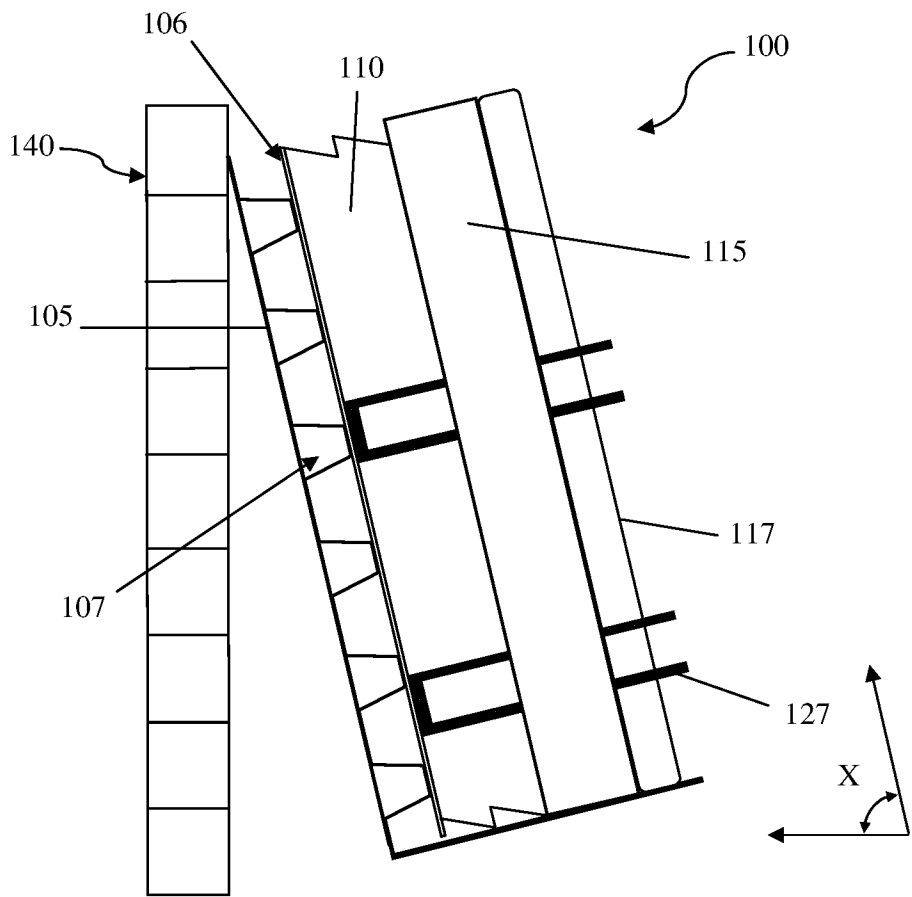

Figure 1B

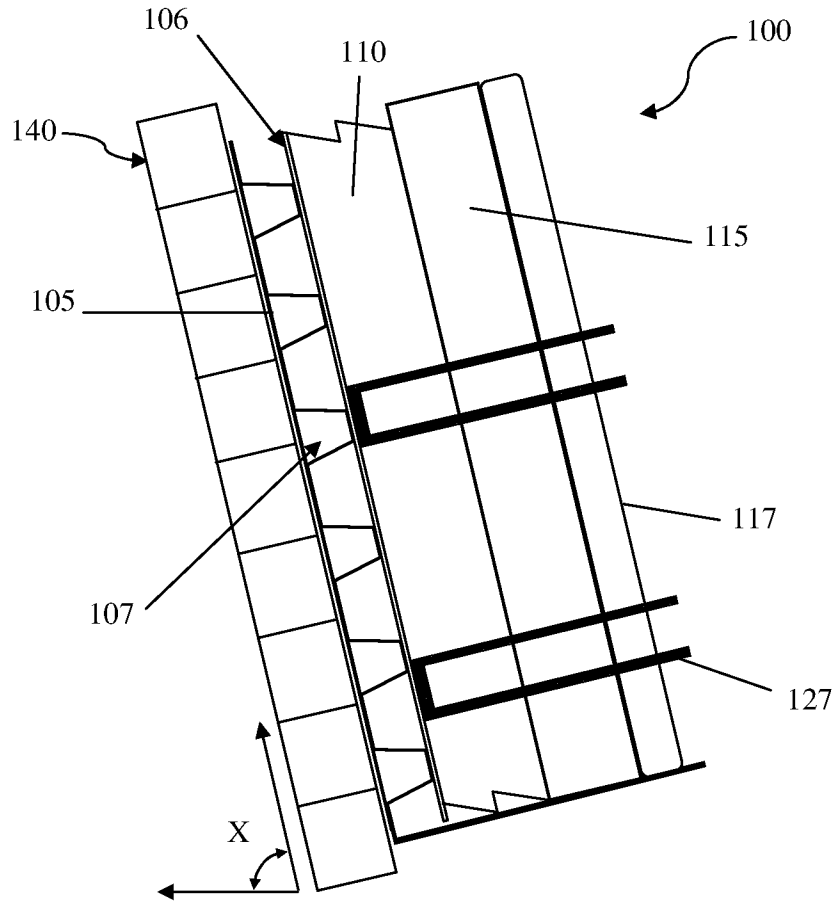

Figure 1C

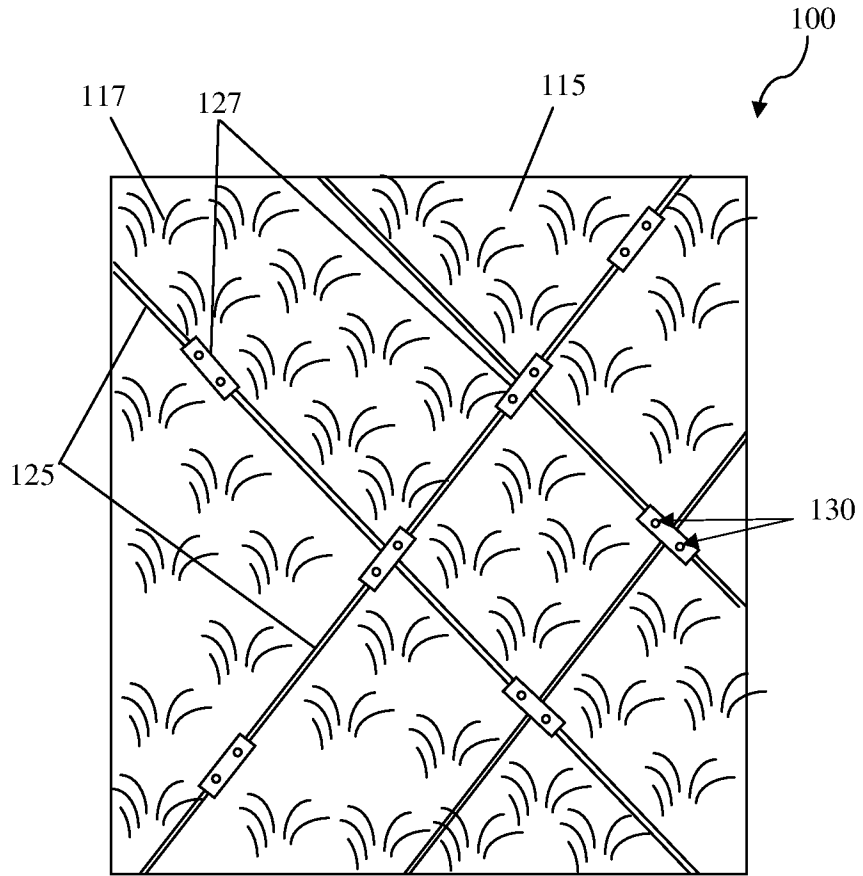

Figure 2A

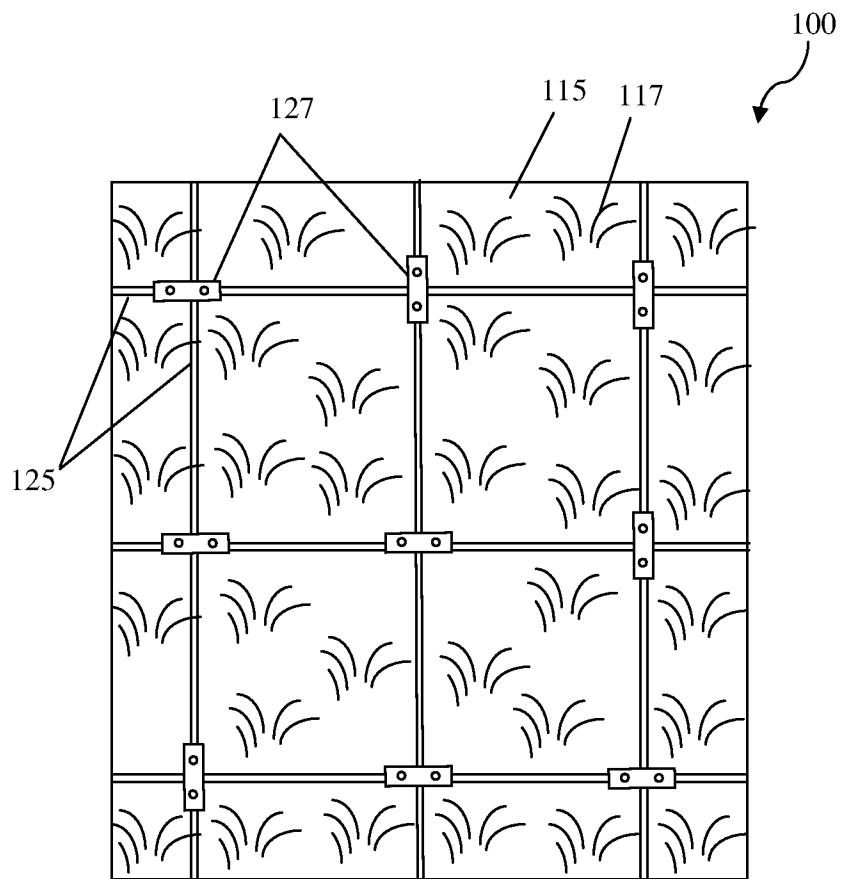

Figure 2B

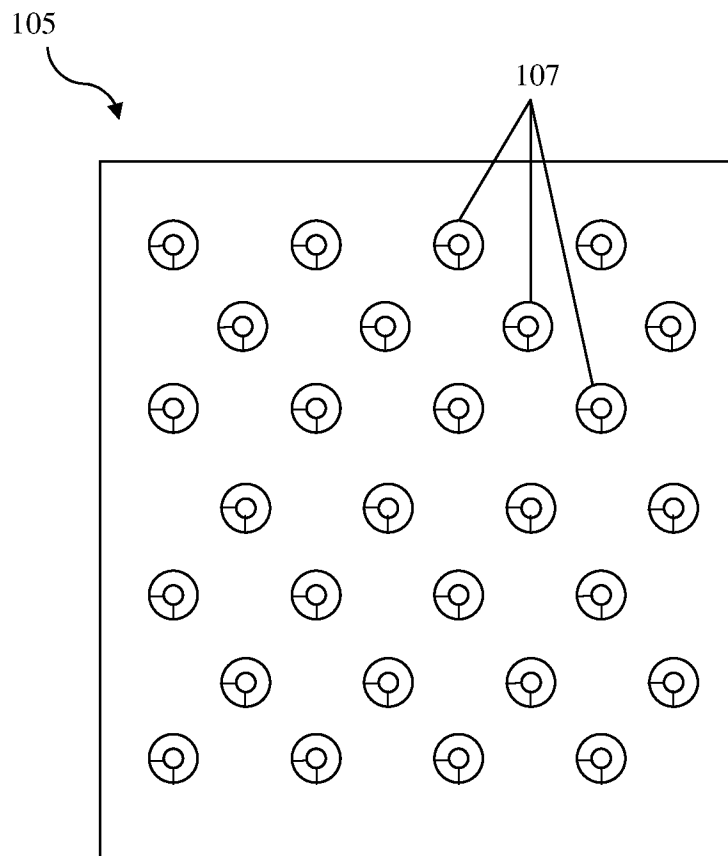

Figure 3

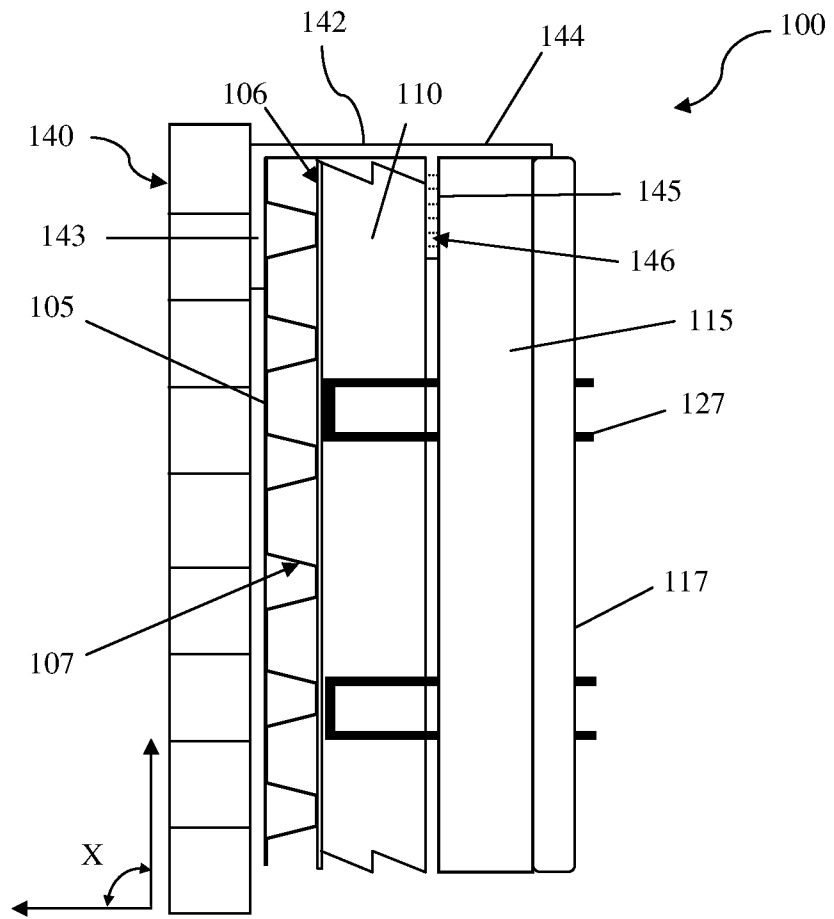

Figure 4

INTERNATIONAL SEARCH REPORT

International application No.

PCT/IB2022/059711

A. CLASSIFICATION OF SUBJECT MATTER A01G9/02 Version=2023.01		
According to International Patent Classification (IPC) or to both national classification and IPC		
B. FIELDS SEARCHED		
Minimum documentation searched (classification system followed by classification symbols) A01G*, C05G* & D04H*		
Documentation searched other than minimum documentation to the extent that such documents are included in the fields searched		
Electronic database consulted during the international search (name of database and, where practicable, search terms used) PatSeer, IPO Internal Database		
C. DOCUMENTS CONSIDERED TO BE RELEVANT		
Category*	Citation of document, with indication, where appropriate, of the relevant passages	Relevant to claim No.
Y	EP2983463B1 (SHAH KUMARPAL [IN]) 10 May 2017 (10.05.2017) Col 7, Para 0044 & Col 6, Para 0038, Figs 2-9	1-33
Y	CN101553108B (PHILIPPE HUET) 03 Aug 2011 (03.08.2011) Para 0010, 0015, 0035-0037, Fig 1 & Abstract [English translation on espacenet]	1-33
Y	GB2531796A (CHA TECH GROUP PLC [GB]) 04 May 2016 (04.05.2016) Page 10, Lines 20-25, Page 3, Lines 13-16, Page 6, Lines 20-24 & Fig 1	1-33
Y	US5600919A (SAINT GOBAIN ISOVER [FR]) 11 Feb 1997 (11.02.1997) Col 2, Lines 27-36, Col 4, Lines 50-53	1-33
<input type="checkbox"/> Further documents are listed in the continuation of Box C.		<input checked="" type="checkbox"/> See patent family annex.
* Special categories of cited documents:	"T" later document published after the international filing date or priority date and not in conflict with the application but cited to understand the principle or theory underlying the invention	
"A" document defining the general state of the art which is not considered to be of particular relevance	"X" document of particular relevance; the claimed invention cannot be considered novel or cannot be considered to involve an inventive step when the document is taken alone	
"D" document cited by the applicant in the international application	"Y" document of particular relevance; the claimed invention cannot be considered to involve an inventive step when the document is combined with one or more other such documents, such combination being obvious to a person skilled in the art	
"E" earlier application or patent but published on or after the international filing date	"&" document member of the same patent family	
"L" document which may throw doubts on priority claim(s) or which is cited to establish the publication date of another citation or other special reason (as specified)		
"O" document referring to an oral disclosure, use, exhibition or other means		
"P" document published prior to the international filing date but later than the priority date claimed		
Date of the actual completion of the international search 23-01-2023	Date of mailing of the international search report 23-01-2023	
Name and mailing address of the ISA/ Indian Patent Office Plot No.32, Sector 14,Dwarka,New Delhi-110075 Facsimile No.	Authorized officer Haribansh Kumar Telephone No. +91-1125300200	

INTERNATIONAL SEARCH REPORT
Information on patent family members

International application No.

PCT/IB2022/059711

Citation	Pub.Date	Family	Pub.Date		
EP 2983463 B1	10-05-2017	IN 1357/MUM/2013 A	10-04-2015		
		AU 2014252177 A1	25-01-2018		
		US 20160050856 A1	25-02-2016		
		JP 2016518120 A	23-06-2016		
		EA 201591554 A1	29-04-2016		
		CN 105101784 A	25-11-2015		
		WO 2014167576 A1	16-10-2014		
		SA 515361277 B1	17-07-2016		
		CN 101553108 B	03-08-2011	FR 2906822 B1	06-02-2009
				WO 2008043904 A1	17-04-2008
EP 2076112 A1	08-07-2009				
US 20100095584 A1	22-04-2010				
US 5600919 A	11-02-1997	DE 4035249 A1	07-05-1992		
		AU 646697 B2	03-03-1994		
		ZA 918737 B	26-08-1992		
		KR 920009283 A	25-06-1992		
		AT 120073 T	15-04-1995		
		DK 0485277 T3	06-06-1995		
		EP 0485277 B1	22-03-1995		
		JP 06121626 A	06-05-1994		
		CA 2054943 A1	07-05-1992		
		ES 2069856 T3	16-05-1995		
		DE 69108351 T2	20-07-1995		