



US00D898677S

(12) **United States Design Patent**
Zhang et al.

(10) **Patent No.:** **US D898,677 S**
(45) **Date of Patent:** **** Oct. 13, 2020**

(54) **TERMINAL WITH A RECTANGULAR EDGE PROTRUSION**

D555,597 S 11/2007 Phung et al.
D741,554 S * 10/2015 Moreau D29/122
9,559,475 B1 1/2017 Shaeffer et al.
D778,508 S * 2/2017 Moreau D29/122
9,966,713 B1 5/2018 Shaeffer et al.
(Continued)

(71) Applicant: **Eaton Intelligent Power Limited,**
Dublin (IE)

(72) Inventors: **George Zhang,** Shanghai (CN); **Alex Zhuang,** Shanghai (CN); **Dai Vo,** McDonough, GA (US)

(73) Assignee: **Eaton Intelligent Power Limited,**
Dublin (IE)

(**) Term: **15 Years**

(21) Appl. No.: **29/680,061**

(22) Filed: **Feb. 13, 2019**

Related U.S. Application Data

(62) Division of application No. 29/572,225, filed on Jul. 26, 2016, now Pat. No. Des. 845,246.

(51) **LOC (12) Cl.** **13-03**

(52) **U.S. Cl.**
USPC **D13/154**

(58) **Field of Classification Search**
USPC D13/103, 107, 108, 110, 112, 118, 120, D13/123, 133, 137.1, 145-147, 149-156, D13/158, 173, 177, 184, 199, 242; D14/240, 242, 433, 434, 435.1, 438; D29/122
CPC H01R 13/05; H01R 13/44; H01R 13/52; H01R 13/66; H01R 24/66; H01R 24/86; H01R 27/00; H01R 33/00; H01R 43/26
See application file for complete search history.

(56) **References Cited**

U.S. PATENT DOCUMENTS

4,936,795 A * 6/1990 Kawai H01R 13/655
439/607.19
6,447,302 B1 9/2002 Davis

OTHER PUBLICATIONS

The Home Depot. Electrical PLugs & Connectors. No date specified. <https://www.homedepot.com/b/Electrical-Wiring-Devices-Light-Controls-Electrical-Plugs-Connectors/N-5yc1vZc336> (Year: 0).*
(Continued)

Primary Examiner — Darcey E Gottschalk
(74) *Attorney, Agent, or Firm* — Myers Bigel, P.A.

(57) **CLAIM**

The ornamental design for a terminal with a rectangular edge protrusion, as shown and described.

DESCRIPTION

FIG. 1 is a rear, side perspective view of a terminal with a rectangular edge protrusion;
FIG. 2 is a front, side perspective view of the terminal with a rectangular edge protrusion;
FIG. 3 is a front view thereof;
FIG. 4 is a rear view thereof;
FIG. 5 is another rear, side perspective view thereof;
FIG. 6 is another front, side perspective view thereof;
FIG. 7 is a top view thereof;
FIG. 8 is a bottom view thereof;
FIG. 9 is a side environmental view thereof illustrating the terminal in a connector housing; and,
FIG. 10 is a side environmental view thereof with a laterally inward facing screw in position in a connector housing.
In the drawings, the broken lines depict environment that form no part of the claim.

1 Claim, 9 Drawing Sheets

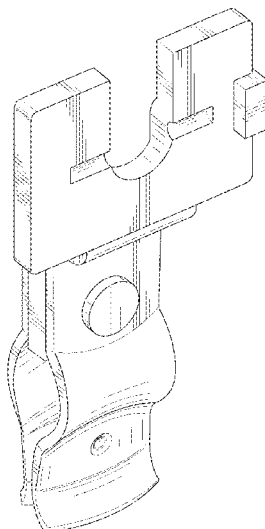

(56)

References Cited

U.S. PATENT DOCUMENTS

D823,814	S *	7/2018	Buck	D13/154
D834,475	S *	11/2018	Rode	D12/180
10,297,956	B2 *	5/2019	Abouklassesem	H01R 24/64
10,418,756	B2 *	9/2019	Fennen	H01R 13/506
10,476,199	B2 *	11/2019	Kim	H01R 13/5213
10,541,501	B2 *	1/2020	Hutchison	H01R 27/00
D877,088	S *	3/2020	Musser	D13/154
D880,074	S *	3/2020	Proctor	D29/122
2011/0228563	A1	9/2011	Dhenaut et al.		
2013/0137310	A1 *	5/2013	Genau	H01R 13/6471 439/660
2014/0017910	A1	1/2014	Gerling		
2017/0077634	A1	3/2017	Markefka		

OTHER PUBLICATIONS

Technical Data, Industrial grade straight blade quick grip devices,
www.arrowhart.com (3 pages) (Jan. 2014).

* cited by examiner

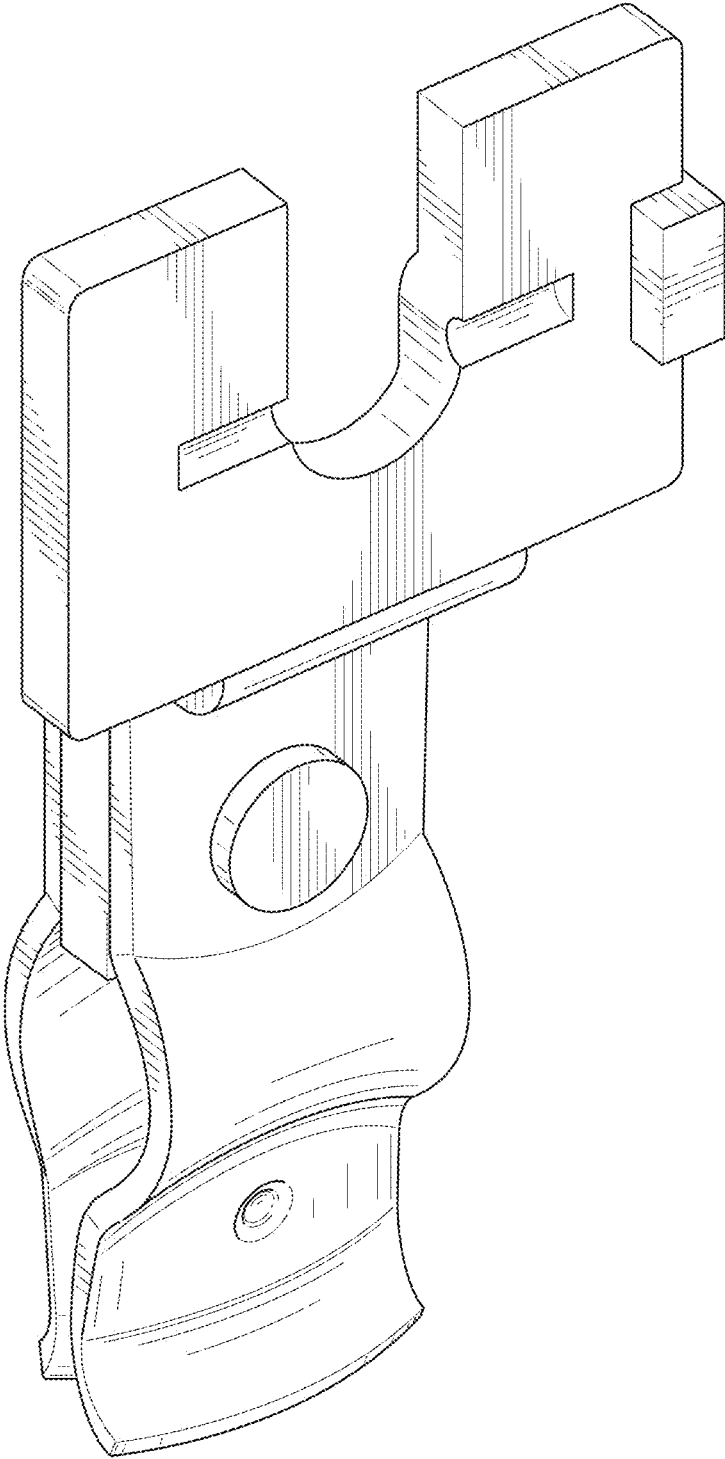

FIG. 1

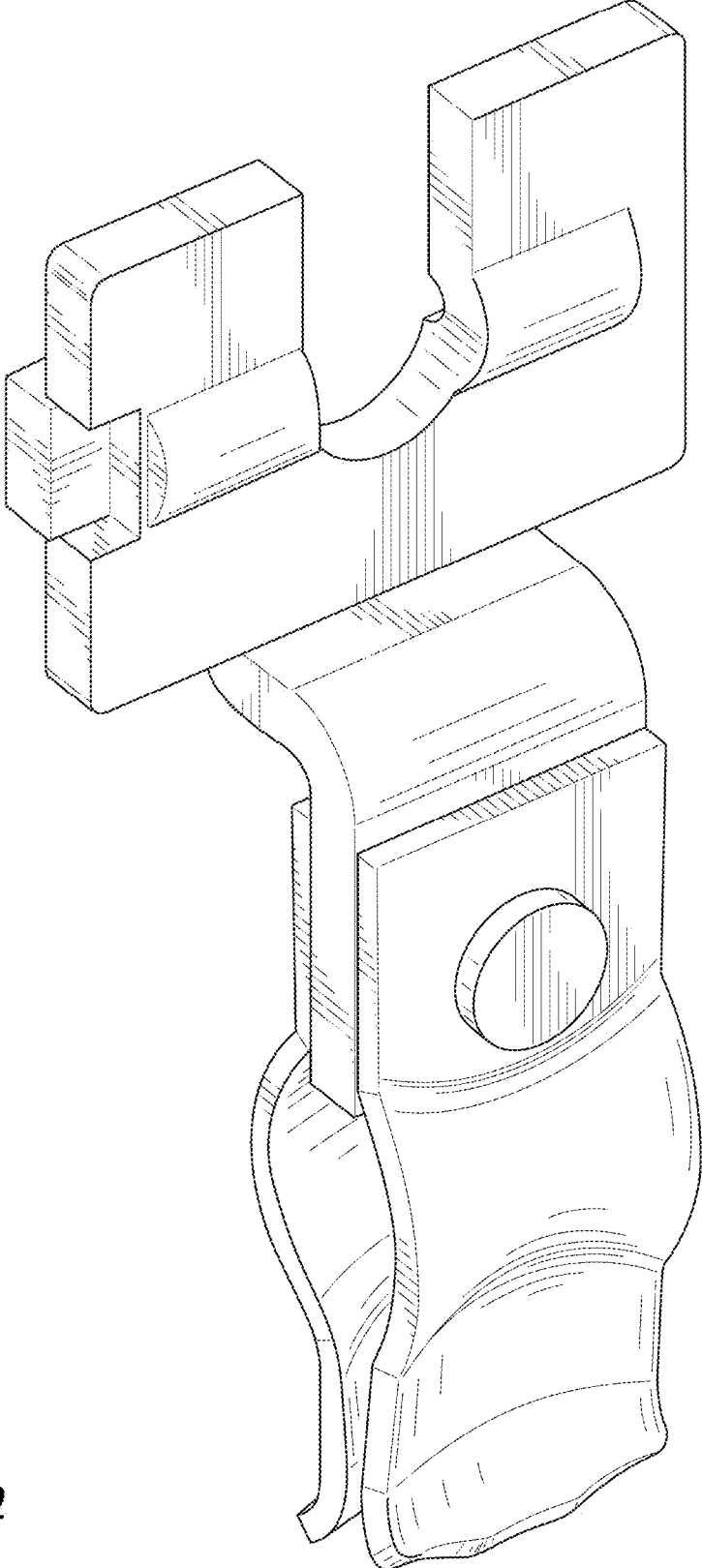

FIG. 2

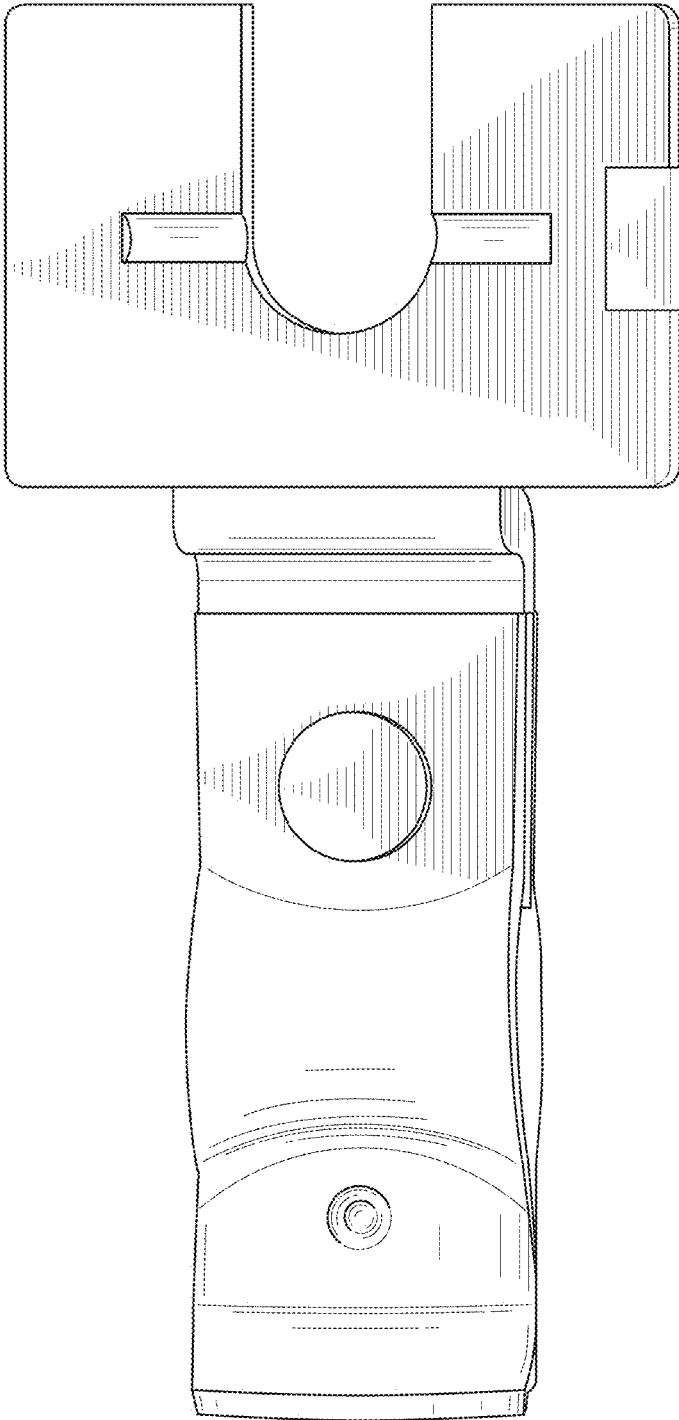

FIG. 3

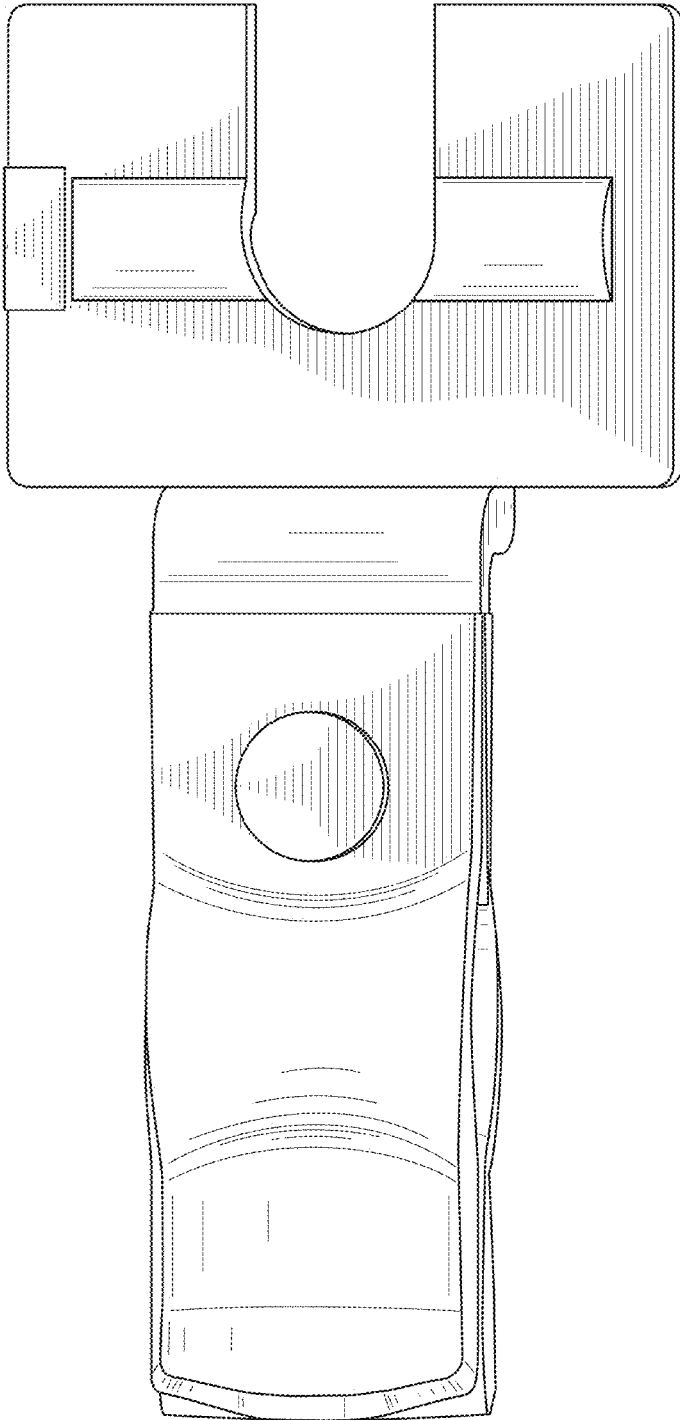

FIG. 4

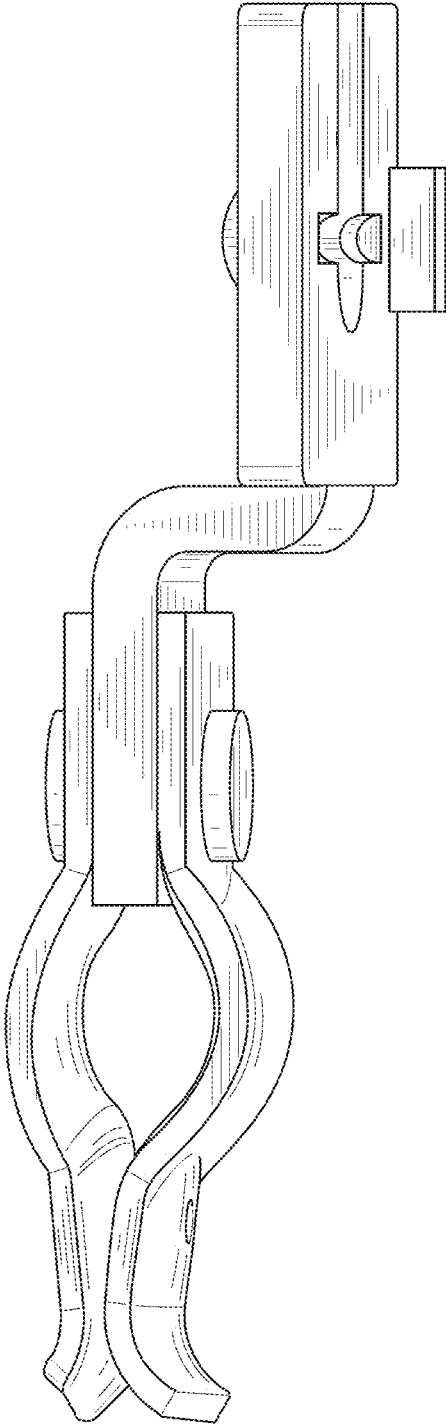

FIG. 5

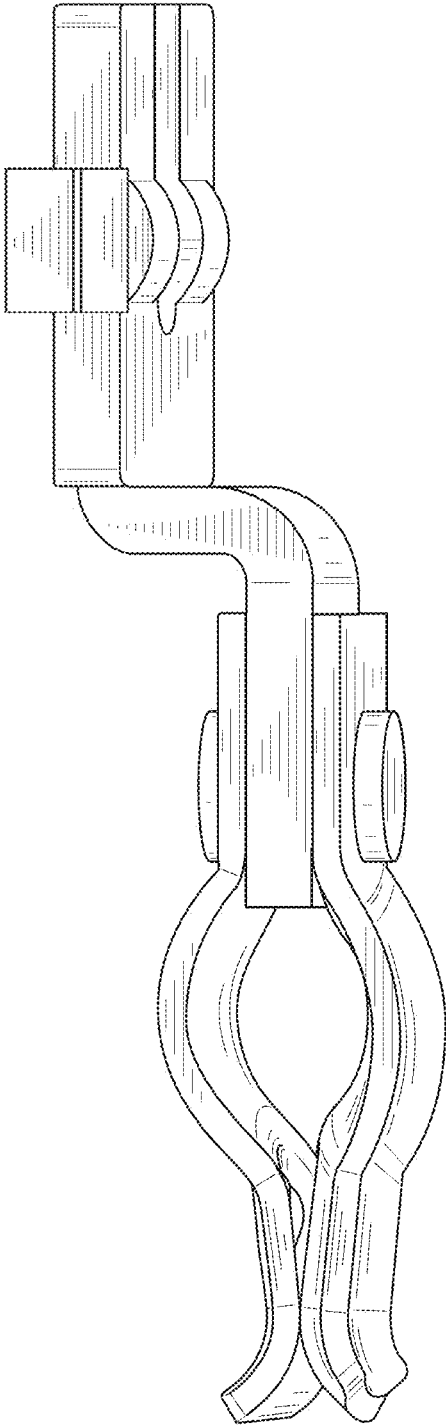

FIG. 6

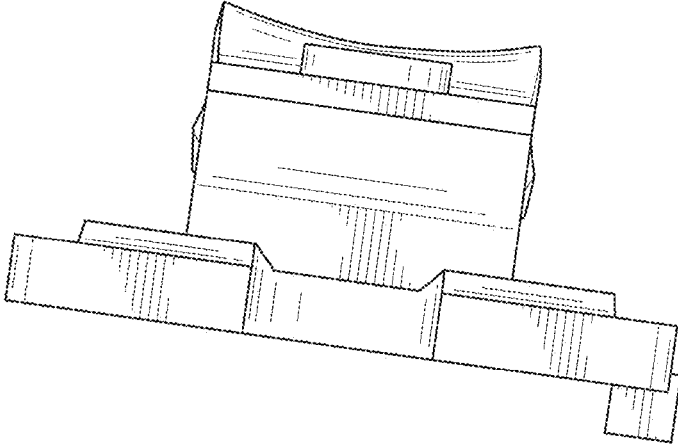

FIG. 7

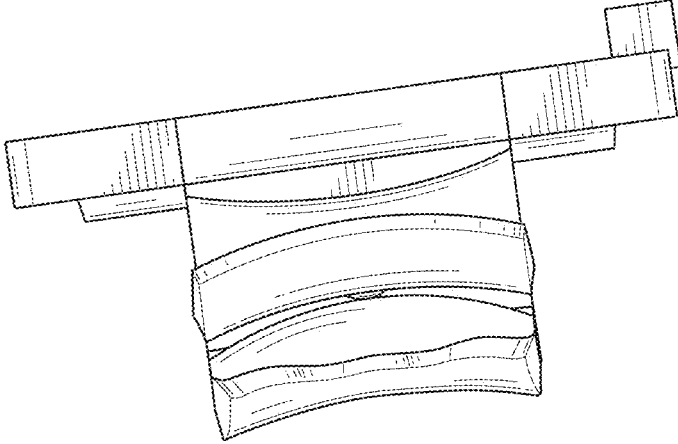

FIG. 8

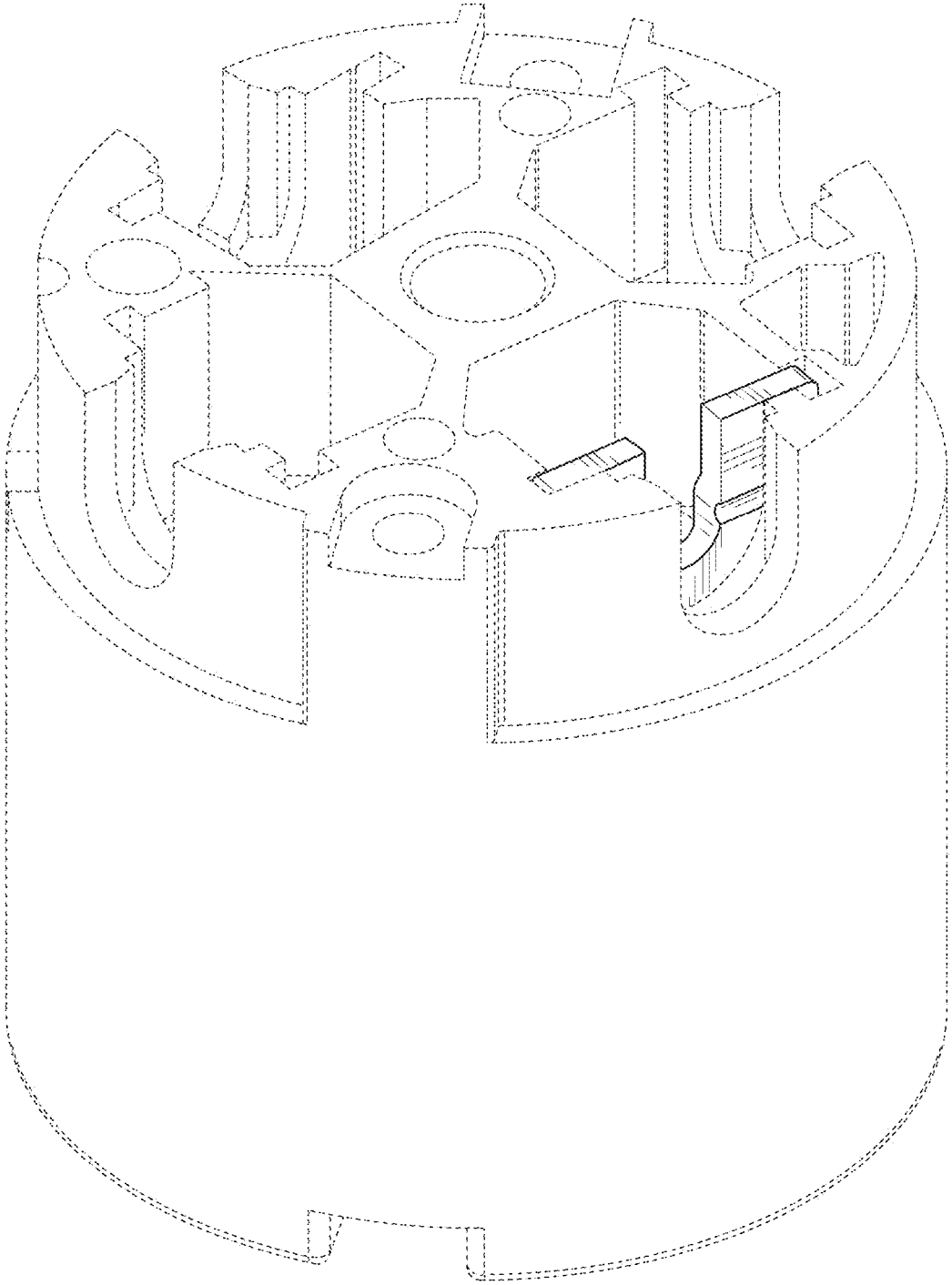

FIG. 9

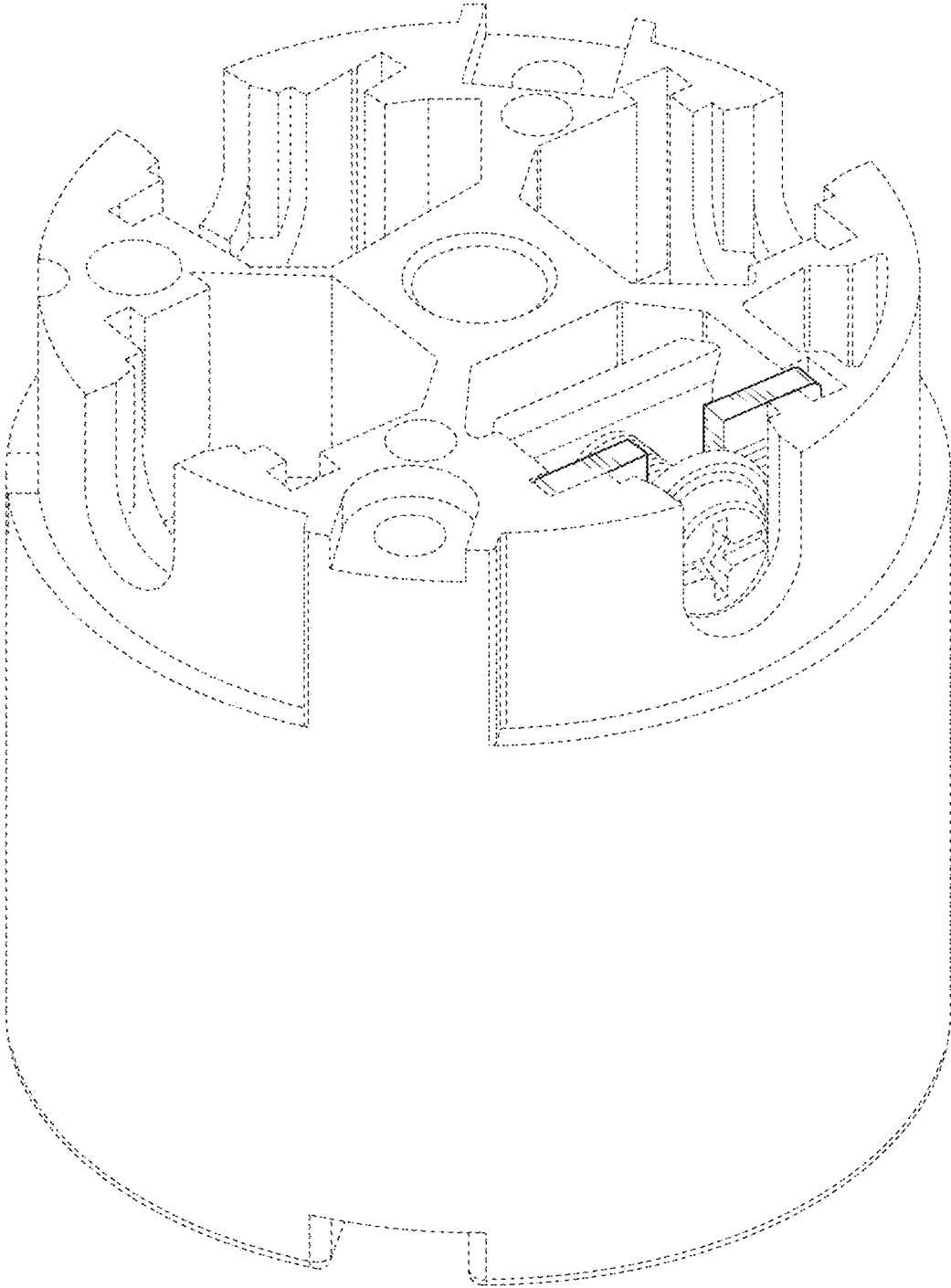

FIG. 10