

⑫ **EUROPEAN PATENT APPLICATION**

⑰ Application number: **84200641.3**

⑤① Int. Cl.⁴: **B 63 H 9/10, B 65 H 57/12,**
B 65 H 59/12

⑱ Date of filing: **07.05.84**

⑳ Priority: **10.05.83 NL 8301670**

⑦① Applicant: **Jonkers, Peter Andreas, Spinveld 35,**
NL-4815 HR Breda (NL)

④③ Date of publication of application: **06.03.85**
Bulletin 85/10

⑧④ Designated Contracting States: **BE DE FR GB IT NL SE**

⑧⑧ Date of deferred publication of search
report: **24.04.85 Bulletin 85/17**

⑦② Inventor: **Jonkers, Peter Andreas, Spinveld 35,**
NL-4815 HR Breda (NL)

⑤④ **Boom-brake; slowing down apparatus for a boom or such and the procedure for the manufacture of the apparatus.**

⑤⑦ The apparatus distinguishes itself by a closed casing (2) that is relatively small and light, with two oval openings (8), between which a channel (9) – included in the casing (2) – extends in order to take in a flexible element such as a rope, which is attached to the ship between two points that are at some distance from each other.

The apparatus has been applied in such a way that at a swing of a boom or tiller the flexible element is being pulled through the channel, the latter exhibiting a slowing-down effect on the flexible element as a result of the friction.

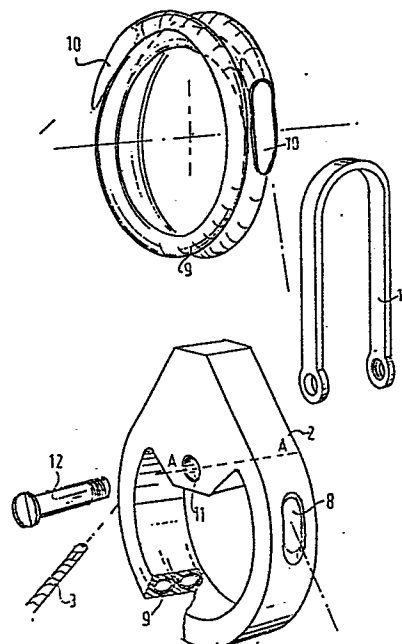



DOCUMENTS CONSIDERED TO BE RELEVANT			
Category	Citation of document with indication, where appropriate, of relevant passages	Relevant to claim	CLASSIFICATION OF THE APPLICATION (Int. Cl.4)
P, X	FR-A-2 521 096 (ANGAR) * whole document *	1, 2, 9, 10	B 63 H 9/10 B 65 H 57/12 B 65 H 59/12
Y	DE-A-3 202 703 (BANDINI) * whole document *	1	
Y	US-A-3 514 048 (LOWERY) * column 1, lines 12-14; figures 1-3 *	1	
A, D	US-A-3 750 612 (D'AGOSTINO)		
A, D	FR-A-2 449 031 (CHUBILLEAU)		
A, D	FR-A-2 364 813 (WAELDER)		
The present search report has been drawn up for all claims			TECHNICAL FIELDS SEARCHED (Int. Cl.4) B 63 B B 63 H B 65 H
Place of search THE HAGUE		Date of completion of the search 02-11-1984	Examiner DE SCHEPPER H.P.H.
<p>CATEGORY OF CITED DOCUMENTS</p> <p>X : particularly relevant if taken alone Y : particularly relevant if combined with another document of the same category A : technological background O : non-written disclosure P : intermediate document</p> <p>T : theory or principle underlying the invention E : earlier patent document, but published on, or after the filing date D : document cited in the application L : document cited for other reasons</p> <p>& : member of the same patent family, corresponding document</p>			

