

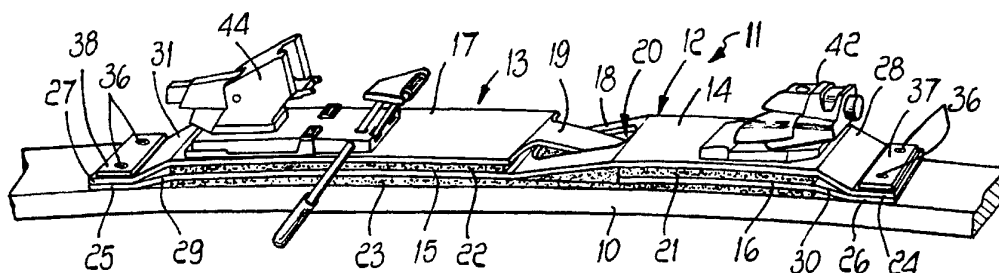

INTERNATIONAL APPLICATION PUBLISHED UNDER THE PATENT COOPERATION TREATY (PCT)

(51) International Patent Classification ⁶ : A63C 5/07	A1	(11) International Publication Number: WO 95/07737 (43) International Publication Date: 23 March 1995 (23.03.95)
<p>(21) International Application Number: PCT/EP94/03015</p> <p>(22) International Filing Date: 8 September 1994 (08.09.94)</p> <p>(30) Priority Data: PD93A000180 13 September 1993 (13.09.93) IT PD93A000227 17 November 1993 (17.11.93) IT</p> <p>(71)(72) Applicant and Inventor: MAGGIOLO, Marco [IT/IT]; Via Roncegno, 1, I-30030 Chirignago (IT).</p> <p>(74) Agent: MODIANO, Guido; Modiano & Associati, Via Meravigli, 16, I-20123 Milan (IT).</p>	<p>(81) Designated States: CA, JP, NO, SI, US, European patent (AT, BE, CH, DE, DK, ES, FR, GB, GR, IE, IT, LU, MC, NL, PT, SE).</p> <p>Published <i>With international search report.</i></p>	

(54) Title: DEVICE FOR IMPROVING THE EFFICIENCY AND CONTROLLABILITY OF SKIS



(57) Abstract

The device for improving the efficiency and controllability of skis has two elongated shaped plate-like elements (12, 13), each having one end (24, 27) provided with locking members (36, 38, 39b) for fixing to the ski and another end (25, 26) provided with retention members (39a) which allow the other end (25, 26) to slide longitudinally with respect to the ski (10). A toe unit (42) or heel unit (44) of a ski binding is fixed proximate to one of the ends.

FOR THE PURPOSES OF INFORMATION ONLY

Codes used to identify States party to the PCT on the front pages of pamphlets publishing international applications under the PCT.

AT	Austria	GB	United Kingdom	MR	Mauritania
AU	Australia	GE	Georgia	MW	Malawi
BB	Barbados	GN	Guinea	NE	Niger
BE	Belgium	GR	Greece	NL	Netherlands
BF	Burkina Faso	HU	Hungary	NO	Norway
BG	Bulgaria	IE	Ireland	NZ	New Zealand
BJ	Benin	IT	Italy	PL	Poland
BR	Brazil	JP	Japan	PT	Portugal
BY	Belarus	KE	Kenya	RO	Romania
CA	Canada	KG	Kyrgystan	RU	Russian Federation
CF	Central African Republic	KP	Democratic People's Republic of Korea	SD	Sudan
CG	Congo	KR	Republic of Korea	SE	Sweden
CH	Switzerland	KZ	Kazakhstan	SI	Slovenia
CI	Côte d'Ivoire	LI	Liechtenstein	SK	Slovakia
CM	Cameroon	LK	Sri Lanka	SN	Senegal
CN	China	LU	Luxembourg	TD	Chad
CS	Czechoslovakia	LV	Latvia	TG	Togo
CZ	Czech Republic	MC	Monaco	TJ	Tajikistan
DE	Germany	MD	Republic of Moldova	TT	Trinidad and Tobago
DK	Denmark	MG	Madagascar	UA	Ukraine
ES	Spain	ML	Mali	US	United States of America
FI	Finland	MN	Mongolia	UZ	Uzbekistan
FR	France			VN	Viet Nam
GA	Gabon				

DEVICE FOR IMPROVING THE EFFICIENCY AND CONTROLLABILITY OF
SKIS

Technical Field

The present invention relates to a device for improving the efficiency and controllability of skis.

Background Art

As is known, one of the characteristics of the shape of skis is that the surface of the ski is curved, with a central region that is raised with respect to the ends so as to form an upward convexity.

During use, skis are subjected to stresses that tend to flatten the convexity due to the elasticity of the materials of which the skis are made.

This occurs particularly when negotiating curves and has negative consequences on ski efficiency and control.

In particular, the continuous change of the convexity of the skis alters the distance between the elements that form the ski bindings, the toe unit and the heel unit, considering that the boot is located at the center of gravity.

In Alpine competition skiing, the stresses to which the skis are subjected are very high and cause difficulties in control, unexpected losses of balance, the need for continuous attitude corrections, and the transmission of vibrations to the athlete's legs.

In order to reduce the above drawbacks, devices commonly termed pads have been devised and are currently in use; said devices are interposed between the skis and the bindings.

However, so far none of the available devices allows

satisfactory direct control of the skis.

Among these devices, a first one comprises a metal lamina having a rear end stably fixed to the ski and a front end retained so that it slides parallel to said ski; 5 a layer of elastic material is applied between the metal lamina and the ski, and the middle portion of the lamina, on which the bindings are fixed, is raised.

With this device, the distance between the toe unit and the heel unit of the binding is kept constant, but its 10 position with respect to the center of gravity of the ski becomes variable.

For example, during extension the toe unit, and thus the boot, shift forward with a consequent change in positional relationship between the skier and the ski (the 15 center of gravity is shifted).

Another drawback in the use of this device is due to the fact that the mobility of its front part worsens steerability and controllability of the ski, which is mainly maneuvered with its front part, with consequent 20 inaccuracy in setting trajectories, the need for continuous corrections, and a consequent limitation of speed.

In a second type of device, similar to the preceding one, the toe unit of the binding is fixed to two supports that are rigidly coupled to the ski, and the heel unit is 25 applied to a metal lamina that is longitudinally slideable.

This improves the setup of the curve trajectory, but the fact that the heel unit is movable with respect to the ski and with respect to the toe unit causes an inconstant positional relationship between the boot and the binding 30 and therefore between the boot and the ski, making ski

control inaccurate.

A third type of device has a metal lamina which is shaped so as to have two raised regions at the regions where the heel unit and the toe unit are fixed.

5 The lamina is fixed to the ski both at the front and at the rear, and a layer of elastic material is placed in the regions where said lamina is raised.

This device has the only positive effect of damping vibrations that are transmitted from the ski to the
10 athlete's leg.

Disclosure of the Invention

The aim of the present invention is to provide a new device for improving the efficiency and controllability of skis which eliminates or substantially reduces the drawbacks described above in known types.

15 A consequent primary object is to provide a device that improves the efficiency and controllability of skis, keeping the position of the boot unchanged with respect to the ski and maintaining a center-of-gravity position for the skier.

20 Another important object is to provide a device that allows to control and adjust the longitudinal movement of the ski.

Another important object is to provide a device that allows to achieve faster skiing.

25 Another object is to provide a device that can also be configured so that it can absorb the stresses induced in a substantially vertical direction on the ski.

Another object is to improve ski control in any situation, especially when negotiating curves.

Another object is to provide a device that can be manufactured with conventional equipment and facilities.

This aim, these objects and others which will become apparent hereinafter are achieved by a device for improving
5 the efficiency and controllability of skis, characterized in that it comprises at least two elongated shaped plate-like elements, each element having a first end provided with means for fixing to the ski and a second end provided with retention means which allow said second end to slide
10 longitudinally with respect to said ski, a toe unit or heel unit of a ski binding being fixed on one of said ends or adjacent thereto.

Brief description of the drawings

Further characteristics and advantages of the invention will become apparent from the following detailed
15 description of an embodiment thereof, illustrated only by way of non-limitative example in the accompanying drawings, wherein:

figure 1 is a perspective view of the device applied to a ski;

20 figure 2 is a longitudinally sectional perspective view of the device;

figure 3 is an exploded view of the device;

figure 4 is a top plan view of the device;

25 figures 5 and 6 are longitudinal sectional views of each end of the device;

figure 7 is a perspective view of an element included in the device.

Ways of carrying out the invention

With reference to the above figures, a device

according to the invention, conveniently applied at the upper center-of-gravity region of a ski 10, is generally designated by the reference numeral 11 and comprises two elongated shaped metal laminae, respectively a first lamina 12 and a second lamina 13, which are appropriately made of aluminum alloy or equivalent materials.

The first lamina 12 and the second lamina 13 extend upwardly from their ends, on inclined planes, so that they are raised with respect to the surface for resting on the ski 10; each lamina has two portions, respectively a first lamina front portion 14, a first lamina rear portion 15, a second lamina front portion 16 and a second lamina rear portion 17, that lie at mutually different levels.

The first lamina rear portion 15 is located at a different level with respect to the first lamina front portion 14, and is connected thereto by a first lamina inclined region 18. Similarly, the second lamina rear portion 17 is located at a different level with respect to the second lamina front portion 16, and is connected thereto by a second lamina inclined region 19.

At the first lamina inclined region 18, the first lamina 12 has a wide longitudinal slotted hole 20 which is traversed by the second lamina inclined region 19, which is appropriately tapered with respect to the rest of said second lamina 13.

In this manner, the two laminae 12 and 13 mutually intersect at the inclined regions 18,19 and the various flat portions 14, 15, 16, 17 overlap.

In particular, with reference to the figures, the first lamina front portion 14 overlaps the second lamina

front portion 16 and the second lamina rear portion 17 overlaps the first lamina rear portion 15.

The first lamina front portion 14 and the second lamina rear portion 17 lie substantially at the same level, and the same is true for the first lamina rear portion 15 and the second lamina front portion 16.

Layers, respectively a front upper layer 21, a rear upper layer 22, and a lower layer 23, made of elastic material, or equivalent devices, can be conveniently interposed between the various overlapping portions 14, 15, 16, 17 and between said portions 14, 15, 16, 17 and the ski 10. In the illustrated example, the front upper layer 21 is interposed between the first lamina front portion 14 and the second lamina front portion 16; the rear upper layer 22 is interposed between the first lamina rear portion 15 and the second lamina rear portion 17; the lower layer 23 is interposed between the upper surface of the ski 10, and the lower surfaces of the first lamina rear portion 15 and the second lamina front portion 16.

The front end 24 and the rear end 25 of the first lamina 12, and the front end 26 and the rear end 27 of the second lamina 13, are also flat, mutually overlap, and are joined to the ski by means of inclined portions, designated by the reference numerals 28 and 29 for the first lamina 12 and by the reference numerals 30 and 31 for the second lamina 13.

Said ends 24, 25, 26, 27 each have longitudinal slotted holes, respectively 32, 33 for the first lamina 12 and 34, 35 for the second lamina 13, for fixing to the ski 10 by means of screws 36.

Plates 37 and 38 are arranged on the overlapping ends 24, 26 and 25, 27 respectively.

The screws 36 pass through the plates 37 and 38 and through shaped elements 39; each shaped element 39 has a portion 39a, which is shaped complementarily with respect to the profile of the slotted holes 32, 33, 34, and 35, and a parallelepipedal portion or narrowed portion 39b, which is arranged centrally with respect to the complementarily-shaped portion 39a.

10 The two portions 39a and 39b have substantially the same thickness as the laminae 12 and 13.

When the corresponding screw 36 is fixed, the shaped element 39 blocks one lamina with its portion 39a, whereas its portion 39b leaves the other lamina free to shift.

15 Each element 39 can be arranged so that its portion 39a is at the top or at the bottom.

The device 11 is fixed to the ski 10 so that the front end 24 of the lamina 12 and the rear end 27 of the lamina 13 can slide freely, while the rear end 25 of the lamina 12 and the front end 26 of the lamina 13 are fixed.

20 Holes 41 for fixing the toe unit 42 of a ski binding are arranged on the raised front portion 14 of the first lamina 12, whereas holes 43 for fixing the heel unit 44 of the binding are arranged on the rear portion 17 of the second lamina 13.

The binding is conveniently arranged so that the boot is at the center of gravity of the ski.

As regards use, when negotiating curves the ski, which is curved so that it cambers upward, flattens and thus reduces its convexity.

30

The result of this is that the end of each lamina 12 and 13 that is fixed to the ski moves with respect to the fixed end of the other lamina, following the flattening action, whereas the free ends of said laminae slide 5 longitudinally and compensate for it.

The same relative (center-of-gravity) position is thus maintained at all times between the boot and the ski, and thus the possibility to control said ski is always optimum.

If the device has elastic layers arranged between the 10 laminae, these layers furthermore absorb the vertical stresses applied to the ski by the unevenness of the snow-covered surface or by changes in the structural characteristics thereof.

In practice it has been observed that the intended aim 15 and objects of the present invention have been achieved.

The invention thus conceived is susceptible to numerous modifications and variations, all of which are within the scope of the inventive concept.

Thus, for example, the crossing of its laminae can be 20 provided even without intersection but for example between two tapered portions thereof arranged side by side.

As an alternative, it is possible to provide laminae that do not mutually cross but nonetheless are individually provided with a first fixed end and a second end that is 25 slideable along the ski.

The elements of the bindings may also be fixed in the vicinity of the fixed ends of the laminae.

It is also possible to make the laminae mutually interact by connecting them, for example, with a hydraulic 30 actuator that changes their possibilities of moving with

respect to each other according to the operating conditions, in order to adapt the response of the ski for example to changed conditions of the snow-covered surface (frozen, powdery, compact, etc.).

5 This change in movement can provide for a variation in the seepage rate between two chambers with hydraulic fluid due to the variation of a port that allows flow between them.

 Said hydraulic actuator can be controlled by sensors
10 which are located in various regions of the ski and are sensitive to the stresses applied thereto.

 Finally, it should be noted that in possible configurations the device according to the invention can be integrated in the structure of the ski and/or of the
15 bindings.

 All the details may furthermore be replaced with other technically equivalent elements.

 In practice, the materials employed, so long as they are compatible with the contingent use, as well as the
20 dimensions, may be any according to the requirements.

CLAIMS

1 1. Device for improving the efficiency and
2 controllability of skis, characterized in that it comprises
3 at least two elongated shaped plate-like elements (12, 13),
4 each element having one end (24, 27) provided with means
5 (36, 38, 39a) for fixing to a ski (10) and another end (25,
6 26) provided with retention means (36, 38, 39b) which allow
7 said other end (25, 26) to slide longitudinally with
8 respect to said ski (10), a toe unit (42) or heel unit (44)
9 of a ski binding being fixed proximately to one of said
10 ends (24-27).

1 2. Device according to claim 1, characterized in that
2 said at least two plate-like elements (12, 13) are
3 independent.

1 3. Device according to one or more of the preceding
2 claims, characterized in that said at least two plate-like
3 elements (12,13) are shaped so as to be both located in the
4 same region of the ski (10) so that the fixed end (24) of
5 one plate-like element (12) is arranged to the front and
6 the fixed end (27) of the other plate-like element (13) is
7 arranged to the rear.

1 4. Device according to one or more of the preceding
2 claims, characterized in that said at least two plate-like
3 elements (12, 13) at least partially overlap each other and
4 mutually cross.

1 5. Device according to one or more of claims 1 to 3,
2 characterized in that said at least two plate-like elements
3 (12, 13) are arranged at least partially side by side.

1 6. Device according to one or more of claims 1 and 3

2 to 5, characterized in that said at least two plate-like
3 elements (12, 13) are connected by means for controlling
4 their mutual movements.

1 7. Device according to claim 6, characterized in that
2 said control means are constituted by at least one
3 hydraulic actuator or equivalent device controlled by
4 sensors located on the ski.

1 8. Device according to one or more of the preceding
2 claims, characterized in that the regions of said at least
3 two plate-like elements (12, 13) where the bindings (42,
4 44) are mounted are raised with respect to the skis (10).

1 9. Device according to one or more of the preceding
2 claims, characterized in that said at least two plate-like
3 elements (12, 13) are combined with damping elements (21,
4 22, 23) arranged between said plate-like elements (12, 13)
5 and the skis (10).

1 10. Device according to one or more of the preceding
2 claims, characterized in that said at least two plate-like
3 elements (12, 13) are combined with damping elements (21,
4 22, 23) which are arranged between said plate-like elements
5 (12, 13), at least two of said damping elements (21, 22,
6 23) at least partially overlapping each other.

1 11. Device according to one or more of the preceding
2 claims, characterized in that said damping elements (21,
3 22, 23) are constituted by layers of elastic materials (21,
4 22, 23).

1 12. Device according to one or more of the preceding
2 claims, characterized in that said plate-like elements (12,
3 13) comprise two laminae (12, 13) having ends (24, 25, 26,
4 27), and portions (14, 15, 16, 17) which are raised with

5 respect to the surface for resting on the ski (10), each
6 lamina (12, 13) having two of said portions (14, 15, 16,
7 17) arranged at mutually different levels which are
8 connected by inclined regions (18, 19), one lamina (12)
9 having, in said inclined regions (18), a large longitudinal
10 slotted hole (20) which is crossed by the corresponding
11 inclined and appropriately tapered portion (19) of the
12 other lamina (13).

1 13. Device according to one or more of claims 1 to 11,
2 characterized in that it comprises two laminae (12, 13)
3 that mutually intersect at tapered portions (18, 19)
4 thereof which are arranged side by side.

1 14. Device according to one or more of the preceding
2 claims, characterized in that the ends (24, 25, 26, 27) of
3 said laminae (12, 13) are flat and that both the fixed ends
4 (24, 27) and the movable ends (25, 26) have longitudinal
5 slotted holes (32, 33, 34, 35) for fixing to the ski (10)
6 by means of screws (36), said screws (36) passing through
7 plates (37, 38) and elements (39) that are shaped so that
8 each one has a portion (39a) that is shaped complementarily
9 with respect to the profile of the slotted holes (32, 33,
10 34, 35) and a parallelepipedal portion (39b) that lies
11 centrally with respect to the complementarily-shaped
12 portion (39a), said portions (39a, 39b) being substantially
13 as thick as said laminae (12, 13), said shaped elements
14 (39) each locking one lamina with one of their portions
15 (39a) and leaving the other lamina free to move.

1 15. Device according to one or more of the preceding
2 claims, characterized in that said laminae (12, 13) have
3 holes (41, 43) for fixing a toe unit (42) and a heel unit

4 (44) of a ski binding.

1 16. Device according to one or more of the preceding
2 claims, characterized in that it is integrated in the
3 structure of the ski (10) and/or of the bindings (42, 44).

1 17. Device for improving the efficiency and
2 controllability of skis, comprising one or more of the
3 technical features described herein and/or illustrated in
4 the accompanying drawings.

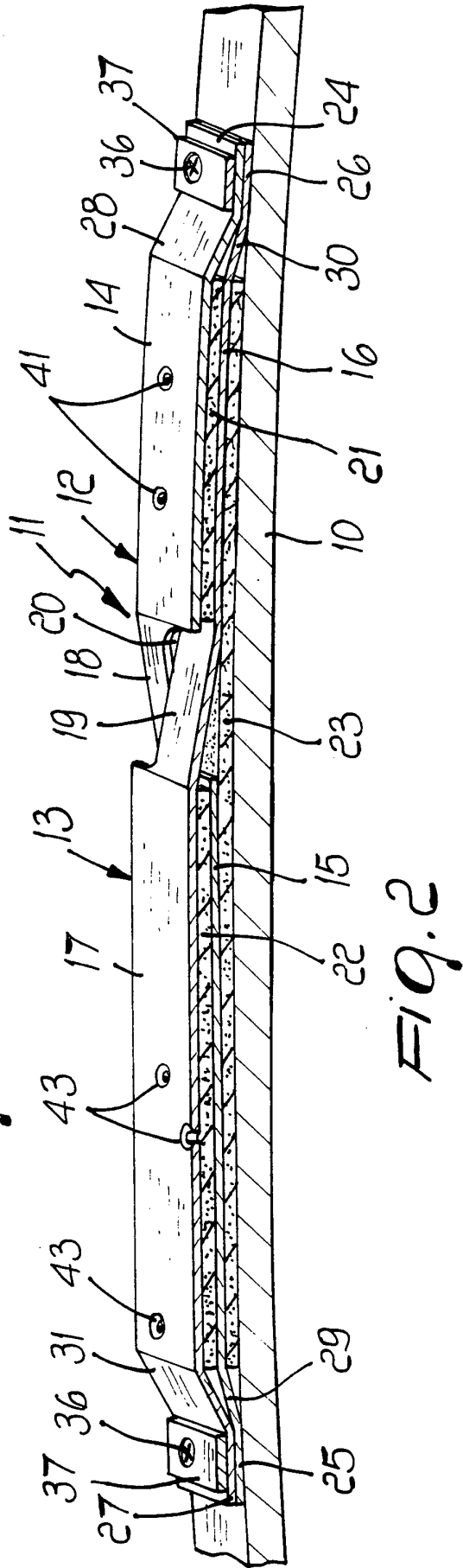
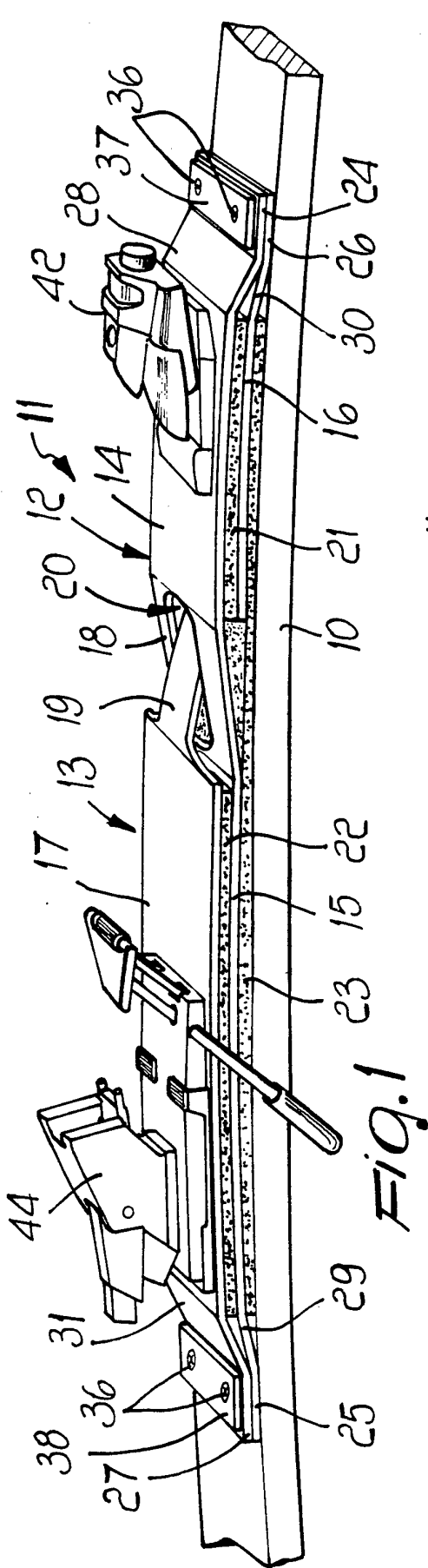

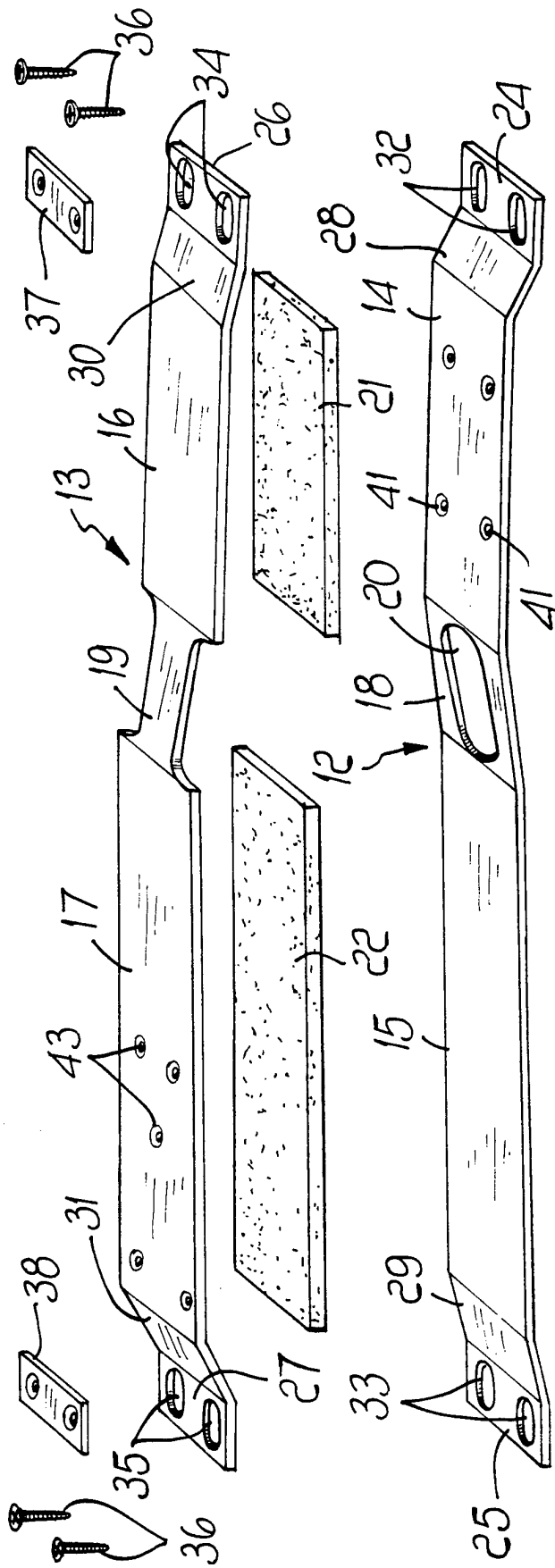
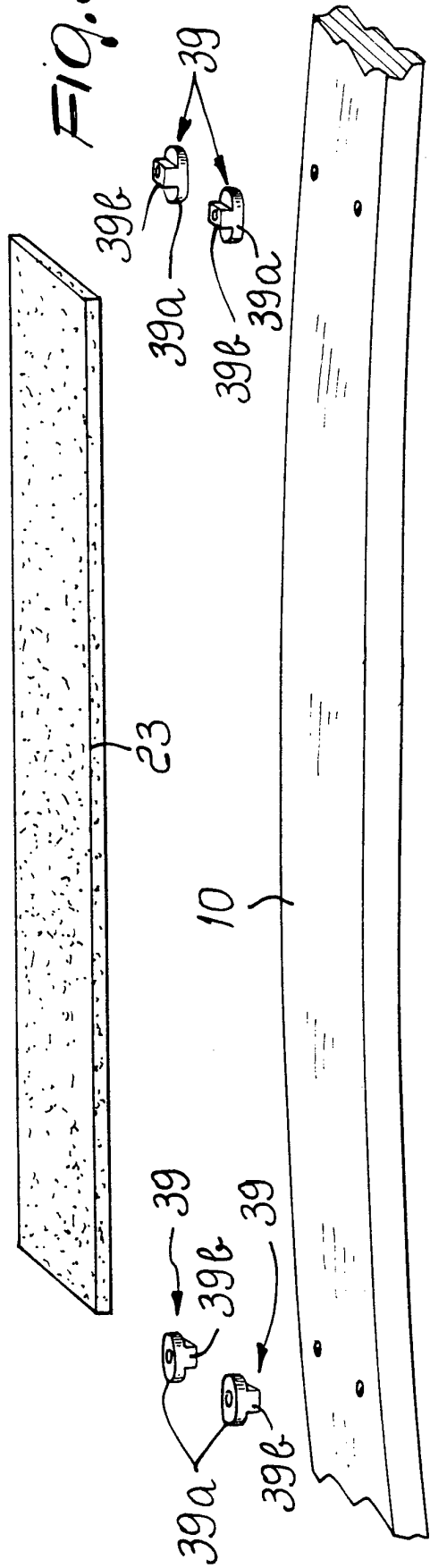

FIG. 3



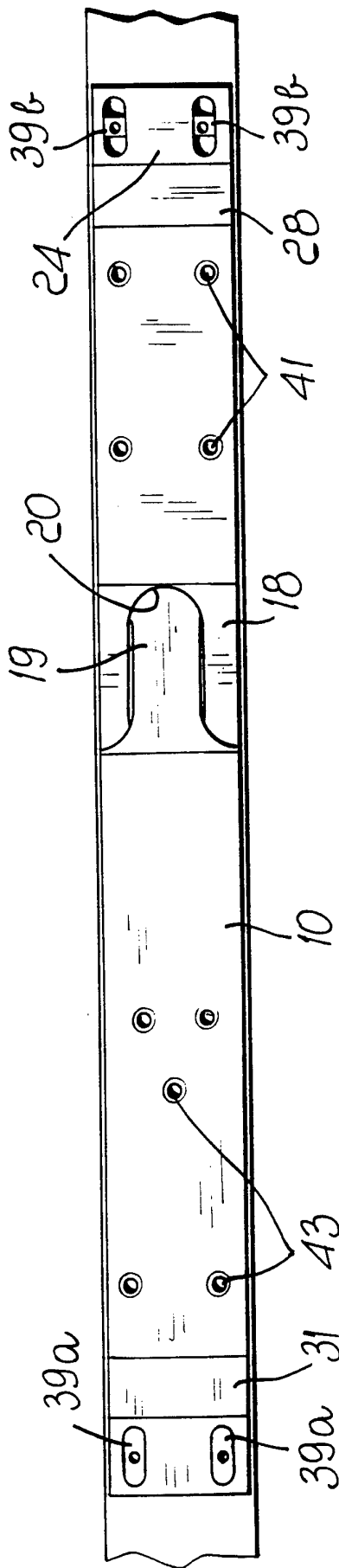

FIG. 4

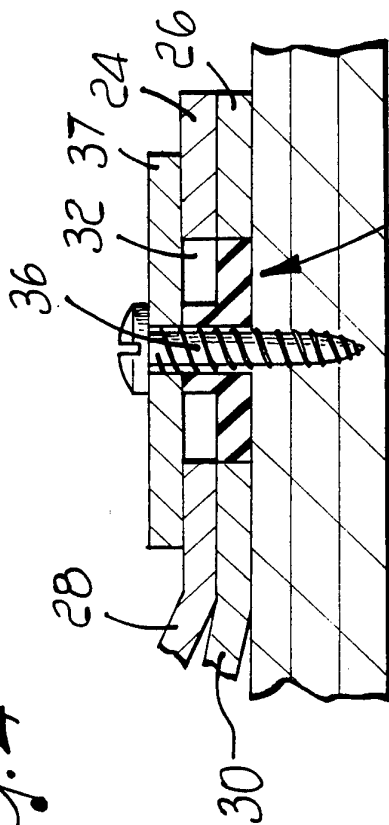

FIG. 5

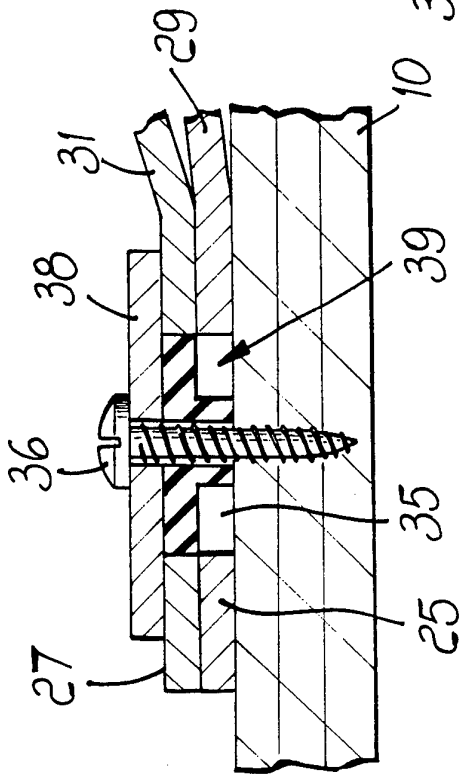

FIG. 6

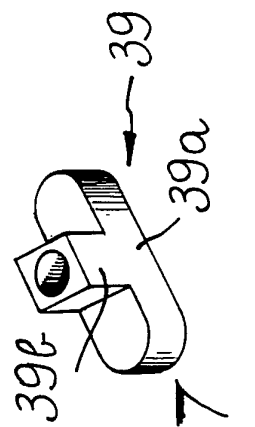

FIG. 7

INTERNATIONAL SEARCH REPORT

Inter. Application No

PCT/EP 94/03015

A. CLASSIFICATION OF SUBJECT MATTER
IPC 6 A63C5/07

According to International Patent Classification (IPC) or to both national classification and IPC

B. FIELDS SEARCHED

Minimum documentation searched (classification system followed by classification symbols)

IPC 6 A63C

Documentation searched other than minimum documentation to the extent that such documents are included in the fields searched

Electronic data base consulted during the international search (name of data base and, where practical, search terms used)

C. DOCUMENTS CONSIDERED TO BE RELEVANT

Category *	Citation of document, with indication, where appropriate, of the relevant passages	Relevant to claim No.
X	EP,A,0 510 308 (SALOMON S.A.) 28 October 1992	1-4,8,9, 11,15,17
Y	see claims 1-3,7,8; figures 13,21,29	6,7,16
Y	FR,A,2 626 485 (SALOMON S.A.) 4 August 1989 see figures 1,9	6,7
Y	FR,A,2 654 635 (SALOMON S.A.) 24 May 1991 see page 6, line 1	16
A	DE,A,22 46 668 (VEREINIGTE BAUBESCHLAGFABRIKEN GRETSCH & CO GMBH) 11 April 1974 see figure 2	5

 Further documents are listed in the continuation of box C. Patent family members are listed in annex.

* Special categories of cited documents :

"A" document defining the general state of the art which is not considered to be of particular relevance

"E" earlier document but published on or after the international filing date

"L" document which may throw doubts on priority claim(s) or which is cited to establish the publication date of another citation or other special reason (as specified)

"O" document referring to an oral disclosure, use, exhibition or other means

"P" document published prior to the international filing date but later than the priority date claimed

"T" later document published after the international filing date or priority date and not in conflict with the application but cited to understand the principle or theory underlying the invention

"X" document of particular relevance; the claimed invention cannot be considered novel or cannot be considered to involve an inventive step when the document is taken alone

"Y" document of particular relevance; the claimed invention cannot be considered to involve an inventive step when the document is combined with one or more other such documents, such combination being obvious to a person skilled in the art.

"&" document member of the same patent family

Date of the actual completion of the international search

16 December 1994

Date of mailing of the international search report

03.01.95

Name and mailing address of the ISA

European Patent Office, P.B. 5818 Patentlaan 2
NL - 2280 HV Rijswijk
Tel. (+31-70) 340-2040, Tx. 31 651 epo nl,
Fax: (+31-70) 340-3016

Authorized officer

Papa, E

INTERNATIONAL SEARCH REPORT

information on patent family members

International Application No PCT/EP 94/03015
--

Patent document cited in search report	Publication date	Patent family member(s)	Publication date
EP-A-0510308	28-10-92	FR-A- 2675392 AT-T- 112499 DE-D- 69200489 JP-A- 6098962	23-10-92 15-10-94 10-11-94 12-04-94
FR-A-2626485	04-08-89	AT-A, B 10789 DE-A- 3901623 JP-A- 1223983	15-09-93 03-08-89 07-09-89
FR-A-2654635	24-05-91	NONE	
DE-A-2246668	11-04-74	FR-A- 1464104	