

(19)  
(12)

(KR)  
(A)

(51) 。 Int. Cl.7  
A47L 9/24

(11)  
(43)

10-2004-0009538  
2004 01 31

(21) 10-2002-0043526  
(22) 2002 07 24

(71) 1398 LG 118 701

(72) 1398 LG 118 701

(74)

:

(54)

가 가 , / ,

(20) (10) (11) (11a) (20) ,  
(30) (11) (11b) (20) (40)  
(10(10')) 1 (10) (20) (20) (20)  
a) 2 (10') (30)가 (30) / (20)  
(20a) (30) (30a)

2

1-

2-

3-

4-

5-

1: 10: 1 10': 2

11: 11a: 11b:

12: 13: 20:

20a: 30: 30a:

40: 40a:

,가

가

/

가

가 (圓形)

가

가

가

가  
가

가

가  
가

가

가

가  
가

가 가 가

[ 2 ] (20) (40) (30) (30)가 (30a) (10) (11) (11b) (30) (10)(10') (11a) (20) (30) (1) (20a) / (20) (20a)

2 [ 4 ] (20) (40) [ 3 ] (40a) 가 [ 5 ] (40)

(40) [ 3 ] (40) 가 가 (銅線) (20) (10) (40a) [ 4 ] (40) 가 [ 5 ] (40) (11) (20) (20) (40)

(11) (20)가 (11) (20)가 (10) (20) (1)가 (20) (11) (20) (30) (1) (20) (20a) (30) (11) (12) (13) 가 가 가 가 (1) (40) (40) (1) (40) (20) (11) (20) 가 가 가 (1) (40) (40) (40a)

(57)

1.

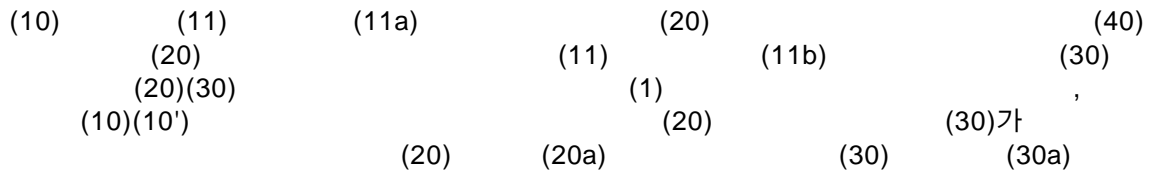

2.

1



3.

1



4.

1



1

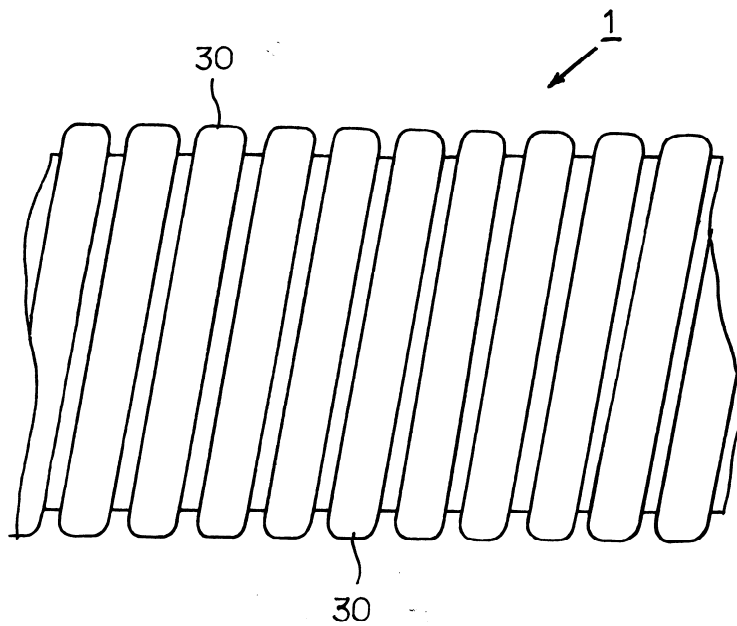

2

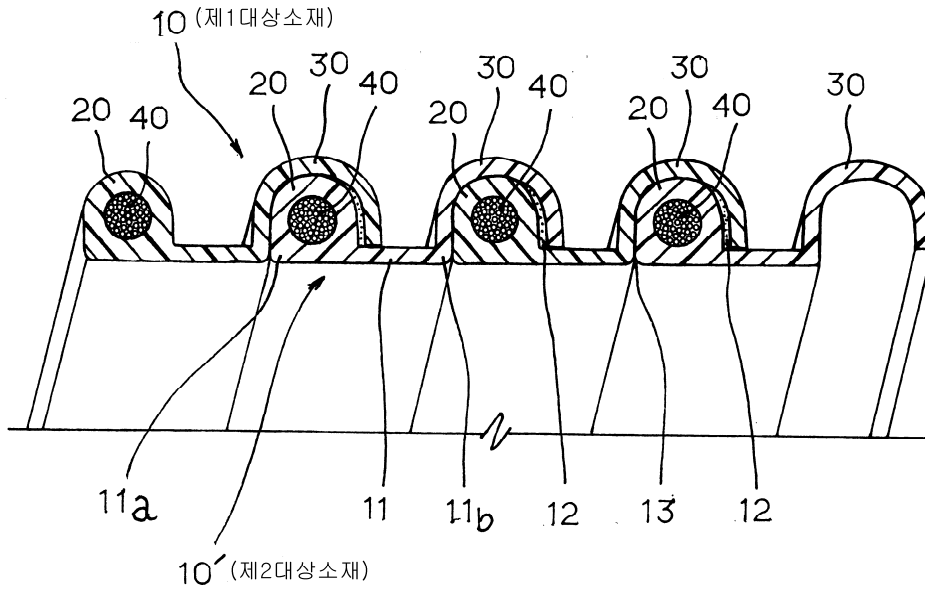

3

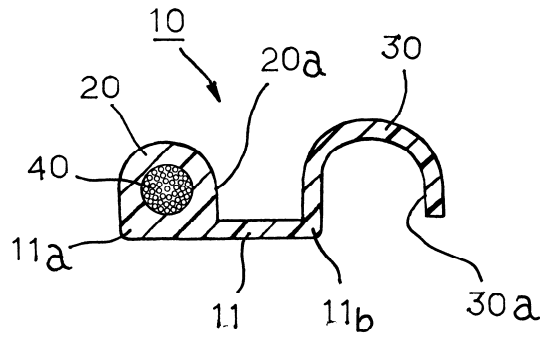

4

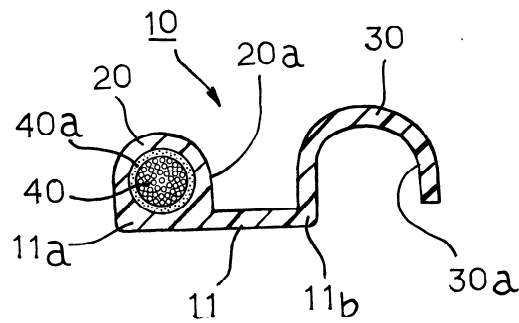

5

