

(19) World Intellectual Property Organization
International Bureau



(43) International Publication Date
16 January 2003 (16.01.2003)

PCT

(10) International Publication Number
WO 03/005095 A2

- (51) International Patent Classification⁷: **G02B 6/44**
- (21) International Application Number: PCT/US02/19981
- (22) International Filing Date: 20 June 2002 (20.06.2002)
- (25) Filing Language: English
- (26) Publication Language: English
- (30) Priority Data:
09/900,465 6 July 2001 (06.07.2001) US
- (71) Applicant: **ADC TELECOMMUNICATIONS, INC.**
[US/US]; 13625 Technology Drive, Eden Prairie, MN
55344-2252 (US).
- (72) Inventors: **DOUGLAS, Joel, B.**; 159 Elk Drive, Hutchin-
son, MN 55350 (US). **BARNES, Kathleen, M.**; 9613
Lakeside Trail North, Champlin, MN 55316 (US).
FRANKLIN, Michael, J.; 12725 Ethelton Way, Apple
Valley, MN 55124 (US). **HANNAH, Lonnie, E.**; 9176
Farmstead Avenue, Monticello, MN 55362 (US). **SMITH,
Trevor, D.**; 6712 West 26th Street, St Louis Park, MN
55426 (US). **TREBESCH, Steven, P.**; 616 Lantern Ct.,
Eagan, MN 55123 (US).
- (74) Agent: **BRUESS, Steven, C.**; Merchant & Gould P.C.,
P.O. Box 2903, Minneapolis, MN 55402-0903 (US).
- (81) Designated States (*national*): AE, AG, AL, AM, AT (util-
ity model), AT, AU, AZ, BA, BB, BG, BR, BY, BZ, CA,
CH, CN, CO, CR, CU, CZ (utility model), CZ, DE (util-
ity model), DE, DK (utility model), DK, DM, DZ, EC, EE
(utility model), EE, ES, FI (utility model), FI, GB, GD, GE,
GH, GM, HR, HU, ID, IL, IN, IS, JP, KE, KG, KP, KR, KZ,
LC, LK, LR, LS, LT, LU, LV, MA, MD, MG, MK, MN,
MW, MX, MZ, NO, NZ, OM, PH, PL, PT, RO, RU, SD,
SE, SG, SI, SK (utility model), SK, SL, TJ, TM, TN, TR,
TT, TZ, UA, UG, UZ, VN, YU, ZA, ZM, ZW.
- (84) Designated States (*regional*): ARIPO patent (GH, GM,
KE, LS, MW, MZ, SD, SL, SZ, TZ, UG, ZM, ZW),
Eurasian patent (AM, AZ, BY, KG, KZ, MD, RU, TJ, TM),
European patent (AT, BE, CH, CY, DE, DK, ES, FI, FR,
GB, GR, IE, IT, LU, MC, NL, PT, SE, TR), OAPI patent
(BF, BJ, CF, CG, CI, CM, GA, GN, GQ, GW, ML, MR,
NE, SN, TD, TG).
- Published:**
— *without international search report and to be republished
upon receipt of that report*
- For two-letter codes and other abbreviations, refer to the "Guid-
ance Notes on Codes and Abbreviations" appearing at the begin-
ning of each regular issue of the PCT Gazette.*



WO 03/005095 A2

(54) Title: CABLE MANAGEMENT PANEL WITH SLIDING DRAWER AND METHODS

(57) Abstract: An optical fiber cable management panel includes drawer assemblies, each including a drawer slidable within a chassis. The drawer assemblies are secured together by a bracket that includes an interlock arrangement with the chassis. Such an interlock arrangement includes a non-threaded stud engaging a hole. Radius limiters may be part of the drawer assembly and include a cable entry aperture have a closed perimeter and a flared cable guide surface around most of, and preferably all of, the closed perimeter to allow for the entry of cables from all directions. A control mechanism controls movement of the radius limiter relative to the drawer assembly. The control mechanism includes a rotating member that has an axis of rotation transverse to the slidable motion of the radius limiter and normal to the radius limiter.

**CABLE MANAGEMENT PANEL WITH SLIDING DRAWER
AND METHODS**

This application is being filed as a PCT International Patent Application in the name of ADC Telecommunications, Inc., a U.S. national corporation and
5 resident, on 20 June 2002, designating all countries except US, and claiming priority to U.S. Serial No. 09/900,465 filed on 06 July 2001.

Technical Field

This disclosure concerns management of optical fiber cables. In particular, this disclosure relates to storage of optical fiber cables and devices in the
10 telecommunications industry.

Background of the Invention

Cable termination, splice, and storage devices are known including, for example, devices shown in U.S. Patent Nos. 4,792,203 and 5,946,440, both assigned to ADC Telecommunications, Inc. Both of these patents concern devices
15 with movable trays for storage and management of the optical fiber cables. U.S. Patent No. 5,066,149, also assigned to ADC Telecommunications, concerns a cable management device including slidable drawers, each including a cable slack take-up mechanism. When moving the trays or drawers, unnecessary or excessive displacement of the optical fiber cables is undesirable. As the optical fiber cables
20 are displaced, they are subject to bending and other forces. Bending of the fibers can cause attenuation and loss of signal strength. As the fiber bends, the fiber can also break, resulting in a loss of transmission through the fiber. Improvements are desirable.

Summary of the Invention

25 In one aspect, the disclosure describes a radius limiter for an optical fiber cable management panel. The radius limiter includes a frame piece having a vertically oriented curved wall and a trough section adjacent to the curved wall. A cover member is oriented at least partially over the trough section. The cover member and the frame piece define a cable entry aperture having a closed perimeter.
30 The cable entry aperture is in communication with the trough section to permit

cables to enter through the aperture and rest within the trough section. Further, at least 75% of the perimeter of the cable entry aperture is circumscribed by a flared cable guide surface.

5 A method of limiting a radius of optical fiber cables is provided and includes directing optical fiber cables through a cable entry aperture and against a flared cable guide surface of a cover. The cover is oriented at least partially over a trough section of a frame piece that is part of a radius limiter.

10 In another aspect, this disclosure concerns an optical fiber cable management system including at least first and second drawer assemblies. Each of the drawer assemblies includes a chassis and a drawer slidably mounted within the chassis. A mounting bracket is provided to connect together the first drawer assembly and the second drawer assembly through an interlock arrangement. The mounting bracket also is usable to connect together more than two drawer assemblies. The interlock arrangement includes non-threaded stud members and
15 holes sized for receiving the non-threaded stud members.

A method of connecting a first drawer assembly to a second drawer assembly includes securing a bracket to the chassis of the first drawer assembly and the chassis of the second drawer assembly by inserting a non-threaded stud arrangement into an aperture arrangement.

20 In another aspect, this disclosure is directed to an optical fiber cable management panel including a drawer assembly, including a drawer slidably mounted within a chassis, a cable radius limiter slidably mounted relative to the drawer assembly, and a control mechanism secured to the drawer assembly to synchronize slidable movement of the cable radius limiter relative to slidable
25 movement of the drawer within the chassis. The control mechanism includes a rotating member oriented to rotate between the drawer and the chassis. The rotating member has an axis of rotation that is transverse to a direction of slidable movement of the cable radius limiter.

30 A method for controlling slidable movement of a cable radius limiter relative to slidable movement of a drawer within a chassis includes rotating a wheel, secured to the cable radius limiter, between the drawer and the chassis. The wheel has an axis of rotation that is oriented normally to the cable radius limiter.

Brief Description of the Drawings

FIG. 1 is a perspective view of a cable management panel, depicting two drawers and without tray inserts;

FIG. 2 is a perspective view of a radius limiter utilized in the cable management panel depicted in FIG. 1;

FIG. 3 is a top plan view of the radius limiter depicted in FIG. 2;

FIG. 4 is a front elevational view of the radius limiter depicted in FIG. 2;

FIG. 5 is a right side elevational view of the radius limiter depicted in FIG. 2;

FIG. 6 is a perspective view of a cover utilized on the radius limiter of FIG. 2 and showing a cover on the radius limiter pivoted to allow access to a trough in the radius limiter;

FIG. 7 is a top plan view of a cover for the radius limiter depicted in FIG. 2;

FIG. 8 is a front elevational view of the cover depicted in FIG. 7;

FIG. 9 is a right elevational view of the cover depicted in FIG. 7;

FIG. 10 is a side elevational view of the cable management panel depicted in FIG. 1;

FIG. 11 is a schematic, partially cross-sectional view of the cable management panel depicted in FIG. 1, the cross-section being taken along the line 11-11 of FIG. 10;

FIG. 12 is a perspective view of a bracket utilized to secure together the drawers of the cable management panel depicted in FIGS. 1 and 10;

FIG. 13 is a top plan view of a chassis that is part of a drawer assembly utilized in the cable management panel depicted in FIG. 1;

FIG. 14 is a perspective view of the chassis of FIG. 13;

FIG. 15 is a perspective view of the cable management panel depicted in FIG. 1, and with one of the drawers in a fully open position and with one drawer in a partially open position;

FIG. 16 is a side elevational view of the cable management panel depicted in FIG. 15, and with a portion broken away to show internal components;

FIG. 17 is an exploded, perspective view of one of the drawer assemblies depicted in FIG. 15;

FIG. 18 is a top plan view of the cable management panel depicted in FIG. 15;

5 FIG. 19 is a schematic, cross-sectional view of the cable management panel taken along the line 19-19 of FIG. 18;

FIG. 20 is a perspective view of a wheel bracket utilized in the cable management panel depicted in FIGS. 1 and 15-19; and

10 FIG. 21 is a side elevational view of the wheel bracket depicted in FIG. 20.

Detailed Description of the Preferred Embodiment

A cable management panel or module is depicted in FIG. 1 generally at 30. In the one shown, the panel 30 includes a plurality of drawer assemblies 32. In the one shown in FIG. 1, the panel 30 includes two drawer assemblies 32. Each of the drawer assemblies 32 includes a chassis 34 and a drawer 36 slidably mounted within the chassis 34.

Each drawer 36 may include cable management structure, for example, devices for storing the cables or connecting the cables to other cables or fiber optic devices, such as attenuators, couplers, switches, wave division multiplexers, splitters or splices. Drawers 36 are slidable relative to chassis 34 by way of two drawer slides 38 on opposite sides of the chassis 34. Each drawer 36 includes two latches 40 to secure the drawer 36 in a closed position (the position shown in FIG. 1).

Each drawer 36 includes a base 42, a front wall 44 and a rear wall 46. Note that the drawer 36 is absent of side walls, or is "side wall-free." This structure allows for cable entry and exit and prevents cable damage during sliding movement of the drawers 36 when accessing the cables and connectors or other devices in the drawer 36. The base 42, front wall 44 and rear wall 46 together define a storage interior 48 for holding and storing the cables.

30 Each storage interior 48 is sized for receiving cable management and/or distribution structures. When the drawer 36 is in the closed position, the cables and management or distribution structures in the storage interior 48 are

protected. In preferred embodiments, the distribution structures can be conveniently mounted on a tray insert that drops into the storage interior 48. This allows for convenient structuring of the drawer 36 to serve one or more desired functions in the panel 30. Examples of tray inserts are described in co-pending and commonly
5 assigned U.S. Patent Application Serial No. 09/649,398, which is a continuation-in-part of Application Serial No. 09/490,379 (also co-pending and commonly assigned), each of which is incorporated by reference herein. In the preferred embodiment illustrated, each of the drawers 36 is constructed to be stackable and linkable to form sub-cable management panels 31. Such modularity also allows for
10 ease of use for a variety of different needs for the cable management system. As can be seen in FIG. 1, a bracket 50 is used to link each of the drawer assemblies 32 together. A perspective view of one preferred embodiment of the bracket 50 is illustrated in FIG. 12

In prior arrangements, mounting brackets were attached to the side
15 chassis with each drawer with several screws, for example, #4-40 UNC screws. It was found that if drawers connected together in this manner were dropped, the bracket would become loose from the drawers, leading to wobble between drawers in a multiple drawer assembly. Further, when the drawers would be opened, there sometimes would be rubbing and scraping if the drawers were loose from the
20 bracket. The bracket 50, as described herein, addresses these problems.

In particular, the mounting bracket 50 connects together each of the drawer assemblies 32 through an interlock arrangement 52. In preferred
embodiments, the interlock arrangement 52 includes at least one, and preferably a plurality, of non-threaded stud members 54 located in one of the mounting bracket
25 50 and the chassis 34. Further, the interlock arrangement 52 includes at least one, and preferably a plurality, of apertures or holes 56 sized for receiving the non-threaded stud members 54. The plurality of holes 56 are defined by the other of the mounting bracket 50 and the chassis 34.

In the particular embodiment illustrated, the interlock arrangement 52
30 includes two non-threaded stud members 54 projecting from the chassis 34 (see FIGS. 13-14). The stud members 54 may be formed from the chassis 34 itself (by punching or forming), or may be independent members permanently secured to the chassis 34. In this illustrated embodiment, the interlock arrangement 54 includes at

least 4 holes being defined by the mounting bracket 50, receiving each of the non-threaded stud members 54 of each of the chassis 34. These holes 56 are visible in FIGS. 10 and 12.

In general, the bracket 50 includes first and second mounting plates 5 60, 61 arranged generally orthogonal to each other. The first mounting plate 60 is utilized for securing each of the chassis 34 together. The second mounting plate 61 is used to mount each of the drawer assemblies 32 together along other framework, typically together with other cable management panels 30. Each of the holes 56 is defined by and extends completely through the first mounting plate 60. The first 10 mounting plate 60 also includes several more holes 62 for accommodating screws 64, as used in prior arrangements, to help secure each of the drawer assemblies 32 together to the bracket 50.

The chassis 34 is illustrated in FIGS. 13 and 14. It can be seen that each chassis generally is an L-shaped frame piece 66 and, in addition to the non- 15 threaded studs 54 projecting from the frame piece 66, defines a plurality of holes 68 for accommodating the screws 64.

FIG. 11 is a cross-sectional view illustrating the bracket 50 secured to one of the chassis 34. Two of the studs 54 can be seen in cross-section extending through two of the holes 56. This interlock arrangement 52 provides the cable 20 management panel 30 with more strength and rigidity than prior arrangements that utilized screws. The interlock arrangement 52 helps to absorb the impact and thrust loading created by a drop scenario, by vibration, or by an earthquake.

While non-threaded stud members 54 are illustrated in the preferred embodiment, it should be understood that, in alternate arrangements, pins may also 25 be used. Further, in other embodiments, the interlock arrangement 52 may include a tab/slot arrangement, where a tab projects into and is bent over a slot.

Preferably, each of the drawer assemblies 32 includes a take-up mechanism 70 to manage optical fibers entering and exiting the cable management panel 30. In the preferred embodiment illustrated, each take-up mechanism 70 30 includes a push member or radius limiter 72. In reference now to FIG. 2, one preferred embodiment of radius limiter 72 is illustrated in perspective view. In the preferred one shown, the radius limiter 72 includes a frame piece 74. The frame piece 74 includes a vertically oriented curved wall 76 and a trough section 78

adjacent to the vertically curved wall 76. In particular, the trough section 78 is defined by a second vertically oriented wall 80 and a base 82 that bridges the vertically oriented wall 80 and the curved wall 76 (see FIG. 3). As can be seen in FIGS. 2 and 3, the curved wall 76 is concavely shaped relative to the trough section 78. As can also be seen in FIG. 3, the trough section 78 also has a curved shape. In preferred embodiments, the curved shape of the trough section 78 is on a radius of about 1.25 - 2 in.

Still in reference to FIG. 2, the preferred radius limiter 72 shown includes a cover member 84. Preferably, the cover member 84 is oriented at least partially over the trough section 78. The cover member 84 and the frame piece 74 define a cable entry aperture 86 that is in communication with the trough section 78 to permit cables to enter through the aperture 86 and rest within the trough section 78.

The cable entry aperture 86 defines a closed perimeter 88. By "closed perimeter", it is meant that the border that forms the aperture 86 is at least 90%, preferably 100%, closed to form a continuous, uninterrupted boundary. In the preferred embodiment illustrated, at least 75%, preferably at least 95%, and in most preferred embodiments, 100% of the perimeter 88 of the cable entry aperture 86 is circumscribed by a flared cable guide surface 90. The flared cable guide surface 90 preferably takes the form of a smooth, contour 92, such that the cable entry aperture 86 has the appearance of a trumpet flare or a bell-mouth 94. The smooth contour 92 preferably is bent on a radius of about 0.25 - 0.75 in. The flared cable guide surface 90 helps to protect cables entering the cable entry aperture 86 and prevents such cables from bending too sharply and possibly losing some light transmission.

As can be seen particularly in FIGS. 2 and 5, the preferred embodiment has the entire perimeter 88 of the cable entry aperture 86 to include the flared cable guide surface 90. When shaped in this manner, the cable entry aperture 86 protects cables entering from any direction, including from a direction vertically above the radius limiter 72.

In reference now to FIGS. 6-9, features of the cover member 84 are defined. Preferably, the cover member 84 includes a finger 96. The finger 96 includes an extension 97 that defines a first free edge 98 and a second free edge 99. A stem 102 extends between the extension 97 and an attachment portion 104. As

can be seen in FIGS. 6-9, the first free edge 98 defines a portion of the flared guide surface 90. The second free edge 99 selectively engages the vertically oriented wall 76 of the frame piece 74 through a latch arrangement 106 (FIGS. 2 and 4). Preferably, the latch arrangement 106 includes a hook and projection arrangement 5 108, where a hook from one of the finger 96 and frame piece 74 engages a projection from the other of the finger 96 and frame piece 74. In the particular arrangement illustrated, the latch arrangement 106 includes the finger 96 having a hook 110 defining an aperture 111, through which a projection 112 extending or projecting from the vertically oriented curved wall 76 of the frame piece 74 is 10 defined. As can be appreciated, the latch arrangement 106 permits the finger 96 to be releasably secured to the frame piece 74. Together with the attachment portion 104, explained below, this latch arrangement 106 permits the finger 96 to be selectively moved from, and pivoted at the attachment portion 104, from the frame piece 74 to permit the installation of cables through the cable entry aperture 86 and 15 into the trough section 78.

The attachment portion 104 helps to pivotally secure the finger 96 to the frame piece 74. In reference to FIGS. 6 and 8, in the preferred embodiment, the attachment portion 104 includes a pair of extruding tabs 114, 116, projecting from the extension 97. The tabs 114, 116 are snapped around a member 75 within the 20 frame piece 74 of the radius limiter 72 in a manner which allows the frame piece 74 to securely hold the finger 96 and permit the finger 96 to be selectively pivoted away from and then back toward the trough section 78 (see FIG. 6), along a hinge point 118.

The latch arrangement 106 provides for a secure interlock between 25 the finger 96 and the frame piece 74 to prevent unintended bending away of the finger 96 from the frame piece 74 if fibers or cables tend to pull it up during manipulation of the drawer assembly 32. In preferred embodiments, the hinge point 118 permits selective lifting of the cover member 84 away from remaining portions of the radius limiter 72 to facilitate fiber loading.

30 The cover member 84 may also include a second finger 100 (FIGS. 11 and 18). Finger 100, in the one shown, is oriented generally at a right angle to the finger 96 and is pivotally mounted relative to the frame 74. Finger 100 also helps to hold the cables in place within the radius limiter 72.

To load cable or fiber into the radius limiter 72, the latch arrangement 106 is released to allow the finger 96 to be moved relative to the frame 74. The finger 96 is pivoted about the hinge point 118 that defines a gap or space through which the cable may enter. If present, the second finger 100 is also pivoted
5 away from the frame 74. The cable is then oriented and rested within the trough section 78. The finger 96 is again oriented against the frame piece 74 to close the gap or space, and the latch arrangement 106 is secured by having the projection 112 extend into the aperture 111 of the hook 110. If present, the second finger 100 is returned against the frame 74. If cable is being directed from a position above the
10 radius limiter 72, the cable is resting against the flared cable guide surface 90 defined by the first free edge 98 of the finger 96. As described above, the flared cable guide surface 90 helps to prevent the cable from bending too sharply. Further, as explained above, the shape of the trough section 78 also controls the radius of the cable and prevents it from bending too sharply.

15 The radius limiter 72 is preferably slidably mounted relative to the drawer assembly 32. Movement of the radius limiter 72 is controlled with synchronized movement with the drawer 36 to ensure that the cables do not bend too sharply when the drawer 36 is being opened or closed relative to the chassis 34. If the cables were bent too sharply, this may cause loss of signal strength or loss of
20 transmission. Preferably, the cable management panel 30 includes a control mechanism 125 (FIGS. 15-19) that is secured to the drawer assembly 32 to synchronize slidable movement of the cable radius limiter 72 relative to slidable movement of the drawer 36 within the chassis 34. In particular, the control mechanism 125 includes a rotating member 126, such as a roller or wheel 128.
25 Preferred wheels 128 will include a compressible ring 129 (FIG. 17) that circumscribes the wheel 128 to help provide for a smooth interface and introduce some friction for smooth operation.

Preferably, the wheel 128 is oriented to rotate between the drawer 36 and the chassis 34. In most preferred embodiments, the wheel 128 has an axis of
30 rotation 130 that is transverse to a direction of slidable movement of the cable radius limiter 72. This is illustrated in FIG. 16. In FIG. 16, the direction of slidable movement of the cable radius limiter 72 is shown at arrow 132. In the particular orientation shown in FIG. 16, this direction 132 is a horizontal direction. It is also

the direction that corresponds to the slidable motion of the drawer 36 relative to the chassis 34. The axis of rotation 130 extends, in the particular orientation shown in FIG. 16, in a vertical direction, that is, the direction transverse to the direction 132 of slidable movement of the radius limiter 72. Also, in the example illustrated, the axis of rotation 130 is normal (i.e., perpendicular) to the radius limiter 72. By having the wheel 128 rotate about axis 130, which is a direction transverse to the motion of the radius limiter 72 and normal to the radius limiter 72, there is a reduction in problems associated with assembly during manufacturing. For example, in previous arrangements, the wheel was oriented to have an axis of rotation that extended parallel to the radius limiter 72. In these prior arrangements, sheet metal flatness and parallelism had to be carefully controlled because it was critical to wheel engagement. Further, in these previous systems when the wheel had an axis of rotation that was parallel to the radius limiter, there was an issue with respect to tolerance stack up. Further, in prior systems, the wheels would push the drawer and its components upwards towards the drawer cover due to the orientation of the wheel, which sometimes caused interference problems. By orienting the wheel 128 with the axis of rotation 130 in the direction normal to the radius limiter, many of these problems are addressed or eliminated all together.

In reference now to FIGS. 20-21, in preferred embodiments, the control mechanism 125 includes a bracket 134 having an axle 136. As can be seen in FIGS. 20 and 21, the wheel 128 is mounted for rotation on the axle 136. The axle 136 is co-linear with and defines the axis of rotation 130.

Still in reference to FIGS. 20-21, the preferred bracket 134 shown includes a projection arrangement 138 that allows the bracket 134 to be secured to the cable radius limiter 72. In particular, the projection arrangement 138 includes a first projection 140 and a second projection 142. Each of the first projection 140 and second projection 142 includes a tab 144, 145 that extends or projects into and locks with a suitable receiving aperture 146, 147 (FIG. 17) in the frame piece 74 of the radius limiter 72. In this manner, the bracket 134 can be secured to the radius limiter 72, and through an elongated slot 150 defined by the base 42 of the drawer 36. The slot 150 allows for assembly of the radius limiter 72 to the drawer 36.

The bracket 134 also includes a catch 152 projecting from a side and in a direction opposite to the direction that the projection arrangement 138 projects.

In the one shown, the catch 152 defines one end 154 of the bracket 134. Also, in the particular embodiment illustrated, the first projection 140 forms an opposite end 156 of the bracket 134. The catch 152 is selectively engaged with a stop member 158 on the chassis 34. The catch 152 of the bracket 134 selectively engages the stop
5 member 158 when the drawer 36 and the radius limiter 72 are slid relative to the chassis 34. This engagement prevents the drawer 36 from being totally separated from the chassis 34 when sliding the drawer 36 from the chassis 34.

In reference again to FIG. 17, the chassis 34 was described above as being an L-shaped frame piece 66. In particular, the L-shaped frame piece 66
10 includes a base 160 that is located in a plane generally parallel to the base 42 of the drawer, when the drawer assembly 32 is in operable assembly, and a side wall 162 extending normal to the chassis base 160. This side wall 162 provides one of the surfaces against which the wheel 128 rotates.

Secured to the drawer 36 is a wheel guide 164. The wheel guide 164
15 is a generally elongated structural member defining a smooth guide surface 165. As can be seen in FIGS. 15 and 17, the wheel guide 164 is adjacent to and generally parallel to the elongated slot 150 in the drawer 36.

In operable assembly, the wheel 128 rotates about its axle 136
20 between and against the guide surface 165 of the wheel guide 164 and the chassis side wall 162. The location of the wheel 128 secured to the radius limiter 72 and between the drawer 36 and chassis 34 allows the radius limiter 72 to move at one-half of the speed of the movement of the drawer 36 relative to the chassis 34.

In reference again to FIG. 17, and as mentioned above, each of the
25 drawer assemblies 32 preferably includes drawer slide 38. The drawer slide 38 is the type of slide that is described in U.S. Patent No. 5,209,572, which is incorporated by reference herein. In general, the drawer slide 38 includes symmetrically identical outside channel members 167, 168 for securing to the drawer 36 and chassis 34, respectively. An inner retainer 169 slidably retains ball bearings (not shown) that are trapped between the channel members 168, 169. In
30 operation, when the drawer 36 is moved relative to the chassis 34, the channel member 167 slides relative to the channel member 168 with the ball bearings rotating between the retainer 169 and the channel members 167, 168 to help create smooth, slidable motion.

When the drawer 36 is slid relative to the chassis 34, the wheel 128 is rotated between the drawer 36 and chassis 34 (in particular, between the wheel guide 164 and the side wall 162 of the chassis 34), and the wheel 128 is rotated about the axis of rotation 130 that is transverse to the direction of slidable movement of the
5 cable radius limiter 72, and that is oriented normally to the radius limiter 72.

The above specification provides a complete description of example embodiments of the invention. Many embodiments of the invention can be made, according to principles described herein.

WE CLAIM:

1. A radius limiter (72) for an optical fiber cable management panel (30); the radius limiter comprising a frame piece (74) including a vertically oriented curved wall (76); and a trough section (78) adjacent to said curved wall; said curved wall being concavely shaped relative to said trough section; the radius limiter characterized by:
 - (a) a cover member (84) is oriented at least partially over the trough section;
 - (i) said cover member and said frame piece defining a cable entry aperture (86) having a closed perimeter (88);
 - (A) said cable entry aperture being in communication with said trough section (78) to permit cables to enter through the aperture and rest within the trough section;
 - (B) at least 75% of said perimeter of said cable entry aperture being circumscribed by a flared cable guide surface (90).
2. A radius limiter according to claim 1 wherein:
 - (a) all of said perimeter of said cable entry aperture is circumscribed by said flared cable guide surface.
3. A radius limiter according to any one of claims 1 and 2 wherein:
 - (a) said cover member includes a finger (96) defining at least one free edge (98);
 - (i) said free edge defining a portion of said flared guide surface.
4. A radius limiter according to claim 3 further including:
 - (a) a latch arrangement (106) releasably securing said finger to said frame piece.
5. A radius limiter according to claim 4 wherein:
 - (a) said trough section is defined by a vertically oriented wall (80) and a base (82);

- (i) said base bridging said vertically oriented wall (80) and said curved wall (76); and
 - (b) said finger includes a second free edge (99) selectively engaging said vertically oriented wall of said trough section;
 - (i) said latch arrangement being mounted on said vertically oriented wall and said second free edge to releasably secure said finger to said frame piece.

- 6. A radius limiter according to any one of claims 3-5 wherein:
 - (a) said finger includes an attachment portion (104) pivotally securing said finger to said frame piece.

- 7. A radius limiter according to claim 6 wherein:
 - (a) said attachment portion comprises a pair of tabs (116) projecting from said finger.

- 8. A method of limiting a radius of optical fiber cables; the method comprising providing a radius limiter (72) including a frame piece (74) including a vertically oriented curved wall (76); and a trough section (78) adjacent to the curved wall; the method characterized by:
 - (a) the step of providing a radius limiter includes providing a frame piece having a cover member (84) oriented at least partially over the trough section (78);
 - (i) the cover member defining at least a portion of a perimeter (88) of a cable entry aperture (86);
 - (ii) the portion of the perimeter of the cable entry aperture defined by the cover having a flared cable guide surface (90);
 - (b) directing optical fiber cables through the cable entry aperture (86) and against the flared cable guide surface (90) of the cover member; and
 - (c) after said step of directing, orienting the optical fiber cables within the trough section and against the curved wall.

9. A method according to claim 8 further including:
 - (a) before said step of directing, pivoting the cover member (84) relative to the frame piece (74) by releasing a latch connection (106) between the cover member and the frame piece.

10. A method according to claim 9 wherein:
 - (a) said step of pivoting includes rotating the cover member about a hinge point (118) between the cover member and the frame piece.

11. An optical fiber cable management system (30) comprising: a first drawer assembly (32) including a first chassis (34) and a first drawer (36) slidably mounted within said first chassis; said first chassis and first drawer defining a first storage interior (48); said first drawer assembly defining a first cable access entry to permit optical fiber cable to enter into said first storage interior; a second drawer assembly (32) including a second chassis (34) and a second drawer (36) slidably mounted within said second chassis; said second chassis and second drawer defining a second storage interior (48); said second drawer assembly defining a second cable access entry to permit optical fiber cable to enter into said second storage interior; and a mounting bracket connecting together at least said first drawer assembly and said second drawer assembly; the optical fiber cable management system characterized by:
 - (a) the mounting bracket connecting together at least said first drawer assembly and said second drawer assembly through an interlock arrangement (52);
 - (i) said interlock arrangement including:
 - (A) a plurality of non-threaded stud members (54) in one of: (i) said mounting bracket; and (ii) said first and second chassis; and
 - (B) a plurality of holes (56) sized for receiving said non-threaded stud members; said plurality of holes being defined by one of (i) said mounting bracket; and (ii) said first and second chassis.

12. An optical fiber cable management system according to claim 11 wherein:
 - (a) said interlock arrangement includes:
 - (i) at least two of said non-threaded stud members projecting from said first chassis;
 - (ii) at least two of said non-threaded stud members projecting from said second chassis; and
 - (iii) at least four of said holes defined by said mounting bracket receiving each of the non-threaded stud members of said first chassis and said second chassis.

13. A method of connecting a first drawer assembly to a second drawer assembly in an optical fiber cable management system; the method comprising providing a first and second drawer assembly (32); the first drawer assembly including a first drawer (36) slidably received by a first chassis (34); the second drawer assembly including a second drawer (36) slidably received by a second chassis (34); and securing a bracket to the first chassis and the second chassis; the method characterized in that:
 - (a) the step of securing a bracket to the first chassis and the second chassis includes inserting a non-threaded stud arrangement (54) into an aperture arrangement (56).

14. A method according to claim 13 wherein:
 - (a) said step of securing includes inserting a plurality of non-threaded studs (54) projecting from each of the first chassis and the second chassis into a plurality of holes (56) sized to receive the non-threaded studs defined by the bracket.

15. An optical fiber cable management panel (30) comprising: a drawer assembly (32) including a chassis (34) and a drawer (36); said drawer being slidably mounted within said chassis; said drawer assembly defining a storage interior (48) and a first cable access entry to permit optical fiber cable to enter into said storage interior; a cable radius limiter (72) slidably

mounted relative to said drawer assembly; and a control mechanism (125) secured to said drawer assembly to synchronize slidable movement of said cable radius limiter relative to slidable movement of said drawer within said chassis; said control mechanism including a rotating member (126) oriented to rotate between said drawer and said chassis; the optical fiber cable management panel characterized by:

- (a) said rotating member (126) has an axis of rotation (130) that is normal to said cable radius limiter.
16. An optical fiber cable management panel according to claim 15 wherein:
- (a) said control mechanism includes a bracket (134) and an axle (136);
 - (i) said rotating member being mounted for rotation on said axle.
17. An optical fiber cable management panel according to claim 16 wherein:
- (a) said rotating member includes a wheel (128).
18. An optical fiber cable management panel according to claim 17 wherein:
- (a) said bracket includes a projection arrangement (138) secured to said cable radius limiter.
19. An optical fiber cable management panel according to claim 18 wherein:
- (a) said drawer includes a base (42) defining an elongated slot (150);
 - (i) said bracket being secured to said cable radius limiter through said elongated slot.
20. An optical fiber cable management panel according to claim 19 wherein:
- (a) said drawer further includes a wheel guide (164) secured thereto having a guide surface (165) extending normal to said drawer base;
 - (b) said chassis includes a base (160) in a plane generally parallel to said drawer base; said chassis further includes a sidewall (162) extending normal to said chassis base;
 - (i) said wheel (128) oriented for rotation between and against said guide surface and said chassis sidewall.

21. An optical fiber cable management panel according to claim 20 wherein:
- (a) said bracket includes a catch (152);
 - (b) said chassis includes a stop member (158);
 - (i) said catch selectively engaging said stop member when said drawer and said radius limiter are slid relative to said chassis.
22. A method for use in an optical fiber cable management system having a drawer assembly (32); the drawer assembly including a drawer (36) slidably received by a chassis (34), a method for controlling slidable movement of a cable radius limiter (72) relative to slidable movement of the drawer within the chassis; the method comprising rotating a wheel (128), secured to the cable radius limiter, between the drawer and the chassis; the method characterized by:
- (i) the step of rotating a wheel includes rotating a wheel (128) having an axis of rotation (130) that is normal to the cable radius limiter.
23. A method according to claim 22 wherein:
- (a) the wheel is mounted on a bracket (134); the drawer includes a base (42) defining an elongated slot (150); the bracket is secured to the cable radius limiter through the elongated slot; the drawer further includes a wheel guide surface (165) extending normal to the drawer base; the chassis includes a base (160) in a plane generally parallel to the drawer base; the chassis further includes a sidewall (162) extending normal to the chassis base; and
 - (b) said step of rotating a wheel between the drawer and the chassis includes rotating the wheel between and against the guide surface and the chassis sidewall.

FIG.1

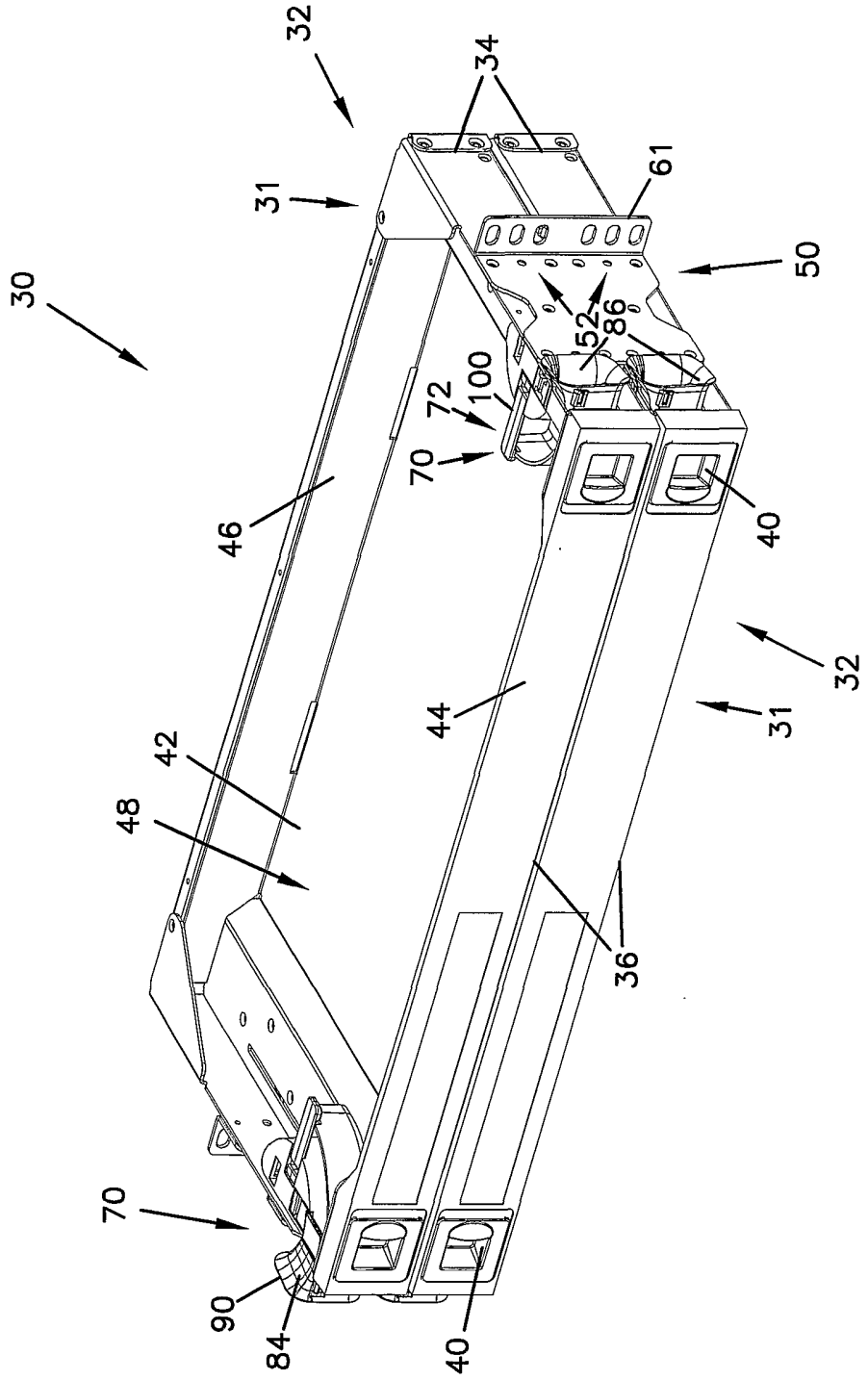

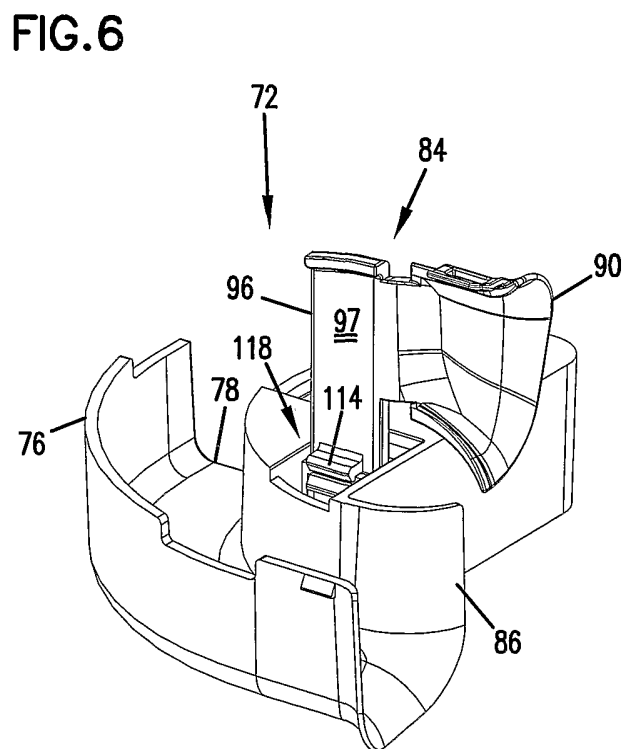
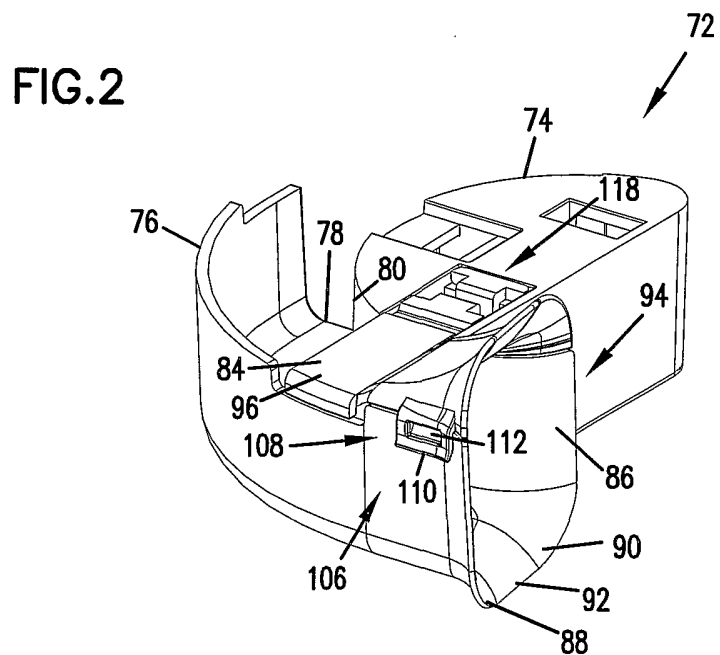

FIG.3

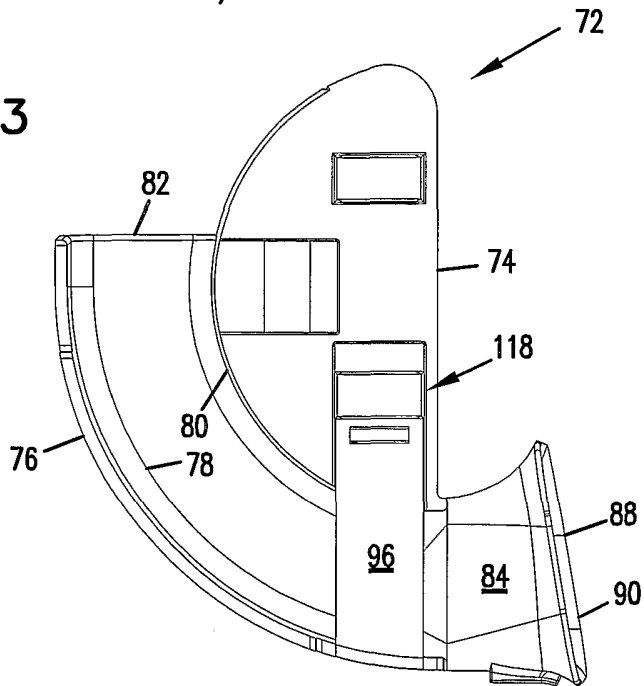

FIG.4

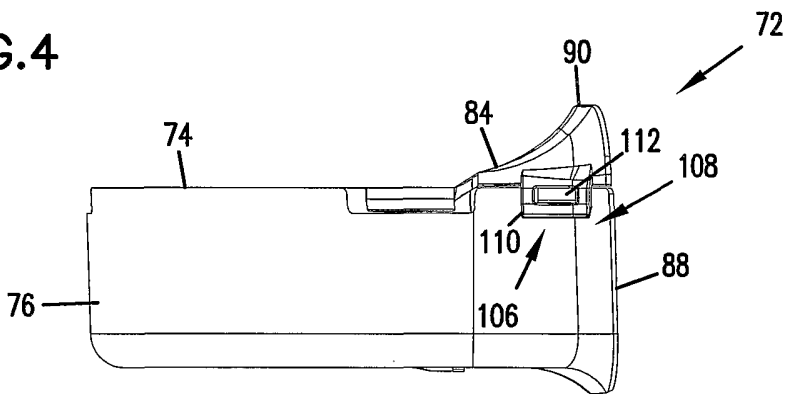

FIG.5

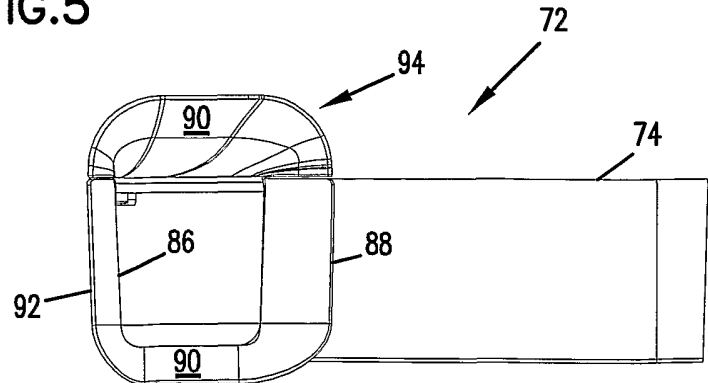

FIG.7

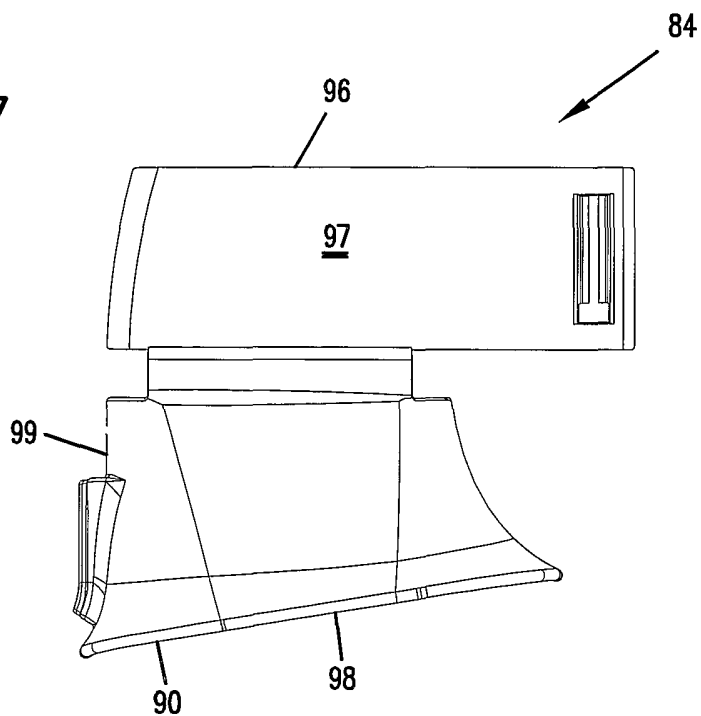

FIG.8

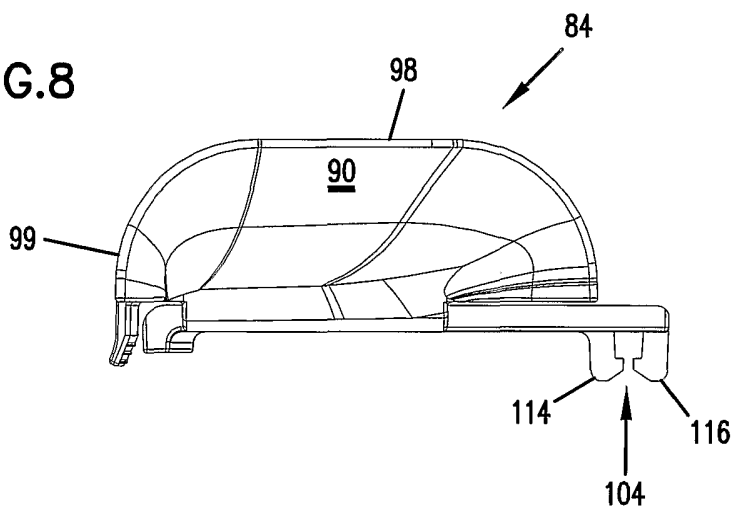
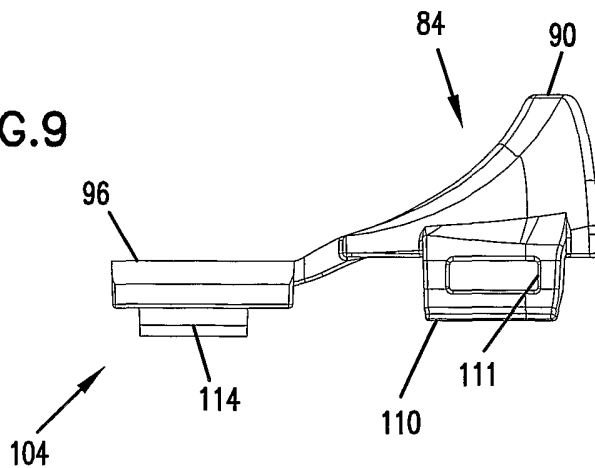

FIG.9



5/13

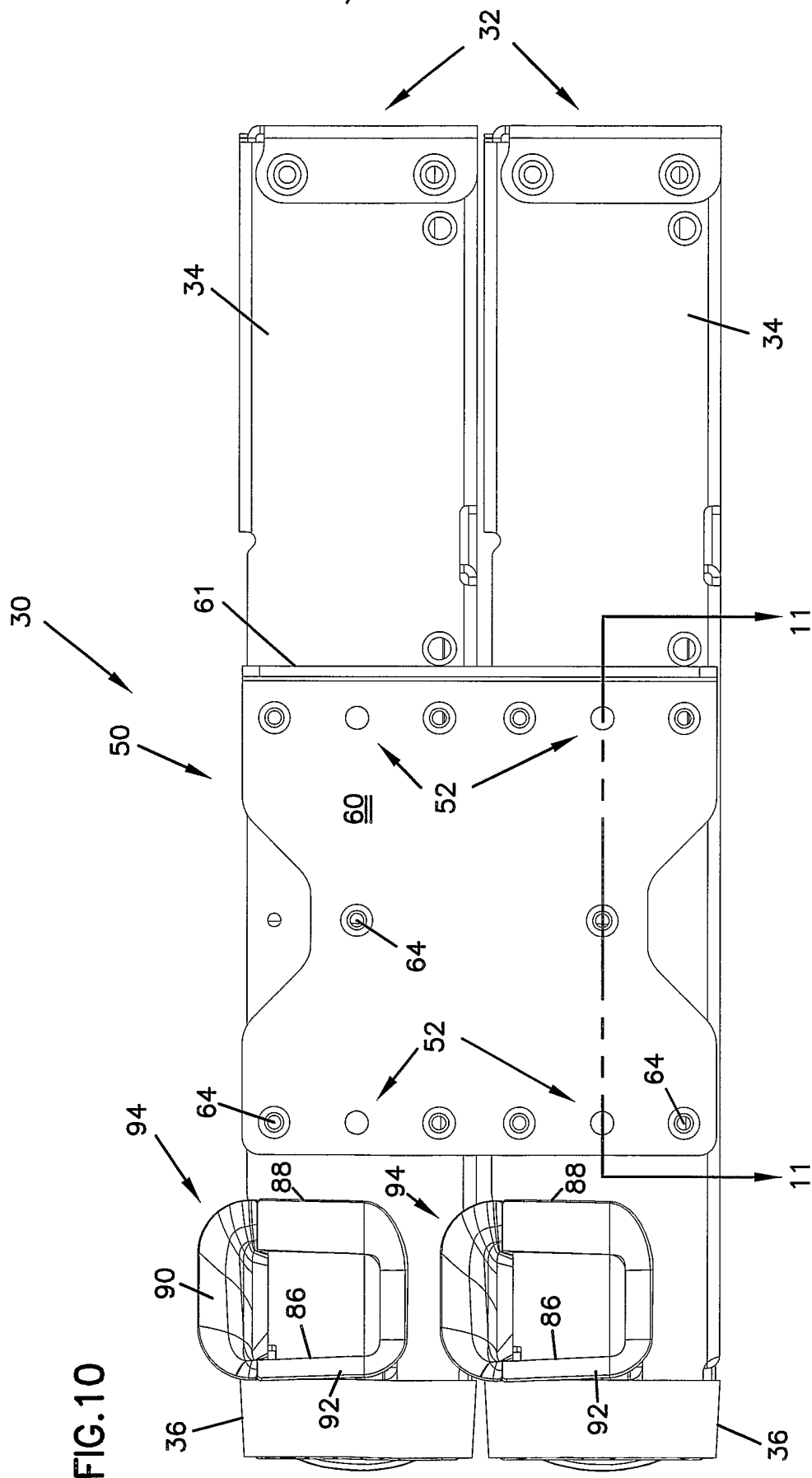

FIG.10

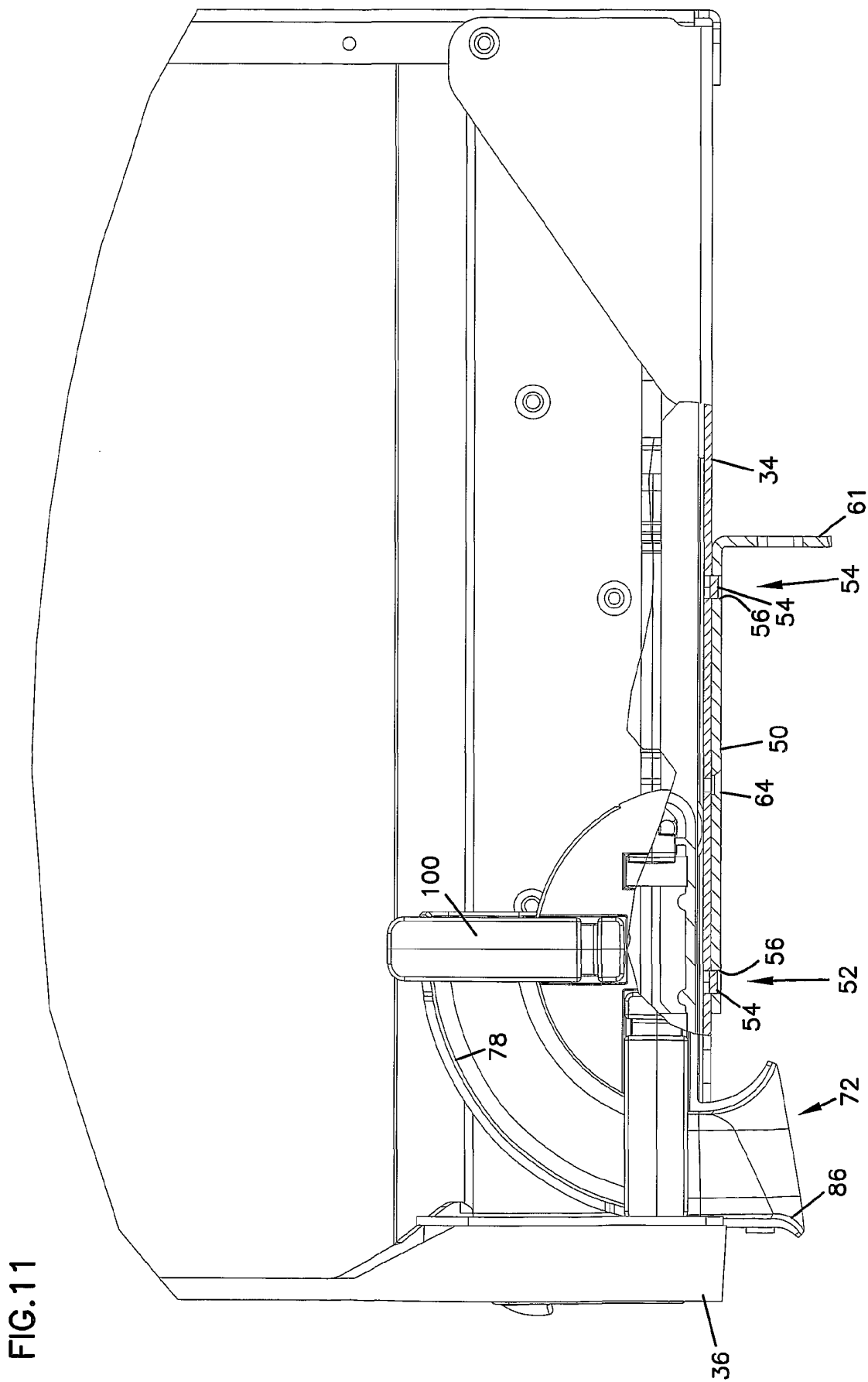

FIG. 11

7/13

FIG.12

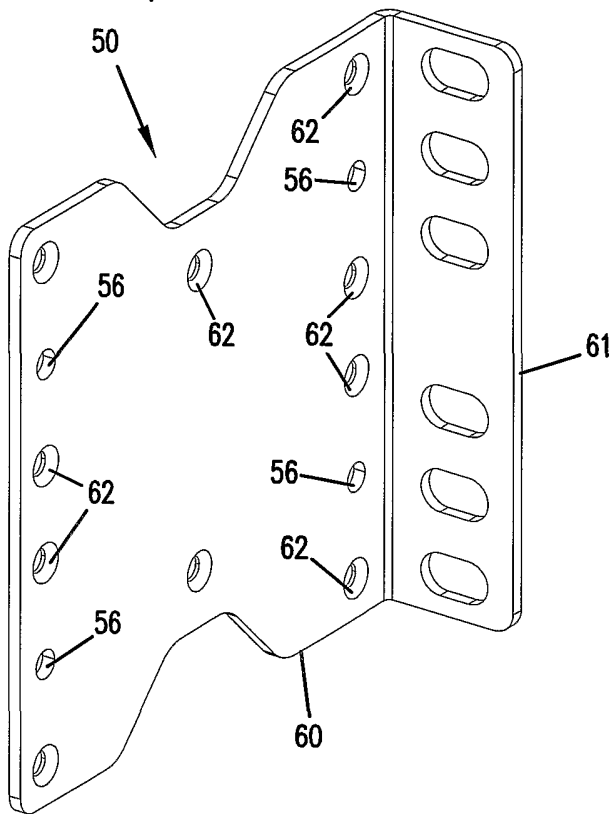

FIG.13

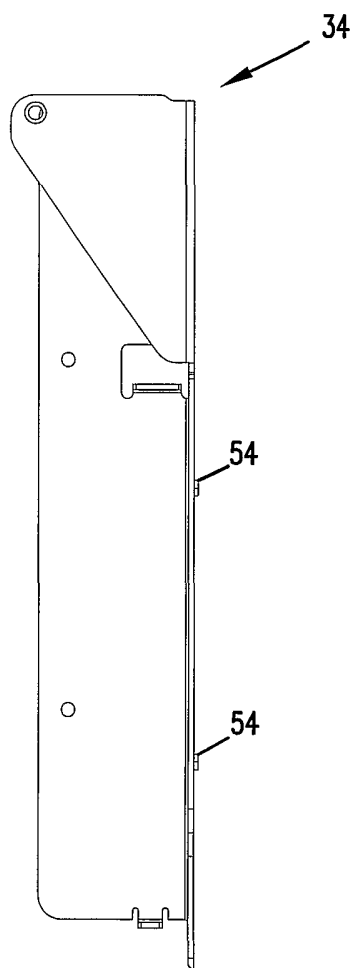
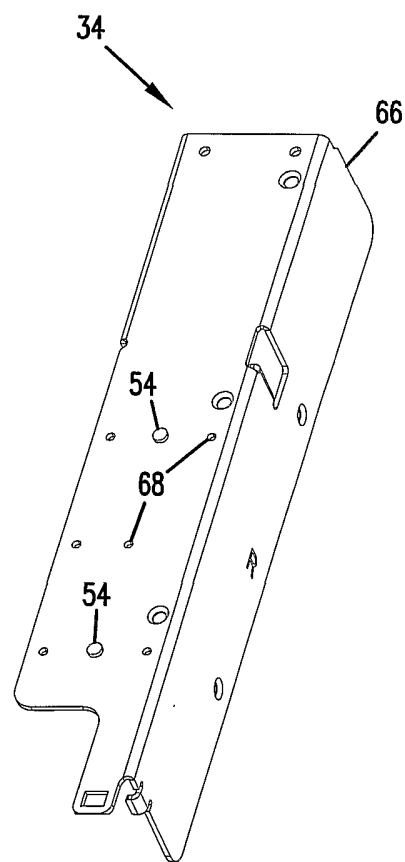

FIG.14



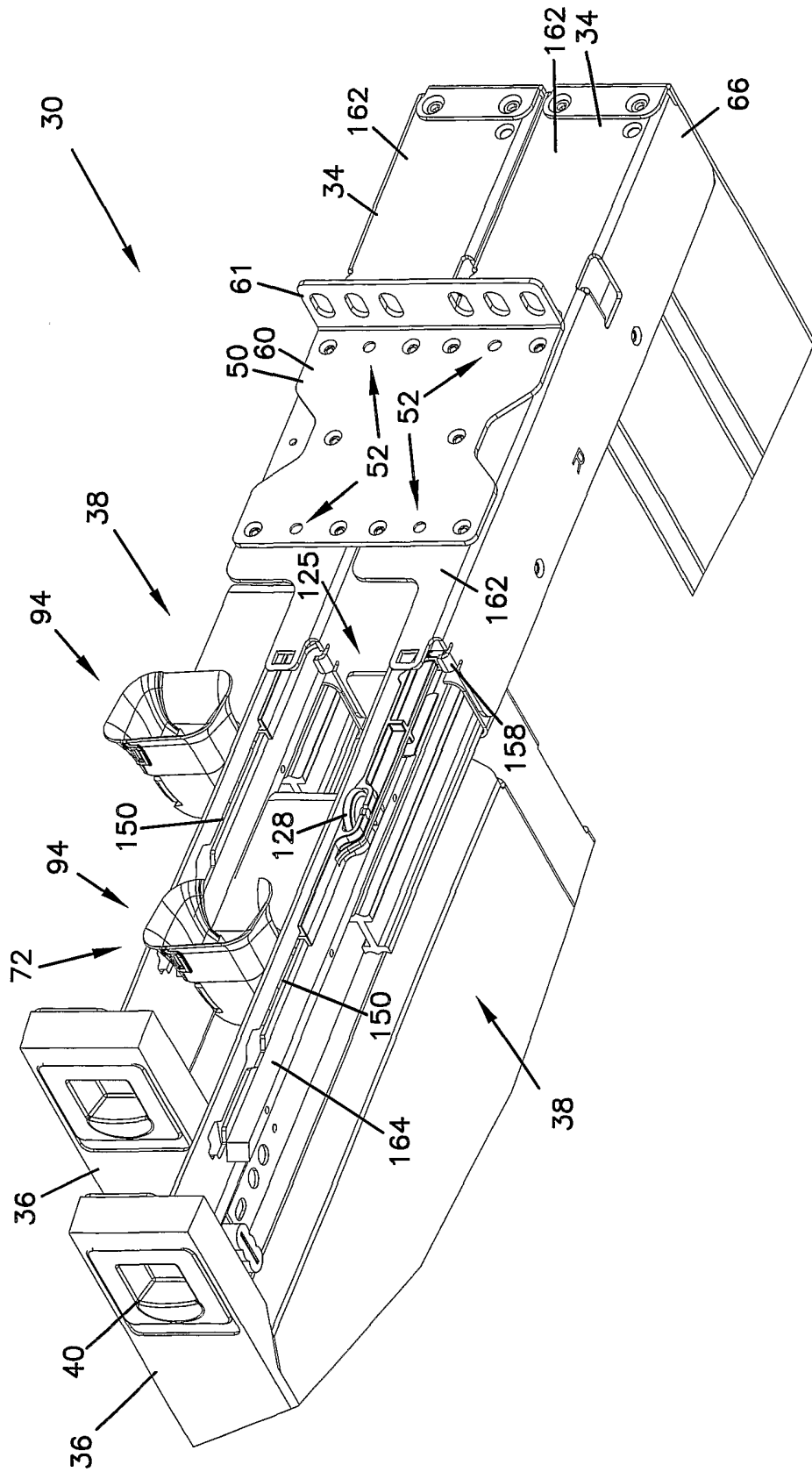

FIG.15

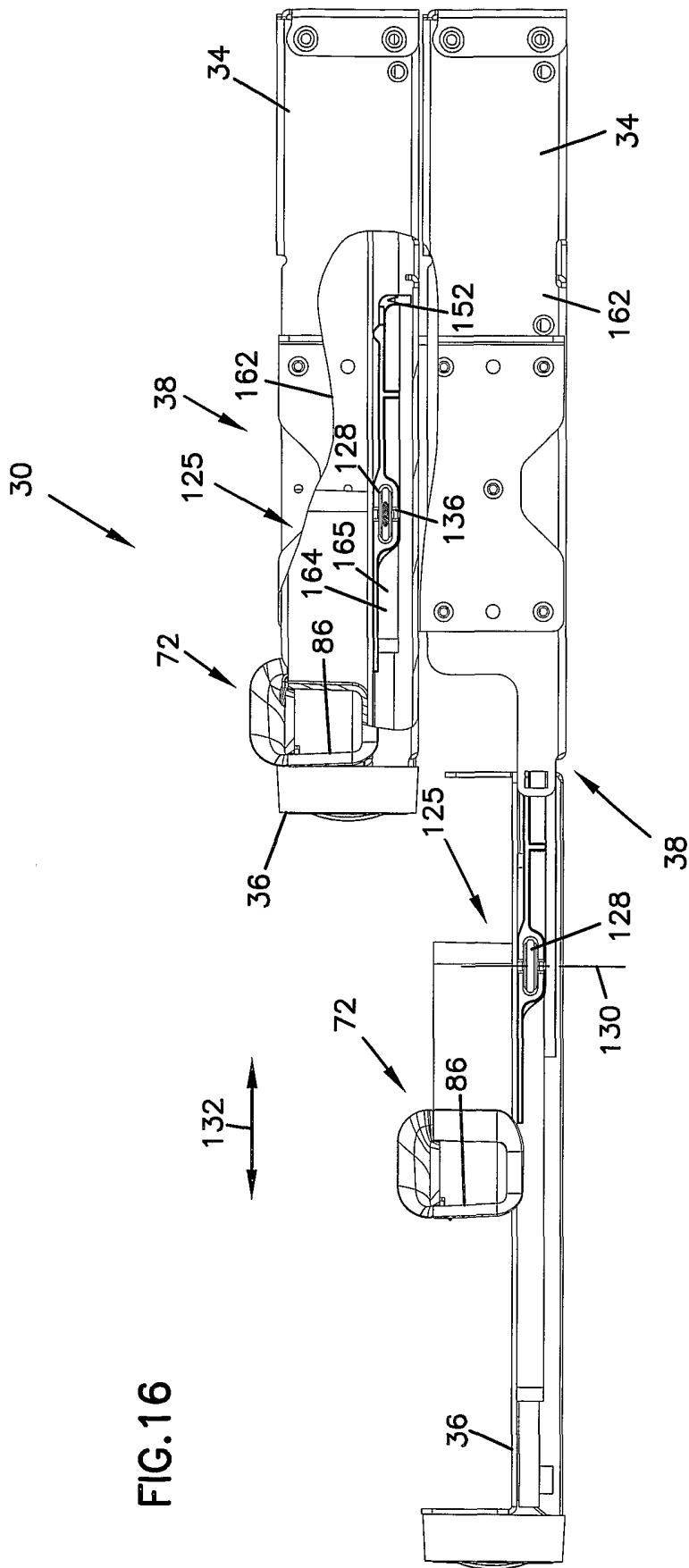

FIG. 16

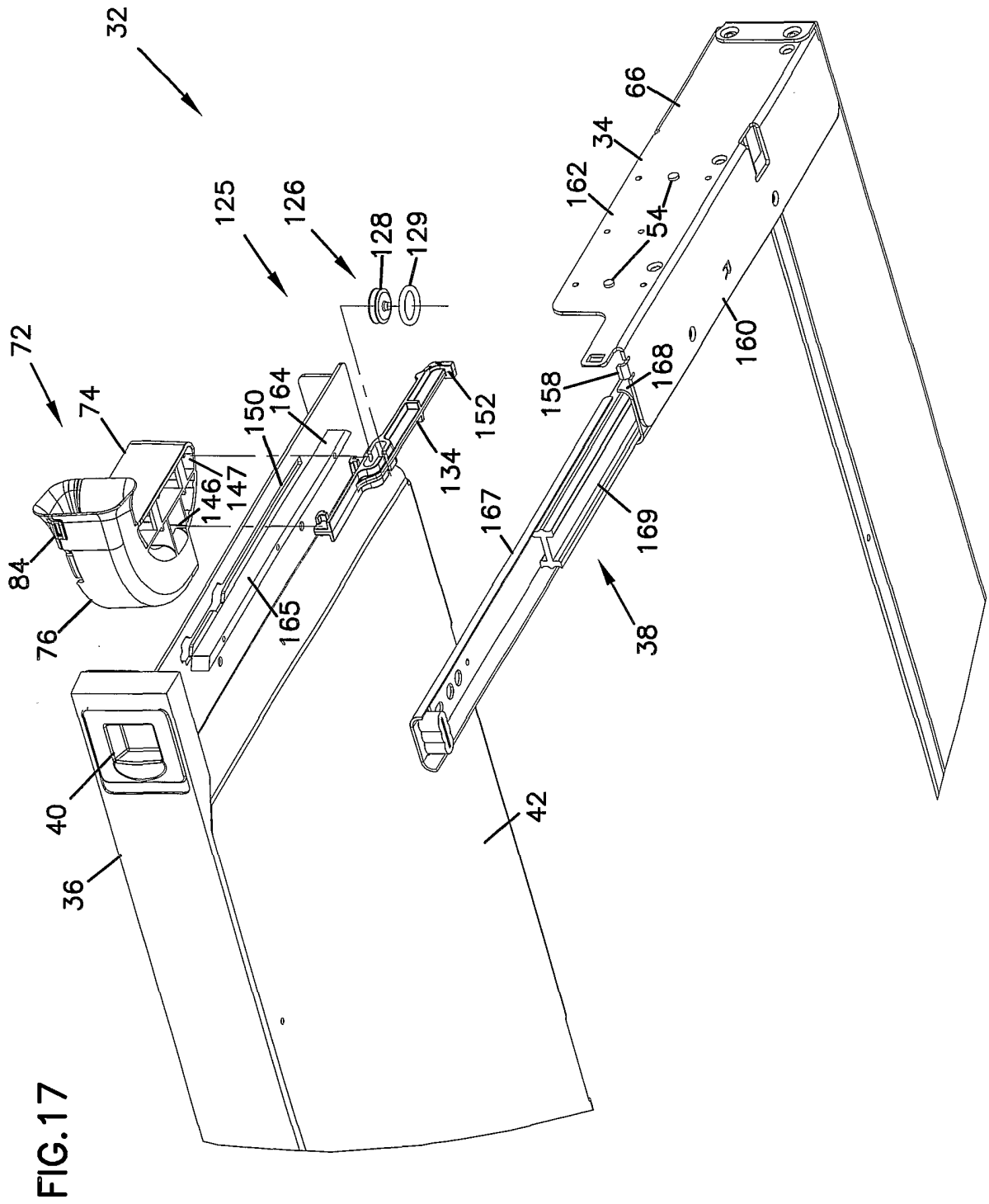

FIG.18

