

March 10, 1931.

C. DUMAT

1,795,388

ARRANGEMENT FOR SECURING THE LONGITUDINAL BINDING WIRES IN THE BOUND
RECIPIENTS USED FOR THE STORAGE AND TRANSPORTATION OF GAS
Filed Jan. 3, 1929

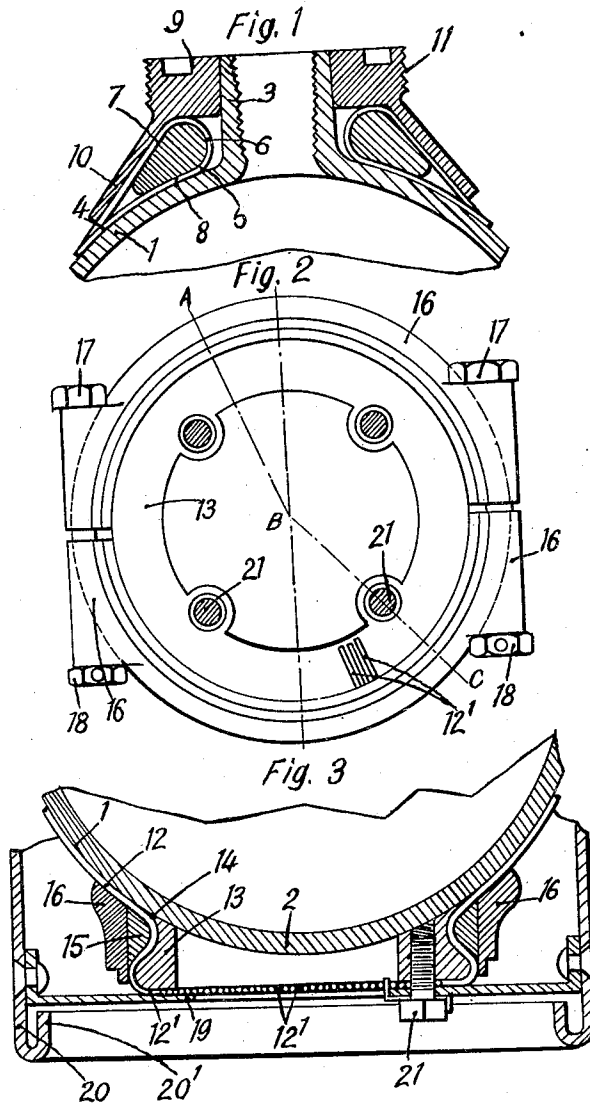

C. DUMAT
INVENTOR
By *Maxwell S. Cook*
attys.

UNITED STATES PATENT OFFICE

CLÉMENT DUMAT, OF PARIS, FRANCE, ASSIGNOR TO THE SOCIÉTÉ POUR L'EXPLOITATION DES TUBES ELECTRO-FRETTÉS, OF PARIS, FRANCE, A CORPORATION OF FRANCE

ARRANGEMENT FOR SECURING THE LONGITUDINAL BINDING WIRES IN THE BOUND RECIPIENTS USED FOR THE STORAGE AND TRANSPORTATION OF GAS

Application filed January 3, 1929, Serial No. 330,083, and in France January 9, 1928.

The present invention relates to the wire-bound recipients adapted for the storage and transportation of gas, and chiefly to vessels of this class consisting of a light expanding envelope, optionally corrugated, which is surrounded by longitudinal binding wires which are completed (or not) by transverse binding wires.

The invention further relates to a particular arrangement for securing the longitudinal binding wires upon such recipients or vessels, which latter have the form of a bottle, and are provided with a square base consisting of pressed sheet metal, by which the said bottles filled with gas are prevented from rolling when transported and the bottles will also stand in the vertical position.

In the securing arrangement according to the invention, the said binding wires, or piano wires, start from the bottom of the bottle, and are then wound at the top about a ring surrounding the neck of the bottle, returning thence to the bottom of the bottle adjacent their starting point.

The upper ring is held in position by a cap which is fitted by friction upon the bottle neck, and whose tapered lower part, flaring outwardly, fits exactly upon the wires at the outer periphery of the ring.

At the bottom of the bottle, the two strands of wire, placed side by side, are pressed against an annular male piece fitting upon the bottom of the bottle and a two-part female piece cooperating with the male piece and held by a collar provided with bolts and nuts. The two strands are then bent down upon the central part of the base of the bottle which is secured to the male piece by threaded bolts.

The accompanying drawings show by way of example an embodiment of the invention, in which:

Fig. 1 is an axial section of the upper part of the vessel, with the wires placed in position.

Fig. 2 is a bottom plan view of the vessel with the supporting foot removed.

Fig. 3 shows the lower part of the said vessel, in section on the line A—B—C of Figure 2.

Referring to Figures 1 and 2, 1 is the main body of the vessel or gas bottle, 2 the bottom part, and 3 the neck. The longitudinal binding wires 4 which are preliminarily cut (within a few centimeters) to their total length, are bent at the top around a ring 5 which is mounted on the bottle neck 3 and is rounded at its inner end 6, having at the outer end a tapered outline 7, which is downwardly directed. Its lower face 8 fits upon the bottle. The loops of the wire are held by a cap 9 which is fitted by tight friction upon the neck 3 and comprises a tapered flange 10 corresponding to the outline 7 of the ring 8. The said cap carries an external thread at 11 cooperating with the bottle cap.

At the lower part of the bottle, the two ends 12 of said wire which are placed side by side, are engaged between a ring-shaped male piece 13 in contact with the bottom of the bottle and grooved externally at 14, and a two-part female piece 15 coinciding with the groove 14 in the said male piece, it being held against the latter by a pressing collar 16 made in two pieces which are held together by the bolts 17 and the pinned nuts 8. The ends 12' of the wires 4 are then bent down against the lower face of the male piece 13, and are maintained by the central disk 19 of the base 20 which is secured to said male piece by the threaded bolts 21.

The base 20 consists of a cylindrical member whose lower part is enlarged so as to offer a square shape, and it has a U-shaped internal flange 20'.

The very simple arrangement herein described will afford great safety, while at the same time the weight of the vessel is not unduly increased. The wires 4 are disposed along the vessel or bottle, and are then formed at the ends, each in turn, for the wires must not be formed in advance, if the maximum resistance is to be obtained.

The present description is given solely as an indication, and is not of a limitative nature. For instance, the collar 16 may be eliminated in certain cases, and I may directly assemble the two halves of the female piece 15.

I may also add to the lower part of the

neck a small spacing ring 3 for the centering of the ring 5, this being necessary in order that all the wires shall operate in the same manner.

5 If any defect in the solidity of the cap 9 is feared, I may press it strongly upon the bottle and hold it in place by interposing between said cap and the valve of the bottle, a suitable concave spring washer which prevents the
10 cap from rising.

Claims:

1. A device for the attaching of the longitudinal binding wires in bound recipients adapted for the storage and transportation of
15 gases and in which the binding wires have a sufficient tension to assure a complete resistance of the walls against an internal pressure, characterized by the fact that the binding wires form a loop around a ring placed
20 on the neck of the vessel and are held at the two ends, at the lower part of the vessel.

2. A device, as claimed in claim 1, in which the ring, about which the wire is placed, has a rounded inner profile, a lower face fitting on
25 the shape of the bottle, and an outer tapered profile extending downwardly and is held by a cap which is fitted by force on the neck of the vessel and is provided with a tapered flange adapted to fit upon the exterior of the
30 ring.

3. A device for the attaching of the longitudinal binding wires in bound recipients adapted for the storage and transportation of
35 gases, characterized by the fact that the binding wires form a loop around a ring placed on the neck of the vessel and that, at the lower part of the vessel, the two strands of wire placed side by side are pressed between a male piece in the form of a ring in
40 contact with the bottle and provided with an external circular groove and a female piece in two parts adapted to fit into this groove, the same being held by a collar provided with bolts and nuts.

4. A device, as claimed in claim 3, in which the ends of the strands are bent down on the inner face of the male piece and are pressed
45 by the central part of the base of the vessel, which part is secured to the male piece by means of threaded bolts.
50

In testimony whereof he has signed this specification.

CLÉMENT DUMAT.

55

60

65