

(19) World Intellectual Property Organization
International Bureau



(43) International Publication Date
12 June 2008 (12.06.2008)

PCT

(10) International Publication Number
WO 2008/070545 A1

- (51) International Patent Classification:
B24B 55/10 (2006.01)
- (21) International Application Number:
PCT/US2007/086041
- (22) International Filing Date:
30 November 2007 (30.11.2007)
- (25) Filing Language: English
- (26) Publication Language: English
- (30) Priority Data:
11/565,987 1 December 2006 (01.12.2006) US
- (71) Applicant (for all designated States except US): **3M INNOVATIVE PROPERTIES COMPANY** [US/US];
3M Center, Post Office Box 33427, Saint Paul, Minnesota 55133-3427 (US).
- (72) Inventor: **MINICK, Chris A.**; 3M Center, Post Office Box 33427, Saint Paul, Minnesota 55133-3427 (US).
- (74) Agents: **PATCHETT, David B.**, et al.; 3M Center, Office of Intellectual Property Counsel, Post Office Box 33427, Saint Paul, Minnesota 55133-3427 (US).
- (81) Designated States (unless otherwise indicated, for every kind of national protection available): AE, AG, AL, AM, AT, AU, AZ, BA, BB, BG, BH, BR, BW, BY, BZ, CA, CH,

CN, CO, CR, CU, CZ, DE, DK, DM, DO, DZ, EC, EE, EG, ES, FI, GB, GD, GE, GH, GM, GT, HN, HR, HU, ID, IL, IN, IS, JP, KE, KG, KM, KN, KP, KR, KZ, LA, LC, LK, LR, LS, LT, LU, LY, MA, MD, ME, MG, MK, MN, MW, MX, MY, MZ, NA, NG, NI, NO, NZ, OM, PG, PH, PL, PT, RO, RS, RU, SC, SD, SE, SG, SK, SL, SM, SV, SY, TJ, TM, TN, TR, TT, TZ, UA, UG, US, UZ, VC, VN, ZA, ZM, ZW.

(84) Designated States (unless otherwise indicated, for every kind of regional protection available): ARIPO (BW, GH, GM, KE, LS, MW, MZ, NA, SD, SL, SZ, TZ, UG, ZM, ZW), Eurasian (AM, AZ, BY, KG, KZ, MD, RU, TJ, TM), European (AT, BE, BG, CH, CY, CZ, DE, DK, EE, ES, FI, FR, GB, GR, HU, IE, IS, IT, LT, LU, LV, MC, MT, NL, PL, PT, RO, SE, SI, SK, TR), OAPI (BF, BJ, CF, CG, CI, CM, GA, GN, GQ, GW, ML, MR, NE, SN, TD, TG).

Declarations under Rule 4.17:

- as to applicant's entitlement to apply for and be granted a patent (Rule 4.17(ii))
- as to the applicant's entitlement to claim the priority of the earlier application (Rule 4.17(iii))

Published:

- with international search report
- before the expiration of the time limit for amending the claims and to be republished in the event of receipt of amendments

(54) Title: **SANDING TOOL AND DUST COLLECTION SYSTEM THEREFOR**

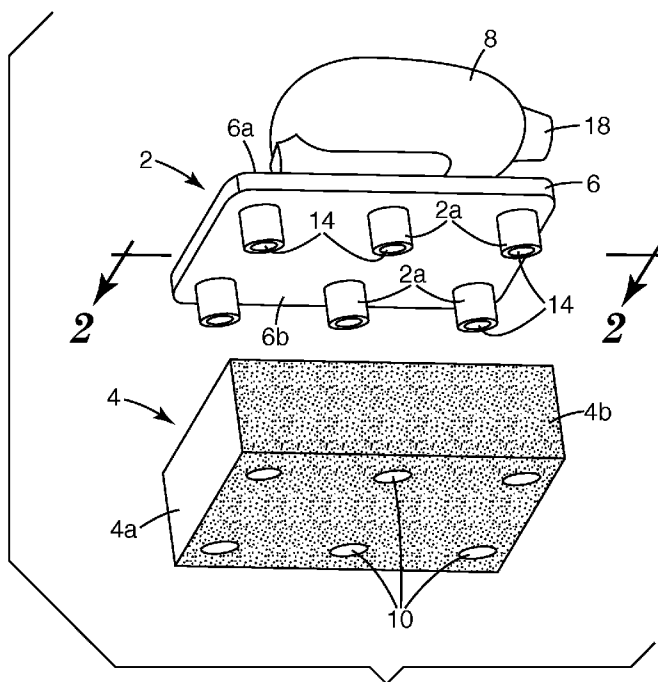

(57) Abstract: A hand-held manually-operated sanding tool includes a base having a lower surface including a plurality of attachment posts extending outwardly therefrom and a handle opposite the base lower surface for a user to grasp and maneuver the tool.

WO 2008/070545 A1

SANDING TOOL AND DUST COLLECTION SYSTEM THEREFOR

Background

5 The present invention relates generally to sanding tools and, more particularly, to hand-held, manually-operated sanding tools for use with resilient abrasive articles such as sanding sponges.

 Sanding sponges are commonly used to hand sand or finish a work surface, such as drywall or wood. Sanding sponges are commercially available from 3M Company, St.
10 Paul, Minnesota under the trade designation 3M Sandblaster sanding sponge. Sanding sponges are also known in the patented prior art. U.S. Patent No. 6,059,850 (Lise et al.), for example, discloses a resilient abrasive article including a resilient elongatable substrate, abrasive particles adhesively bonded to the substrate with a flexible make coat, and a hard size coat applied over the abrasive particles and the flexible make coat.

15 In hand sanding, the user holds the sanding sponge directly in his or her hand to move the sanding sponge across the work surface. Sanding by hand can, or course, be an arduous task. To facilitate the hand sanding process, the sanding sponge may be placed in a holder. Holders can be readily grasped by a user to make hand sanding faster and easier. Holders for sanding sponges are known in the patented prior art. U.S. Patent No.
20 6,379,237 (Gordon), for example, discloses a holder for releasably retaining an abrasive sponge. The holder comprises a base for holding the sponge therein, the base having a top surface and surfaces depending downwardly from the top surface to border the sponge partially along at least three of its sides, and a handle releasably connected to the top surface of the base.

25 To collect dust generated during sanding, sanding tools have been developed that can be connected with a vacuum device. U.S. Patent Publication No. 2006/0199484 (Brown), for example, discloses a resilient sanding block of the type comprising a core having a plurality of exterior surfaces, including a first major surface and a second major surface and side surfaces, and having a layer of abrasive material disposed thereon. The
30 resilient sanding block may have one or more apertures or through holes extending from

one major surface to the other major surface and channels formed in at least one of the major surfaces, with the channels in communication with the aperture. When a vacuum source is operatively connected to the aperture, the dust created by sanding will be substantially removed into the vacuum source via the channels and the aperture. A holder for a resilient sanding block is also disclosed, as well as a handle for the holder, which together form a sanding system.

Known sanding tools suffer from one or more drawbacks or shortcomings. For example, known sanding tools may be heavy, difficult or cumbersome to use, may be expensive or difficult to manufacture, or may lack durability; the holder may interfere with the use of the abrasive article and prevent the abrasive article from sanding adjacent an edge, may not securely hold the sanding sponge, or can only be used with a sanding sponge having a certain defined size and shape; and/or the vacuum collection system may clog quickly, may create an objectionable amount of noise, or may not collect the desired quantity of dust generated during the sanding operation.

It would be desirable to provide a sanding tool that is lightweight, easy to make and use, durable, quiet, does not clog quickly, can be used with sanding sponges having a variety of shapes and sizes, and allows the abrasive article to be sand adjacent an edge.

Summary

The present invention provides a hand-held, manually-operated sanding tool comprising a base having a lower surface including a plurality of attachment posts extending outwardly therefrom, and a handle opposite the base lower surface for a user to grasp and maneuver the tool.

In one embodiment, the sanding tool includes an abrasive article removably secured to the base adjacent the lower surface. In one aspect, the abrasive article contains openings sized to receive and matingly engage the attachment posts, thereby connecting the abrasive article with the tool. In another aspect, the openings are through-bores that extend from one major surface of the abrasive article to the opposite major surface. In other aspects, the abrasive article may be a resilient abrasive article, the abrasive article may be a rectangular prism having at least four abrasive side surfaces, the abrasive article

may comprise a foam substrate with abrasive particles adhered to the substrate, and the abrasive article may have a thickness greater than the length of the attachment posts.

In various specific embodiments, the attachments posts may be rigid hollow cylinders having a diameter of greater than about 1/8 of an inch and a length of greater than about 1/8 of an inch, the lower surface of the tool may include between 4 and 10 attachment posts, the attachment posts may be arranged in a pair of rows, and the entire peripheral edge of the base may be contained within the peripheral edge of the abrasive article.

In another embodiment, the tool may contain a dust collecting network for gathering, containing and transporting dust and debris from the abraded surface to a remote collection device. The base may contain a manifold, and the attachment posts contain dust collecting inlet ports in fluid communication with the manifold.

In addition, the handle may include a conduit in fluid communication with the manifold, and the handle may include an outlet port at the end of the conduit opposite the manifold for connection with a vacuum source, thereby to draw dust from the abraded work surface through the inlet ports, through the attachment posts, into the manifold, through the conduit, through the outlet port, and into a remote collection device. In another aspect, the sanding tool may include an extension pole connected with the handle.

In another aspect, the present invention provides a sanding system comprising hand-held, manually-operated sanding tool including a base having a lower surface including a plurality of attachment posts extending outwardly therefrom and a handle opposite the base lower surface for a user to grasp and maneuver the tool, a cyclone separation device connected with the sanding tool, and a vacuum source connected with the cyclone separation device. The cyclone separation device may include a top including inlet and outlet ports, and a bottom having a collection chamber for collecting dust and debris separated from the contaminated fluid stream entering the cyclone separation device. In another aspect, the cyclone separation device is connected with the sanding tool with a flexible hose having a smooth inner surface.

Advantages of certain embodiments include the ability to finish a surface in the region immediately adjacent an edge, that the tool can be lightweight, easy to make and

use, durable, quiet, and does not clog quickly, and that sanding sponges having a variety of shapes and sizes can be used with the tool.

Brief Description of the Drawings

5 The present invention will be further described with reference to the accompanying drawings, in which:

Fig. 1 is an exploded perspective view of a sanding tool according to the invention;

Fig. 2 is cross-sectional side view taken along 2-2 of Fig. 1;

10 Fig. 3 is a diagrammatic illustration of a cyclone separation device that can form part of a dust collecting sanding system.

Detailed Description

Referring now to the drawings, wherein like reference numerals refer to like or corresponding parts throughout the several views, FIGS. 1 and 2, show a hand-held, manually-operated sanding tool 2, and a resilient abrasive article in the form of a sanding sponge 4 removably attached to the sanding tool 2. The term “manually-operated” refers to the fact that the tool 2 is not a power tool. That is, all of the power needed to operate the tool 2 is provided by a user (not shown), and the tool 2 itself does not include a motor. It will be recognized, however, that principles of the present invention may be applied to a power tool and are not necessarily limited to manually-operated sanding tools.

15

20

The sanding tool 2 generally includes a base 6 having opposed upper 6a and lower 6b surfaces, and a handle 8 extending from the upper surface 6a that can be grasped by a user, and thereby allow the user to move and maneuver the sanding tool 2 to perform manual sanding. In the illustrated embodiment, the base 6 is generally rectangular, and the lower surface 6b of the base 6 includes a generally planar interior surface region. In accordance with a characterizing aspect of the sanding tool 2, a plurality of attachment posts 2a extend outwardly from the lower surface 6b of the base 6 opposite the handle 8. As described more fully below, the attachment posts 2a serve to removably secure the sanding sponge 4 to the sanding tool 2 adjacent the lower surface 6b of the base 6.

25

30 The length of the attachment posts 2a is less than the thickness of the sanding sponge 4. In this manner, when the sanding sponge 4 is placed on the sanding tool 2, the

attachment posts 2a are contained within and concealed by the sanding sponge 4. That is, no portion of the attachment posts 2a extend through the sanding sponge 4. In the illustrated embodiment, the attachment posts 2a are rigid hollow cylinders. The attachment posts 2a typically have a diameter of greater than about 1/8 inch and a length of greater than about 1/8 inch. Attachment posts 2a having other shapes and sizes are within the scope of the invention. The attachment posts 2a are typically hollow to allow for the collection of dust as described below, but they may also be solid.

To prevent the sanding sponge 4 from rotating when it is secured to the sanding tool 2, the sanding tool is provided with at least two attachment posts 2a. That is, by providing the sanding tool 2 with at least two attachment posts 2a, the sanding sponge 4 cannot rotate relative to the sanding tool 2 without damaging either the sponge 4 or the tool 2. In addition, to provide a more secure attachment, the attachment posts 2a are typically evenly spaced or evenly distributed on the lower surface 6b of the base 6. The number, size and arrangement of attachment posts 2a is not significant to the invention hereof, so long as it provides a sufficiently secure connection between the sanding tool 2 and the sanding sponge 4. The sanding tool typically includes between four and ten attachment posts 2a.

The sanding sponge 4 contains a plurality of openings 10 arranged and sized to receive and matingly engage the attachment posts 2a, thereby to form a compression or friction fit attachment with the sanding tool 2. In the illustrated embodiment, the base includes six attachment posts 2a arranged in a pair of rows, and the sanding sponge 4 contains six corresponding openings 10 that form the compression or friction fit around each of the associated attachments posts 2a. In this manner, a user can readily remove the sanding sponge 4 from the sanding tool 2 and either clean the sanding sponge 4 or replace it with a new sanding sponge.

In the illustrated embodiment, the openings 10 are through-bores that extend from one major surface of the sanding sponge 4 to the opposite major surface, thereby allowing dust and debris to be drawn into the openings 10 and through the sanding sponge 4. If the sanding tool 2 is to be used as a holder only - and not as part of a dust collecting system - the openings 10 need not extend through the sanding sponge 4. That is, the openings 10 may be cavities or holes that extend only partially into the sanding sponge 4. The sanding

sponge 4 generally includes a foam substrate 4a with abrasive particles 4b adhered to the substrate 4a. In the illustrated embodiment, the sanding sponge 4 has the shape of a rectangular prism. Abrasive particles are provided on the top, bottom and side surfaces of the sanding sponge 4, and the end surfaces of the sanding sponge 4 are generally free of
5 abrasive particles. Any sanding sponge having at least one abrasive surface is contemplated in connection with the present invention.

One advantage of forming the connection between the sanding tool 2 and the sanding sponge 4 using attachment posts 2a - rather than a shroud-type of holder - is that the friction fit connection is formed entirely within the interior body of the sanding sponge
10 4. That is, the sanding sponge 4 is arranged over the attachment posts 2a, thereby removably connecting the sanding sponge 4 with the sanding tool 2. In this manner, the sanding tool 2 may be designed so that the entire peripheral edge of the base 6 is contained within the peripheral edge of the sanding sponge 4. In this manner, the entire perimeter of the sanding sponge 4 remains free and unencumbered such that the sanding tool 2 does not
15 interfere with the user's ability to sand a work surface immediately adjacent to an edge. The compression fit formed by the attachment posts 2a within the body of the sanding sponge 4 does not utilize the perimeter side surfaces of the sanding sponge 4, and by not utilizing the perimeter of the sanding sponge 4, the attachment posts 2a do not interfere with the sanding of a work surface that abuts another surface. Stated another way, by
20 providing an internal connection, the outer edge of sanding sponge 4 remains exposed so that the sanding sponge 4 can be maneuvered directly into contact with a wall surface adjacent the work surface being sanded.

In addition, by providing an internal connection interface rather than a connection interface that utilizes the perimeter of the sanding sponge, sanding sponges of different
25 sizes and shapes can be secured to the sanding tool, so long as the sanding sponges are provided with openings that otherwise match the size, shape and arrangement of the attachment posts 2a provided on the sanding tool 2.

In the illustrated embodiment, the sanding tool 2 contains a dust collection network for gathering, containing and transporting dust and debris from the abraded work surface
30 to a remote collection and storage device, described in greater detail below. The base 6 contains a manifold 12, and the attachment post 2a are hollow and contain dust collecting

inlet ports 14 that are in fluid communication with the manifold 12, and the handle 8 contains a conduit 16 that extends in fluid communication from the manifold 12 to an outlet port 18. The outlet port 18 may be connected with a vacuum source 20 (Fig. 3) via a hose 22 to draw dust and debris from the abraded work surface, through the inlet ports 14, through the attachment posts 2a, into the manifold 12, through the handle 8 via the conduit 16, through the outlet port 18, and into a remote collection and storage system. The remote collection and storage system may be the vacuum source 20 itself, which may be a conventional wet/dry-type shop vacuum, or it may further include a separator such as the cyclone separation device 24 described below.

Referring now to Fig. 3, there is shown a cyclone separation device 24 that can be connected between the sanding tool 2 and the vacuum source 20 to form a dust collection and storage system. One shortcoming of sanding tools with dust collecting capability is that the vacuum source tends to clog quickly. Conventional vacuum sources, for example, typically include a dead-end type filter that removes contaminants from the air stream by forcing the air through the filter. Because of the large quantity of dust generated during most sanding operations, such filters clog quickly. The cyclone separation device 24 overcomes this shortcoming by removing a large majority of the contaminants entrained in the air stream before it reaches the vacuum source, thereby significantly increasing the life of the filter in the vacuum source.

Other dust collection networks are contemplated in connection with the present invention. For example, rather than having the dust laden fluid stream travel through the handle 8 to the outlet port 18, the upper surface 6a of the base 6 may include an outlet port that may be connected with a vacuum source 20.

According to another characterizing aspect of the sanding system, the cyclone separation device 24 is connected with the sanding tool 2 and the vacuum source 20 with a flexible hose 22 having a smooth inner surface. The sound level generated by conventional hoses having corrugated inner surfaces tends to be objectionable when operated at flow rates typically needed to achieve a desirable level of dust collection. Hoses having smooth inner surfaces, it has been found, are much quieter when operated at the same flow rates. A suitable hose having a smooth inner surface is available from A-M Systems, Inc., Carlsborg, WA having a diameter of 15 mm.

The cyclone separation device 24 generally includes a top portion 24a having a side inlet port 26 and a top outlet port 28, and a bottom portion 24b having a collection chamber 30 for collecting dust and debris that has been removed from the contaminated air stream entering the cyclone separation device 24. To allow for easy cleaning, the collection chamber 30 is threadably connected with the top portion 24a. In one desirable embodiment of the invention, the top portion 24a of the cyclone separation device 24 had an upper diameter D_U of about 75 mm, a lower diameter D_L of about 35 mm, and a height H of about 140.

When operated at a volumetric flow rate of 75 cubic feet per minute (cfm), this cyclone separation device removed approximately 98% by weight of the contaminant in an incoming air stream produced by a 60 grit 3M Sandblaster sanding sponge while sanding a wooden surface. The cyclone separation device 24 is typically small and light enough to be portable (i.e. carried by the user), but it may also be combined with the vacuum source and used as a more stationary accessory.

Persons of ordinary skill in the art may appreciate that various changes and modifications may be made to the invention described above without deviating from the inventive concept. For example, the sanding tool 2 may be connected with an extension pole for sanding hard to reach areas. In addition, the sanding tool may comprise an interface pad removably secured to the lower surface of the base 6 via the attachment posts 2a, and a sheet-like abrasive may be removably secured to the interface pad. Thus, the scope of the present invention should not be limited to the structures described in this application, but only by the structures described by the language of the claims and the equivalents of those structures.

What is claimed is:

1. A hand-held, manually-operated sanding tool, comprising:
 - (a) a base having a lower surface including a plurality of attachment posts
5 extending outwardly therefrom; and
 - (b) a handle opposite the base lower surface for a user to grasp and maneuver
the tool.

2. A sanding tool as defined in claim 1, further comprising an abrasive article
10 removably secured to the base adjacent the lower surface.

3. A sanding tool as defined in claim 2, wherein the abrasive article contains
openings sized to receive and matingly engage the attachment posts, thereby connecting
the abrasive article with the tool.
15

4. A sanding tool as defined in claim 3, wherein the openings are through-bores
extending from one major surface of the abrasive article to the opposite major surface.

5. A sanding tool as defined in claim 4, wherein the abrasive article is a resilient
20 abrasive article.

6. A sanding tool as defined in claim 5, wherein the abrasive article is a rectangular
prism having at least four abrasive side surfaces.

- 25 7. A sanding tool as defined in claim 6, wherein the abrasive article comprises a foam
substrate with abrasive particles adhered to the substrate.

8. A sanding tool as defined in claim 7, wherein the abrasive article has a thickness
greater than the length of the attachment posts.
30

9. A sanding tool as defined in claim 8, wherein the attachments posts are rigid hollow cylinders having a diameter of greater than about 1/8 of an inch and a length of greater than about 1/8 of an inch.
- 5 10. A sanding tool as defined in claim 9, wherein the lower surface of the tool includes between 4 and 10 attachment posts.
11. A sanding tool as defined in claim 1, wherein the attachment posts are arranged in a pair of rows.
- 10 12. A sanding tool as defined in claim 1, wherein the entire peripheral edge of the base is contained within the peripheral edge of the abrasive article.
13. A sanding tool as defined in claim 1, wherein the tool contains a dust collecting network for gathering, containing and transporting dust and debris from the abraded surface to a remote collection device.
- 15 14. A sanding tool as defined in claim 1, wherein the base contains a manifold, and the attachment posts contain dust collecting inlet ports in fluid communication with the manifold.
- 20 15. A sanding tool as defined in claim 1, wherein the handle includes a conduit in fluid communication with the manifold, and further wherein the handle includes an outlet port at the end of the conduit opposite the manifold for connection with a vacuum source, thereby to draw dust from the abraded work surface through the inlet ports, through the attachment posts, into the manifold, through the conduit, through the outlet port, and into a remote collection device.
- 25 16. A sanding tool as defined in claim 1, further comprising an extension pole connected with the handle.
- 30

17. A sanding system, comprising:
- (a) hand-held, manually-operated sanding tool, comprising:
 - (i) a base having a lower surface including a plurality of attachment posts extending outwardly therefrom; and
 - 5 (ii) a handle opposite the base lower surface for a user to grasp and maneuver the tool;
 - (b) a cyclone separation device connected with the sanding tool; and
 - (c) a vacuum source connected with the cyclone separation device.
- 10 18. A sanding system as defined in claim 17, wherein the cyclone separation device include a top including inlet and outlet ports, and a bottom having a collection chamber for collecting dust and debris separated from the contaminated fluid stream entering the cyclone separation device.
- 15 19. A sanding system as defined in claim 18, wherein the cyclone separation device is connected with the sanding tool with a flexible hose having a smooth inner surface.

1/2

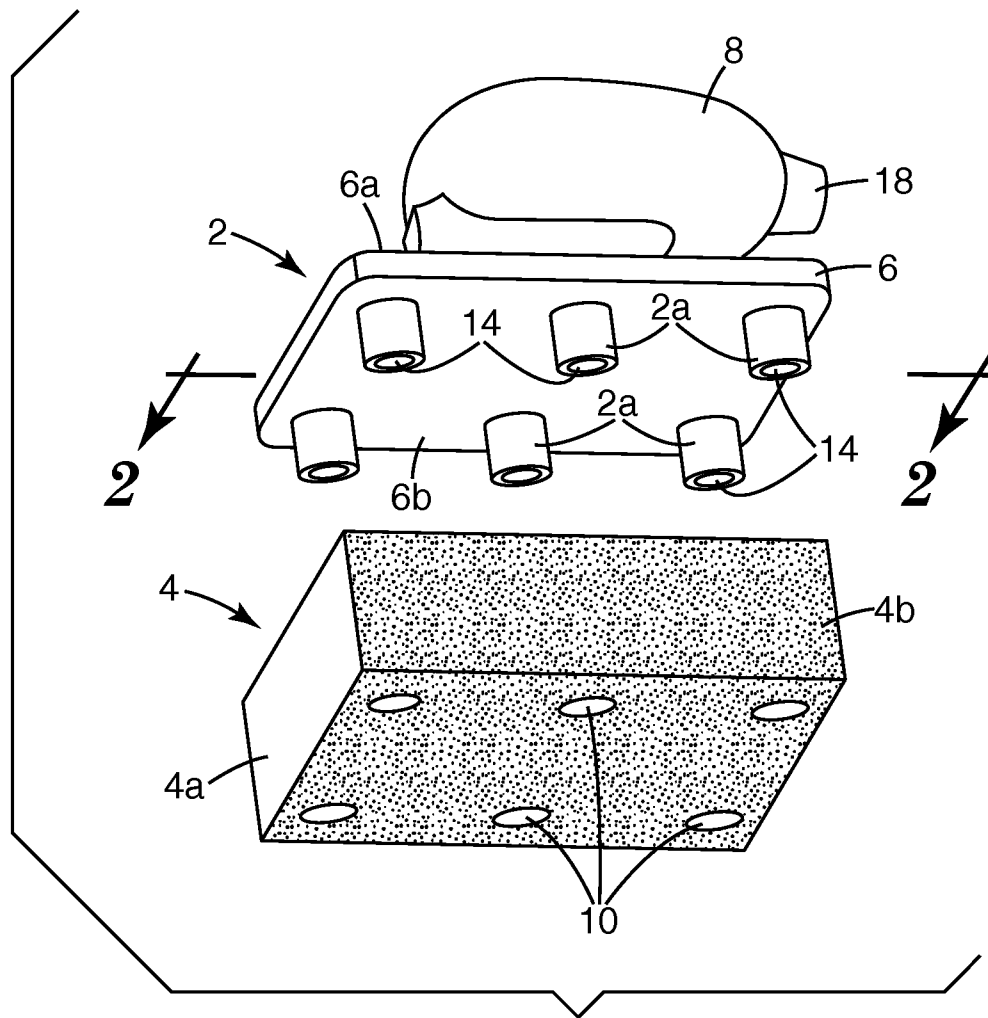

Fig. 1

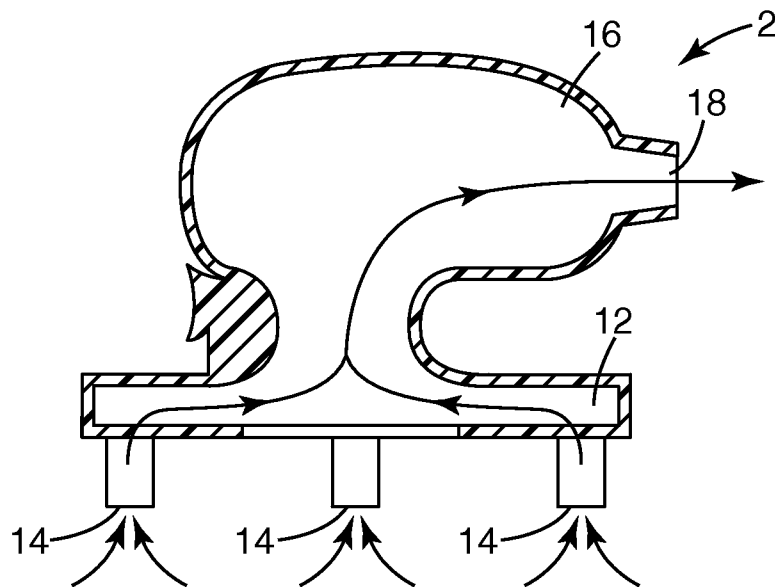

Fig. 2

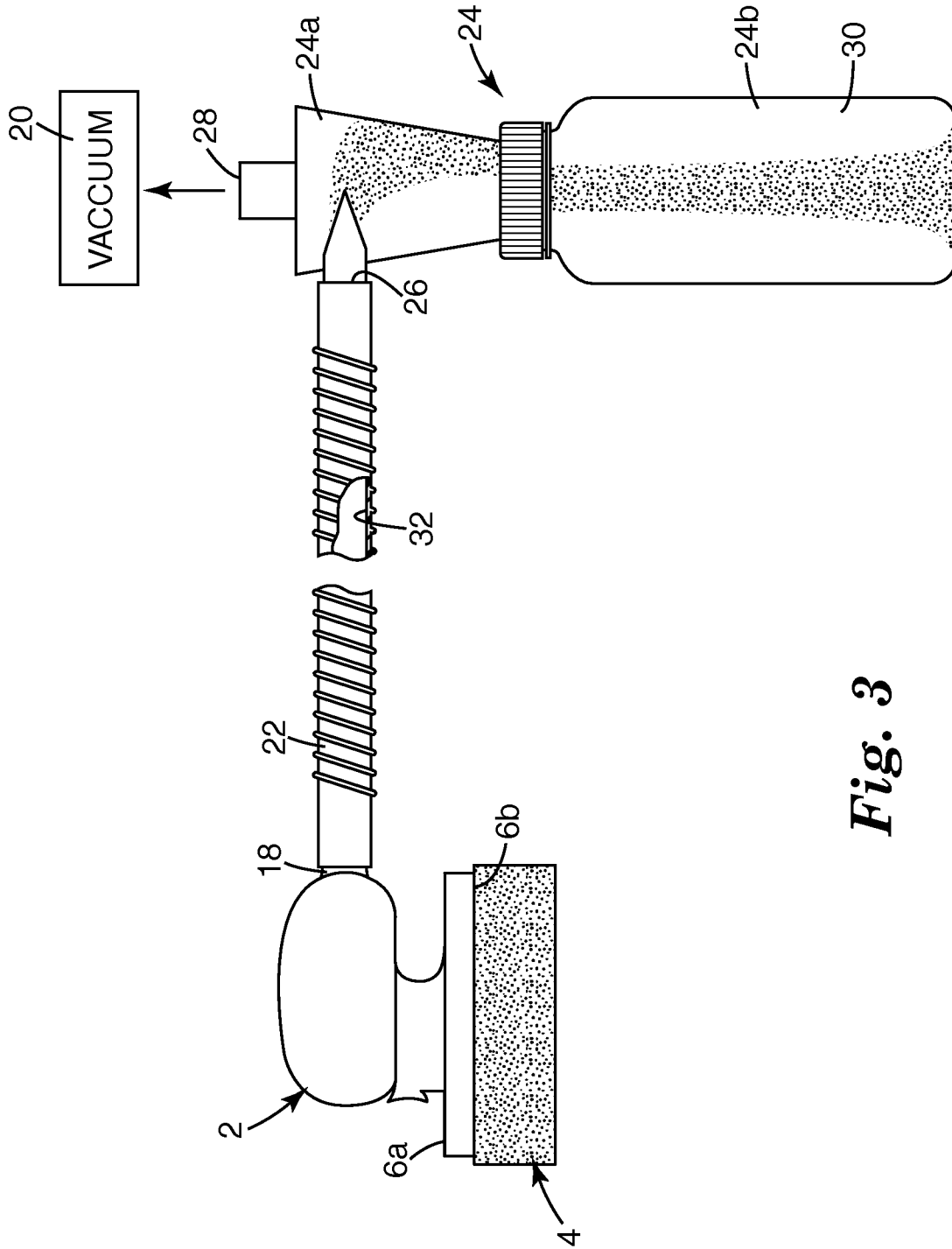

Fig. 3

A. CLASSIFICATION OF SUBJECT MATTER***B24B 55/10(2006.01)i***

According to International Patent Classification (IPC) or to both national classification and IPC

B. FIELDS SEARCHED

Minimum documentation searched (classification system followed by classification symbols)

IPC 8 : B24B 55/10, B24B 23/04, B24D 15/00

Documentation searched other than minimum documentation to the extent that such documents are included in the fields searched

Korean utility models and applications for utility models since 1975.

Japanese utility models and applications for utility models since 1975.

Electronic data base consulted during the international search (name of data base and, where practicable, search terms used)

e-KIPASS(KIPO internal) "Keyword: sanding, abrasive, post"

C. DOCUMENTS CONSIDERED TO BE RELEVANT

Category*	Citation of document, with indication, where appropriate, of the relevant passages	Relevant to claim No.
X A	US 6379237 B1 (WINSTON LIVINGSTON GORDON) 30 April 2002 See abstract; figures 1, 4-7; column 2, line 36-column 3, line 27; claims 1-5.	1-3, 11, 12, 16 4-10, 13-15, 17-19
A	US 5337523 A (DAVID C. WALSH) 16 August 1994 See abstract; figures 2, 3; column 3, line 41-column 6, line 50.	1-19
A	US 4023312 A (JON O. STICKNEY) 17 May 1977 See abstract; figure 1; column 2, lines 14-40.	1-19
A	US 3964213 A (ALTON E. TOBEY) 22 June 1976 See figures 1, 5; column 2, lines 42-59.	1-19
A	JP 08-309654 A (RYOBI LTD.) 26 November 1996 See abstract; figures 1, 3, 4; paragraphs 7-10.	1-19

 Further documents are listed in the continuation of Box C. See patent family annex.

* Special categories of cited documents:

"A" document defining the general state of the art which is not considered to be of particular relevance

"E" earlier application or patent but published on or after the international filing date

"L" document which may throw doubts on priority claim(s) or which is cited to establish the publication date of citation or other special reason (as specified)

"O" document referring to an oral disclosure, use, exhibition or other means

"P" document published prior to the international filing date but later than the priority date claimed

"T" later document published after the international filing date or priority date and not in conflict with the application but cited to understand the principle or theory underlying the invention

"X" document of particular relevance; the claimed invention cannot be considered novel or cannot be considered to involve an inventive step when the document is taken alone

"Y" document of particular relevance; the claimed invention cannot be considered to involve an inventive step when the document is combined with one or more other such documents, such combination being obvious to a person skilled in the art

"&" document member of the same patent family

Date of the actual completion of the international search

01 APRIL 2008 (01.04.2008)

Date of mailing of the international search report

01 APRIL 2008 (01.04.2008)

Name and mailing address of the ISA/KR

Korean Intellectual Property Office
Government Complex-Daejeon, 139 Seonsa-ro, Seo-
gu, Daejeon 302-701, Republic of Korea

Facsimile No. 82-42-472-7140

Authorized officer

CHEE Seon Koo

Telephone No. 82-42-481-8539



INTERNATIONAL SEARCH REPORT

Information on patent family members

International application No.

PCT/US2007/086041

Patent document cited in search report	Publication date	Patent family member(s)	Publication date
US6379237B1	30.04.2002	US6379237BA	30.04.2002
US5337523A	16.08.1994	W09412318A1	09.06.1994
US4023312A	17.05.1977	NONE	
US3964213A	22.06.1976	NONE	
JP08309654A	26.11.1996	JP8309654A2 US5681213A	26.11.1996 28.10.1997