

A. J. COFFEE.
FIRE ALARM TELEGRAPH.

No. 481,847.

Patented Aug. 30, 1892.

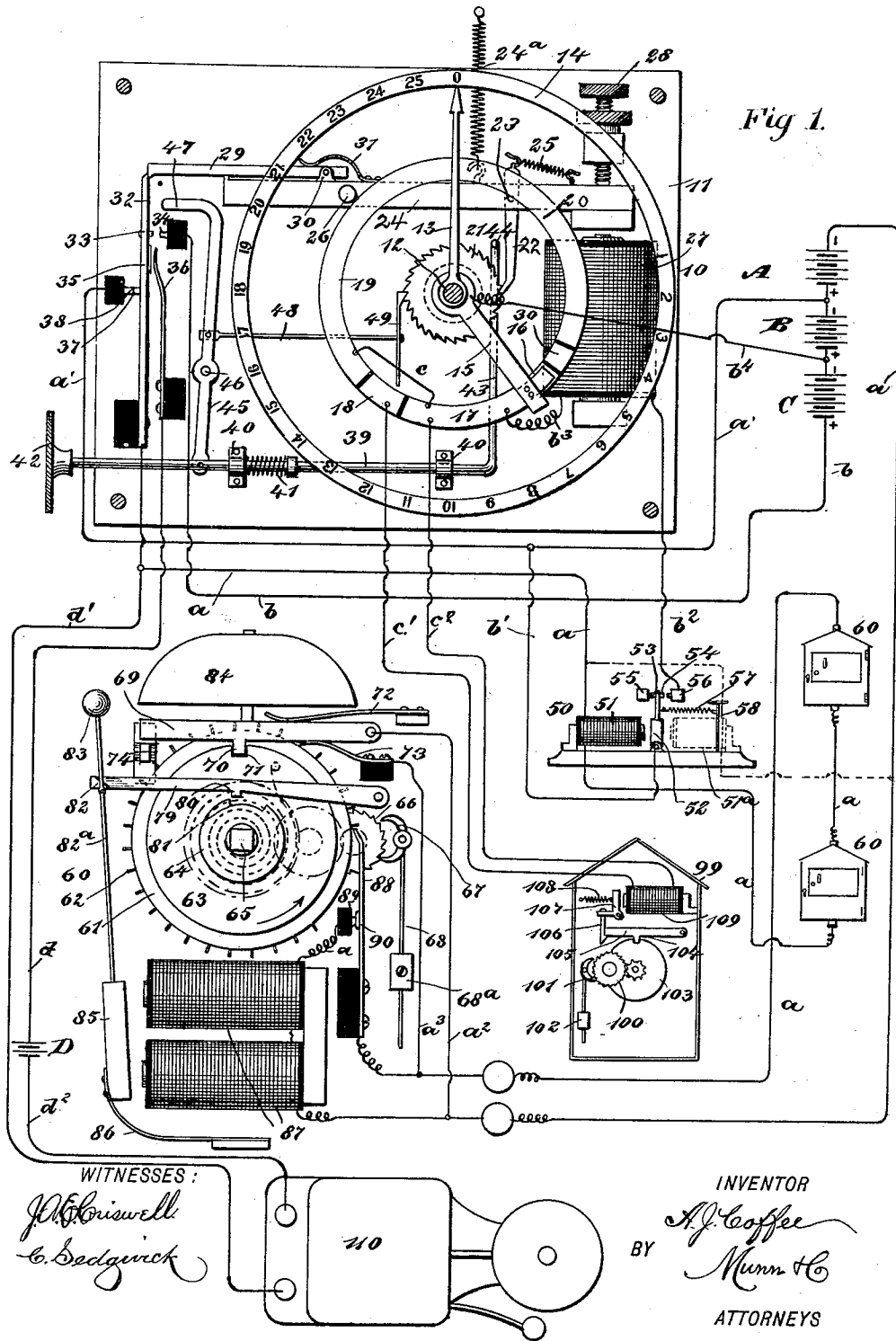

WITNESSES:
J. H. Griswell
C. Sedgwick

INVENTOR
A. J. Coffee
 BY *Munn & Co*
 ATTORNEYS

A. J. COFFEE.
FIRE ALARM TELEGRAPH.

No. 481,847.

Patented Aug. 30, 1892.

Fig. 2.

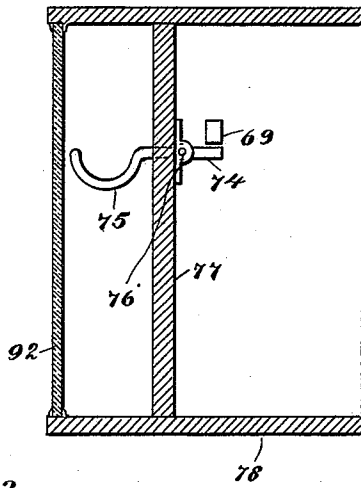

Fig. 3.

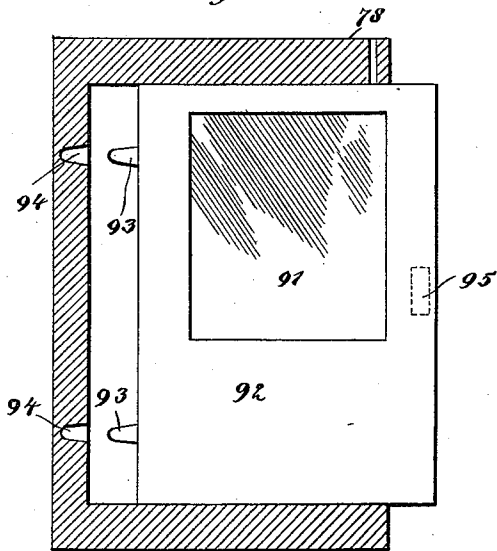
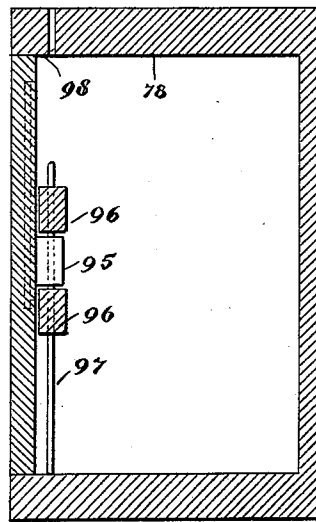

Fig. 4.



WITNESSES:

J. H. Griswell
C. Sedgwick

INVENTOR

A. J. Coffee
BY

Munn & Co
ATTORNEYS.

UNITED STATES PATENT OFFICE.

ANDREW J. COFFEE, OF PORTLAND, OREGON.

FIRE-ALARM TELEGRAPH.

SPECIFICATION forming part of Letters Patent No. 481,847, dated August 30, 1892.

Application filed May 12, 1892. Serial No. 432,730. (No model.)

To all whom it may concern:

Be it known that I, ANDREW J. COFFEE, of Portland, in the county of Multnomah and State of Oregon, have invented a new and Improved Fire-Alarm Telegraph, of which the following is a full, clear, and exact description.

My invention relates to improvements in fire-alarm telegraphs, and more especially to that class of fire-alarms in which a system of auxiliary boxes is used in connection with the main district or signal boxes; and the object of my invention is to provide a means by which the fire department can locate the exact auxiliary that has been turned in, and, also, to construct and arrange the apparatus so that no two boxes can interfere in a way to cause confusion.

A further object of the invention is to produce a simple and easily-operated mechanism for the purpose described and to provide for a return-signal at the auxiliary box, so that the person ringing in the alarm may know that everything is in proper working order.

To this end my invention consists in certain features of construction and combinations of parts, which will be hereinafter described and claimed.

Reference is to be had to the accompanying drawings, forming a part of this specification, in which similar figures and letters of reference indicate corresponding parts in all the views.

Figure 1 is a diagrammatic view of the entire system embodying my invention. Fig. 2 is a broken vertical section of one of the auxiliary boxes, showing in detail the tripping-hook for ringing in an alarm. Fig. 3 is a sectional elevation of the box, showing in detail the door with the glass therein, and Fig. 4 is a section at right angles to that shown in Fig. 3 and shows the manner of fastening the door.

In carrying out my invention I provide a controller, which is connected with a series of auxiliary boxes and with the nearest signal-box, from which wires lead to the bell-tower in the usual way, and the current from the auxiliary boxes passes through the controller and from thence to the district signal-box.

The controller 10 is provided with a suitable base-board 11, to which the mechanism described below is secured, and this mechanism may be inclosed in a suitable case, pref-

erably of glass. Journaled centrally and transversely on the base 11 is a shaft 12, which may be provided with a thumb-nut, as shown by dotted lines in the drawings, and with any suitable mechanism for turning it, and the shaft carries an indicator or pointer 13, which moves over a dial 14, on which the numbers of the boxes are inscribed, and the shaft also carries an arm 15, which has at one end a brush 16, adapted to move over the segments 17, 18, 19, and 20 of a circular switch-board. These segments are insulated from each other, the segments 17 and 19 being connected by a wire, as hereinafter described, and the segments 17 and 18 being connected electrically with the main or district signal-box.

On the shaft 12 is a ratchet-wheel 21, which may be provided with any necessary number of teeth, according to the number of boxes to be employed, and this ratchet-wheel is engaged and turned by a depending pawl 22, which is pivoted, as shown at 23, on an armature-lever 24, above the shaft and at right angles thereto, the pawl being held normally in engagement with the ratchet-wheel by a spring 25, secured to the armature-lever and to the upper end of the pawl, which projects above the lever. The armature-lever 24 is fulcrumed, as shown at 26, is held upward by a spring 24^a, and swings vertically between the electro-magnet 27 at one side of the shaft and supported on the base 11 and an adjustable screw-stop 28. At the end of the lever opposite the magnet is a tripping-arm 29, which is pivoted on the upper side of the lever, as shown at 30, and which is normally pressed downward against the top of the lever by a spring 31. The free end of the arm 29 engages a contact or circuit-breaking lever 32, which is held on an insulated support and arranged vertically upon the base 11, and this contact-lever controls registering-contacts 33 and 34, 35 and 36, and 37 and 38, which are connected electrically with the operative parts of the apparatus, as hereinafter described, and the tripping-arm 29 holds the lever 32, so that all the contacts except 37 and 38 will be open.

A bent rod 39 is held to slide in suitable bearings 40 on the base 11 and beneath the shaft 12, the rod being normally repressed by a spring 41, and its outer end terminates in

a head 42, which may project through the ends of the controller and by means of which the rod 39 may be moved and the controller reset, as described presently. The inner end of the rod is bent upward, as shown at 43, and it terminates in a bent end 44, adapted to be brought into contact with the inner face of the pawl 22, and by pushing the rod inward the pawl may be thrown out of gear with the ratchet-wheel 21, so as to permit of the resetting of the controller. The rod 39 is also pivotally connected with a lever 45, which is fulcrumed, as shown at 46, on the opposite side of the ratchet-wheel from the pawl 22, and the upper end of the lever 45 is bent outward, as shown at 47, and its end serves as a stop against which the upper end of the contact-lever 32 may rest.

Pivoted to the lever 45, above its fulcrum, is a horizontal rod 48, which carries at its inner end a pawl or detent 49, adapted to engage the ratchet-wheel 21 on the side opposite the pawl 22, and this prevents any accidental turning back of the ratchet-wheel. The controller after being once operated must be set by hand, and by pushing inward on the rod 39 it will be seen that both the pawls 22 and 49 will be thrown out of gear, and by means of the thumb-nut the shaft 12 may be turned back so as to reset the controller.

It will be seen from the foregoing description that when the magnet 27 is energized the armature-lever 24 will be depressed and the ratchet-wheel 21 turned, so as to carry the pointer 13 around the dial and so, also, as to carry the switch-arm 15 around the switch-board and enable it to close the circuit through the main or district signal-box, and this will be more fully described hereinafter.

The circuit through the controller and other parts of the apparatus is controlled in a measure by the relay 50, which operates as a circuit-breaker and which at the right time puts in sufficient battery-power to run the entire system, as described below. The relay has an electro-magnet 51, held on a suitable base, and opposite this is an armature 52, having contacts 53 and 54 at its free end, the contact 53 being adapted to engage the dead-contact 55 and the contact 54 being adapted to engage the live-contact 56, and when this latter engagement takes place the whole battery-power of the system is put in, as described hereinafter. The energizing of the magnet 51 holds the contact 53 upon the contact 55, and the armature is pulled in the opposite direction by a spring 57, secured to a support 58. Instead of the spring 57, however, a high-resistance magnet 51^a may be arranged on the side of the armature 52 opposite the magnet 51, and this magnet placed in a shunt of the local circuit, so that when the circuit is broken through the magnet 51 it will be closed through the magnet 51^a and the armature 52 swung over against the contact 56.

The auxiliary boxes 60 are connected up in series, as hereinafter described, and in each

box are connected wheels 61, 63, and 64, which are of gradually-reduced diameter and which are held to a shaft 65, having a square end, as shown in Fig. 1, so that it may be wound up against the tension of a coil-spring, (shown by dotted lines in said figure,) the spring being of the usual kind and adapted to rotate the several wheels. The wheel 61 has pins 62 on its periphery, which are adapted to engage a circuit-breaking lever, as described below. The number of pins on the wheel correspond to the number of the box plus eight, although this number is arbitrary; but it is a convenient number and provides against too sudden ringing and false alarms. For instance, the first eight breaks will carry the arm 15 of the controller to the segment 18, and the segment 17 will thus act as a safety device. It will be seen then that if a wire should be accidentally broken or crossed or a circuit made and broken several times while the switch-arm 15 is on the segment 17 no alarm is sounded.

To further illustrate, the wheel 61 for the box 23 would have thirty-one pins, the first eight carrying the arm 15 by repeated breaks to the segment 18 and the remainder sounding the alarm. The wheels have the usual connection with an escapement-wheel 66, the escapement-lever 67 being actuated by a pendulum-rod 68, having a weight 68^a, adjustably secured thereon, and this may be adjusted so as to regulate the speed of the clock-movement.

Above the wheel 63 is a tripping-lever 69, having on the under side a detent or lug 70, which registers with a recess 71 in the wheel, and the lug will be normally held in engagement with the recess so as to hold the several wheels in a stationary position. The lever 69 is normally pressed downward by a spring 72, and a spring 73 of less tension presses against its under side, the spring 73 being for the purpose of short-circuiting the box, as described below. The free end of the tripping-lever 69 extends above the shank 74 of the tripping-hook 75, which is best shown in Fig. 2, and this hook is fulcrumed, as shown at 76, on a partition 77 of the case 78, which forms a part of the box 60, and by pulling down upon the hook 75 the tripping-lever 69 is raised so as to release the circuit-breaking wheel and ring in an alarm.

Extending transversely across the face or side of the wheel 63 and above the wheel 64 is a freely-swinging non-interfering lever 79, which prevents the mechanism from being interfered with when another alarm is rung in, this lever 79 having a lug 80 on its lower side, which registers with an elongated recess 81 in the rim of the wheel 64. The free end of the non-interfering lever 79 has a beveled lug 82, which rests upon a stop on the hammer-rod 82^a, which is held in a nearly-vertical position in the box and has at its upper end a hammer 83, adapted to strike the bell 84. The lower end of the rod 82^a connects with an

armature 85, which is supported by a spring 86 and is actuated by the magnets 87.

At one side of the circuit-breaking wheel 61 is a spring-lever 88, which is held upon an insulated support, and the bent free end of this lever extends into the path of the pins 62. This lever has a contact 90, adapted to touch the contact 89, which is in connection with the magnets 87 of the local circuit.

The wall of the auxiliary box 60 or of the part 78 of the box is provided with a glass 91 at a point opposite the hook 75, this glass being secured in any suitable way in a door 92, which has at one edge tenons 93, adapted to enter mortises 94 in the case 78, and at the rear end of the door 92 is an inwardly-extending and vertically-located lug 95, adapted to enter between lugs 96, secured to the case and held above and below it, as shown in Fig. 4, and these lugs are also perforated so as to receive a pin 97, which extends through the lugs 95 and 96 and is dropped to place through an opening 98 in the top of the case. The glass 91 is broken when an alarm is to be pulled in, and after the glass is broken the pin 97 is removed, so as to permit the withdrawal of the door 92 and the insertion of a new one.

The district-box 99 is, with the exception of its tripping mechanism, like the common form of boxes and its connection with the bell-tower is not shown. It has a clockwork-gearing 100, controlled by an escapement 101 and weight 102, and the disk 103 of the clockwork is held normally by a detent 104 on a swinging lever 105, which is arranged above the disk, and the free end of the lever is engaged by a hook 106, adapted to be operated by a bell-crank 107, with the lower arm of which it is connected, and this bell-crank is swung one way by a spring 108 and in the opposite direction by a magnet 109, the upper arm of the bell-crank serving the purpose of an armature.

A watch-bell 110 is connected with the controller, and as soon as the contact-lever 32 moves—that is, as soon as an alarm is started—the bell 110 will begin to ring and will ring continuously until the apparatus is reset.

Both the controller and the auxiliary boxes must be reset by hand, as described below, after each operation. This construction is provided so as to guard against any possible confusion or false alarms in resetting.

The connections and circuits are as follows:

The local battery A is used for holding the mechanism normally in a closed circuit, and in connection with this batteries B and C are used, these being connected up in series and adapted to be switched on when necessary. A battery D is also used for operating the watch-bell 110. The circuit from the battery A is through the wire *a*, the auxiliary boxes 60, (the circuit in each box being through the magnets 87, the contacts 89 and 90, and the breaking-lever 88,) the relay-magnet 51, the contact-lever 32, the contacts 37 and 38, and the wire *a'* back to the battery. From the

batteries B and C the circuit from the battery C is through the wire *b*, the contacts 34 and 33, (when the latter are in connection,) the contact-lever 32 to wire *a*, electro-magnet 51, and through the auxiliary boxes 60 and wire *a* back to the batteries entering at A, through it to B, and through it to C. The battery B is used as a local when the outside or main circuit is open, and its current runs through the wire *b*⁴ to the arm 15 and brush 16, and to segment 17 through the wire *b*³ and electro-magnet 27, through wire *b*² to contact 56 and (when closed) contact 54, armature-lever 52, through wire *b'*, and a portion of wire *a'* back to battery B. When the auxiliary-box circuit is open after the first interruption and tripping of the lever 32, the battery B is giving all of its strength to the local or controller circuit; but when the auxiliary-box circuit is closed the battery B passes to the auxiliary-box circuit as the other path is broken at the contact-points 54 and 56. So we have the entire strength of the batteries A B C on the line when it is closed and so much of it as we need to operate the locals on the local when the line is open. The segments 17 and 19 are connected by a wire *c*, and the segments 18 and 17 of the switchboard connect by wires *c'* and *c*² with the magnet 109 of the district-box 99. From the battery D the circuit is through the wire *d*, the contact 36, the contact-lever 32, the wire *d'*, the watch-bell 110, and the wire *d*² back to the battery. The closed circuit of the battery A will hold the parts normally in the position shown in Fig. 1 and the local circuit will not be sufficient to operate the auxiliary-box mechanism, as this mechanism is short-circuited through the wires *a*² and *a*³, connecting two members of the wire *a* with the tripping-lever 69 and the spring 73.

The operation of the device is as follows: When an alarm is to be rung in from an auxiliary box, the glass 91 is broken and the hook 75 pulled down. This releases the tripping-lever 69 and permits the wheel 61 to start. From the foregoing description it will be remembered that the non-interfering lever 79 is held out of engagement with the wheel 64; but if at the time an alarm is started an alarm should have been already started from another box the magnets 87 being in the circuit would be energized and the armature 85 pulled so as to release the lever 79, and the detent or lug 80, dropping into the recess 81, would stop the wheels 64, 63, and 61, so that the alarm would not be rung and all confusion would be avoided. It will be noticed that the elongation of this recess 81 provides for a slight movement of the wheel before the recess passes out of the path of the detent, this being for the purpose of enabling the non-interfering lever to be sure and engage the wheel 64 in case another box should be rung in first; but if there is no interference the recess 81 will have passed from beneath the detent 80 before one of the pins 62 strikes

the free end of the lever 88. As soon as a pin strikes this lever it will push the contact 90 away from the contact 89, thus breaking the local closed circuit and permitting the relay-armature 52 to swing over and bring the contacts 54 and 56 together. This switches on the entire force of the batteries, and the magnet 27, being energized, will pull down the armature-lever 24 and cause the ratchet-wheel 21 to be moved, thus carrying forward the pointer 13 and the switch-arm 15. It will be seen that as the pins 62 pass over the lever 88 the circuit will be alternately opened and closed, so that the vibrations will be transmitted through the magnet 27 and an up-and-down movement imparted to the pawl 22, thus carrying forward the switch-arm 15 and the indicator. It will also be seen that at the first movement of the armature-lever 24 the tripping-arm 29 will be raised and the contacts 33 and 34 and 35 and 36 brought together, thus closing the circuit through the entire apparatus, including the watch-bell 110, which will immediately begin ringing.

By reference to Fig. 1 it will be seen that a certain number of breaks are necessary to carry the switch-arm 15 so as to bring the brush 16 onto the segment 18 of the switchboard, and in practice eight breaks will be a convenient number. The object of this is to prevent any false alarms. When the brush reaches the segment 18, the indicator or pointer 13 will indicate the box "1," and when the brush reaches this segment the connection will be made through the district-box 99, the local circuit being in part from the contact 56 through the wire b^2 , the electro-magnet 27, the wire b^3 , the segment 17, the wire c^2 , the magnet 109, the wire c' , the segment 18, the brush 16, the switch-arm 15, and the wire b^4 to the battery B. When the magnet 109 is energized, it tilts the bell-crank 107 and lifts the hook 106 and lever 105, thus permitting the clock-weight 102 to turn, thus ringing an alarm in the usual way. When the auxiliary-box wheels have turned a complete revolution, the detents 70 and 80 will drop back to place, thus stopping the wheels. When the brush 16 strikes the segment 18, the box "1" will be indicated on the dial, and the next break will be box "2," and so on. The last segment 20 of the switchboard is disconnected from the others and represents the highest number on the dial—that is, when the brush has traveled around to this point it will have reached the capacity of the dial; but, if desired, the terminal segment 20 may be connected with another dial and a correspondingly-high number recorded.

Where the dial is not to be used, it is obvious that only the segments 17 and 18 and a short segment on the opposite side of the segment 18 from the segment 17 need be used.

Having thus described my invention, I claim as new and desire to secure by Letters Patent—

1. In a fire-alarm telegraph, a controller

having operative electrical connections with a signal-box, auxiliary boxes arranged in series and connected electrically with the controller, and an automatic and permanent lock for the auxiliary-box mechanism, substantially as described.

2. A fire-alarm telegraph comprising a controller having operative electrical connections with a signal-box, auxiliary boxes arranged in series and electrically connected with the controller, manually-operated means for setting the controller mechanism, and automatic locks to permanently lock said mechanism, substantially as described.

3. In a fire-alarm telegraph, a controller comprising a circular switchboard having insulated segments operatively connected with a signal-box, a switch-arm held to move over the switchboard, a magnet and a vibrating armature held adjacent to the switchboard, a ratchet connection between the armature and the switch-arm, and manually-operated means for throwing the ratchet out of gear, substantially as described.

4. In a fire-alarm telegraph, a controller comprising a circular switchboard having insulated segments operatively connected with a signal-box, a central shaft arranged within the switchboard, a numbered dial arranged concentric with the switchboard, an indicating pointer carried by the shaft and adapted to move over the dial, a switch-arm secured to the shaft and held to move over the switchboard, a magnet and vibrating armature-lever arranged adjacent to the switchboard, a ratchet connection between the armature-lever and the shaft, and means for throwing the ratchet mechanism out of gear, substantially as described.

5. In a fire-alarm telegraph, a controller comprising a circular switchboard having operative electrical connections with a signal-box, a switch-arm held to move over the switchboard, a magnet and a vibrating armature-lever arranged adjacent to the switchboard, a ratchet connection between the armature-lever and the switch-arm, and a circuit-closer tripped by the first movement of the armature-lever and adapted to turn in an additional electric current, substantially as described.

6. In a fire-alarm telegraph, the combination, with the controller-switchboard having its segments operatively connected with the signal-box, of an electro-magnet adapted to connect with an auxiliary signal-box, a vibrating armature-lever held adjacent to the magnet, a ratchet connection between the lever and the switch-arm, a spring contact-lever adapted to close a circuit through a watch-bell and to turn an additional current through the controller, and means for tripping the contact-lever by the movement of the armature-lever, substantially as described.

7. In a fire-alarm telegraph, the auxiliary box comprising a clockwork-operated circuit-breaking wheel, a manually-tripped lever

held to normally lock the wheel, a non-interfering lever having a lug thereon to engage a recess in a wheel of the clockwork mechanism, a normally-short-circuited magnet and armature adapted to hold the non-interfering lever out of engagement with the clockwork mechanism, and means for switching the current through the magnet by the lifting of the tripping-lever, substantially as described.

8. In a fire-alarm telegraph, an auxiliary box comprising a circuit-breaking wheel adapted to make and break connections with a controller, a manually-operated tripping-lever held to normally lock the circuit-breaking wheel, a recessed wheel connected with the circuit-breaking wheel, a non-interfering lever having a lug adapted to drop into the recess of the wheel, a normally-short-circuited magnet arranged within the box, an armature arranged opposite the magnet and having a bell-hammer connected therewith, a bell ar-

ranged in the path of the hammer, a stop secured to the hammer-rod and adapted to support the non-interfering lever, and means for putting in the magnet by the lifting of the tripping-lever, substantially as described.

9. In a fire-alarm telegraph, the combination, with the segmental switchboard of the controller and the signal-box operated by clockwork mechanism, of a swinging lever held to normally lock the signal-box mechanism, a magnet and armature arranged above the lever, a hook operated by the armature and adapted to raise the lever, and an electrically-operated switch-arm adapted to move over the switchboard and close the circuit through the signal-box magnet, substantially as described.

ANDREW J. COFFEE.

Witnesses:

O. F. PAXTON,
A. B. CRAWFORD.