

J. RIBEYRON.
ROCK CRUSHING MACHINERY.
APPLICATION FILED DEC. 27, 1911.

1,053,220.

Patented Feb. 18, 1913.

2 SHEETS—SHEET 1.

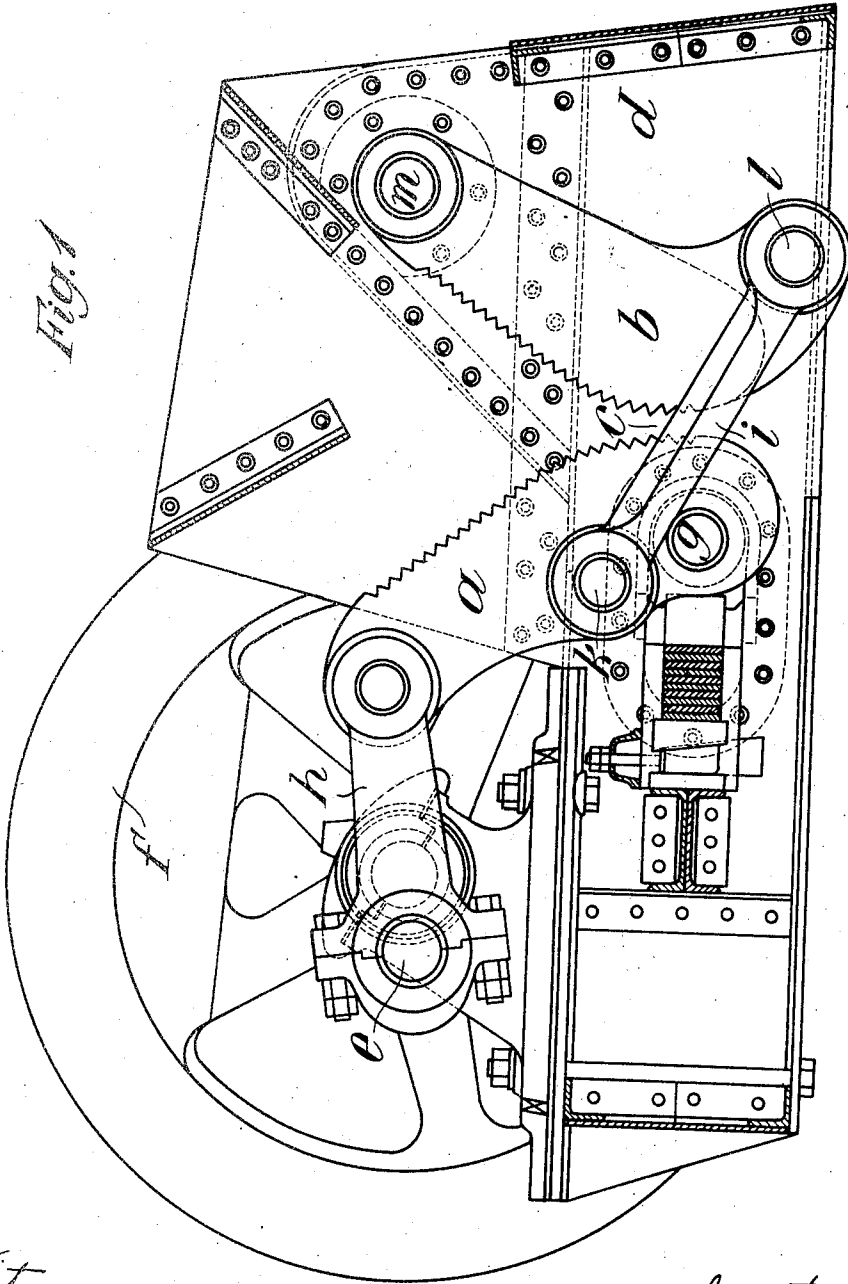

Fig. 1

Witnesses
Wm. F. Davidson
A. E. Bready

Inventor
Jean Ribeyron
Berrett Moore
Atty.

J. RIBEYRON.
ROCK CRUSHING MACHINERY.
APPLICATION FILED DEC. 27, 1911.

1,053,220.

Patented Feb. 18, 1913.

2 SHEETS—SHEET 2.

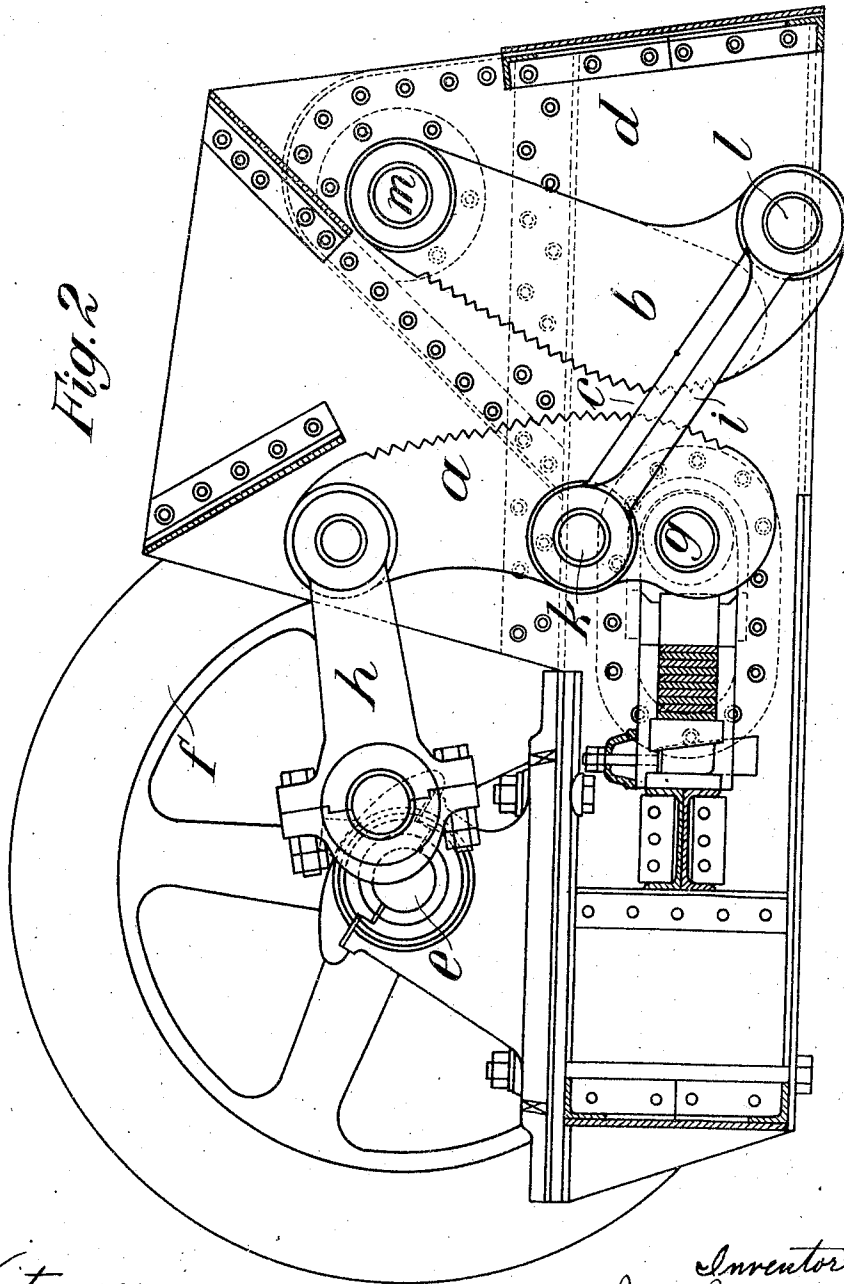

Witnesses

Wm. F. Davidson
H. E. Bready

Inventor
Jean Ribeyron
Percy H. Moore
Atty.

UNITED STATES PATENT OFFICE

JEAN RIBEYRON, OF SOSNOWICE, RUSSIA.

ROCK-CRUSHING MACHINERY.

1,053,220.

Specification of Letters Patent.

Patented Feb. 18, 1913.

Application filed December 27, 1911. Serial No. 668,125.

To all whom it may concern:

Be it known that I, JEAN RIBEYRON, a citizen of France, and residing at Sosnowice, Empire of Russia, have invented certain new and useful Improvements in Rock-Crushing Machinery, of which the following is a full, clear, and exact description.

In connection with most of the known rock crushing engines or machines it has been customary to employ one stationary and one movable jaw, with the result that the outlet opening for the crushed or broken rock, usually varied with the oscillations of the movable jaw.

The object of the present invention is to provide a rock crushing machine in which the outlet opening for the crushed rock is kept substantially uniform in size during all the movements of the crushing jaws, so that the rock will be disintegrated in substantially equal size throughout. This object is attained by making both jaws movable and connecting them up in such manner that the distance apart of the jaws at the outlet end for the rock remains substantially the same throughout the oscillatory movements of the said jaws necessary for crushing or disintegrating the rock.

In order to render the present specification easily intelligible, reference is had to the accompanying drawings which represent an embodiment of the invention.

Figure 1 is a view partly in section showing the jaws in the opened position and Fig. 2 is a view partly in section in the closed position.

The crushing jaws *a* and *b* are operated by means of a crank or eccentric shaft *e* having a flywheel *f*. The jaw *a* is mounted at its lower end on a spring pressed pivot *g* having a very strong spring which only allows the pivot to move in the event of

very hard material or metal coming between the jaws, which it is impossible to crush. The jaw *b* is pivotally supported at its upper end on a pivot *m*. Both pivots *m* and *g* are supported in the frame *d* and the two jaws *a* and *b* are coupled by means of a coupling bar or coupling bars *i* engaging pins *k* and *l* respectively of the said jaws *a* and *b*. The upper part of the jaw *a* is coupled by means of a connecting rod *h* to the crank or eccentric of the driving shaft. As the latter revolves, the upper parts of the two jaws *a* and *b* will be alternately oscillated from the position shown in Fig. 1 to that shown in Fig. 2 and vice versa, but the outlet opening *c* at the bottom for the crushed rock will remain the same size so that the rock will be crushed to a uniform size before it can leave the machine.

The degree of fineness to which the rock is crushed may be varied, by lengthening or shortening the rod or rods *i* or by making the position of the pivots *k* and *l* adjustable.

I claim as my invention:—

In a rock crushing machine comprising a driven shaft and crushing jaws operated by the same, the combination of pivotal supports for the said jaws at opposite ends of each jaw, a connecting rod to operate one jaw from the driving shaft and coupling means to connect the lower end of the driven jaw above its pivot to the lower end of the second jaw.

In testimony whereof I affix my signature in the presence of two witnesses.

JEAN RIBEYRON.

Witnesses:

FRANK G. PORTS,
ERNST KATZ.