



US 20090060754A1

(19) **United States**
(12) **Patent Application Publication**
Matsumura

(10) **Pub. No.: US 2009/0060754 A1**
(43) **Pub. Date: Mar. 5, 2009**

(54) **HYBRID COMPRESSOR**

(52) **U.S. Cl. 417/205**

(76) **Inventor: Hideki Matsumura, Gunma (JP)**

(57) **ABSTRACT**

Correspondence Address:
BAKER BOTTS LLP
C/O INTELLECTUAL PROPERTY DEPARTMENT
THE WARNER, SUITE 1300, 1299 PENNSYLVANIA AVE, NW
WASHINGTON, DC 20004-2400 (US)

A hybrid compressor has a first compression mechanism driven only by an external drive source; a second compression mechanism driven only by a built-in electric motor; suction paths for sucking gas to be compressed into the first compression mechanism; communication paths for sucking the gas from the first compression mechanism side into an electric motor side suction chamber; and suction passageways for sucking the gas from the electric motor side suction chamber to the second compression mechanism side. The positions and/or number of the communication paths and/or the suction passageways, and/or the positions and/or number of communication openings, which are openings of the communication paths and opened at the electric motor side suction chamber, and/or suction openings, which are openings of the suction passageways, opened at the electric motor side suction chamber, and located on a side opposite to the side of the communication openings, are limited so that, with respect to at least a part of the gas sucked into the electric motor side suction chamber via the communication paths, a gas flow is formed from the communication openings to the suction openings. In this structure, a built-in electric motor section can be appropriately cooled over a wider area by the sucked gas, so that a rise in temperature of the motor section can be properly suppressed.

(21) **Appl. No.: 11/909,601**

(22) **PCT Filed: Mar. 30, 2006**

(86) **PCT No.: PCT/JP2006/306644**

§ 371 (c)(1),
(2), (4) **Date: Sep. 24, 2007**

(30) **Foreign Application Priority Data**

Apr. 1, 2005 (JP) 2005-105736

Publication Classification

(51) **Int. Cl.**
F04B 23/08 (2006.01)

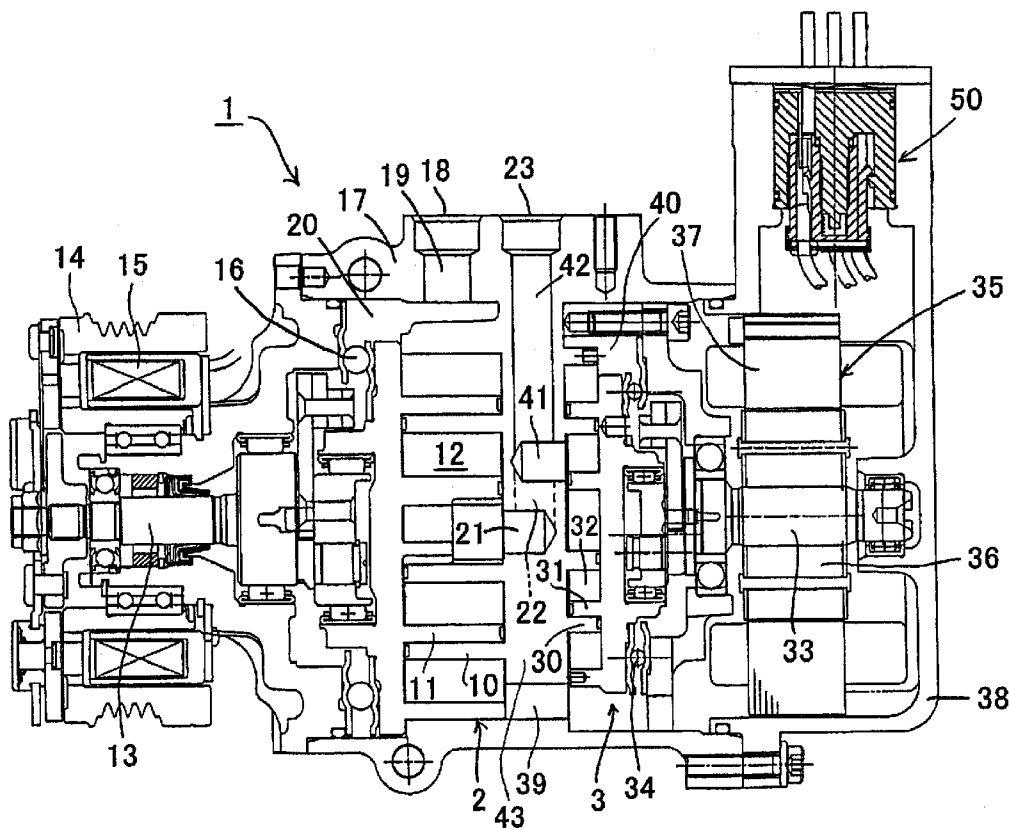

FIG. 1

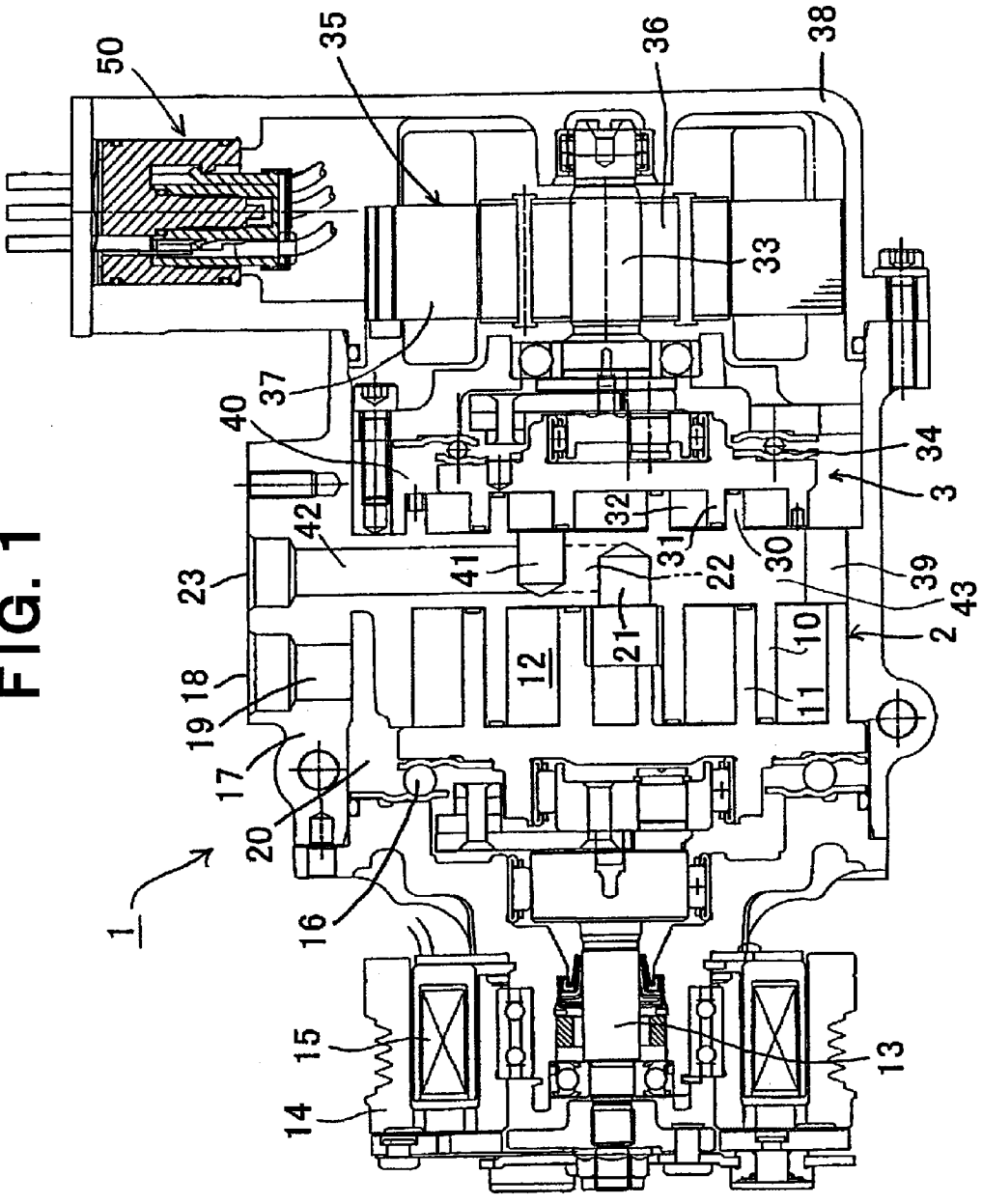

FIG. 2

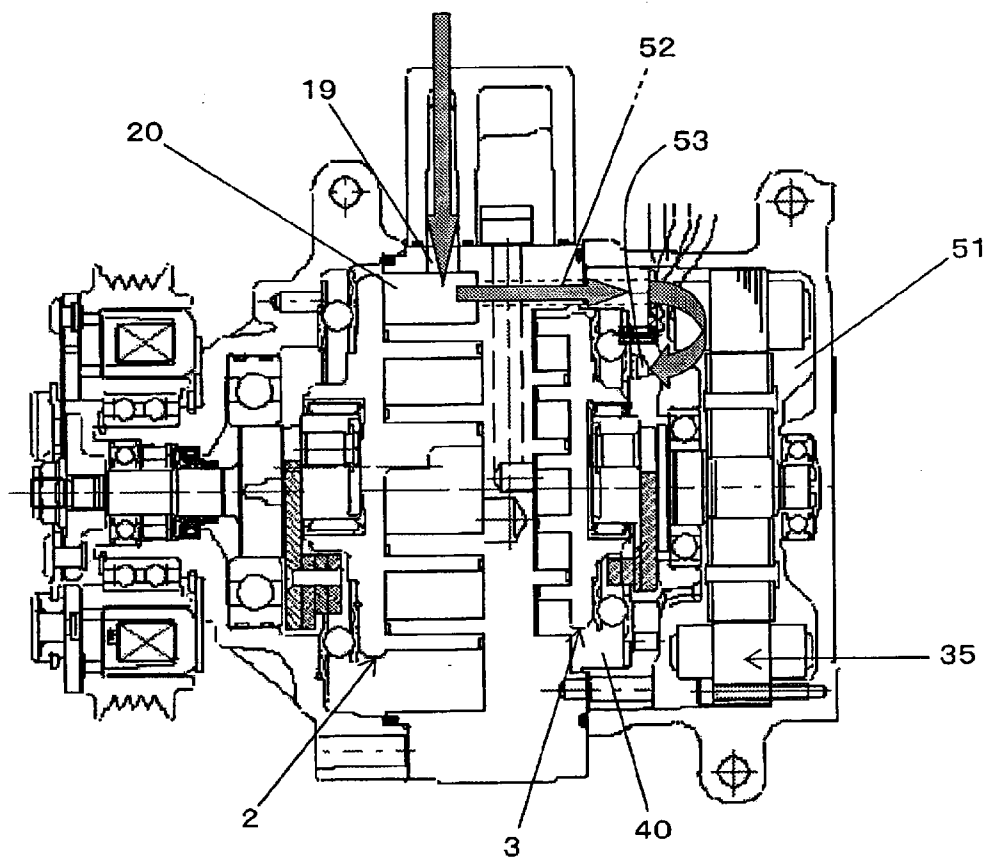

FIG. 3

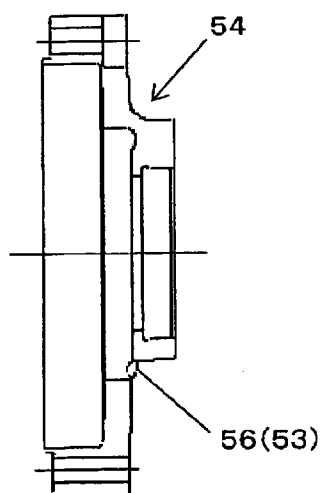

FIG. 4

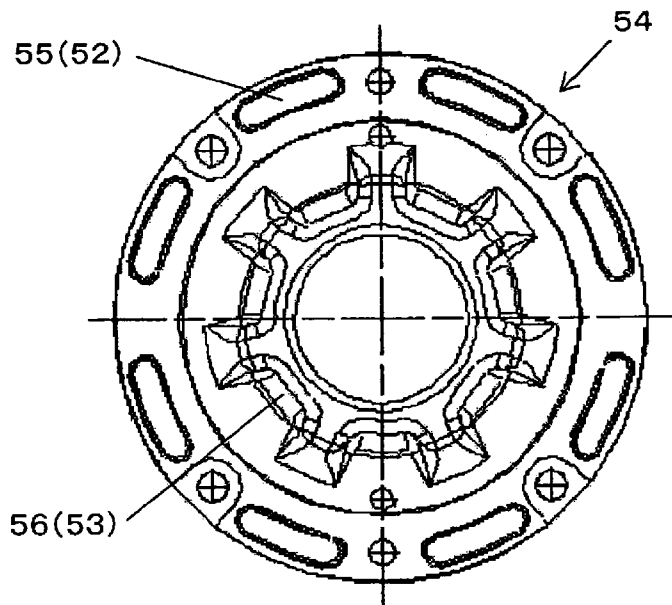

FIG. 5

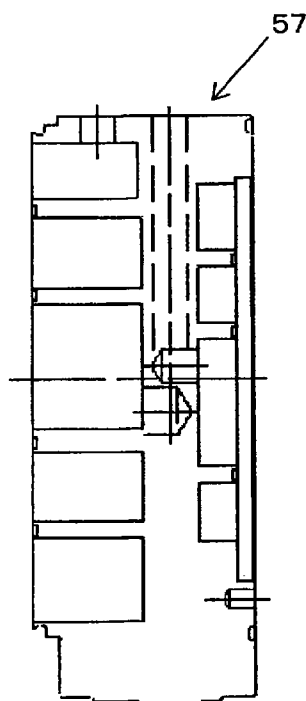

FIG. 6

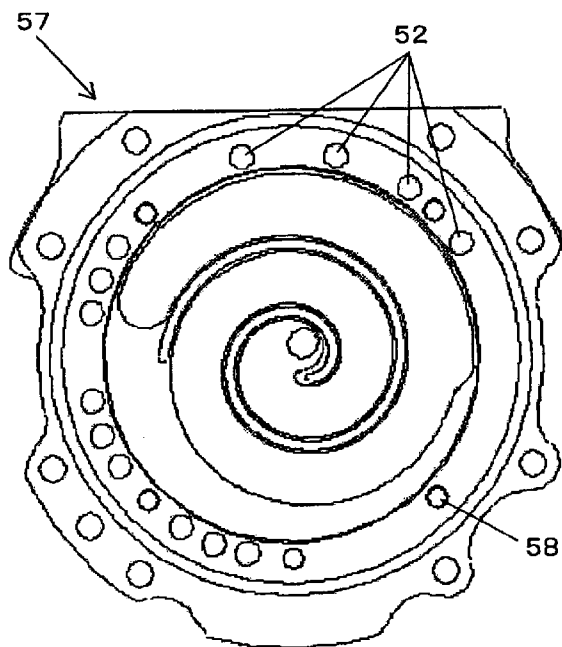

FIG. 7

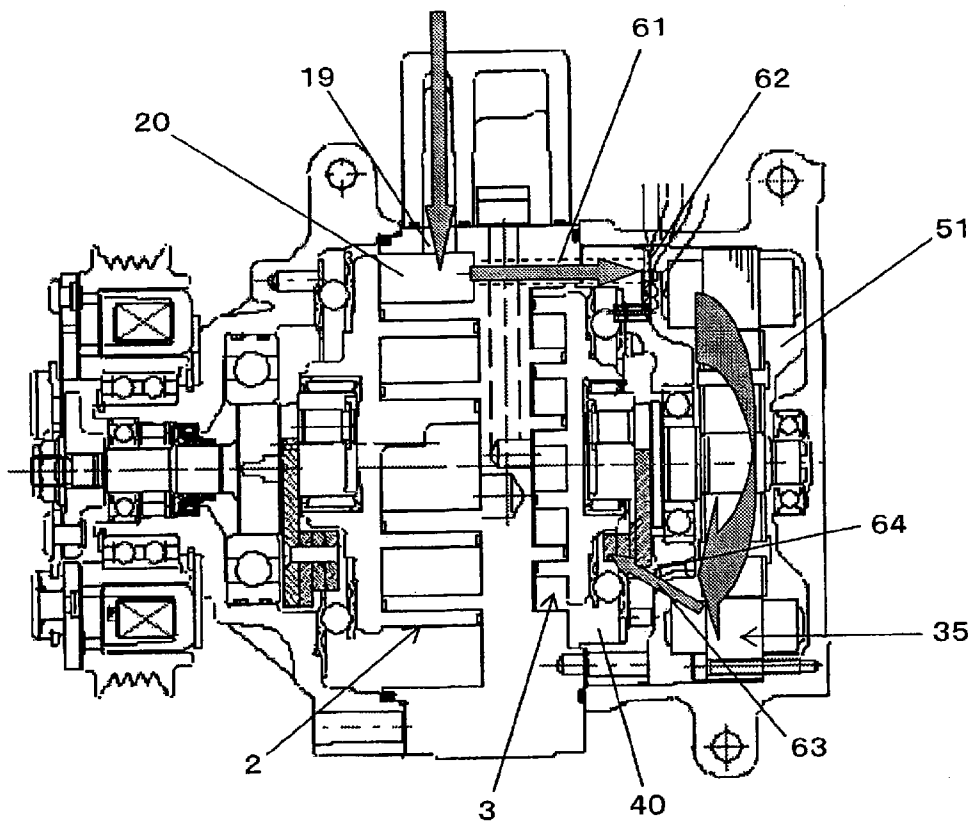

FIG. 8

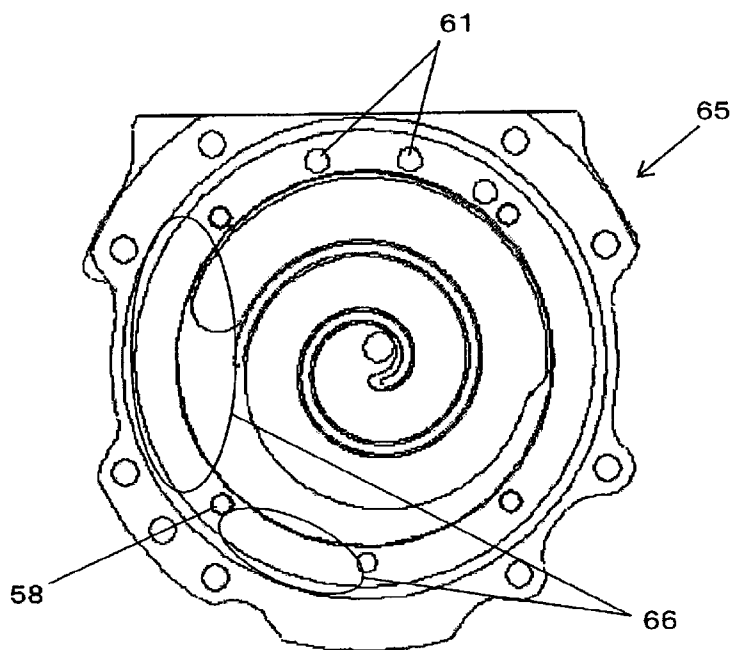
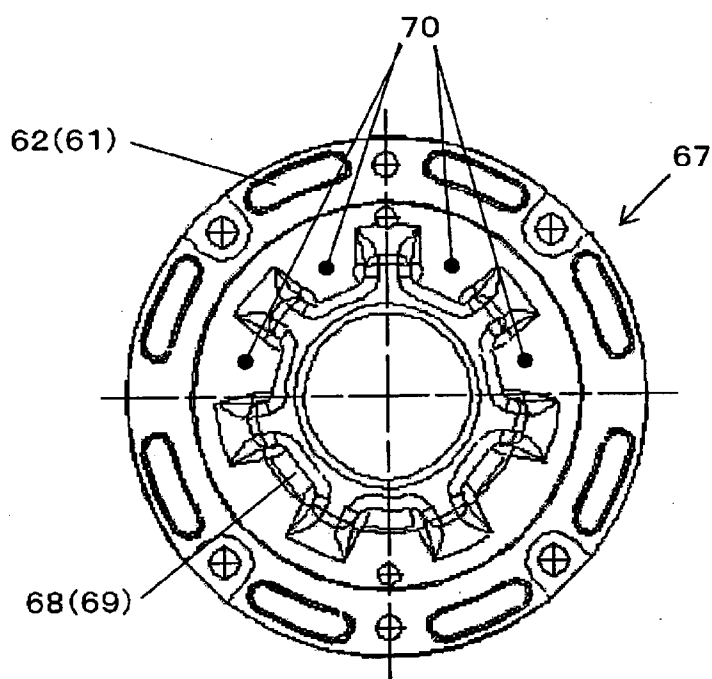

FIG. 9



HYBRID COMPRESSOR

TECHNICAL FIELD OF THE INVENTION

[0001] The present invention relates to a hybrid compressor in which a first compression mechanism driven by an external drive source and a second compression mechanism driven by a built-in electric motor are assembled integrally and which is used in air conditioning systems for vehicles, etc., and specifically, to a hybrid compressor the motor section of which can be cooled more effectively.

BACKGROUND ART OF THE INVENTION

[0002] Various proposals have been carried out for this type of hybrid compressors (for example, Patent document 1). A conventional hybrid compressor has a structure, for example, as shown in FIG. 1. Hybrid compressor 1 depicted in FIG. 1 is a scroll type compressor, and has a first compression mechanism 2 and a second compression mechanism 3. First compression mechanism 2 has a fixed scroll 10, a movable scroll 11 forming a plurality of pairs of operational spaces (fluid pockets) 12 by engaging with fixed scroll 10, a drive shaft 13 driving movable scroll 11 at an orbital movement by engaging with movable scroll 11, an electromagnetic clutch 15 for an on-off operation of the transmission of a driving force between a pulley 14, to which the driving force from a drive source for running a vehicle (not shown) provided as an external drive source is transmitted via a belt, and the drive shaft 13, a ball coupling 16 for preventing the rotation of movable scroll 11, and a suction port 18 formed on a casing 17. The gas to be compressed (for example, refrigerant) sucked from suction port 18 into a suction chamber 20 through a suction path 19 is taken into operational spaces 12, the operational spaces 12 are moved toward the center of fixed scroll 10 while the volumes of the operational spaces 12 are decreased, and by this operation, the refrigerant gas in the operational spaces 12 is compressed. A discharge hole 21 is formed on the central portion of fixed scroll 10, and the compressed refrigerant gas is discharged to a high-pressure side of an external refrigerant circuit through the discharge hole 21, a discharge path 22 and a discharge port 23.

[0003] On the other hand, second compression mechanism 3 has a fixed scroll 30, a movable scroll 31 forming a plurality of pairs of operational spaces (fluid pockets) 32 by engaging with fixed scroll 30, a drive shaft 33 driving movable scroll 31 at an orbital movement by engaging with movable scroll 31, and a ball coupling 34 for preventing the rotation of movable scroll 31. An electric motor 35 is incorporated in order to drive the drive shaft 33 of this second compression mechanism 3. Electric motor 35 has a rotor 36 fixed to drive shaft 33 and a stator 37 having a motor coil part, the stator 37 is fixed to a stator housing 38 or a stator housing 38 which is formed as a part of the compressor housing, and the whole of electric motor 35 is contained in the stator housing 38. An electricity is supplied to electric motor 35 via a power supply portion 50. In this second compression mechanism 3, the gas to be compressed (for example, refrigerant) sucked from suction port 18 into suction chamber 20 of first compression mechanism 2 is sucked into a suction chamber 40 of second compression mechanism 3 and a portion of electric motor 35 (an electric motor side suction chamber) through a communication path 39. The gas sucked into suction chamber 40 of second compression mechanism 3 is taken into operational spaces 32, the operational spaces 32 are moved toward the center of fixed

scroll 30 while the volumes of the operational spaces 32 are decreased, and by this operation, the refrigerant gas in the operational spaces 32 is compressed. A discharge hole 41 is formed on the central portion of fixed scroll 30, and the compressed refrigerant gas is discharged to the high-pressure side of the external refrigerant circuit through the discharge hole 41 and a discharge path 42.

[0004] Fixed scroll 10 of first compression mechanism 2 and fixed scroll 30 of second compression mechanism 3 are disposed back to back, and both fixed scrolls 10 and 30 are formed as an integrated fixed scroll member 43. In this example, communication path 39 is formed in this fixed scroll member 43.

[0005] In the hybrid compressor 1, when first compression mechanism 2 is only operated, an electricity is not supplied to electric motor 35 for driving second compression mechanism 3, and the electric motor 35 is not rotated. Therefore, second compression mechanism 3 does not operate. When the hybrid compressor 1 is driven only by electric motor 35, the electric motor 35 is turned to be on and rotated, the rotation of the electric motor 35 is transmitted to drive shaft 33 of second compression mechanism 3, and the orbital movement of movable scroll 31 is performed by the drive shaft 33. At that time, electromagnetic clutch 15 of first compression mechanism 2 is not excited, and the rotation of the drive source for running a vehicle as a first drive source is not transmitted to the first compression mechanism 2. Therefore, first compression mechanism 2 does not operate. When both first and second compression mechanisms 2 and 3 are driven simultaneously, the driving force from the drive source for running a vehicle is transmitted to movable scroll 11 of first compression mechanism 2 as well as electric motor 35 is turned to be on and the driving force thereof is transmitted to movable scroll 31 of second compression mechanism 3.

[0006] In the hybrid compressor 1 thus constructed, the control for switching between first compression mechanism 2 and second compression mechanism 3 and for simultaneous operation is performed in accordance with the load condition for cooling, etc. For example, in a light load condition where a great cooling ability is not required in a vehicle interior, a sole operation mode of the motor side having a small displacement (that is, second compression mechanism 3 side), or a simultaneous operation mode, in which the external drive source side having a great displacement relative to the motor side (that is, first compression mechanism 2 side) is rotated at a low rotational speed and the motor is also operated, is employed. The motor is operated through the control of the rotational speed, for example, by duty controlling the pulse voltage applied to the motor from a high voltage part in accordance with the demand from an exclusive drive control circuit. The motor coil part has a resistance, an electric current flows through the resistance, and the motor coil part is heated. The motor coil part is cooled by the passage of the refrigerant or by the thermal transmission from the motor coil part to the stator housing side and the heat radiation from the stator housing to the atmosphere, etc. The temperature of the motor coil part is decided depending upon the balance between the amount of the above-described heating and the amount of the above-described heat radiation. In the operational mode of sole drive of the motor side (second compression mechanism 3 side) or the simultaneous operational mode where first compression mechanism 2 is driven at a low rotational speed and second compression mechanism 3 is also driven, when the amount of the above-described heating of the motor coil

part exceeds the amount of the above-described heat radiation (for example, when the vehicle condition is turned from a highway running in a summer time to a vehicle stopping and idling in a parking zone), the temperature of the motor coil part may exceed an acceptable temperature, and at worst, the initiation of the motor may be damaged. Therefore, it is necessary to properly cool the motor portion including the motor coil part so that the temperature thereof does not exceed the acceptable temperature.

[0007] From the viewpoint described above, in particular, from the viewpoint of improvement of the cooling ability of the motor portion, a structure is known wherein the refrigerant sucked through the communication path is sucked into the suction chamber of the electric motor side, and therefrom, sucked into suction chamber **40** of second compression mechanism **3**. For example, as depicted in FIG. **2**, a structure is employed wherein the refrigerant sucked into suction chamber **20** of first compression mechanism **2** via suction path **19** is sucked into electric motor side suction chamber **51** through a communication path **52** extended up to the electric motor side suction chamber **51** (a communication path corresponding to communication path **39** depicted in FIG. **1**), the refrigerant is used for cooling the motor by being passed through the vicinity of motor **35**, and therefrom, the refrigerant is sucked into suction chamber **40** of second compression mechanism **3** via suction passageway **53**.

[0008] In the motor cooling structure using the refrigerant as shown in FIG. **2**, the respective members have been structured, for example, as shown in FIGS. **3** to **6**. FIGS. **3** and **4** depict an example of a center plate **54** provided between electric motor side suction chamber **51** and second compression mechanism **3**, and to this center plate **54**, communication paths **52** having communication openings **55** as openings at electric motor side suction chamber **51**, and suction passageways **53** having suction openings **56** as openings at electric motor side suction chamber **51**, are provided. As shown in FIG. **4**, communication openings **55** and suction openings **56** are almost over the entire circumference.

[0009] Further, FIGS. **5** and **6** depict an example of a fixed scroll member **57** which is formed by forming a fixed scroll of first compression mechanism **2** and a fixed scroll of second compression mechanism **3** integrally in a form of back to back, and in this fixed scroll member **57**, communication paths **52** are provided in the circumferential direction as shown in FIG. **6**. Where, symbols **58** represent bolt holes which are provided at four positions in the circumferential direction.

[0010] However, in the conventional hybrid compressor having the structure as depicted in FIGS. **3** to **6**, as shown by arrows in FIG. **2**, the refrigerant gas sucked into electric motor side suction chamber **51** from suction chamber **20** side of first compression mechanism **2** through communication path **52** and communication opening **55** is likely to be sucked to suction opening **56** which is located at a closest position relative to the communication opening **55**, and therefrom, the refrigerant gas is sucked into suction chamber **40** of second compression mechanism **3** via suction passageway **53**. Therefore, in a place apart from these communication opening **55** and suction opening **56**, there is a fear that the refrigerant gas stays in electric motor side suction chamber **51**. As a result, a motor portion, which is positioned apart from these communication opening **55** and suction opening **56**, may not be cooled sufficiently by the sucked gas, and it may be overheated.

Patent document 1: JP-A-2004-278339

DISCLOSURE OF THE INVENTION

Problems to be Solved by the Invention

[0011] Accordingly, an object of the present invention is to provide a structure of a hybrid compressor which can appropriately cool a section of a built-in electric motor over a wider area by sucked gas, thereby suppressing a rise in temperature of the motor section more properly, and further thereby making it possible to enlarge an available motor operational range.

Means for Solving the Problems

[0012] To achieve the above-described object, the present invention provides a hybrid compressor has a first compression mechanism driven only by an external drive source, a second compression mechanism driven only by a built-in electric motor, a suction path for sucking gas to be compressed into the first compression mechanism, a communication path for sucking the gas from the first compression mechanism side into an electric motor side suction chamber, and a suction passageway for sucking the gas from the electric motor side suction chamber to the second compression mechanism side, and the hybrid compressor is characterized in that positions and/or number of the communication path and/or the suction passageway, and/or positions and/or number of a communication opening, which is an opening of the communication path that is opened at the electric motor side suction chamber, and/or a suction opening, which is an opening of the suction passageway that is opened at the electric motor side suction chamber and located on a side opposite to the side of the communication opening, are limited so that, with respect to at least a part of the gas sucked into the electric motor side suction chamber via the communication path, a gas flow is formed from the communication opening to the suction opening.

[0013] In this hybrid compressor, a structure may be employed wherein the communication opening is provided only at a position on one side in the electric motor side suction chamber, and the suction opening is provided only at a position on a side opposite to the above-described one side in the electric motor side suction chamber.

[0014] Further, a structure may be employed wherein the communication opening, the communication path, the suction passageway and the suction opening are provided at plurality conditions, respectively.

[0015] Further, a structure may be employed wherein a center plate is provided between the electric motor side suction chamber and the second compression mechanism, and the communication opening and the suction opening are formed on the center plate.

[0016] Furthermore, a structure may be employed wherein a fixed scroll of the first compression mechanism and a fixed scroll of the second compression mechanism are integrally formed as a common fixed scroll member, and a part of the communication path is formed on the fixed scroll member.

[0017] Where, as the external drive source, a drive source for running a vehicle (including both an engine such as an internal combustion engine and an electric motor for running a vehicle in a case of an electric car, etc.) can be employed. Further, as the gas to be compressed, refrigerant can be employed.

[0018] In such a hybrid compressor according to the present invention, when a rise in temperature occurs in the built-in electric motor, particularly in its coil portion, by the

heating accompanying with increase of electric current, an excessive rise in temperature of the motor section may be appropriately suppressed as follows. Namely, in the aforementioned conventional structure, because the sucked gas is likely to flow from the communication opening at the electric motor side suction chamber to the suction opening located at the closest position, the sucked gas is liable to stay in a motor portion apart from both openings and the motor portion becomes hard to be cooled, and therefore, the motor section may be overheated. In the present invention, however, by disposing the communication path, particularly, the communication opening, and the suction passageway, particularly, the suction opening, at positions opposite to each other, the sucked gas flowing from the communication opening to the suction opening flows over a wide area without staying, the motor is properly cooled over a wide area, and occurrence of an overheating may be prevented. Further, as the result that the motor is appropriately cooled over a wide area, the available operational range of the motor can be enlarged.

Effect According to the Invention

[0019] Thus, in the hybrid compressor according to the present invention, the sucked gas for cooling can be flowed over a wide area in the electric motor side suction chamber without being stayed, the whole of the motor can be appropriately cooled, and a rise in temperature of the motor at the time of motor operation can be suppressed low. Therefore, occurrence of an inconvenience accompanying with an overheating of the motor can be avoided, and the available operational range of the motor can be enlarged.

BRIEF EXPLANATION OF THE DRAWINGS

[0020] FIG. 1 is a vertical sectional view of a conventional hybrid compressor.

[0021] FIG. 2 is a schematic vertical sectional view showing an example of a structure for cooling a motor section in the conventional hybrid compressor.

[0022] FIG. 3 is a schematic vertical sectional view showing an example of a center plate in the structure depicted in FIG. 2.

[0023] FIG. 4 is an elevational view showing an example of the disposition of communication openings and suction openings of the center plate depicted in FIG. 3.

[0024] FIG. 5 is a schematic vertical sectional view showing an example of a fixed scroll member in the structure depicted in FIG. 2.

[0025] FIG. 6 is an elevational view showing an example of the disposition of communication paths of the fixed scroll member depicted in FIG. 5.

[0026] FIG. 7 is a schematic vertical sectional view showing an example of a structure for cooling in a hybrid compressor according to an embodiment of the present invention.

[0027] FIG. 8 is an elevational view showing an example of the disposition of communication paths of a fixed scroll member in the structure depicted in FIG. 7.

[0028] FIG. 9 is an elevational view showing an example of the disposition of communication openings and suction openings of a center plate in the structure depicted in FIG. 7.

EXPLANATION OF SYMBOLS

[0029] 1: hybrid compressor
 [0030] 2: first compression mechanism
 [0031] 3: second compression mechanism

[0032] 10: fixed scroll
 [0033] 11: movable scroll
 [0034] 13: drive shaft
 [0035] 14: pulley
 [0036] 15: electromagnetic clutch
 [0037] 16: ball coupling
 [0038] 18: suction port
 [0039] 19: suction path
 [0040] 20: suction chamber
 [0041] 21: discharge hole
 [0042] 22: discharge path
 [0043] 23: discharge port
 [0044] 30: fixed scroll
 [0045] 31: movable scroll
 [0046] 33: drive shaft
 [0047] 34: ball coupling
 [0048] 35: electric motor
 [0049] 36: rotor
 [0050] 37: motor coil part (stator)
 [0051] 38: stator housing
 [0052] 39: first communication path
 [0053] 40: suction chamber
 [0054] 41: discharge hole
 [0055] 42: discharge path
 [0056] 43: fixed scroll member
 [0057] 50: power supply portion
 [0058] 51: electric motor side suction chamber
 [0059] 52: communication path
 [0060] 53: suction passageway
 [0061] 61: communication path
 [0062] 62: communication opening
 [0063] 63: suction passageway
 [0064] 64: suction opening
 [0065] 65: fixed scroll member
 [0066] 66: portion which is not provided with communication path and communication opening
 [0067] 67: center plate
 [0068] 68: suction opening
 [0069] 69: suction passageway
 [0070] 70: portion which is not provided with suction opening and suction passageway

THE BEST MODE FOR CARRYING OUT THE INVENTION

[0071] Hereinafter, desirable embodiments of the present invention will be explained referring to figures.

[0072] FIG. 7 depicts a structure of a hybrid compressor according to an embodiment of the present invention, in correspondence with FIG. 2 aforementioned. Since the structure depicted in FIGS. 1 and 2 is applied correspondingly to the basic structure of the hybrid compressor depicted in FIG. 7, the explanation will be omitted by attaching the same symbols as those attached in FIGS. 1 and 2 to the portions having substantially same structures as those shown in FIGS. 1 and 2. Hereinafter, points different from the structure shown in FIGS. 1 and 2 will be mainly explained. Where, the arrows depicted in FIG. 7 show an example of a refrigerant gas flow at the time of motor operation.

[0073] The structure depicted in FIG. 7 is different from the structure depicted in FIG. 2, in that communication paths 61 for sucking the gas to be compressed, which has been sucked from suction path 19 into suction chamber 20 of first compression mechanism 2 (in this embodiment, low-temperature refrigerant gas before compression), into electric motor side

suction chamber 51, and/or, communication openings 62 which are openings of the communication paths 61 at electric motor side suction chamber 51, and, suction passageways 63 of the refrigerant gas from electric motor side suction chamber 51 to suction chamber 40 of second compression mechanism 3, and/or, suction openings 64 which are openings of the suction passageways 63 at electric motor side suction chamber 51, are disposed at positions apart from each other in the electric motor side suction chamber 51, particularly, at positions opposite to each other.

[0074] For example, as an example of a fixed scroll member 65 in this embodiment is shown in FIG. 8 in correspondence with FIG. 6 aforementioned, communication paths 61 are provided only at the upper portion depicted in FIG. 8, and the communication paths 61 are not provided for the lower and side portions 66 depicted in FIG. 8, in which communication paths 52 have been provided in FIG. 6. Namely, in the structure for disposing communication paths 52 in FIG. 6, the communication paths 52 are abolished in these portions 66. Accompanying with this disposition of communication paths 61, communication openings 62, which are openings of the communication paths 61 at electric motor side suction chamber 51, are also provided only at the upper portion depicted in FIG. 8, and they are not provided at positions corresponding to the above-described portions 66.

[0075] Further, for example, as an example of a center plate 67 in this embodiment is shown in FIG. 9 in correspondence with FIG. 4 aforementioned, suction openings 68 and suction passageways 69 are provided only at the lower portion depicted in FIG. 9, and the suction openings 68 and suction passageways 69 are not provided for the upper portions 70 depicted in FIG. 9, in which suction openings 56 and suction passageways 53 have been provided in FIG. 4. Namely, in the structure for disposing suction openings 56 and suction passageways 53 in FIG. 4, the suction openings 56 and suction passageways 53 are abolished in these portions 70.

[0076] Thus, for electric motor side suction chamber 51, particularly the positions and/or numbers of communication openings 62 and suction openings 68 are limited, and in particular, they are located at positions opposite to each other. By this, the refrigerant gas sucked from communication openings 62 and flowing to suction openings 68 in electric motor side suction chamber 51 flows over a wide area without staying, as shown in FIG. 7.

[0077] Consequently, motor 35 can be appropriately cooled over the entire area, and a rise in temperature of the motor 35 at the time of motor operation can be suppressed low. Therefore, occurrence of the inconvenience accompanying with an overheating of the motor can be avoided, and the available operational range of the motor can be enlarged.

INDUSTRIAL APPLICATIONS OF THE INVENTION

[0078] The present invention can be applied to any hybrid compressor into which a first compression mechanism and a

second compression mechanism are integrally incorporated and the second compression mechanism of which is driven by a built-in electric motor.

1. A hybrid compressor having a first compression mechanism driven only by an external drive source, a second compression mechanism driven only by a built-in electric motor, a suction path for sucking gas to be compressed into said first compression mechanism, a communication path for sucking the gas from said first compression mechanism side into an electric motor side suction chamber, and a suction passageway for sucking the gas from said electric motor side suction chamber to said second compression mechanism side, characterized in that positions and/or number of said communication path and/or said suction passageway, and/or positions and/or number of a communication opening, which is an opening of said communication path that is opened at said electric motor side suction chamber, and/or a suction opening, which is an opening of said suction passageway that is opened at said electric motor side suction chamber and located on a side opposite to the side of said communication opening, are limited so that, with respect to at least a part of the gas sucked into said electric motor side suction chamber via said communication path, a gas flow is formed from said communication opening to said suction opening.

2. The hybrid compressor according to claim 1, wherein said communication opening is provided only at a position on one side in said electric motor side suction chamber, and said suction opening is provided only at a position on a side opposite to said one side in said electric motor side suction chamber.

3. The hybrid compressor according to claim 1, wherein said communication opening, said communication path, said suction passageway and said suction opening are provided at plurality conditions, respectively.

4. The hybrid compressor according to claim 1, wherein a center plate is provided between said electric motor side suction chamber and said second compression mechanism, and said communication opening and said suction opening are formed on said center plate.

5. The hybrid compressor according to claim 1, wherein a fixed scroll of said first compression mechanism and a fixed scroll of said second compression mechanism are integrally formed as a common fixed scroll member, and a part of said communication path is formed on said fixed scroll member.

6. The hybrid compressor according to claim 1, wherein said external drive source is a drive source for running a vehicle.

7. The hybrid compressor according to claim 1, wherein said gas to be compressed is refrigerant.

* * * * *