

G. READ & J. J. NICKOLL.  
Ships' Signals.

No. 133,385.

Patented Nov. 26, 1872.

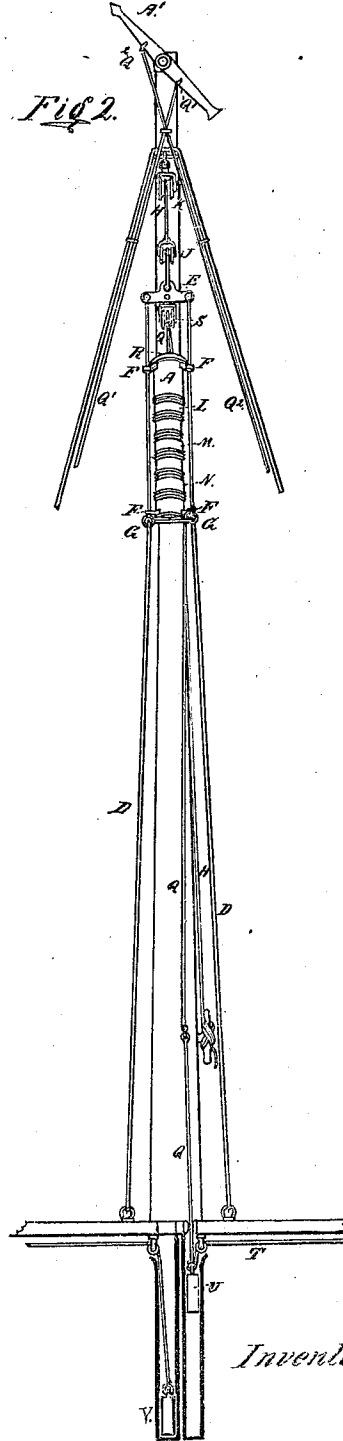
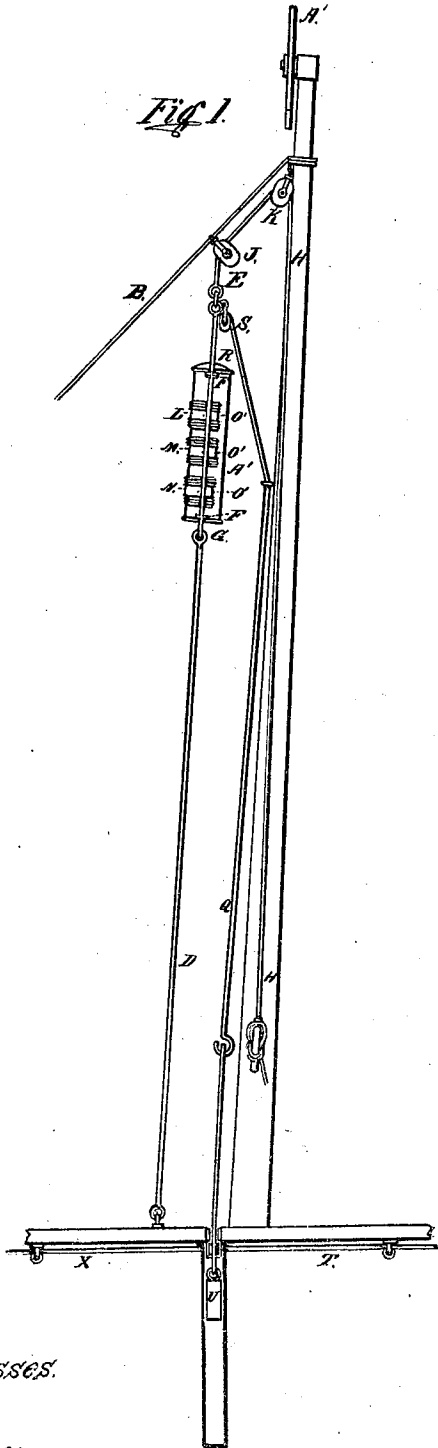

Witnesses.

Albany  
F. Finch

Inventors.

George Read  
John James Nickoll.

G. READ & J. J. NICKOLL.  
Ships' Signals.

No. 133,385.

Patented Nov. 26, 1872.

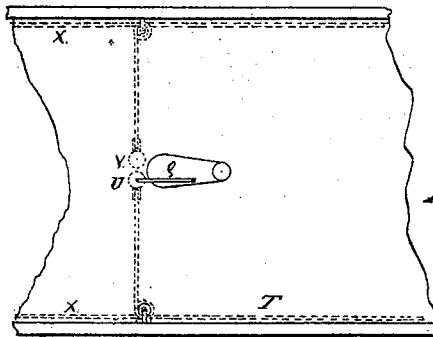
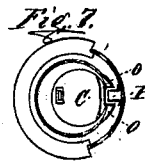
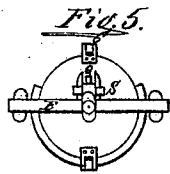
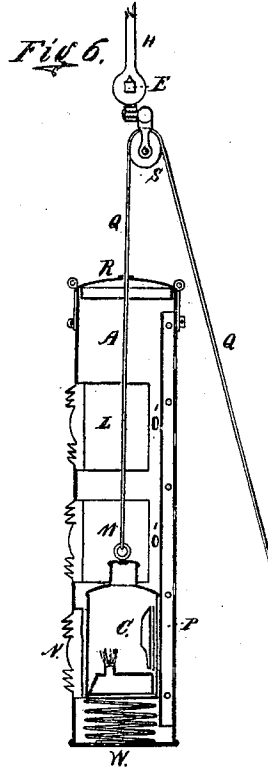
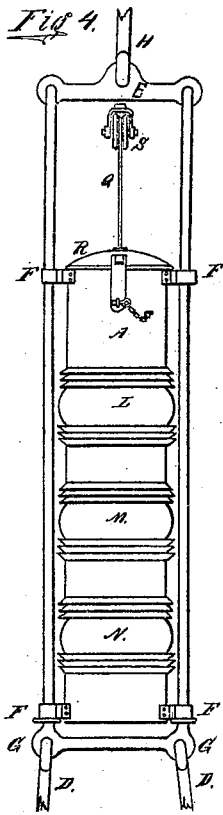
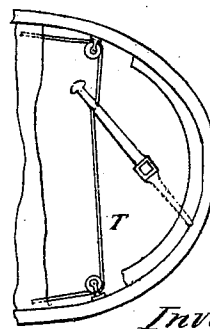

Fig. 8.



Witnesses

*H. C. Davis  
F. L. Luch*

Inventors

*George Read  
John James Nickoll*

G. READ & J. J. NICKOLL.

Ships' Signals.

No. 133,385.

Patented Nov. 26, 1872.

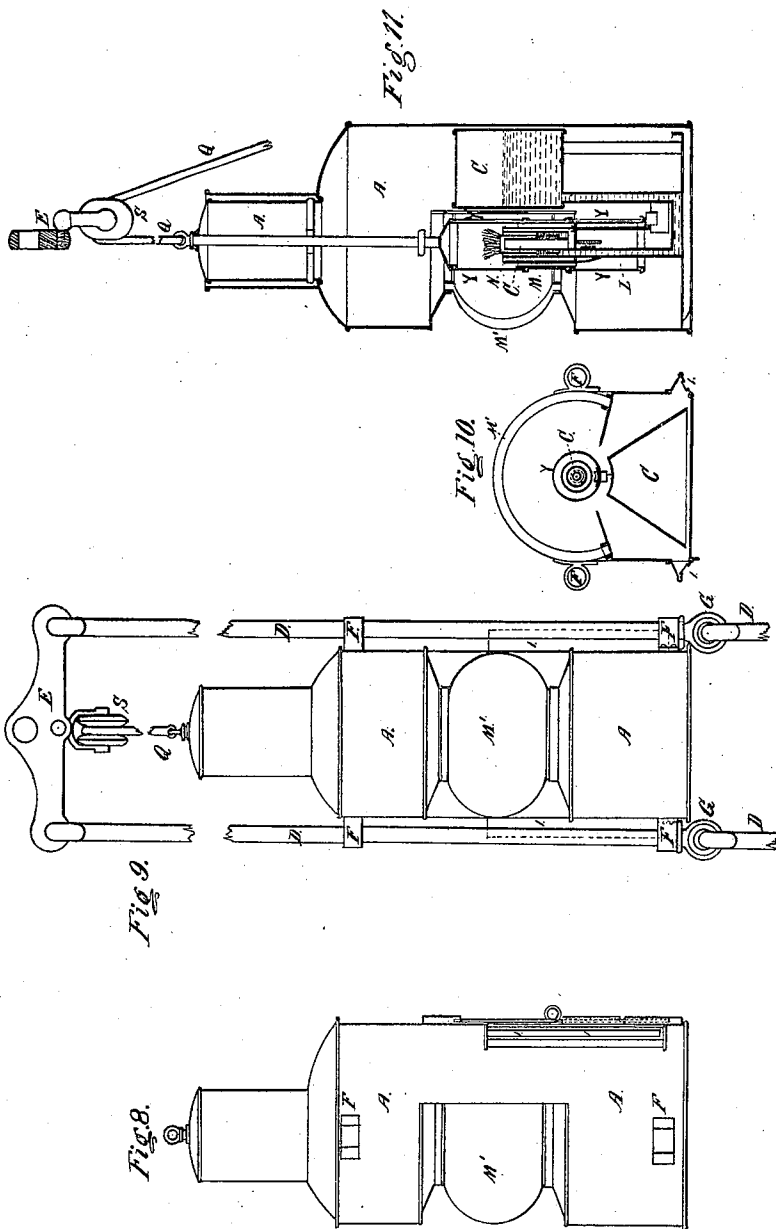

Witnesses:

*H. Sawyer  
F. Finch*

Inventors:

*George Read  
John James Nickoll*

# UNITED STATES PATENT OFFICE.

GEORGE READ, OF DEAL, AND JOHN JAMES NICKOLL, OF SOUTH HILL HOUSE, GRAVESEND, GREAT BRITAIN.

## IMPROVEMENT IN SHIP'S SIGNALS.

Specification forming part of Letters Patent No. 133,385, dated November 26, 1872.

*To all whom it may concern:*

Be it known that we, GEORGE READ, of Deal, chief officer in the coast-guard service, and JOHN JAMES NICKOLL, of South Hill House, Gravesend, both in the county of Kent and Kingdom of Great Britain, have invented "An Improved Apparatus for Signaling, Applicable to use on Ships or on Land," of which the following is a specification:

The object of our invention is to provide for public use a simple practical means whereby the position of a ship and the course she is steering may be indicated to other vessels by means of signal-lamps and semaphores carried aloft, and so constructed and connected to the tiller or rudder that the character and appearance of said signals will be automatically changed by the movement of the tiller or rudder of the ship, so as to present, for example, a white light when she is steering straight ahead, a red light when her helm is a port, and a green light when it is to the starboard. To this end the invention consists, first, in the employment of a guide-frame, a cylinder or lens box supported by the frame, and a lamp inclosed within the cylinder or lens box, the cylinder being capable of sliding in or on the frame and over the lamp, or the lamp being capable of sliding in the cylinder, and the whole being connected to the tiller or rudder by suitable means, for the purpose referred to; and, secondly, in the employment of a system of weights to take up the slack of the connecting-cords and keep them taut at all times, so that the signals will instantly respond to the movements of the helm, all as hereinafter described.

In the daytime instead of lights we employ a semaphore or yard arm, which, being operated in a similar manner from the steering apparatus, its various positions will indicate whether the ship is steering a port, right ahead, or a starboard course; and in order that our said invention may be fully understood and readily carried into effect, we will proceed to describe the drawing hereunto annexed.

Figure 1 represents a side elevation of the apparatus as placed in position on the foremast of the ship; Figs. 2 and 3, respectively, a front elevation and plan of the same; Figs. 4, 5, 6, and 7, respectively, a front elevation,

plan, vertical, and horizontal sections of the same to a larger scale.

Like letters refer to similar parts in each of these figures.

A, the signaling-cylinder, shown suspended to the stay B, and within which cylinder the lamp C is caused to slide up and down in unison with the motion of the rudder, in the manner to be hereafter described. D D, guide-lines fixed at top to a cross-piece, E, and at bottom to the deck or other convenient point of attachment. On these guide-lines the cylinder is steadied and supported by the eyes F F, which in the ordinary position of the cylinder rest on the thimbles G G or other suitable supports fixed to the guide-lines. The cylinder is hoisted into position and the guide-lines tightened by means of a line, H, one end of which is attached to the cross-piece E, and the other rove through the pulley-blocks J K, being then carried down to the foot of the mast, where it is made fast. The block J is provided with a ring, which allows it to be raised or lowered on the stay B at pleasure. In openings in the front part of the cylinder are inserted the lenses L M N, the upper one L being, say, red, the middle one M white, and the lower one N green. The said lenses are of the usual segmental form, as shown in the sectional plan, Fig. 7, in order to allow the rays of light emanating from the lamp to be visible over the requisite arc; or, if preferred, they may be made circular, so as to show a light all round. The lamp C is constructed as an ordinary ship's lamp, by preference circular in plan, and provided with reflectors suited to the arc of the lenses. A guide-groove, O, formed in it, receives a tongue or fillet, P, fitted in the cylinder to prevent the lamp turning therein. Holes for the admission of air into the cylinder, to support combustion in the lamp, may be conveniently formed in this fillet, which is shown hollow, other holes being cut in the back of the cylinder to admit air into the hollow fillet. By this means drafts of air in the cylinder or lamp may be avoided. The lamp is attached to a lanyard, Q, which passes up through the cover R of the cylinder over the pulley-block S fastened to the cross-piece E, and down the mast to near the deck, where it is attached to a line connected with

some convenient and suitable moving part of the steering apparatus. This line connected with the steering apparatus may be a single line, such as T, attached at one end to, say, the tiller, as shown, and, being led by guide-pulleys, preferably beneath the deck, into a suitable position, has at its other end a balance-weight, U. The motion of the steering apparatus in moving the rudder to one side will thus impart to the line T a movement in one direction, raising the weight U, and when the rudder is moved to the opposite side the weight will draw the line in the opposite direction. The lamp-lanyard Q, being attached to the said line or to the weight, as shown, will receive a corresponding movement. A weight, V, may also be applied to the other side of the tiller to counterbalance the weight U. It will now be understood that—the lines Q and T being connected together in such manner that when the helm is amidships the lamp C in the cylinder is suspended opposite to the white lens—any movement of the helm to the starboard or port side will depress or elevate the lamp so as to bring it opposite to the green or red lens, and thus indicate at a distance from the ship whether she is steering a starboard, right ahead, or port course; and, when desired, the position of the lamp in the cylinder may be indicated to the officer of the watch by the holes I I I in the back of the cylinder provided with colored glasses corresponding to the lenses. The line T should be attached to that part of the steering-gear that will move the lamp from the white lens to one of the colored ones before the rudder shall have altered the course of the ship to any material extent, (or, if preferred, it may be so regulated as to show the light only at the last turn of the steering-wheel either way.) The relative positions of the lamp and lenses are not altered by the further movement of the rudder in the same direction, by reason, in the one case, of the lamp coming in contact with the cover R and raising the said cylinder thereby, and, in the other case, by the lamp resting on the spring W, or on the bottom of the cylinder the lamp, lanyard Q becoming slack. By these means the lamp can never be moved beyond the lenses. The cover R of the cylinder may be removed to admit the lamp, after which it is closed and fastened by thumb-screws or staples and wedge, as shown. Instead of the single line or rope T and balance-weight U, an endless line and leading pulleys, such as X, shown in dotted lines in Fig. 3, carried round the deck in any convenient manner and position, or rods and cranked levers or other suitable mechanism, may be employed to impart motion to the lamp; and it will be seen that if preferred the lamp may be made to remain stationary, and motion only given to the cylinder by similar means to those described for moving the lamp. One modification of the apparatus by which this may be carried into effect is shown in Figs. 8, 9, 10, 11, in

which it will be seen that a cylindrical shade, Y, incloses the circular burner of the lamp C. This shade is composed of colored glasses similarly to the lenses of the cylinder before described, and is operated from the steering-gear by the line Q. In this case the lamp C remains stationary in the enveloping lantern A, which is provided with one clear or white lens, M', and, the parti-colored shade Y being moved up and down around the burner, similar effects are produced to those before described, in which the lamp is moved inside the cylinder. If it is desired not to exhibit a white light when the helm is amidships the white lens may be omitted and the cylinder or cylindrical shade left solid or opaque between the red and green lenses. Figs. 1 and 2 also show a semaphore or yard arm arranged and operated so as to indicate in the daytime the movements of the rudder. A<sup>1</sup> is the semaphore-arm centered on a pin and placed in some conspicuous position on the fore part of the ship, as on the mast. Q<sup>1</sup> Q<sup>2</sup>, lanyards attached one to each side of the center thereof; these lanyards are led down and connected to the endless line X, or to the weighted line T before described, in such manner that the motion of the rudder shall elevate, as shown, that arm of the semaphore which corresponds to the side of the ship toward which the helm is put over, and thus indicate the direction she is taking or is about to take.

Instead of applying the before-described apparatus at the mast-head, one such may be applied to each side of the ship, and, being connected with the steering-gear, will indicate in a more efficient manner than the present regulation lights the position a ship's helm may be in at any moment by so arranging the lenses that the color visible shall be that which accords with the side to which the helm is put over, and when so applying the apparatus we prefer to use a mast-head or position light, the front of which shows white and the starboard and port sides green and red, respectively, for the purpose of indicating the general direction a ship may be taking. The apparatus is also applicable to ships riding at anchor where in the helm is sometimes lashed, say to port, the cable being at sheer on port bow, thus giving to another ship a chance of anchoring in a clear berth on the starboard side.

It will be readily understood that this apparatus is applicable to a variety of purposes where signaling is required, as for example, in harbors, to indicate to a ship about to enter the course she should follow, by simply moving the lamp in the cylinder opposite to the colored lens, indicating the direction to which the ship's helm should be put over. Also, by employing a suitable notation and code corresponding to the colors and position of the lenses in the cylinder, any required messages or signals may be transmitted, whether on sea or land; and for this purpose several cylinders and lamps may be employed, with the lenses arranged and combined in any suitable

manner, the lamp being moved in the cylinder by hand or by mechanical means, as may be preferred.

We claim as our invention—

1. The guide frame or lines, the lens box or cylinder, capable of a vertical movement in or upon the said frame or lines, and the lamp, capable of a vertical movement relatively to the lens box or cylinder and to the guide-frame or lines, when combined with each other and with the tiller or rudder and connecting-lines, substantially as and for the purposes set forth.

2. The weights U V, arranged in guides and combined with the automatic signal apparatus, herein described, substantially as and for the purposes set forth.

In witness whereof we have hereunto subscribed our hands this 13th day of July, 1872.

GEORGE READ,

*Chief Officer R. N.*

JOHN JAMES NICKOLL.

Witnesses:

H. C. DAVEY,

F. FINCH.