



(51) International Patent Classification:

<i>F16M 11/04</i> (2006.01)	<i>F16M 13/02</i> (2006.01)
<i>A45F 5/00</i> (2006.01)	<i>F16M 13/04</i> (2006.01)
<i>A45F 5/02</i> (2006.01)	<i>G06F 1/16</i> (2006.01)
<i>H04B 1/3888</i> (2015.01)	<i>H04M 1/04</i> (2006.01)
<i>H04M 1/02</i> (2006.01)	<i>A45F 5/10</i> (2006.01)
<i>A44B 99/00</i> (2010.01)	<i>F16M 11/16</i> (2006.01)
<i>F16M 11/38</i> (2006.01)	<i>F16M 11/20</i> (2006.01)
<i>F16M 13/00</i> (2006.01)	

(21) International Application Number:

PCT/US2019/051394

(22) International Filing Date:

17 September 2019 (17.09.2019)

(25) Filing Language:

English

(26) Publication Language:

English

(30) Priority Data:

62/754,760 02 November 2018 (02.11.2018) US

(71) Applicant: **POPSOCKETS LLC** [US/US]; 5757 Central Avenue, Boulder, CO 80301 (US).

(72) Inventor: **CHIANG, Randy Yang**; c/o PopSockets LLC, 5757 Central Avenue, Boulder, CO 80301 (US).

(74) Agent: **FURMANEK, Michael P.**; Marshall, Gerstein & Borun LLP, 233 S. Wacker Drive, 6300 Willis Tower, Chicago, IL 60606-6357 (US).

(81) Designated States (unless otherwise indicated, for every kind of national protection available): AE, AG, AL, AM, AO, AT, AU, AZ, BA, BB, BG, BH, BN, BR, BW, BY, BZ, CA, CH, CL, CN, CO, CR, CU, CZ, DE, DJ, DK, DM, DO, DZ, EC, EE, EG, ES, FI, GB, GD, GE, GH, GM, GT, HN, HR, HU, ID, IL, IN, IR, IS, JO, JP, KE, KG, KH, KN, KP, KR, KW, KZ, LA, LC, LK, LR, LS, LU, LY, MA, MD, ME, MG, MK, MN, MW, MX, MY, MZ, NA, NG, NI, NO, NZ, OM, PA, PE, PG, PH, PL, PT, QA, RO, RS, RU, RW, SA, SC, SD, SE, SG, SK, SL, SM, ST, SV, SY, TH, TJ, TM, TN, TR, TT, TZ, UA, UG, US, UZ, VC, VN, ZA, ZM, ZW.

(84) Designated States (unless otherwise indicated, for every kind of regional protection available): ARIPO (BW, GH, GM, KE, LR, LS, MW, MZ, NA, RW, SD, SL, ST, SZ, TZ, UG, ZM, ZW), Eurasian (AM, AZ, BY, KG, KZ, RU, TJ, TM), European (AL, AT, BE, BG, CH, CY, CZ, DE, DK, EE, ES, FI, FR, GB, GR, HR, HU, IE, IS, IT, LT, LU, LV, MC, MK, MT, NL, NO, PL, PT, RO, RS, SE, SI, SK, SM, TR), OAPI (BF, BJ, CF, CG, CI, CM, GA, GN, GQ, GW, KM, ML, MR, NE, SN, TD, TG).

(54) Title: ACCESSORY FOR A PORTABLE ELECTRONIC DEVICE

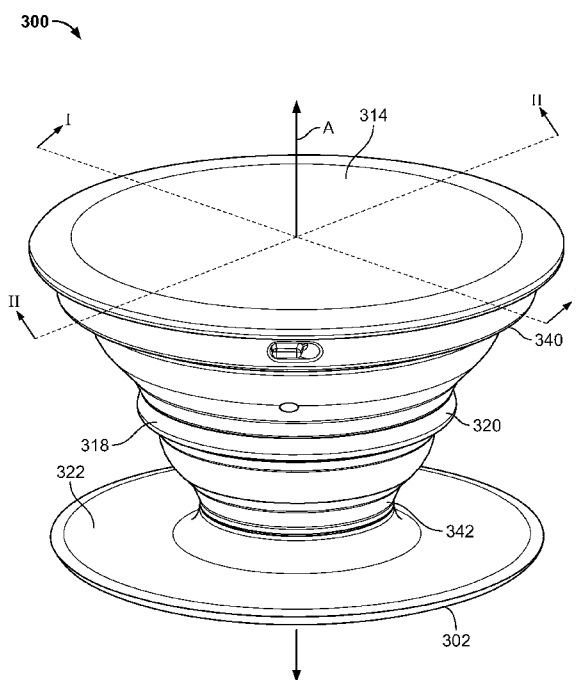

FIG. 5

(57) Abstract: An accessory for a portable electronic device includes a button having a top side and a bottom side that carries a first release component, a platform having a top side and a bottom side, the top side carrying a second release component, and a coupling mechanism operably coupled to the platform. The coupling mechanism is in the form of a magnetic member. The first release component selectively secures to the second release component to secure the button to the platform. The coupling mechanism is adapted to magnetically couple to an object.



WO 2020/091903 A1

Published:

— *with international search report (Art. 21(3))*

ACCESSORY FOR A PORTABLE ELECTRONIC DEVICE

CROSS-REFERENCE TO RELATED APPLICATION

[0001] Priority is claimed to United States Provisional Patent Application No. 62/754,760, filed November 2, 2018, the entire contents of which are hereby incorporated by reference.

FIELD OF THE DISCLOSURE

[0002] The present disclosure generally relates to an accessory device and, more particularly, to accessory devices for expandable devices that can be attached to a portable electronic device or a case for a portable electronic device and used as grips, stands, or for other purposes.

BACKGROUND

[0003] Portable electronic devices, such as MP3 players and smart phones, are often housed in protective covers or cases in order to protect the device from damage, provide a grip for handling the device, and/or provide a stand for propping the device on a surface. Such cases increase the effective size of the device. Expandable devices and accessories, which may be attached directly to the device or to the case protecting the device, are used for a variety of functions, including propping the device on a surface and providing an expandable grip for handling the device. The expandable devices have decorative buttons, which may display logos, decals, symbols, or other artistic renderings. In some cases, a user may wish to interchange a button to provide a different visual effect.

SUMMARY

[0004] In accordance with one aspect, an accessory for a portable electronic device includes a button having a top side and a bottom side that carries a first release component, a platform having a top side and a bottom side, the top side carrying a second release component, and a coupling mechanism operably coupled to the platform. The coupling mechanism is in the form of a magnetic member. The first release component selectively secures to the second release component to secure the button to the platform. The coupling mechanism is adapted to magnetically couple to an object, which, in some examples, may be an appliance.

[0005] In some approaches, the magnetic member is flush-mounted to the bottom side of the platform. In other approaches, the magnetic member protrudes outwardly from the bottom side

of the platform. In any of these approaches, the magnetic member may be formed integrally with the platform.

[0006] In some examples, the accessory further includes an expandable body including a first end, a second end, and a longitudinal axis. The expandable body is operably coupled to at least one of the platform or the button and is movable between an expanded configuration and a collapsed configuration to selectively move the button between the expanded configuration and the collapsed configuration. In some of these approaches, upon decoupling the first release component from the second release component, the expandable body remains coupled to the button. In other approaches, upon decoupling the first release component from the second release component, the expandable body remains coupled to the platform.

[0007] In accordance with a second aspect, an approach for operating an accessory for a portable electronic device includes securing a platform of the accessory to an object using a coupling mechanism and securing a button of the accessory to the platform using a release component. The coupling mechanism is in the form of a magnetic member. The release component includes a first portion operably secured to the platform and a second portion operably secured to the button to releasably secure the button to the platform.

BRIEF DESCRIPTION OF THE DRAWINGS

[0008] The above needs are at least partially met through provision of the accessory for a portable electronic device described in the following detailed description, particularly when studied in conjunction with the drawings, wherein:

[0009] Fig. 1 illustrates a perspective view of an example accessory in accordance with various embodiments;

[0010] Fig. 2 illustrates a cross-sectional side elevation view of the accessory of Fig. 1 in accordance with various embodiments;

[0011] Fig. 3 illustrates a perspective view of the accessory of Figs. 1 and 2 coupled to an object in accordance with various embodiments;

[0012] Fig. 4 illustrates a perspective view of a second example accessory in accordance with various embodiments;

[0013] Fig. 5 illustrates an isometric view of a third example accessory device in accordance with various embodiments;

[0014] Fig. 6 is an exploded view of the accessory device of Fig. 5, including an example button, an example body including an example disk, an example hub, and an example platform in accordance with various embodiments;

[0015] Fig. 7 is a front, cross-sectional view of the accessory device taken at I-I of Fig. 5 in accordance with various embodiments;

[0016] Fig. 8 is a side, cross-sectional view of the accessory device taken at II-II of Fig. 5 in accordance with various embodiments;

[0017] Fig. 9 is a front, cross-sectional view of the accessory device of Fig. 5 in a collapsed configuration in accordance with various embodiments;

[0018] Fig. 10 is a bottom view of the button of Fig. 5 in accordance with various embodiments;

[0019] Fig. 11 is a top view of the connecting disk of Fig. 5 in accordance with various embodiments;

[0020] Fig. 12 is a side view of the connecting disk of Fig. 11 in accordance with various embodiments;

[0021] Fig. 13 is a isometric view of the hub of Fig. 5 in accordance with various embodiments;

[0022] Fig. 14 is a bottom view of the hub of Fig. 13 in accordance with various embodiments;

[0023] Fig. 15 is a top view of the platform of Fig. 15 in accordance with various embodiments;

[0024] Fig. 16 is a side, cross-sectional view of the platform taken at III-III of Fig. 13 in accordance with various embodiments;

[0025] Fig. 17 is a front, cross-sectional view of the platform taken at IV-IV of Fig. 13 in accordance with various embodiments;

[0026] Fig. 18 is a front, cross-sectional view of a fourth example accessory device constructed in accordance with various embodiments;

[0027] Fig. 19 is a side, cross-sectional view of the accessory device of Fig. 18 in accordance with various embodiments; and

[0028] Fig. 20 is a top view of a second example connector of the accessory device of Fig. 18 in accordance with various embodiments.

[0029] Skilled artisans will appreciate that elements in the figures are illustrated for simplicity and clarity and have not necessarily been drawn to scale. For example, the dimensions and/or relative positioning of some of the elements in the figures may be exaggerated relative to other elements to help to improve understanding of various embodiments of the present invention. Also, common but well-understood elements that are useful or necessary in a commercially feasible embodiment are often not depicted in order to facilitate a less obstructed view of these various embodiments. It will further be appreciated that certain actions and/or steps may be described or depicted in a particular order of occurrence while those skilled in the art will understand that such specificity with respect to sequence is not actually required. It will also be understood that the terms and expressions used herein have the ordinary technical meaning as is accorded to such terms and expressions by persons skilled in the technical field as set forth above except where different specific meanings have otherwise been set forth herein.

DETAILED DESCRIPTION

[0030] Generally speaking, pursuant to these various embodiments, accessory devices for use with expandable devices for portable electronics are provided. These accessory devices may be releasably mounted or coupled to an object. Generally, an expandable accessory device includes a platform, a button, and an expanding mechanism that is movable relative to the platform between a collapsed configuration and an expanded configuration. These expandable devices may be coupled to a portable electronic device (e.g., a cellular telephone, a tablet, a laptop, etc.) to provide a gripping and/or storage mechanism for a user. Some of these expandable devices are adapted to accommodate releasable buttons via a release mechanism, each of which may be adorned with different decorative buttons displaying logos, decals, symbols, and/or other artistic renderings. Accordingly, the accessory devices described herein provide for the selective coupling and display of these releasable buttons.

[0031] A first embodiment of an accessory device 100 is shown in Figs. 1-3. The accessory device 100 includes a platform 122 having a top or upper side 122a and a bottom or lower side 122b, a button 114 having a top or upper side 114a and a bottom or lower side 114b, and a collapsible and/or expandable mechanism or body 118 operably coupled to the button 114 (illustrated in a collapsed configuration in Figs. 1 and 2). The accessory device 100 further includes a coupling mechanism 102 and a releasable or locking device or mechanism 124 that allows a portion of the accessory device 100 (e.g., the body 118 and/or the button 114) to be disengaged from the platform 122. In some approaches, a portion of the platform 122 (e.g., the top surface 122a) may carry a first release component 124a, and a portion of the button 118 (e.g., the bottom surface 114b) may carry a second release component 124b.

[0032] The platform 122 may have any desired shape (e.g., an annular shape) and is preferably constructed from metal or plastic material, though other suitable materials (e.g., cardboard) can be used. The body 118 generally facilitates movement of the accessory device 100 between an expanded configuration and a collapsed configuration, and to retain the accessory device 100 in the desired configuration (expanded or collapsed) when coupled to a portable electronic device (via a separate platform; not shown). The body 118 may take the form of an outer case, enclosure, shell, deformable cover, etc., and may include a resilient member (e.g., a coil spring) that is arranged between the platform 122 and the button 114.

[0033] As previously noted, the button 114 includes the top or upper side 114a and the bottom or inner side 114b and is operably coupled to the body 118. The button 114 may have an annular shape. In other examples, however, the button 114 may have a rectangular, square, triangular, irregular, or other shape. The button 114 in this example also has an outer diameter that is larger than an outer diameter of the platform 122, though this need not be the case. Like the platform 122, the button 114 is preferably constructed from metal or plastic material, though other suitable materials can be used.

[0034] As stated, the button 114 is removable from an expandable device operably coupled to a portable electronic device, and may be selectively secured to the platform 122 of the accessory device 100 for storage and/or display purposes. The button 114 may have artistic value (e.g., the button 114 may include an artistic rendering, a logo, a symbol, text, or a decal), the button 114 may provide a grip that allows a user to slide their fingers between the bottom side 114b and the

platform 122 when the body 118 is in the expanded configuration (when, for example, the button is coupled to the portable electronic device) such that the top side 114a of the button 114 is disposed adjacent to the palm of the user's hand, and may also provide a space in which a cord, such as a cord for earphones, may be wrapped and stored around a portion of the platform 122.

[0035] Generally, the body 118 is used to move from the expanded configuration to the collapsed configuration by overcoming any biasing forces applied by resilient members. This may be accomplished by grabbing or grasping the button 114 and moving (e.g., pushing) the button 114 towards the platform 122. The accessory device 100 may include any number of retaining components to maintain the accessory device 100 in the collapsed configuration. The button 114 may be positioned in the expanded configuration by grasping or pulling the button 114 away from the platform 122 with a sufficient force to overcome the force of any retaining components used to secure the accessory device 100 in the collapsed configuration. Upon doing so, if the accessory device 100 is equipped with a resilient member or members, the button 114 will be urged towards, and maintained in, an expanded configuration.

[0036] The bottom side 114b of the button 114 includes the second release component 124b to allow the button 114 to be removed from and coupled to the platform 122 of the accessory device 100. As will be described in further detail with reference to Figs. 5-20, the first and second release components 124a, 124b may include any number of subcomponents.

[0037] The coupling mechanism 102 allows the accessory device 100 to be secured to an object 108. The coupling mechanism 102 is in the form of a magnet that is operably coupled to the platform 122 (e.g., at the bottom surface 122b thereof). In some examples, and as illustrated in Figs. 1 and 2, the coupling portion 102 is disposed on the bottom surface 122b of the platform.

[0038] In operation, the accessory device 100 may be coupled to an object (e.g., an appliance such as a refrigerator as illustrated in Fig. 3, a dishwasher, etc.) by placing the platform 122 (and thus the coupling member 102) against the object 108. Other examples of suitable objects 108 are possible. The coupling member 102 will then be coupled to the object 108 via magnetic attraction. So configured, different objects (e.g., notes, drawings, receipts, papers, etc.) may be temporarily affixed to the object 108 for display.

[0039] The button 114 may then be coupled to the platform 122 via the releasable mechanism 124. As a result, any visual depictions on the button 114 may be displayed on the object 108. It

will be appreciated that in some approaches, the button 114 may be first secured to the platform 122 via the releasable mechanism 124 prior to securing the coupling mechanism 102 to the object 108. So configured, the accessory device 100 resembles a magnetic button having interchangeable visualizations by way of different buttons.

[0040] As illustrated in Fig. 4, an alternative accessory device 200 is provided. It will be appreciated that the accessory device 200 illustrated in Fig. 4 may include similar features to the accessory device 100, and thereby elements illustrated in Fig. 4 are designated by similar reference numbers indicated on the embodiment illustrated in Figs. 1-3, increased by 100. Accordingly, these features will not be described in substantial detail. In this example, the coupling mechanism 202 is embedded within the platform 222. While the illustrated example of Fig. 4 depicts the coupling mechanism 202 being flush with the bottom side 222b of the platform 222, in some approaches, the coupling mechanism 202 may be embedded within the platform 222 but still extend outwardly from the bottom surface 222b of the platform 222. In any or all of the example devices 100, 200, the coupling mechanism 102, 202 may be integrally formed with the platform 122, 222.

[0041] The above accessory devices 100, 200 may include any number of additional features as desired to improve and/or increase its functionality. For example and as previously noted, approaches described herein may include a release mechanism to allow the body and the button to be selectively decoupled from the platform. Turning to Figs. 5-9, the third example accessory device 300 is provided in further detail. As with the accessory devices 100, 200, the accessory device 300 includes a button 314, a platform 322 that is attachable to an object or component, and a body 318 attached to the button 314. The body 318 is movable between an expanded configuration, as shown in Figs. 5-8, and a collapsed configuration, as shown in Fig. 9. A release component or locking device 324, which is hidden from view in Fig. 5 and is shown in Fig. 6, is disposed between the body 318 and the platform 322 to rotatably and releasably couple the button 314 and/or the body 318 to the platform 322. The locking device 324 is movable between an unlocked configuration, in which the body 318 is removable from the platform 322, and a locked configuration, in which the body 318 is secured to the platform 322. When the body 318 is in the expanded configuration, the body 318 may rotate freely about a longitudinal axis A relative to both the platform 322 and the locking device 324. The body 318 is configured to rotate with the locking device 324, and therefore move the locking device 324 from a locked

configuration to an unlocked configuration, for example, only when the body 318 is in the collapsed configuration. As shown in Figs. 7-9, an engaging member 330 carried by an inner surface 334 of the button 314 is configured to engage with a mating surface 338 of the locking device 324 when the device 300 is in the collapsed configuration. When the button 314 and body 318 rotate about the longitudinal axis A in the collapsed configuration, the engaging member 330 of the button 314 engages the locking device 324 such that the locking device 324 is rotatable relative to the platform 322 between an unlocked configuration, in which the body 318 is removable from the platform 322, and a locked configuration, in which the body 318 is secured to the platform 322. The locking device 324 also rotates about the axis A relative to the platform 322 from the locked configuration to the unlocked configuration.

[0042] As shown in Fig. 6, the locking device 324 includes a hub 326 and a connecting disk 328 rotatably connected to the body 318. In the locked configuration, the body 318 is rotatable relative to the locking device 324 and therefore rotatably coupled to the platform 322 by way of the locking device 324. The platform 322 has the coupling mechanism 302 that assists in attaching the platform 322 to an object. The coupling mechanism 302 secures the platform 322 relative to the device and may facilitate unlocking and locking the locking device 324. The hub 326, the connecting disk 328, the button 314, the body 318, and the platform 322 are aligned relative to the longitudinal axis A when the accessory device 300 is in the locked configuration.

[0043] The body 318 can include an accordion-like structure 318 having a collapsible wall 320. The body 318 is movable between the expanded configuration, as shown in Figs. 5-8, and collapsed configuration, as shown in Fig. 9. The body 318 is symmetrical about the longitudinal axis A, and includes a first end 340 distal to the platform 322 and a second end 342 proximate to the platform 322. When the button 314 is attached to the first end 340 of the body 318, the wall 320 of the body 318 and the button 314 define a chamber 356. The body 318 includes an aperture 358 formed in the second end 342 of the body 318 such that the locking device 324 may be partially disposed both internally and externally relative to the body 318. At the second end 342 of the body 318, the chamber 356 has a volume sized to receive the connecting disk 328. The body 318 can be made of a flexible material, such as polyester-based thermoplastic polyurethane elastomer, that may be formed by injection molding, thermoforming, or compression molding, or may be any equivalently functional material suitable for its intended purpose.

[0044] As illustrated in Figs. 7 through 9, the connecting disk 328 of the locking device 324 carried by the second end 342 of the body 318 and is disposed in the chamber 356 of the body 318 adjacent to the second end 342. In this configuration, the mating surface 338 of the connecting disk 328 faces the inner surface 334 of the button 314, and a second mating surface 360 extends through the aperture 358 of the second end 342 of the body 318 for coupling to the hub 326. The connecting disk 328 is disposed within the body 318 and is rotatable relative to the body 318. The connecting disk 328 rotates with the body 318 when the button 314 is attached to the first end 340 of the body 318 and engages with the first mating surface 338 of the connecting disk 328.

[0045] The engaging member 330 of the button 314 is particularly suited to connect with the mating surface 338 of the connecting disk 328. As such, locking device 324 of the device 300 is beneficially constructed so that the body 318 does not easily detach from the platform 322 when the device 300 is in use. The button 314 of the device 300 acts as a key to unlock or lock the body 318 from or to the platform 322 when the button 314 engages the locking device 324. In some examples where the locking device 324 is disposed below the body (as opposed to the button), the body acts as a key to unlock or lock the body from or to the platform.

[0046] As shown in Fig. 9, the engaging member 330 of the button 314 and the first mating surface 338 of the locking device 324 are arranged so that the engaging member 330 and the first mating surface 338 interlock (e.g., mesh, overlap, engage, mate, couple) when the inner surface 334 of the button 314 is adjacent to the mating surface 338. The inner surface 334 of the button 314 is shown in greater detail in Fig. 10. The engaging member 330 includes a plurality of protrusions 344 (e.g., teeth, ribs, studs, pegs, etc.) separated by a plurality of spaces 348 (e.g., grooves, notches, dimples, etc.), which may be arranged in a predetermined pattern or configuration that corresponds to the mating surface 338 of the connecting disk 328. In this example, the engaging member 330 includes a plurality protruding teeth 344 evenly spaced by the plurality of openings or grooves 348 in the shape of a ring. The engaging member 330 is disposed about the longitudinal axis A, and is symmetrical such that the button 314 may easily mesh with the first mating surface 338 of the connecting disk 328.

[0047] Fig. 11 illustrates the mating surface 338 of the connecting disk 328 is arranged in a pattern of protruding teeth 352 (e.g., protrusions, ribs, studs, pegs, etc.), which are evenly spaced

by a plurality of grooves 354 (e.g., spaces, notches, dimples, etc.). The first mating surface 338 is symmetrical about the longitudinal axis A such that the button 314 may easily mesh with the first mating surface 338 of the connecting disk 328. Briefly returning to Figs. 7-9, the plurality of protrusions 352 of the connecting disk 328 are aligned, and sized to fit, within the spaces 348 of the engaging member 330 of the button 314. Likewise, the plurality of grooves 354 are aligned, and sized to receive, the plurality of protrusions 344 of the button 314. Thus, when the body 318 is in the collapsed configuration, the plurality of protrusions 344, 352 of the button 314 and the mating surface 338 of the locking device 324 are interlocked and positioned to engage when the button 314 is rotated about the longitudinal axis A. In another example, the mating surface 338 and the engaging member 330 interlock or otherwise engage via an alternative locking configuration.

[0048] In Fig. 12, the second mating surface 360 of the connecting disk 328 is shown. The second mating surface 360 includes a flat area 362, a protruding portion 363 surrounded by the flat area 362 and extending axially away from the flat area 362 of the disk 328. The flat area 362 is configured to lay flat against an interior surface of the second end 342 of the body 318 and the protruding portion 363 is configured to at least partially extend through the aperture 358 of the body 318. The flat area 362 includes a smooth surface to reduce friction between the disk 328 and the body 318 such that the connecting disk 328 is free to rotate relative to the body 318 when the disk 328 is disposed within the chamber 356. A distal end 364 of the protruding portion 363 includes a plurality of angled tips. The angled tips 364 may be configured to flex, bend, or otherwise deform to mate with the hub 326. Once the protruding portion 363 engages the hub 326, the hub 326 and the connecting disk 328 may be fixed (e.g., welded, fused, etc.) together to move as a unitary locking device 324. Alternatively, the hub 326 and connecting disk 328 can be integrally formed. Unlike the flat area 362, the distal end 364 may be a textured material configured to frictionally engage with the hub 326 so that the connecting disk 328 rotates the hub 326 when the disk 328 and hub 326 are engaged.

[0049] In Figs. 13 and 14, the hub 326 is shown in greater detail. The hub 326 includes a body 365 and first and second radial wings 366 and 368 that extend outwardly from the body 365. The wings 366 and 368 are disposed on opposing sides of the body 365, and may be a resilient material such that the wings 366 and 368 may deform (e.g., bend, flex) when the wings 366 and 368 engage the platform 322. The body 365 includes a first surface 370 and a second surface 372

opposite the first surface 370. The first surface 370 is configured to mate with the second mating surface 360 of the connecting disk 328. More particularly, an opening 371 formed in the first surface 370 is sized and shaped to receive the protruding portion 363 of the second mating surface 360 of the connecting disk 328. As shown in Fig. 14, the hub 326 includes first and second curved notches or ramps 373, 374 formed in the second surface 372 to facilitate disengagement between the platform 322 and the hub 326 when the locking device 324 rotates relative to the platform 322. Specifically, the notches 373, 374 are formed to slide against protrusions 376, 378 extending from the platform 322 when the locking device 324 rotates a quarter turn (i.e., 90 degrees) about the longitudinal axis A. First and second detents 384, 386 are formed in the second surface 372 of the hub 326 and are shaped to engage with first and second protrusions 376, 378 of the platform 322 when the locking device 324 is in the locked configuration. In another example, the second surface 372 of the body 365 may have only one notch 373 or 374 or no notches. In the case where the hub 326 provide only one notch 373, the portion of the second surface 372 opposite disposed from the notch 373 may be flat or coplanar with the second surface 372. This configuration may facilitate removal of the body 318 from the platform 322. For example, as the locking device 324 is rotated out of locking engagement with the platform 322, the protrusion 376 or 378 of the platform 394 may bias the second surface 372 of the hub 326 upward and away from the platform 322.

[0050] The hub 326 and the platform 322 are arranged to rotatably couple to lock the body 318 to the platform 322. The first and second wings 366 and 368 are deformable such that they may deflect from their original position when the wings 366 and 368 engage first and second shelves 380, 382 of the platform 322 as the locking device 324 moves from the unlocked configuration to the locked configuration. The detents 384, 386 formed in the second surface 372 of the hub 326 are configured to engage with the platform 322 in the locked configuration. Specifically, each detent 384, 386 is partially formed in one of the two wings 366, 368. It will be appreciated that the second shelf 382 is substantially similar to the first shelf 380 and the wing 368 is substantially similar to the wing 366, such that any details of the first shelf 380 and the first wing 366 discussed below apply equally to the second shelf 382 and the second wing 368, respectively. In the illustrated accessory device 300, the locking device 324 includes two wings 366 and 368 and the platform 322 includes two shelves 380 and 382 corresponding to the wings 366 and 368 of the locking member 324. However, in another example device, the locking

device 324 may have one wing or more than two wings, and the platform 322 may have the same number of corresponding shelves. Likewise, the platform 322 includes two protrusions 376, 378 and the hub 326 includes two detents 384, 386 corresponding to the protrusions 376, 378.

However, in another example device, the hub 326 may include one detent or more than two detents, and the platform may have the same number of corresponding protrusions. The hub 326 is preferably made of a durable plastic, such as polyethylene, or a harder plastic, such as polycarbonate, that may be formed by injection molding, thermoforming, or compression molding, but may instead be formed of any other suitable and durable material including thermoplastic polyurethane, metal, fiberglass, or any combination of these materials, or any equivalently functional materials suitable for its intended purpose.

[0051] As shown in Figs. 7-9, the hub 326 is coupled to the platform 322 when the locking device is in the locked configuration. The platform 322 includes an outer surface 387 and a collar 388 extending away from the surface 387. The collar 388 defines a cavity 390. The second shelf 382 oppositely disposed from the first shelf 380 is configured to slidably receive one of the wings 366 and 368 of the hub 326. The shelves 380 and 382 are configured to engage one of the wings 366 and 368 of the locking member 324 when the locking member 324 is in the locked configuration. A surface of each shelf 380 and 382 inhibits axial movement of the locking device 324 relative to the platform 322 when the locking device 324 is in the locked configuration. The first and second wings 366 and 368 move out of engagement with the shelves 380 and 382 when the hub 326 is rotated.

[0052] As illustrated in Figs. 15 through 17, the first exemplary platform 322 includes the first shelf 380 extending radially inwardly from the collar 388 and into a cavity 390 formed in the platform 322. At least a portion of the locking device 324 is adapted to be removably disposed in the cavity of the platform 322 for releasably coupling the body 318 to the platform 322. The cavity 390 is partially defined by a non-circular opening 392, as shown in Fig. 15, and is shaped to receive the first and second wings 366 and 368 of the hub 326. In particular, the opening 392 is defined by first and second opposing shelves 380, 382, and an interior wall 3100 of the collar 388. The platform 322 also includes a base 394 that is recessed from the collar 388 and defines a lower boundary of the cavity 390 of the platform 322. The base 394 is connected to the inner wall 3100 of the platform 322 such that the base 394 may be co-planar with the mounting surface 339 of the platform 322, as shown in Fig. 16. The base 394 also includes first and second

protrusions 376, 378 extending axially into the cavity 390 and spaced radially inwardly relative to the shelves 380, 382, respectively. The base 394 is connected to the inner wall 3100 at opposing ends, which are 90 degrees offset from the first and second shelves 380, 382. Above the opposing ends of the base 394, the collar 388 defines a radially recessed inner wall 3100, providing a clearance for the hub 326. So configured, the radial wings 366, 368 of the hub 328 may slide into the opening 392 until the radial wings 366, 368 are beneath a reference plane on which the shelves 380, 382 are disposed. The base 394 is disconnected from the inner wall 3100 directly below the first and second shelves 380, 382 such that the base 394 may flex downward relative to the shelves 380, 382 when the second surface 372 of the hub 326 engages the base 394.

[0053] As shown in Figs. 16 and 17, the first shelf 380 of the platform 322 includes a first surface 3104 that faces the second end 342 of the body 318, and a second surface 3108 that engages with one of the first and second wings 366 and 368 of the locking member 324 when the locking member 324 moves from the unlocked configuration to the locked configuration. The platform 322 is preferably made of a durable plastic, such as polyethylene, or a harder plastic, such as polycarbonate, that may be formed by injection molding, thermoforming, or compression molding, but may instead be formed of any other suitable and durable material including thermoplastic polyurethane, metal, fiberglass, or any combination of these materials, or any equivalently functional materials suitable for its intended purpose.

[0054] To couple the locking member 324 to the platform 322, the hub 326 is disposed through the opening 392 and into the cavity 390 of the platform 322 such that the locking member 324 is at least partially disposed below first and second shelves 380, 382. The locking member 324 is rotated (e.g., 90 degrees) in either the clockwise or counterclockwise direction about the longitudinal axis A. As the locking member 324 is rotated, the first wing 366 of the hub 326 of the locking member 324 slides against the shelf 380 of the platform 322 until the protrusion 376 of the base 394 snaps into the detent 384 of the second surface 372 of the hub 326. Additionally, the hub 326 may deflect or displace the base 394 until the protrusion 376 and the detent 384 are engaged. The base 394 may be a resilient material such that the base 394 may deform (e.g., bend, flex) when engaged by the hub 326. In one example, the base 394 may bend or flex along a flexible hinge formed in the base 394 extending between opposing sides of the inner wall 3100 (i.e., where the base 394 connects to the platform 322). It will be appreciated that

the second shelf 382 is substantially similar to the first shelf 380, the second wing 368 is substantially similar to the first wing 366, the second detent 386 is substantially similar to the first detent 384, and the second protrusion 378 is substantially similar to the first protrusion 376, such that any details of the first shelf 380, first wing 366, first detent 384, and the first protrusion 376 discussed above apply equally to the second shelf 382, the second wing 368, the second detent 386, and the second protrusion 378, respectively.

[0055] The mating relationships between the button 314 and the connecting disk 328, the connecting disk 328 and the hub 326, and the hub 326 and the platform 322 may be configured to provide any number of different mating engagements. For example, the hub 326 may include one or more protrusions extending from its second surface 372 to couple to one or more detents formed in the base 394 of the platform 322. In another example, the second mating surface 360 of the connecting disk 328 may not extend through the aperture 358 formed in the second end 342 of the body 318, but instead, the first surface 370 of the hub 326 may include a portion that extends into the aperture 358 of the body 318 to couple with the second mating surface 360 of the connecting disk 322. Non-limiting examples of the configuration or mating relationship between the locking member 324 and the platform 322 and/or other components of the device 300 are disclosed in U.S. Appl. No. 15/864,402, filed January 8, 2018, U.S. Appl. No. 15/864,509, filed January 8, 2018, and U.S. Appl. No. 15/993,458, filed May 30, 2018, the entire disclosures of which are incorporated herein by reference.

[0056] The accessory device 300 may be moved from the locked configuration to the unlocked configuration by overcoming the frictional forces between the mating surfaces of the locking device 324 and the platform 322. Generally speaking, a user of the accessory device 300 may rotate the locking device 24 from the locked configuration to the unlocked configuration by collapsing the expandable device 310 such that the button 314 engages with the connecting disk 328 of the locking device 324, and then by grabbing or grasping the button 314 or body 318 and moving, e.g., rotating or twisting, the button 314 or body 318 a quarter turn (i.e., 90 degrees) in either the clockwise or counterclockwise direction about the longitudinal axis A. The button 314 engages with the locking device 324 to rotate the locking device 324 with the button 314 and body 318. In turn, the connecting disk 328 transfers the rotational motion from the button 314 to rotate the hub 326 of the locking device 324 out of engagement with the platform 322. Once the locking member 324 is in the unlocked configuration, the user may pull the body 318 away and

out of the cavity 390 and through the opening 392 of the platform 322 to lock the body 318 to the platform 322.

[0057] The device 300 may be assembled by connecting the connecting disk 328 to the second end 342 of the body 318 by disposing the connecting disk 328 into the chamber 356 of the body 318. The second mating surface 360 is coupled to the first surface 370 of the hub 326 such that the hub 326 and the connecting disk 328 form a unitary locking device 324. The body 318 may be coupled to the platform 322 by disposing the hub 326 into the cavity 390 of the platform 322.

[0058] Figs. 19 and 20 illustrate a fourth example device 400 constructed in accordance with the teachings of the present disclosure. The fourth example device 400 is similar to the device 300 of Figs. 5-9. Thus, for ease of reference, and to the extent possible, the same or similar components of the device 400 will retain the same reference numbers as outlined above with respect to the devices 100, 200, 300, although the reference numbers will be increased by a multiple of 100.

[0059] A button 414 of the fourth device 400 includes an engaging member 430 having a non-circular cross-sectional shape. The engaging member 430 includes a plurality of sides 431 configured to engage with a corresponding opening 448 or indentation formed in a first mating surface 438 of a locking device 424. As shown in Fig. 20, a connecting disk 428 of the locking device 424 includes the first mating surface 438 having a non-circular shape sized to receive the engaging member 430 of the button 414 when the device 410 is in a collapsed configuration. A body 418, a platform 422, and a hub 426 may be substantially similar to the body 318, platform 322, and hub 326 of the third device 300 previously described with reference to Figs. 5-17. The mating surface 438 of the locking device 424 and the engaging member 430 of the button 414 may be any number of shapes and structures that facilitate engagement between the locking device 424 and the button 414.

[0060] In some instances, the expandable grip accessory of the current disclosure may be in the form of a commercially available grip and stand product such as that available on www.popsockets.com. For example, U.S. Patent No. 8,560,031, filed on February 23, 2012; U.S. Patent No. 9,970,589, filed on November 9, 2017; U.S. Appl. No. 15/615,900, filed on June 7, 2017; U.S. Appl. No. 15/679,934, filed on August 17, 2017; U.S. Appl. No. 15/803,410, filed on November 3, 2017; U.S. Appl. No. 15/808,076, filed on November 9, 2017; U.S. Appl. No.

15/864,402, filed on January 8, 2018; U.S. Appl. No. 15/864,509, filed on January 8, 2018; U.S. Appl. No. 15/906,920, filed on February 27, 2018; U.S. Appl. No. 15/922,601, filed on March 15, 2018; U.S. Appl. No. 15/952,025, filed on April 12, 2018; U.S. Appl. No. 15/993,458, filed on May 30, 2018; and U.S. Appl. No. 16/001,723, filed on June 6, 2018 each describe suitable expandable grip and stand product, which also incorporate collapsible mechanisms, the entirety of each being hereby incorporated by reference.

[0061] Those skilled in the art will recognize that a wide variety of modifications, alterations, and combinations can be made with respect to the above described embodiments without departing from the scope of the invention, and that such modifications, alterations, and combinations are to be viewed as being within the ambit of the inventive concept.

[0062] The patent claims at the end of this patent application are not intended to be construed under 35 U.S.C. § 112(f) unless traditional means-plus-function language is expressly recited, such as “means for” or “step for” language being explicitly recited in the claim(s).

What is Claimed is:

1. An accessory for a portable electronic device, the accessory comprising:
a button having a top side and a bottom side, the bottom side carrying a first release component;
a platform having a top side and a bottom side, the top side of the platform carrying a second release component; and
a coupling mechanism operably coupled to the platform, the coupling mechanism comprising a magnetic member;
wherein the first release component selectively secures to the second release component to secure the button to the platform, and wherein the coupling mechanism is adapted to magnetically couple to an object.
2. The accessory of claim 1, wherein the magnetic member is flush-mounted to the bottom side of the platform.
3. The accessory of claim 1, wherein the magnetic member protrudes outwardly from the bottom side of the platform.
4. The accessory of any one of claims 1-3, wherein the magnetic member is formed integrally with the platform.
5. The accessory of any one of claims 1-4, further comprising an expandable body including a first end, a second end, and a longitudinal axis, the expandable body being operably coupled to at least one of the platform or the button, the body being movable between an expanded configuration and a collapsed configuration to selectively move the button between the expanded configuration and the collapsed configuration.
6. The accessory of claim 5, wherein upon decoupling the first release component from the second release component, the expandable body remains coupled to the button.

7. The accessory of claim 5, wherein upon decoupling the first release component from the second release component, the expandable body remains coupled to the platform.

8. The accessory of any one of claims 1-7, wherein the object comprises an appliance.

9. A method of operating an accessory for a portable electronic device, the method comprising:

securing a platform of the accessory to an object via a coupling mechanism;
securing a button of the accessory to the platform via a release component;
wherein the coupling mechanism comprises a magnetic member, and the release component comprises a first portion operably secured to the platform and a second portion operably secured to the button to releasably secure the button to the platform.

10. The method of claim 9, wherein the coupling mechanism is flush-mounted to a bottom side of the platform.

11. The method of claim 9, wherein the coupling mechanism protrudes outwardly from a bottom side of the platform.

12. The method of any one of claims 1-11, further comprising coupling an expandable body to at least one of the platform or the button, the expandable body including a first end, a second end, and a longitudinal axis, the expandable body being movable between an expanded configuration and a collapsed configuration to selectively move the button between the expanded configuration and the collapsed configuration.

13. The method of claim 12, further comprising decoupling the button from the platform, wherein upon decoupling the button from the platform, the expandable body remains coupled to the button.

14. The method of claim 12, further comprising decoupling the button from the platform, wherein upon decoupling the button from the platform, the expandable body remains coupled to the platform.

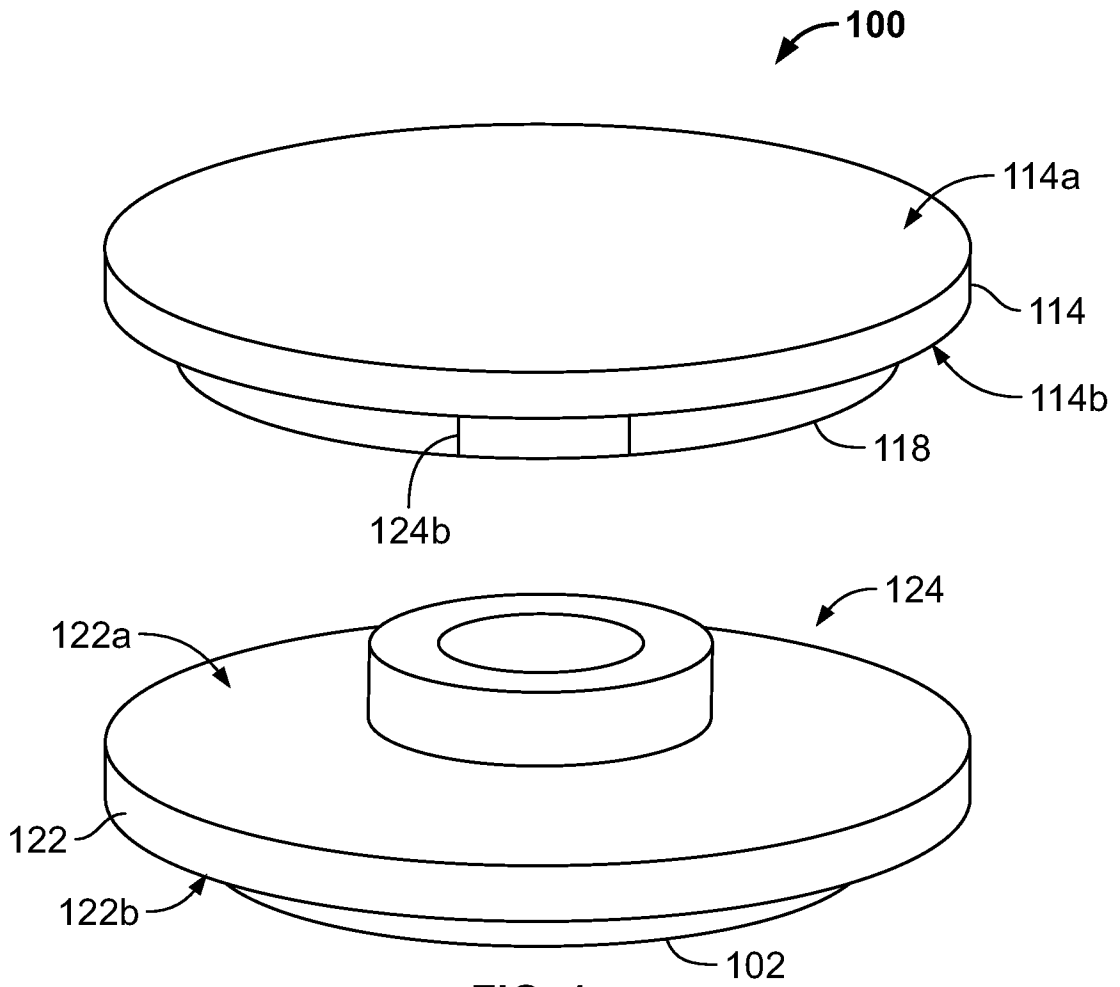

FIG. 1

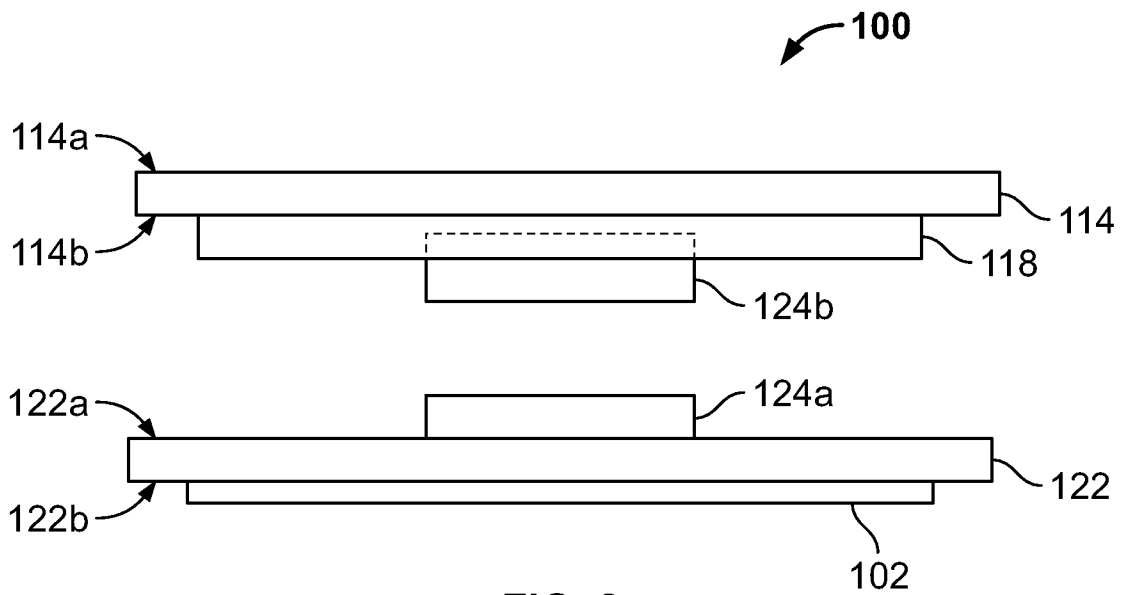

FIG. 2

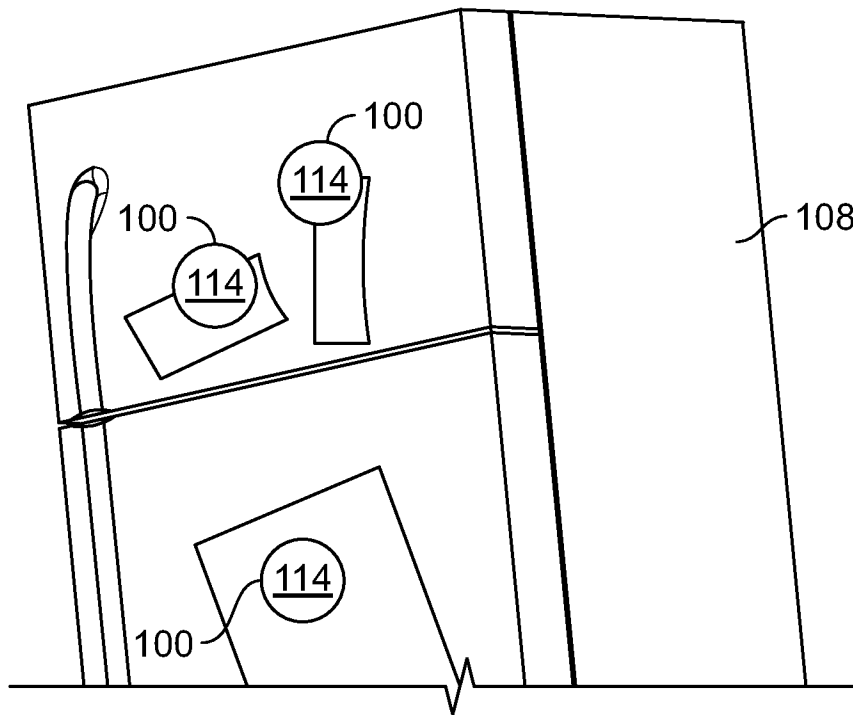

FIG. 3

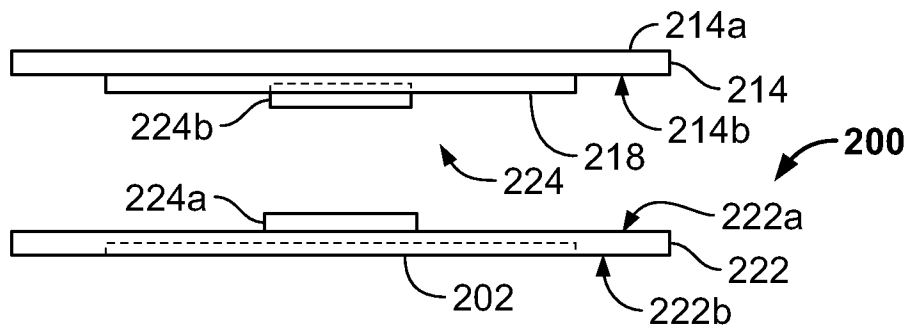

FIG. 4

3/11

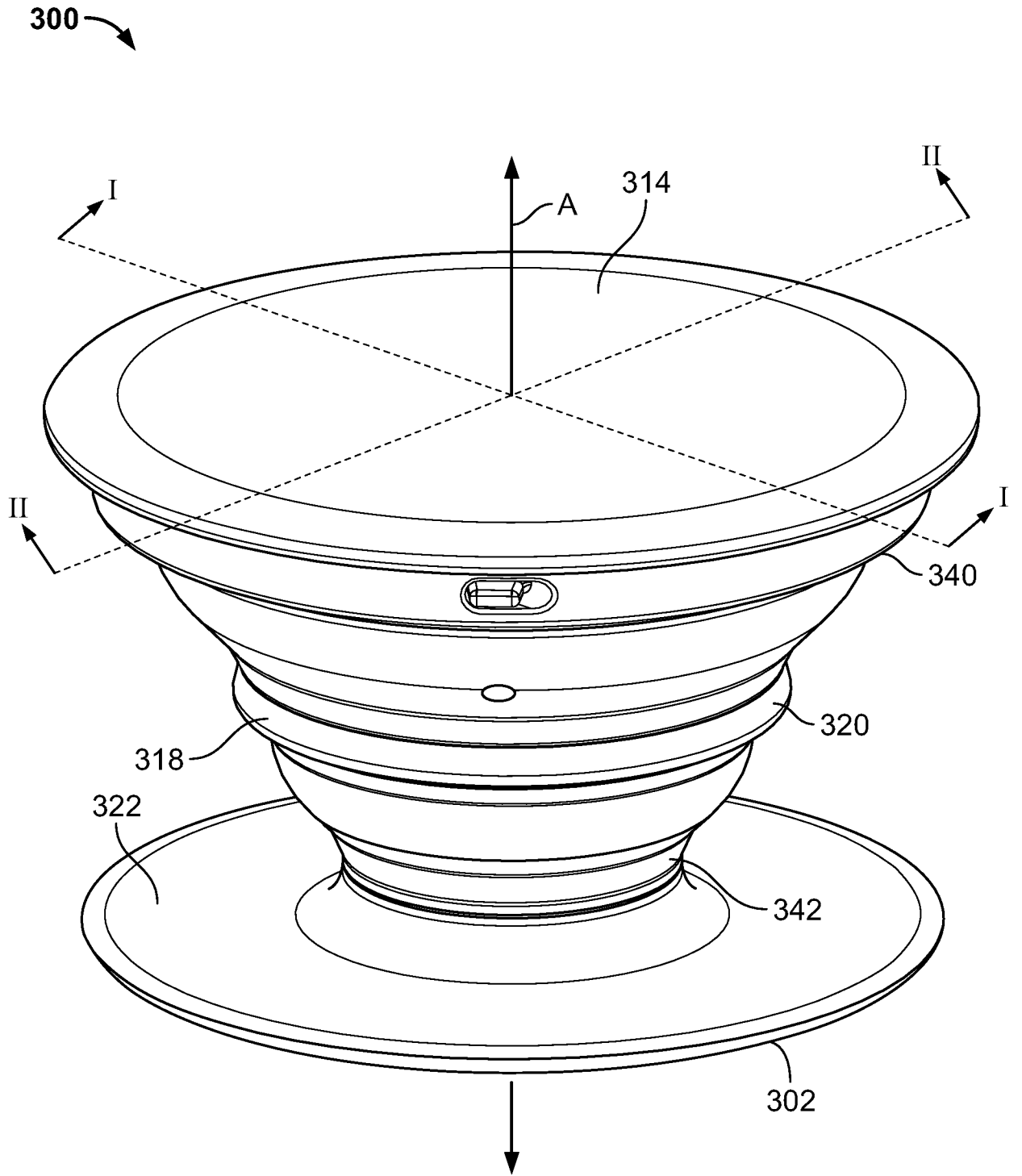

FIG. 5

4/11

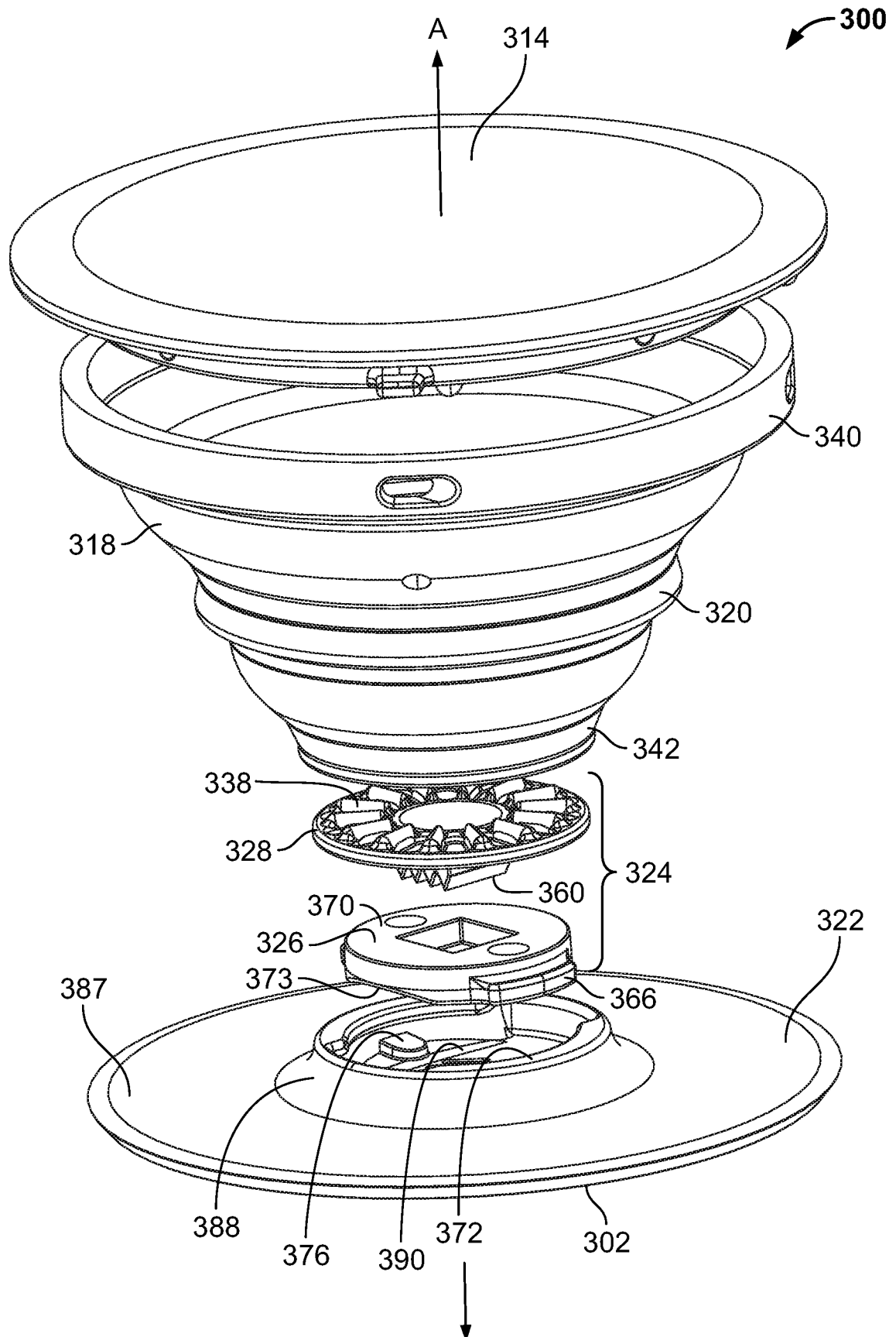

FIG. 6

5/11

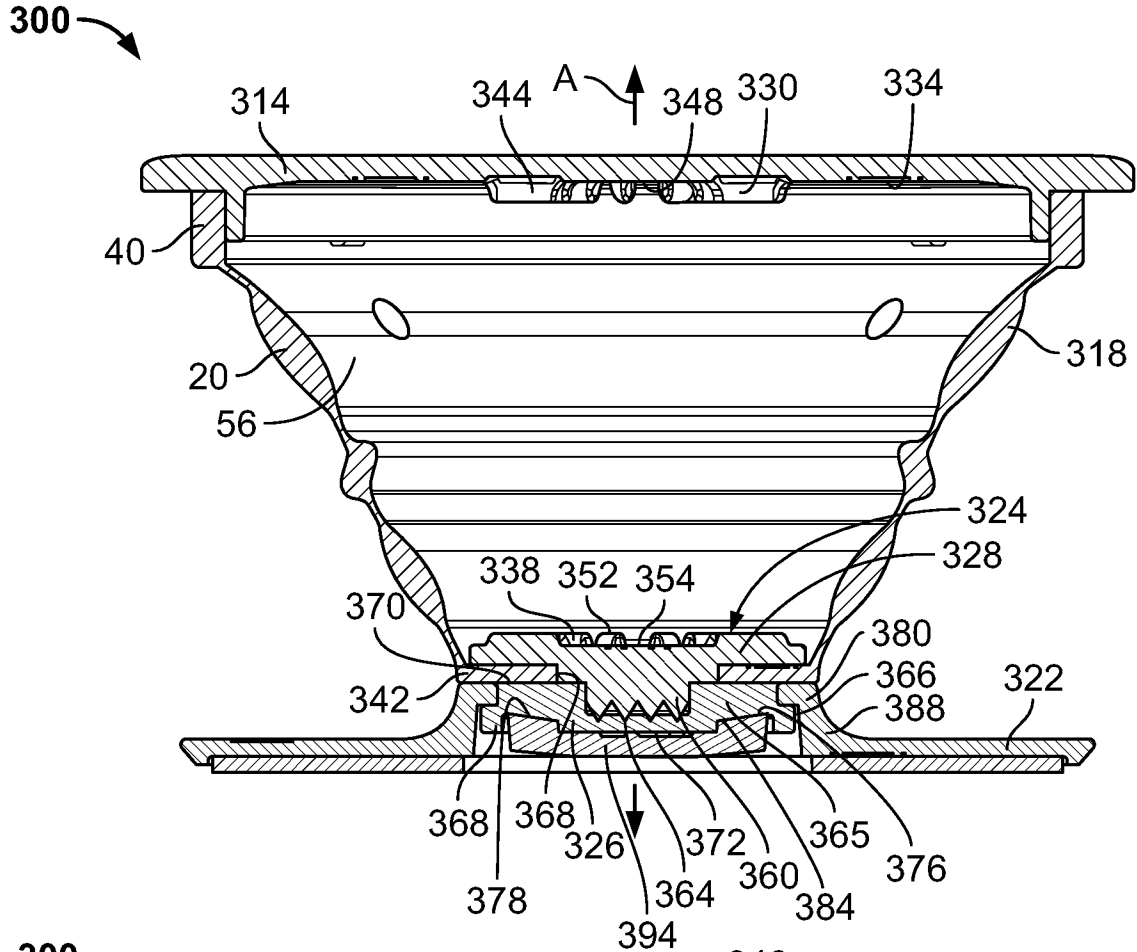

FIG. 7

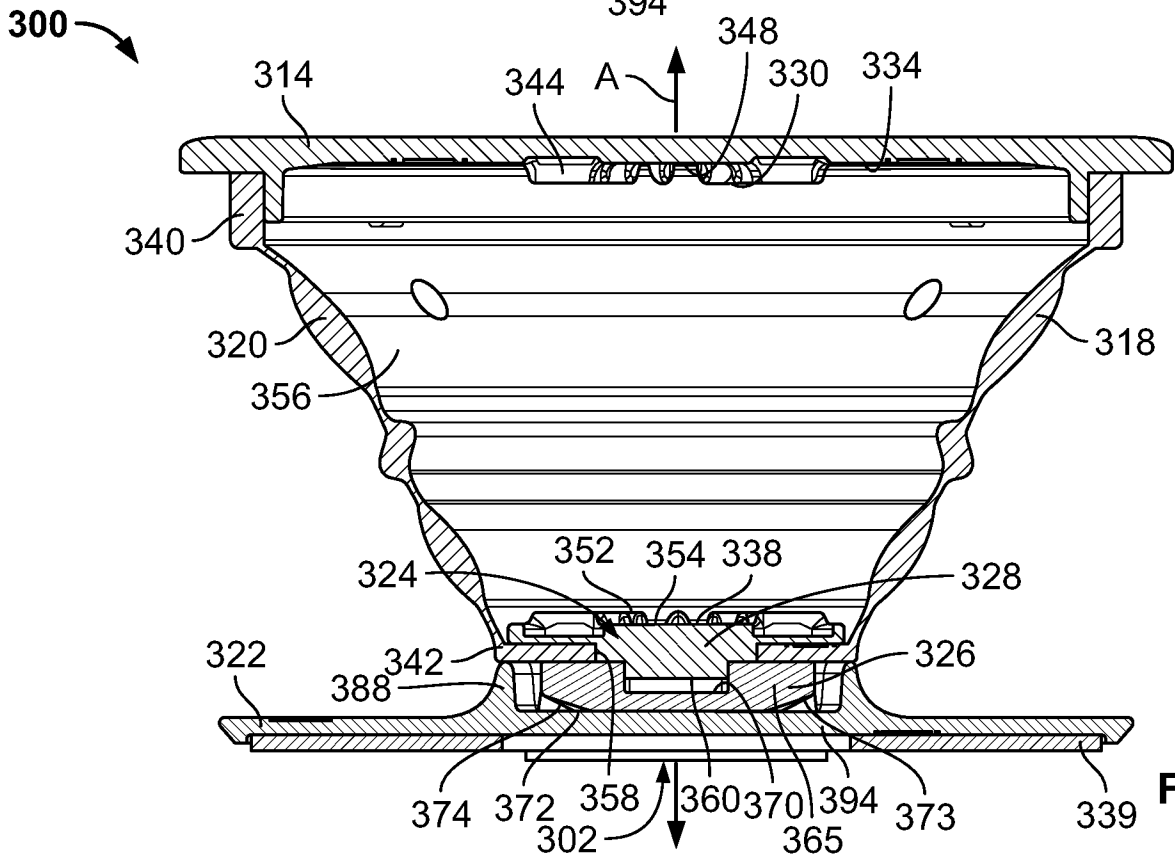

FIG. 8

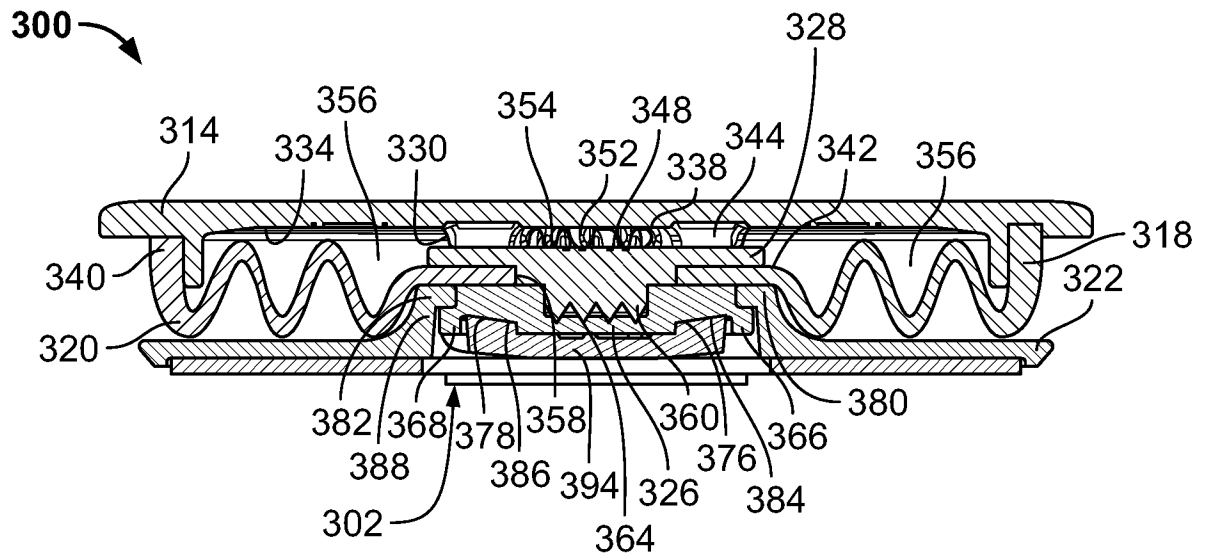

FIG. 9

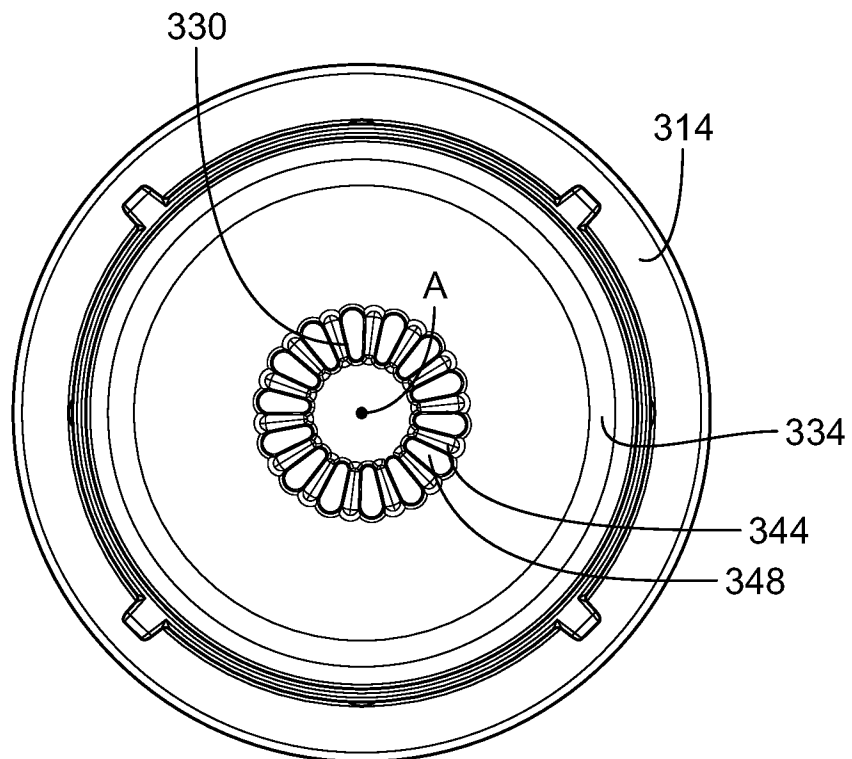

FIG. 10

7/11

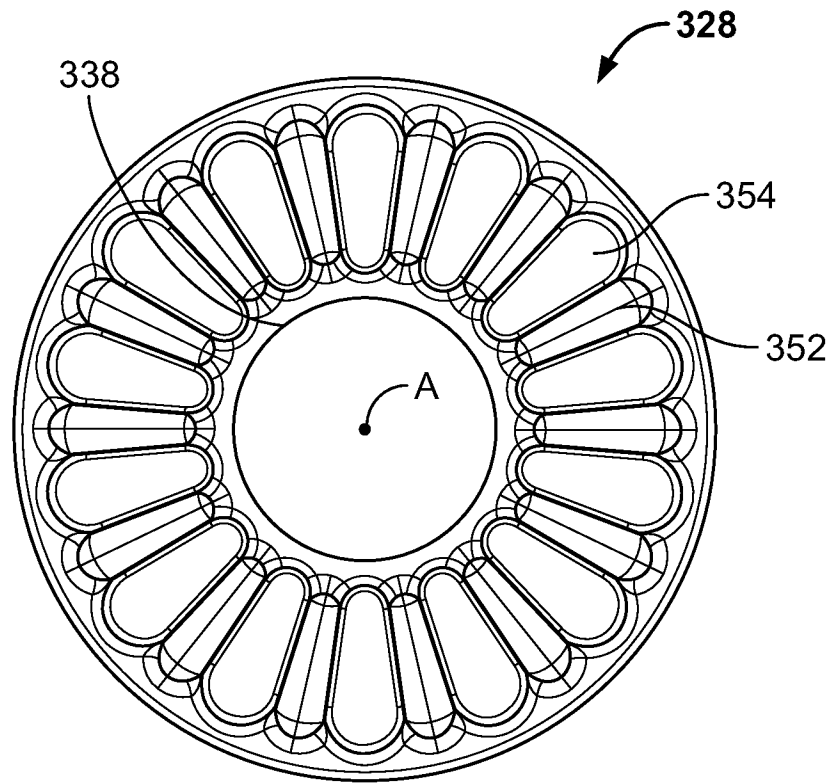

FIG. 11

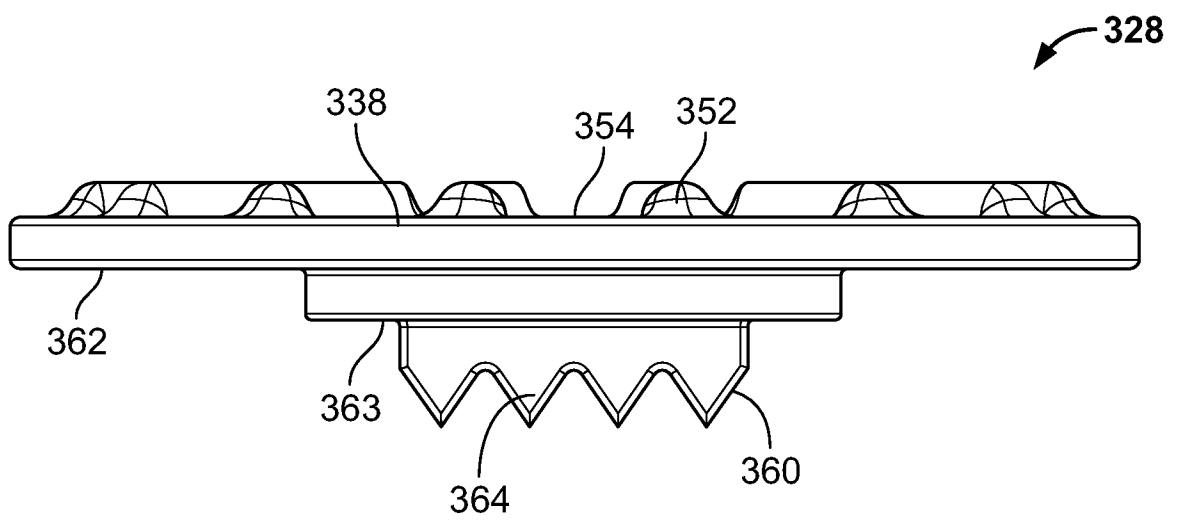

FIG. 12

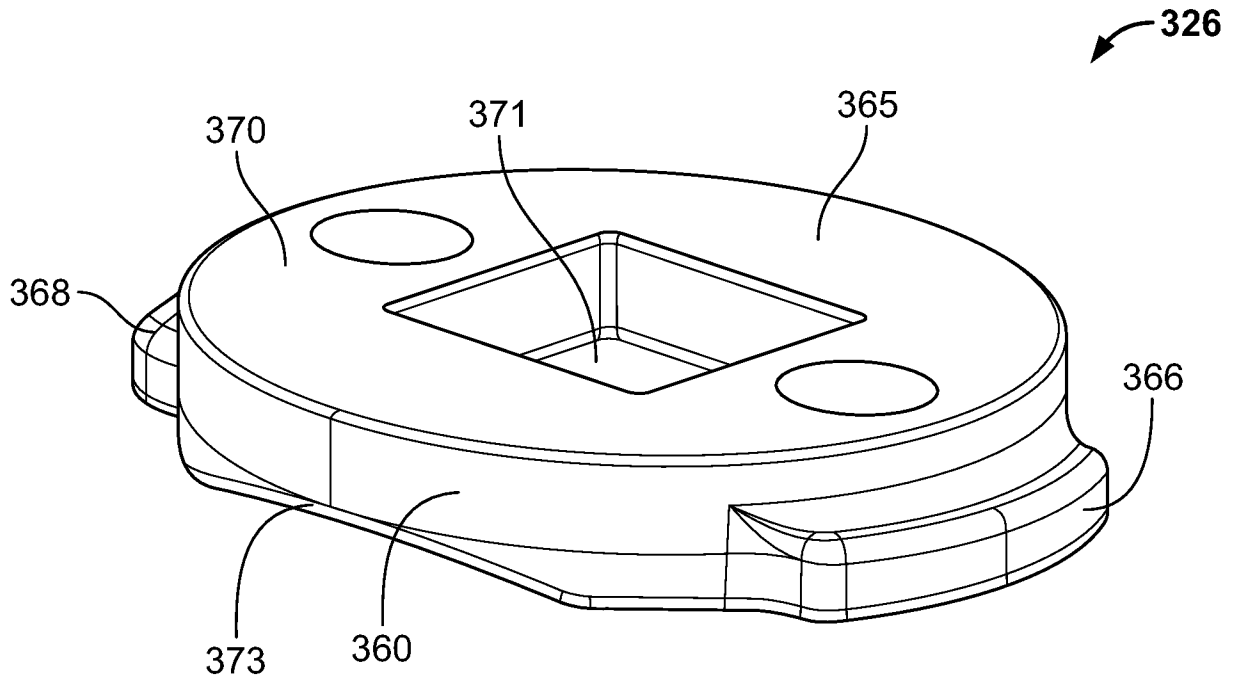

FIG. 13

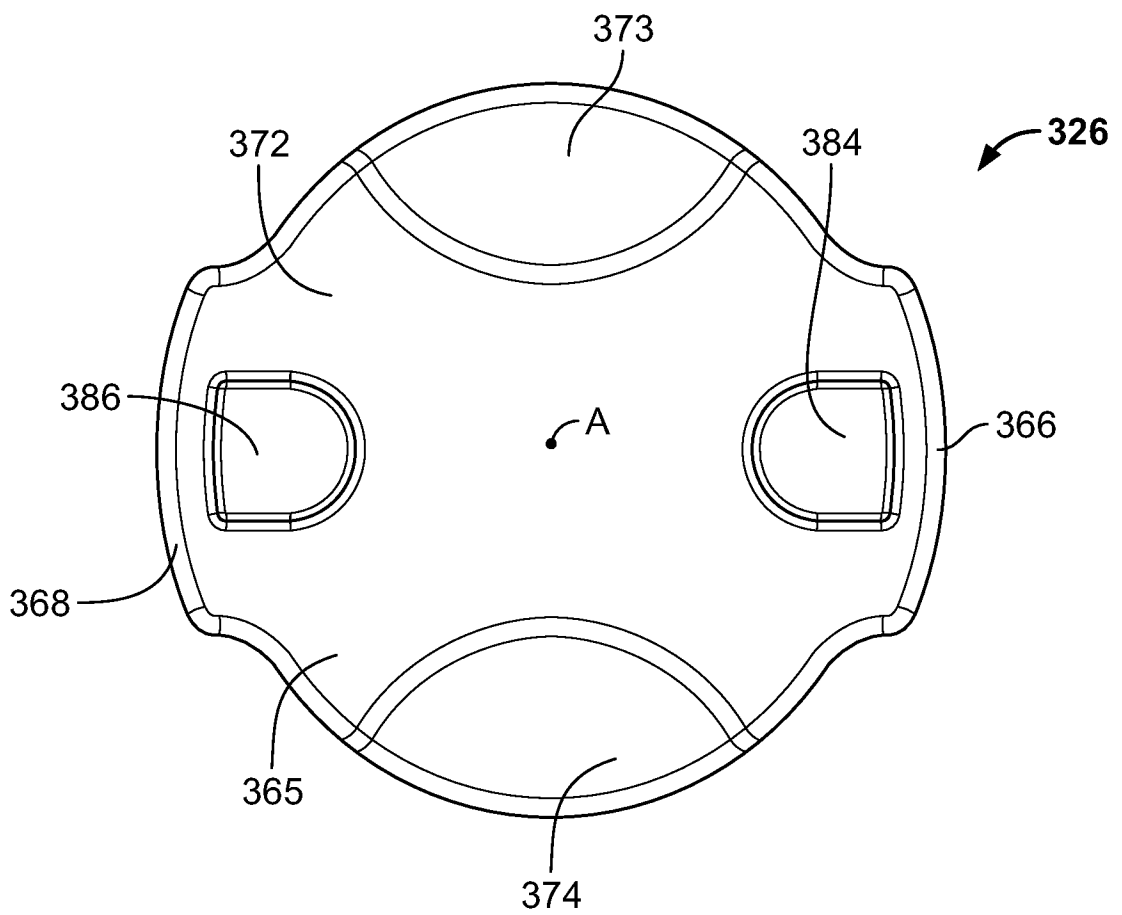

FIG. 14

9/11

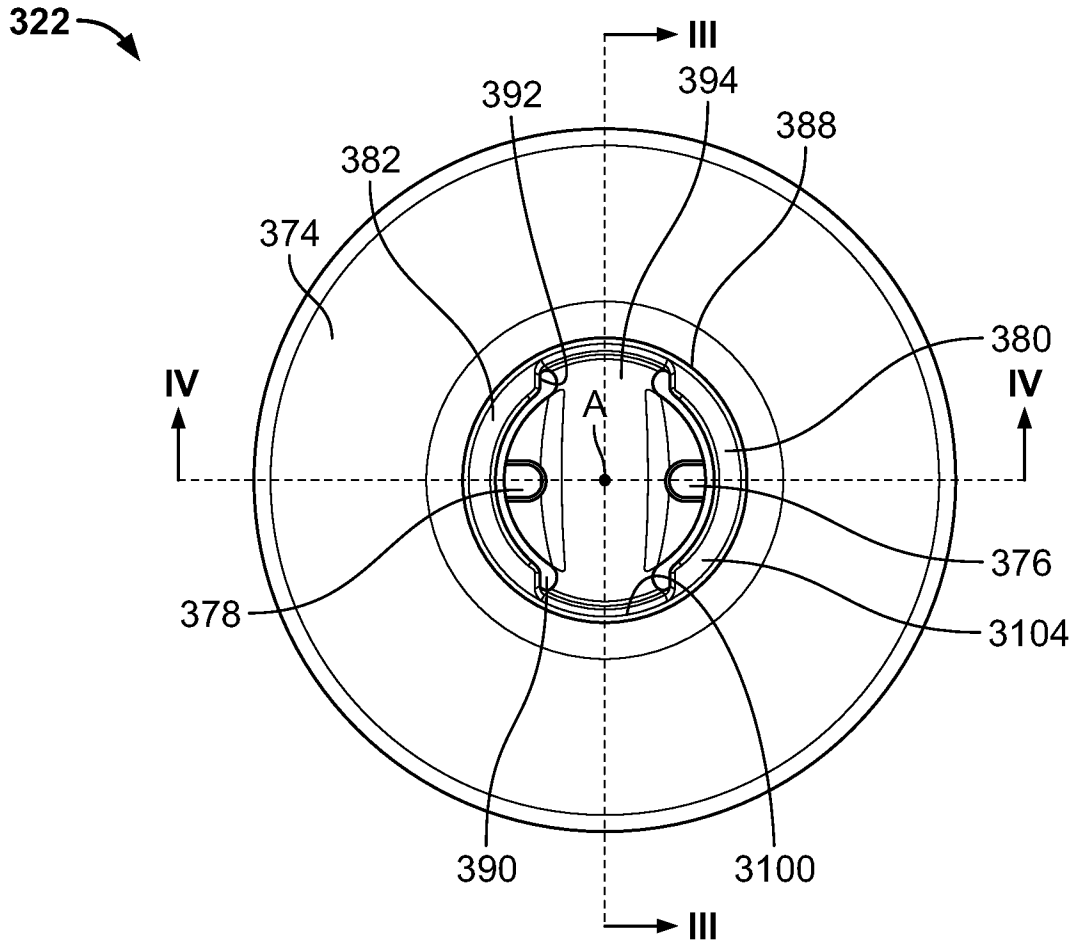

FIG. 15

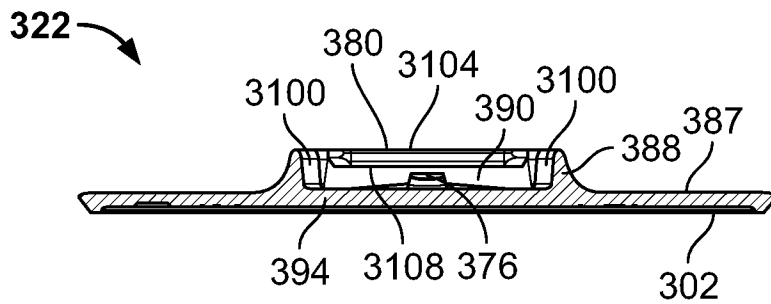

FIG. 16

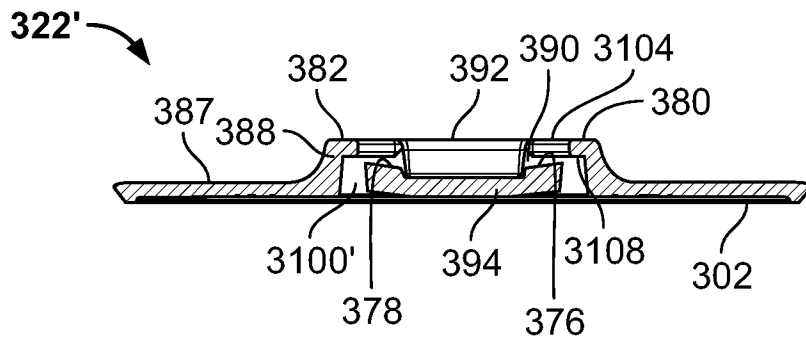

FIG. 17

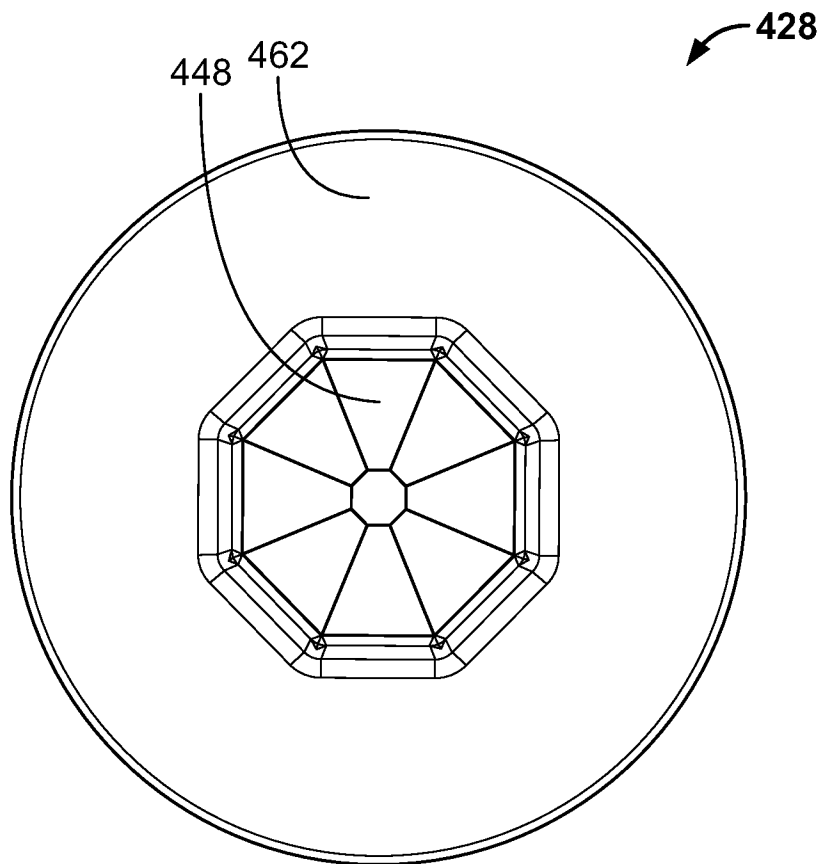

FIG. 20

INTERNATIONAL SEARCH REPORT

International application No
PCT/US2019/051394

A. CLASSIFICATION OF SUBJECT MATTER					
INV.	F16M11/04	A45F5/00	A45F5/02	H04B1/3888	H04M1/02
	A44B99/00	F16M11/38	F16M13/00	F16M13/02	F16M13/04
	G06F1/16	H04M1/04	A45F5/10	F16M11/16	F16M11/20
According to International Patent Classification (IPC) or to both national classification and IPC					

B. FIELDS SEARCHED
Minimum documentation searched (classification system followed by classification symbols)
F16M

Documentation searched other than minimum documentation to the extent that such documents are included in the fields searched

Electronic data base consulted during the international search (name of data base and, where practicable, search terms used)
EPO-Internal, WPI Data

C. DOCUMENTS CONSIDERED TO BE RELEVANT

Category*	Citation of document, with indication, where appropriate, of the relevant passages	Relevant to claim No.
X	WO 2018/187278 A1 (POPSOCKETS LLC [US]) 11 October 2018 (2018-10-11) the whole document -----	1-14
X	US 8 560 031 B2 (BARNETT DAVID B [US]; CARLSON LAWRENCE E [US]) 15 October 2013 (2013-10-15) cited in the application abstract; figures 1-9,12a,12b column 5, line 7 - column 6, line 22 -----	1-14
X	US 2018/051851 A1 (HOBBS MOLLY [US] ET AL) 22 February 2018 (2018-02-22) abstract; figures 1,2 -----	1-14
A	WO 2016/205041 A1 (AIRO COLLECTIVE INC [US]) 22 December 2016 (2016-12-22) abstract; figures 1-11 pages 10-11 -----	1-4,9-11

Further documents are listed in the continuation of Box C.

See patent family annex.

* Special categories of cited documents :

"A" document defining the general state of the art which is not considered to be of particular relevance	"T" later document published after the international filing date or priority date and not in conflict with the application but cited to understand the principle or theory underlying the invention
"E" earlier application or patent but published on or after the international filing date	"X" document of particular relevance; the claimed invention cannot be considered novel or cannot be considered to involve an inventive step when the document is taken alone
"L" document which may throw doubts on priority claim(s) or which is cited to establish the publication date of another citation or other special reason (as specified)	"Y" document of particular relevance; the claimed invention cannot be considered to involve an inventive step when the document is combined with one or more other such documents, such combination being obvious to a person skilled in the art
"O" document referring to an oral disclosure, use, exhibition or other means	"&" document member of the same patent family
"P" document published prior to the international filing date but later than the priority date claimed	

Date of the actual completion of the international search 13 November 2019	Date of mailing of the international search report 26/11/2019
---	--

Name and mailing address of the ISA/ European Patent Office, P.B. 5818 Patentlaan 2 NL - 2280 HV Rijswijk Tel. (+31-70) 340-2040, Fax: (+31-70) 340-3016	Authorized officer Larrañeta Reclusa, I
--	--

INTERNATIONAL SEARCH REPORT

Information on patent family members

International application No

PCT/US2019/051394

Patent document cited in search report	Publication date	Patent family member(s)	Publication date	
WO 2018187278	A1	11-10-2018	AU 2018249514 A1	24-10-2019
			CA 3058644 A1	11-10-2018
			US 2019335031 A1	31-10-2019
			WO 2018187278 A1	11-10-2018

US 8560031	B2	15-10-2013	CA 2828357 A1	20-09-2012
			CN 103703428 A	02-04-2014
			CN 107967032 A	27-04-2018
			CY 1119592 T1	07-03-2018
			DE 202012013562 U1	07-11-2017
			DK 2686751 T3	20-11-2017
			DK 3309650 T3	19-08-2019
			EP 2686751 A1	22-01-2014
			EP 3309650 A1	18-04-2018
			EP 3514659 A1	24-07-2019
			ES 2642882 T3	20-11-2017
			HR P20171507 T1	01-12-2017
			HU E034626 T2	28-02-2018
			JP 6091438 B2	08-03-2017
			JP 2014513884 A	05-06-2014
			LT 2686751 T	10-11-2017
			PT 2686751 T	01-12-2017
			SI 2686751 T1	29-12-2017
			US 2012329534 A1	27-12-2012
			WO 2012125690 A1	20-09-2012

US 2018051851	A1	22-02-2018	AU 2017312647 A1	28-02-2019
			BR 112019003105 A2	21-05-2019
			CA 3034278 A1	22-02-2018
			CN 109073139 A	21-12-2018
			EP 3440393 A1	13-02-2019
			GB 2564628 A	16-01-2019
			JP 2019527003 A	19-09-2019
			KR 20180030093 A	21-03-2018
			KR 20190032298 A	27-03-2019
			US 9958107 B1	01-05-2018
			US 2018051846 A1	22-02-2018
			US 2018051851 A1	22-02-2018
			US 2018066791 A1	08-03-2018
			US 2018187823 A1	05-07-2018
			US 2018202599 A1	19-07-2018
			US 2018231179 A1	16-08-2018
			US 2018283600 A1	04-10-2018
			US 2019186680 A1	20-06-2019
			US 2019285223 A1	19-09-2019
			WO 2018035349 A1	22-02-2018

WO 2016205041	A1	22-12-2016	US 2016373152 A1	22-12-2016
			WO 2016205041 A1	22-12-2016
