

18



Europäisches Patentamt  
European Patent Office  
Office européen des brevets



11 Publication number:

**0 476 754 B1**

12

### EUROPEAN PATENT SPECIFICATION

45 Date of publication of patent specification: **15.03.95** 51 Int. Cl.º: **B60R 11/02, G07C 9/00**

21 Application number: **91202321.5**

22 Date of filing: **11.09.91**

54 ~~Microprocessor-controlled apparatus including an antitheft protection means which can be disabled.~~

30 Priority: **17.09.90 NL 9002035**

43 Date of publication of application:  
**25.03.92 Bulletin 92/13**

45 Publication of the grant of the patent:  
**15.03.95 Bulletin 95/11**

84 Designated Contracting States:  
**DE FR GB IT**

56 References cited:  
**EP-A- 0 350 119 DE-A- 3 723 931**  
**FR-A- 2 611 623 NL-A- 8 304 138**  
**US-A- 4 494 114 US-A- 4 604 708**

**ELEKTRONIK, vol. 27, no. 13, November 1978,  
München, DE, page 46;  
LIEL: "PROGRAMMIERBARES CODESCH-  
LOSS MIT DOPPELTER VERRIEGELUNG"**

**IBM TECHNICAL DISCLOSURE BULLETIN, vol.  
25, no. 4, September 1975, NEW YORK US,  
pages 1975-1977; COMPTON: " THEFT PRO-  
TECTION FOR TYPEWRITERS"**

73 Proprietor: **Philips Electronics N.V.**  
**Groenewoudseweg 1**  
**NL-5621 BA Eindhoven (NL)**

72 Inventor: **Wassink, Derk Jan Chris**  
**c/o INT. OCTROOIBUREAU B.V.,**  
**Prof. Holstlaan 6**  
**NL-5656 AA Eindhoven (NL)**

74 Representative: **Steenbeek, Leonardus Johan-  
nes**  
**INTERNATIONAAL OCTROOIBUREAU B.V.,**  
**Prof. Holstlaan 6**  
**NL-5656 AA Eindhoven (NL)**

**EP 0 476 754 B1**

Note: Within nine months from the publication of the mention of the grant of the European patent, any person may give notice to the European Patent Office of opposition to the European patent granted. Notice of opposition shall be filed in a written reasoned statement. It shall not be deemed to have been filed until the opposition fee has been paid (Art. 99(1) European patent convention).

## Description

The invention relates to a microprocessor-controlled apparatus including an anti-theft protection means which can be disabled. More particularly, the invention relates to a consumer apparatus which is considered liable to theft. Such an apparatus may be, for example, a car radio, CD player, video recorder, camera recorder, and the like.

An apparatus of the type described in the opening paragraph is known from Netherlands Patent Application NL 8304138. A control circuit in this known apparatus is adapted, *inter alia*, to perform a legitimization program for putting the apparatus into operation after it has been connected to the supply voltage. The legitimization program comprises a comparison of a legitimization code, entered by the user, with a security code stored in a first memory. Unauthorized use of the apparatus is thus prevented, rendering theft unattractive.

In practice it has been found useful to offer the owner of a apparatus the facility of disabling the anti-theft protection means. This is notably the case when using a car radio which is mounted in a so-called slide and is each time taken along by the owner in order to prevent car damage caused by burglars. To this end the prior art apparatus comprises a second memory for storing a security variable which is constituted in the known apparatus by a indication bit indicating whether the protection means is enabled. If the protection means is not enabled, the legitimization program is not performed so that the car radio can be readily put into operation after it has been placed in the slide. Said second memory for storing the security variable is necessarily a non-volatile RAM. In practice it is constituted by an external memory coupled to the microprocessor. The known apparatus has the drawback that such an external memory is externally accessible to frauds. For example, the indication bit of a protected car radio can be read with the aid of auxiliary means and stored again after inversion. The car radio is then no longer protected and is therefore attractive to the illegal trade.

It is an object of the invention to provide a microprocessor-controlled apparatus including an anti-theft protection means which can be disabled and which obviates the drawbacks mentioned above and considerably reduces the risk of theft.

To this end the apparatus according to the invention is characterized in that a code series comprising a plurality of bits is stored in an internal memory of the microprocessor, and in that, in response to the disable command, the microprocessor is adapted to assign a value corresponding to the code series to the security variable so as to indicate that the protection means is disabled. It is thereby achieved that external reading of the secu-

rity variable in the second, external memory does not yield any useful information for unauthorized use of the apparatus. In fact, in an apparatus with its protection means enabled, the security variable which has been read has a value which does not correspond to the code series, for example, the value of zero. Overwriting of this value by another value with the aid of external auxiliary means has no effect at all, unless the value corresponding to the code series is known and is written into the memory. However, the code series is even unknown to the owner and can neither be read from the inaccessible internal memory of the microprocessor. The code series may be arbitrarily extensive, thus discouraging the use of "trial and error" methods to a sufficient extent. The code series can of course be read from the apparatus whose protection means has already been disabled. However, for obvious reasons this is useless.

It is to be noted that it is known *per se* from the article "Programmierbares Codeschloß mit doppelter Verriegelung", published in *Elektronik* 1978, Heft 13, page 46, to store in an apparatus both a security code and a code series comprising a plurality of bits. In this known apparatus, however, the code series constitutes an additional code to be entered by the user after he failed to enter the correct security code, and is not used to indicate that the protection means is disabled.

A further embodiment of the apparatus is characterized in that the microprocessor is adapted to perform the legitimization program with a predetermined time delay after the apparatus has been put into operation, if the security variable does not have the value corresponding to the code series. Any attempt to "break" the code series, for example, by successively writing different values of the security variable into the second memory by means of a personal computer can only be checked for the achieved effect after said period of time has elapsed. For the authorized user, who wants to put a protected apparatus into operation quickly, said period of time may be made acceptably short by giving the code series a sufficient length.

In practice it is desirable that only the authorized user can disable the protection means. A disable command intended for this purpose is to enter the correct legitimization code with which the desired adaptation of the security variable is realized. It is conceivable that it is attempted to trace the legitimization code by means of this method. For example, the effect of successively generated legitimization codes on the security variable stored in the external memory can be analysed with the aid of external auxiliary means. In order to impede this, a further embodiment of the apparatus is characterized in that the microprocessor is adapted to as-

sign the value corresponding to the code series to the security variable when a predetermined period of time after the disable command has elapsed. Any "trial and error" attempt to trace the legitimation code in this way can now be checked for the desired effect only after this period of time has elapsed. In practice the period of time will be chosen to be sufficiently long so as to avoid inconveniently long legitimation codes. Similar considerations also apply when the protection means is enabled again in response to an enable command.

A further embodiment of the apparatus is characterized in that the security code is also stored in the internal memory of the microprocessor. It is thereby achieved that, likewise as the code series, the security code is not externally accessible. It is to be noted that it is known *per se* from United States Patent US 4,494,114 to store the security code in the internal memory of the microprocessor which is externally inaccessible. However, this Patent refers to an apparatus which is not provided with an anti-theft protection means which can be disabled.

The microprocessor is preferably of a type whose internal memory is one-time programmable. Unlike the conventional microprocessors, large numbers of which are provided with an identical program by the microprocessor manufacturer, this type of microprocessor is programmed by the apparatus manufacturer. It is thereby achieved that the apparatuses of one production batch can be provided with different code series and security codes. If the code series or the security code of an apparatus has possibly been "broken" successfully, it does not yield any information for unauthorized use of another apparatus from the same production batch. The code series programmed by the apparatus manufacturer may be arbitrary and need not be registered. The security code, for example, a 4-digit number is registered on a passport and handed over to the buyer of the relevant car radio. Said microprocessors which can be programmed once are known under the name of OTP (One Time Programmable).

Fig. 1 shows a car radio as an embodiment of a microprocessor-controlled apparatus according to the invention.

Figs. 2-4 show flow charts to explain the operation of the car radio shown in Fig. 1.

Fig. 1 shows a car radio as an embodiment of a microprocessor-controlled apparatus having an anti-theft protection means which can be disabled. The car radio receives transmitter signals *via* an aerial 1, which signals are applied to a signal input 21 of a tuning circuit 2. Tuning to a transmitter is effected in response to tuning signals which are applied to a control input 22 of the tuning circuit.

The tuning circuit 2 supplies a demodulated audio signal  $a(t)$  which is made audible in loudspeakers 41 and 42 *via* a signal processing circuit 3. In the signal processing circuit 3, *inter alia*, the volume, tone control, balance and the like of the audio signal are influenced by means of control signals which are applied to a control input 31.

The car radio further comprises a microprocessor 5, preferably of a one-time programmable type. An example of such a microprocessor is the type TMP47P800N of the firm of Toshiba. The microprocessor 5 comprises an internal memory 51 in which a control program CTRL and fixed data are stored by the car radio manufacturer. The fixed data comprise, *inter alia*, a security code SC and a code series KEY. The security code SC is a number comprising, for example, four decimals, and the code series KEY is formed by a bit series of, for example, 20 bits. Unlike the control program CTRL, which is identical for all car radios from one production batch, the security code SC and the code series KEY preferably have a different value for each car radio. When the microprocessor is being programmed, the security code SC is registered in a passport which is handed over to the buyer of the car radio. The code series KEY may be a completely arbitrary bit series and need not be registered.

The microprocessor 5 has a plurality of terminals 52 for transporting signals from and to the microprocessor. The connections connected thereto are shown in the form of a communication bus 6. The previously mentioned tuning signals and control signals are generated by the microprocessor and applied by means of this communication bus to the tuning circuit 2 and the signal processing circuit 3. A non-volatile memory 7, a display circuit 8 and an operating field 9 are coupled to the microprocessor by means of the communication bus. The non-volatile memory 7 is intended to store data therein which may not get lost when the apparatus is switched off, for example, tuning data of preset stations. The non-volatile memory is particularly adapted to store a security variable VAR which comprises as many bits as the previously mentioned code series KEY. The operating field 9 comprises search keys 91 and 92 for automatically searching transmitters and a plurality of program keys 93 for directly selecting previously programmed preset stations. The program keys 93 are also used for entering a legitimation code which will hereinafter be referred to as LC.

The microprocessor is connected by means of a voltage converter 10 to an external power supply source which is constituted by a battery 11 having a voltage of 12 Volts. The voltage converter 10 converts this voltage into a voltage of 5 Volts desired for the microprocessor and applies this

voltage to a terminal VCC of the microprocessor. A power-on-reset circuit 12 further connected to the voltage converter 10 is adapted to generate a reset signal when the radio is connected to the battery and to apply this signal to a terminal denoted by RST in the Figure. The other circuits of the car radio receive their supply voltage from a further voltage converter 13 which is connected to the battery 11 *v/a* an on/off switch 14. This further voltage converter also applies a binary signal PWR to a terminal 53 of the microprocessor. This signal PWR indicates, for example, by means of the logic value "1" that the car radio is put into operation by means of the on/off switch 14.

The operation of the car radio shown in Fig. 1 is completely determined by the control program CTRL which is stored in the internal memory 51 of the microprocessor 5. Fig. 2 shows a flow chart of this control program. It is started if the car radio is connected to the battery and if in response thereto the microprocessor receives the reset signal at the terminal RST. The car radio need not yet have been put into operation by means of the on/off switch 14 (see Fig. 1). The control program as yet only performs a step 100, *i.e.* it assigns the logic value "1" to a logic variable INIT. Subsequently the program waits in a step 101 until the signal PWR applied to the terminal 53 (see Fig. 1) assumes the logic value "1". The car radio has then been put into operation by means of the on/off switch 14. In a step 102 a background program PLAY is subsequently started. This program ensures the functional control of the car radio. It scans the keys of the operating field 9 (see Fig. 1) and in response thereto it controls the tuning circuit 2, the signal processing circuit 3 and the display circuit 8 in known manner.

Subsequently a toggle program TGGL is performed in a step 103. This toggle program provides the user with the possibility of optionally enabling or disabling the protection means of the car radio. It will hereinafter be described in greater detail.

In a step 104 it is subsequently checked whether the logic variable INIT has the value "1". This is the case if the car radio is put into operation for the first time after it has been connected to the battery. In a step 105 it is then checked whether the security variable VAR stored in the non-volatile memory 7 (see Fig. 1) corresponds to the code series KEY stored in the internal microprocessor memory 51 (see Fig. 1). If VAR and KEY are equal, the protection means of the car radio is disabled. The value "0" is then assigned in a step 106 to the logic variable INIT. The car radio then functions without any interference until the apparatus is switched off by means of the on/off switch 14 (see Fig. 1).

If it has been determined in step 105 that the security variable VAR is not equal to the code series KEY, the protection means of the car radio is enabled. In a step 107 of the control program the sound reproduction is then disturbed, for example, by periodically suppressing the sound. Subsequently the user is given the opportunity to legitimize himself in a step 108. A legitimation program LEG suitable for this purpose is shown in Fig. 3. It comprises a step 110 for entering a legitimation code LC which is compared in a step 111 with the security code SC stored in the internal microprocessor memory 51 (see Fig. 1). The legitimation program is not left until the correct legitimation code has been entered. Meanwhile, the sound reproduction remains disturbed. When the correct code has been entered, the legitimation program is left. In a step 109 of the control program (see Fig. 2) the disturbance of the sound reproduction is eliminated and the value "0" is assigned in the step 106 to the logic variable INIT.

Whenever the car radio is put into operation by means of the on/off switch 14 (see Fig. 1) without having been released from the battery, the control program is resumed as from the step 101. The logic variable INIT then invariably has the value "0". In the step 104 it is then determined that the legitimation program need no longer be run through, even if the protection means has been enabled.

Fig. 4 illustrates the toggle program TGGL shown in Fig. 2 for enabling or disabling the protection means. In a step 112 of this toggle program it is checked whether the search key 91 of the operating field (see Fig. 1) was activated while the car radio was being put into operation. This is interpreted as a command for enabling the protection means. In a corresponding manner it is checked in a step 113 whether a command for disabling the protection means was generated by activating the search key 92 of the operating field while the car radio was being put into operation. If either one of the two cases occurs, the previously described legitimation program LEG is performed in a step 114. After the correct legitimation code has been received, the security variable VAR is adapted in a step 116. If it is a disable command, the value which corresponds to the code series KEY is assigned to VAR so as to indicate that the protection means is disabled, while VAR is assigned the value 0 when an enable command is concerned. The logic variable INIT (which has the value "1" when the relevant switch-on or switch-off procedure is performed after the car radio has been connected to the battery) is now assigned the value "0" in a step 117. Fig. 4 also shows an optional step 115 in which a predetermined waiting time is observed for adapting the security variable

VAR in response to entering the legitimation code. It is thereby avoided that it can immediately be ascertained by means of interrogation of the non-volatile memory with the aid of external auxiliary means whether an arbitrarily entered legitimation code influences the value of VAR.

It is to be noted that it is useful to perform the step denoted by 107 in Fig. 2 for disturbing the sound reproduction in such a way that the first disturbance does not occur until after a predetermined period of time, for example, after 2 sec. If an arbitrary value for the security variable VAR is written in an unauthorized way and with external means into the non-volatile memory of a protected car radio, it will not be apparent until 2 sec after the car radio has been switched on whether it is still protected. If the code series KEY comprises 20 bits, it takes an average of  $\frac{1}{2} \cdot 2^{20} \cdot 2$  sec, or 12 days, to break the code series in this manner and to disable the protection means in this unauthorized way. The first disturbance may occur for a short period, while the sound is subsequently reproduced undisturbed for some time. This is important when the car radio must be inspected after it has been built in by the garage mechanic and when the car radio must be serviced by a dealer.

#### Claims

1. A microprocessor-controlled apparatus including an anti-theft protection means which can be disabled, comprising:
  - means (9) for generating a legitimation code and a disable command for disabling the protection means;
  - a first memory (51) in which a security code (SC) is stored;
  - a second memory (7) for storing a security variable (VAR) indicating whether the protection means is enabled;
  - a microprocessor (5), coupled to said means (9) and memories (51,7) and, when the protection means is enabled, being adapted to perform a legitimation program (108) so as to compare the generated legitimation code with the stored security code (SC),
 characterized in that a code series comprising a plurality of bits is stored in a internal memory (51) of the microprocessor (5), and in that, in response to the disable command, the microprocessor is adapted to assign (116) a value corresponding to the code series to the security variable (VAR) so as to indicate that the protection means is disabled.
2. An apparatus as claimed in Claim 1, characterized in that the microprocessor is adapted to

perform the legitimation program with a predetermined time delay after the apparatus has been put into operation, if the security variable does not have the value corresponding to the code series.

3. An apparatus as claimed in Claim 1 or 2, characterized in that the microprocessor is adapted to assign the value corresponding to the code series to the security variable when a predetermined period of time after the disable command has elapsed (115).
4. An apparatus as claimed in Claim 1,2 or 3, in which the generating means (9) are further arranged to generate an enable command for enabling the protection means, characterized in that the microprocessor is adapted to assign a value to the security variable other than the value corresponding to the code series when a further predetermined period of time after the enable command has elapsed (115).
5. An apparatus as claimed in Claim 1, characterized in that the security code (SC) is also stored in the internal memory (51) of the microprocessor.
6. An apparatus as claimed in Claim 5, characterized in that the microprocessor is of a type whose internal memory is one-time programmable.

#### Patentansprüche

1. Mikroprozessorgesteuerter Apparat mit einem ausschaltbaren Schutz gegen unbefugten Gebrauch, mit
  - Mitteln (9) zum Erzeugen eines Ausweiscodes und eines Ausschaltbefehls zum Ausschalten der Schutzmittel;
  - einem ersten Speicher (51), in dem ein Sicherheitscode (SC) gespeichert ist;
  - einem zweiten Speicher (7) zum Speichern einer Sicherheitsveränderlichen (VAR), die angibt, ob die Schutzmittel ausgeschaltet sind;
  - einem Mikroprozessor (5), der mit den genannten Mitteln (9) und mit Speichern (51, 7) gekoppelt ist und, wenn die Schutzmittel ausgeschaltet sind, ein Ausweisprogramm (108) durchführt zum Vergleichen des erzeugten Ausweiscodes mit dem gespeicherten Sicherheitscodes (SC),
 dadurch gekennzeichnet, daß in einem inneren Speicher (51) des Mikroprozessors (5) eine Codereihe mit einer Anzahl Bits gespeichert ist

und daß in Antwort auf den Ausschaltbefehl der Mikroprozessor der Sicherheitsveränderlichen (VAR) einen der Codereihe entsprechenden Wert zuordnet um anzugeben, daß die Schutzmittel ausgeschaltet sind.

2. Apparat nach Anspruch 1, dadurch gekennzeichnet, daß der Mikroprozessor das Ausweisprogramm durchführt mit einer vorbestimmten Zeitverzögerung, nachdem der Apparat in Betrieb gesetzt worden ist, wenn die Sicherungsveränderliche nicht den der Codereihe entsprechenden Wert hat.
3. Apparat nach Anspruch 1 oder 2, dadurch gekennzeichnet, daß der Mikroprozessor der Sicherheitsveränderlichen den der Codereihe entsprechenden Wert zuordnet, wenn eine vorbestimmte Zeitperiode nachdem der Ausschaltbefehl verstrichen ist (115).
4. Apparat nach Anspruch 1, 2 oder 3, wobei die Erzeugungsmittel (9) weiterhin einen Einschaltbefehl erzeugen zum Einschalten der Schutzmittel, dadurch gekennzeichnet, daß der Mikroprozessor der Sicherungsveränderlichen einen Wert zuordnet, der anders ist als der Wert entsprechend der Codereihe, wenn eine weitere Zeitperiode nachdem der Einschaltbefehl verstrichen ist (115).
5. Apparat nach Anspruch 1, dadurch gekennzeichnet, daß der Sicherheitscode (SC) ebenfalls in dem inneren Speicher (51) des Mikroprozessors gespeichert ist.
6. Apparat nach Anspruch 5, dadurch gekennzeichnet, daß der Mikroprozessor von dem Typ ist, dessen innerer Speicher einmal programmierbar ist.

#### Revendications

1. Appareil commandé par un microprocesseur comprenant un moyen de protection antivol qui peut être désactivé, comprenant :
  - des moyens (9) pour générer un code de légitimation et une instruction de désactivation pour désactiver le moyen de protection;
  - une première mémoire (51) dans laquelle un code de sécurité (SC) est stocké;
  - une deuxième mémoire (7) pour stocker une variable de sécurité (VAR) indiquant si le moyen de protection est activé, et
  - un microprocesseur (5) couplé audit moyen (9) et aux mémoires (51, 7) et à même, lorsque le moyen de protection

est activé, d'exécuter un programme de légitimation (108) de manière à comparer le code de légitimation généré au code de sécurité stocké (SC),

caractérisé en ce qu'une série de codes comprenant une pluralité de bits est stockée dans une mémoire interne (51) du microprocesseur (5) et en ce que, en réaction à l'instruction de désactivation, le microprocesseur est à même d'assigner (116) une valeur correspondant à la série de codes à la variable de sécurité (VAR) de manière à indiquer que le moyen de protection est désactivé.

2. Appareil selon la revendication 1, caractérisé en ce que le microprocesseur est à même d'exécuter le programme de légitimation avec un retard prédéterminé après que l'appareil a été mis en marche, si la variable de sécurité n'a pas la valeur correspondant à la série de codes.
3. Appareil selon la revendication 1 ou 2, caractérisé en ce que le microprocesseur est à même d'assigner la valeur correspondant à la série de codes à la variable de sécurité lorsqu'une période de temps prédéterminée après l'instruction de désactivation s'est écoulée (115).
4. Appareil selon la revendication 1, 2 ou 3, dans lequel les moyens générateurs (9) sont, en outre, prévus pour générer une instruction d'activation pour activer le moyen de protection, caractérisé en ce que le microprocesseur est à même d'assigner à la variable de sécurité une valeur autre que la valeur correspondant à la série de codes lorsqu'une autre période de temps prédéterminée s'est écoulée après l'instruction d'activation (115).
5. Appareil selon la revendication 1, caractérisé en ce que le code de sécurité (SC) est également stocké dans la mémoire interne (51) du microprocesseur.
6. Appareil selon la revendication 5, caractérisé en ce que le microprocesseur est du type dont la mémoire est programmable une fois.

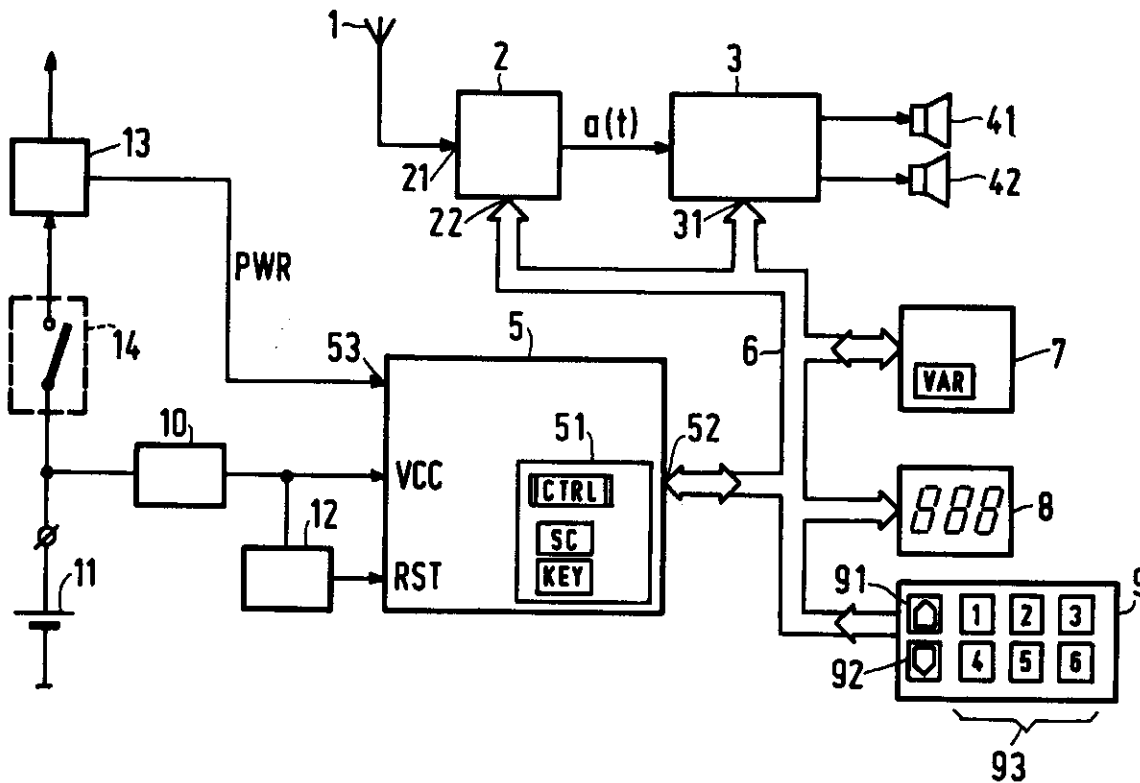

FIG. 1

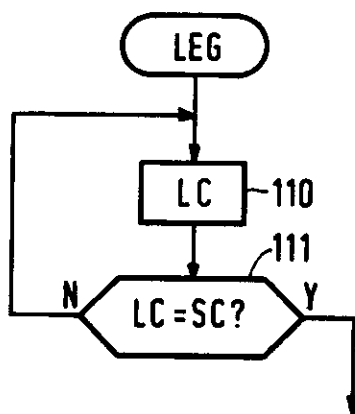
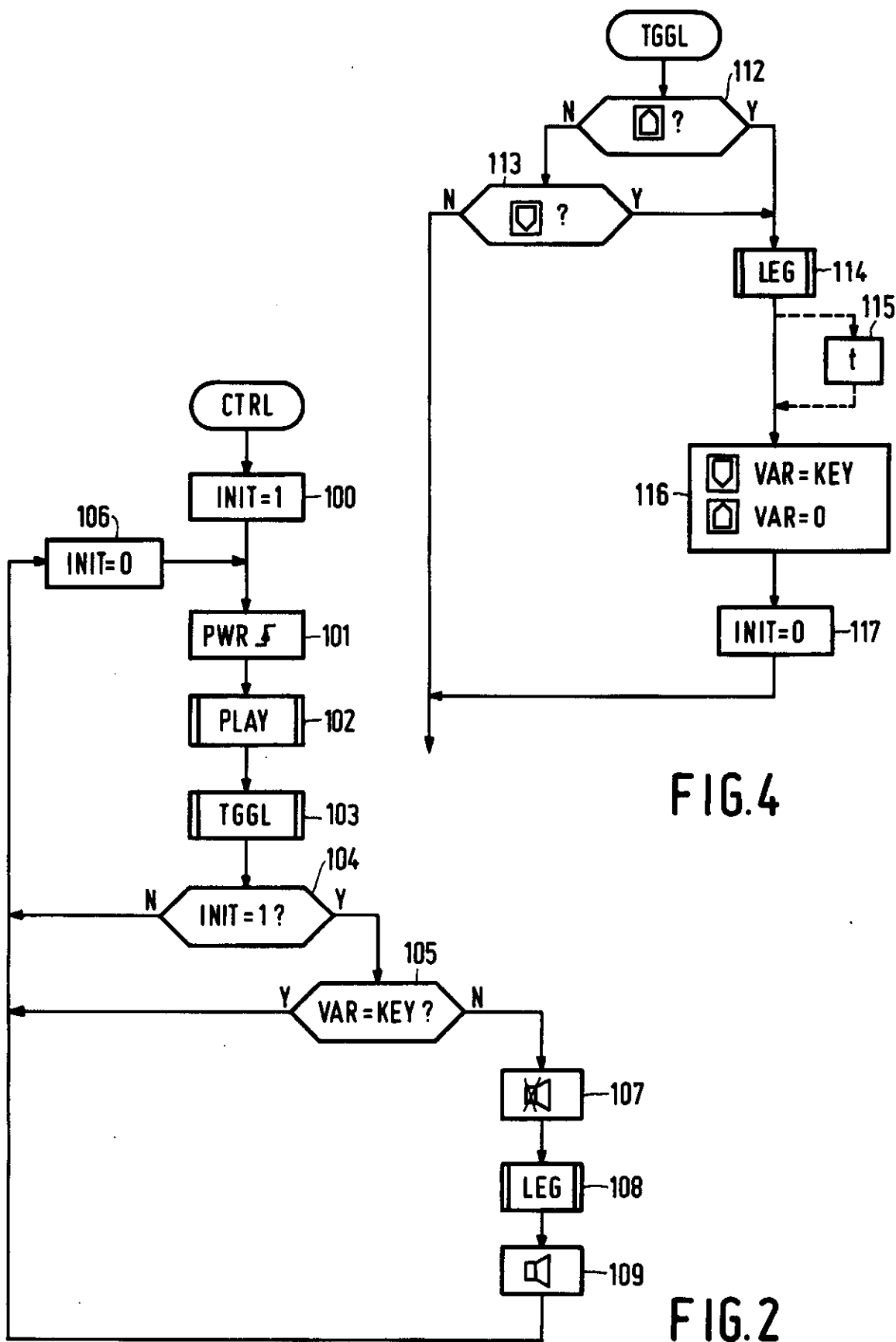

FIG. 3



REGISTER ENTRY FOR EP0476754

European Application No EP91202321.5 filing date 11.09.1991

Application in Dutch

Priority claimed:

17.09.1990 in Netherlands - doc: 9002035

Designated States DE FR GB IT

Title MICROPROCESSOR-CONTROLLED APPARATUS INCLUDING AN ANTITHEFT PROTECTION  
MEANS WHICH CAN BE DISABLED.

Applicant/Proprietor

PHILIPS ELECTRONICS N.V., Groenewoudseweg 1,, NL-5621 BA, Eindhoven,  
Netherlands [ADP No. 06927263001]

Inventor

DERK JAN CHRIS WASSINK, c/o INT. OCTROOIBUREAU B.V., Prof. Holstlaan 6,  
NL-5656 AA Eindhoven, Netherlands [ADP No. 57830796001]

Classified to

B60R G07C

Address for Service

PHILIPS ELECTRONICS, Patents and Trade Marks Department, Cross Oak Lane,  
REDHILL, Surrey, RH1 5HA, United Kingdom [ADP No. 00658492006]

EPO Representative

CORNELIS JOHANNES MARIA VAN GILS, INTERNATIONAAL OCTROOIBUREAU B.V. Prof.  
Holstlaan 6, NL-5656 AA Eindhoven, Netherlands [ADP No. 50728674001]

Publication No EP0476754 dated 25.03.1992

Publication in English

Examination requested 24.09.1992

Patent Granted with effect from 15.03.1995 (Section 25(1)) with title

MICROPROCESSOR-CONTROLLED APPARATUS INCLUDING AN ANTITHEFT PROTECTION  
MEANS WHICH CAN BE DISABLED.

---

23.06.1992 Notification from EPO of change of EPO Representative details from  
CORNELIS JOHANNES MARIA VAN GILS, INTERNATIONAAL OCTROOIBUREAU B.V.  
Prof. Holstlaan 6, NL-5656 AA Eindhoven, Netherlands

[ADP No. 50728674001]

to

LEONARDUS JOHANNES STEENBEEK, INTERNATIONAAL OCTROOIBUREAU B.V.,  
Prof. Holstlaan 6, NL-5656 AA Eindhoven, Netherlands

[ADP No. 59943944001]

Entry Type 25.14 Staff ID. RD06 Auth ID. EPT

\*\*\*\* END OF REGISTER ENTRY \*\*\*\*

OA80-01  
EP

OPTICS - PATENTS

15/02/96

15:01:52

PAGE: 1

RENEWAL DETAILS

PUBLICATION NUMBER

EP0476754

PROPRIETOR(S)

PHILIPS ELECTRONICS N.V., Groenewoudseweg 1,, NL-5621 BA/  
Eindhoven., Netherlands

DATE FILED

11.09.1991

DATE GRANTED

15.03.1995

DATE NEXT RENEWAL DUE

11.09.1996

DATE NOT IN FORCE

DATE OF LAST RENEWAL

31.08.1995

YEAR OF LAST RENEWAL

05

STATUS

PATENT IN FORCE

\*\*\*\* END OF REPORT \*\*\*\*