

No. 688,013.

Patented Dec. 3, 1901.

T. P. BROWN.

PEDAL OPERATING MECHANISM FOR AUTOMATICALLY OPERATED MUSICAL INSTRUMENTS.

(Application filed Mar. 28, 1901.)

(No Model.)

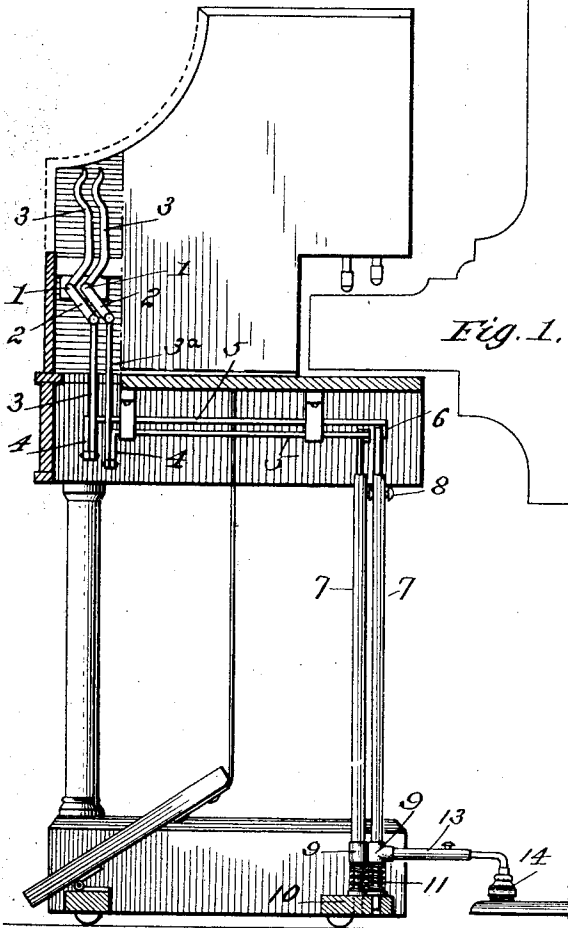

Fig. 1.

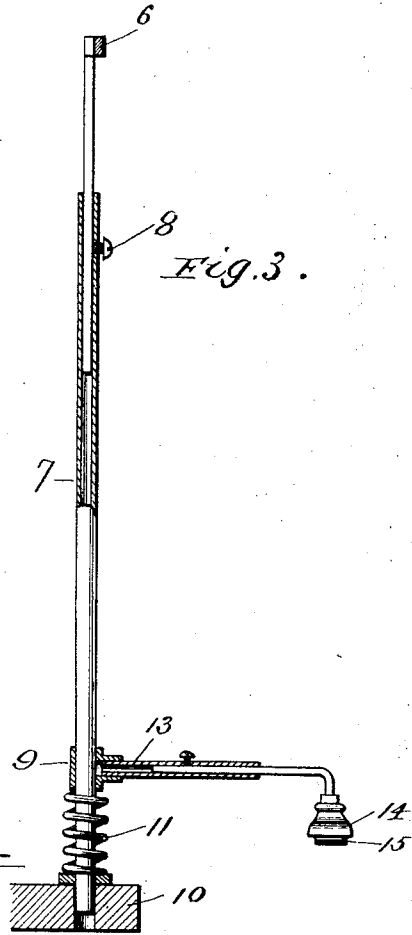

Fig. 3.

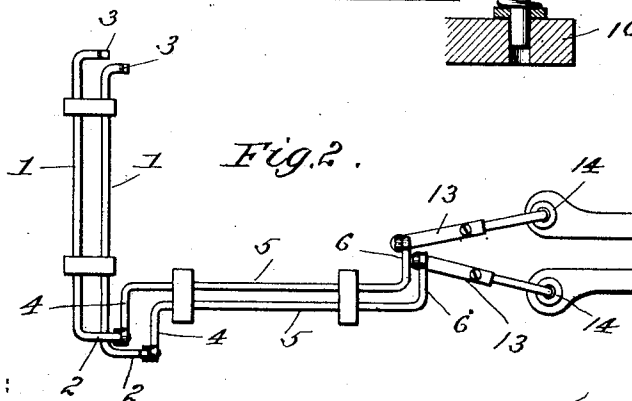

Fig. 2.

WITNESSES:

H. L. Davis

J. G. Chauville Meyers

INVENTOR

Theodore P. Brown

BY

J. Howlett Davis
ATTORNEY

UNITED STATES PATENT OFFICE.

THEODORE PARKER BROWN, OF WORCESTER, MASSACHUSETTS.

PEDAL-OPERATING MECHANISM FOR AUTOMATICALLY-OPERATED MUSICAL INSTRUMENTS.

SPECIFICATION forming part of Letters Patent No. 688,013, dated December 3, 1901.

Application filed March 28, 1901. Serial No. 53,215. (No model.)

To all whom it may concern:

Be it known that I, THEODORE PARKER BROWN, a citizen of the United States, residing at Worcester, in the county of Worcester and State of Massachusetts, have invented certain new and useful Improvements in Pedal-Operating Mechanism for Automatically-Operated Musical Instruments; and I do hereby declare the following to be a full, clear, and exact description of the invention, such as will enable others skilled in the art to which it appertains to make and use the same.

Figure 1 is a vertical sectional view of an automatic musical instrument, showing the pedal-operating means in side elevation. Fig. 2 is a plan view of the pedal-operating means, and Fig. 3 is a detail vertical sectional view of one of the pedal-depressing arms and its supporting-bar.

The object of this invention is to provide simple means to be operated by the hands of a player to positively depress either pedal of the piano, the hand-engaging means being at the front of the casing in position to be conveniently manipulated.

Referring to the parts by numerals, 1 designates a pair of parallel horizontal rock-shafts, which are supported in the casing near to and parallel with the front thereof. On one end of each of these shafts, preferably on the end nearest the center of the casing, is formed a rearward and downward extending crank 2, the other end of each shaft being provided with an upward-extending substantially vertical hand-engaging lever 3, which is in convenient position for manipulation by the hand of the operator. Depending from the end of each crank 2 is a link 3^a, whose lower end is connected to the lower end of a downward-extending crank 4, formed on the forward end of a rearward-extending rock-shaft 5. The rock-shafts 5 are parallel and are suitably journaled in the casing, and on the rear end of each of said shafts is formed a substantially horizontal crank 6. The outer end of each of these cranks is pivotally connected to the upper end of a vertical bar 7, which is formed of two sections. The lower section of each of these bars is tubular and is vertically and rotatably adjustable on the upper sec-

tion, the two sections being secured rigidly together by a set-screw 8. The tubular section of each bar 7 is provided near its lower end with a sleeve 9, between which and the guide 10 for the lower end of the rod is confined a coil-spring 11, which maintains said bar normally elevated.

Extending rearward from the sleeve 9 of each bar 7 is a tubular arm 13, which forms one section of the pedal-depressing arm. Slidingly adjustable in this tubular section is the other section of this arm, this latter section being provided at its rear end with the depending pedal-engaging foot 14, said foot carrying a cushion 15, which bears directly on the piano-pedal.

The operation of the device will be readily understood. By drawing forward either of the hand-engaging levers the shafts 1 and 5, controlled thereby, are rocked, the bar 7 depressed, and the connected pedal-depressing arm caused to force down one of the pedals of the piano. The spring 11 returns the parts to their normal position.

It will be noted that the hand-engaging device is connected positively to the pedal-depressing arm by non-elastic means, and the movement of the hand-engaging device is transmitted positively to the said arm. It will also be noted that as the section of the bar 7 carrying the pedal-depressing arm may be vertically adjusted and rotated and the pedal-depressing arm extended or shortened the device may be accurately adjusted to operate the pedals of pianos of different makes and sizes.

It is obvious that different arrangements of the rock-shafts and the hand-engaging means may be made, and I therefore do not wish to limit myself to the precise arrangement shown.

What I claim is—

1. In a mechanism of the class described, the combination of the casing, a pair of horizontal rock-shafts arranged within the casing parallel with the front thereof, hand-operating means for rocking said shafts, a pair of rearwardly-extending rock-shafts each having a connection at one end with one of the first-named rock-shafts, a pair of vertically-

arranged bars each having a connection with one of said rearwardly-extending rock-shafts, a pedal-depressing arm carried by each of said vertical bars, and means for yieldingly
5 maintaining said bars elevated.

2. In a pedal-operating mechanism, the combination of a casing, a vertical bar at the rear of said casing formed of two sections one of which telescopes within the other, means
10 for adjustably locking said sections one to the other, means for yieldingly maintaining said bar in an elevated position, a horizontal pedal-depressing arm formed of two telescoping sections one of which is secured to said vertical
15 bar, and means at the front of the casing for depressing said vertical bar, for the purpose specified.

3. In a pedal-operating mechanism, the combination of the casing, a horizontal rock-shaft within the casing parallel with the front thereof, a hand-engaging arm and a crank arranged respectively at opposite ends of said shaft, a rearwardly-extending rock-shaft having crank-arms at its opposite ends, a link
25 connection between the crank of the first-named rock-shaft and one of the cranks of the rearwardly-extending shaft, a vertically-movable bar at the rear of the casing having a connection at its upper end with the other
30 crank on the rearwardly-extending rock-shaft, a pedal-depressing arm carried by said vertically-movable bar, and a spring coiled about the lower end of said bar for normally holding the same elevated, substantially as described.

4. In a mechanism of the class described, the combination of a casing, a vertical bar at the rear of said casing formed of two sections which are adjustable vertically on each other, the lower section being rotatably adjustable
35 on the other, said bar being vertically movable, means for yieldingly maintaining said bar elevated, a horizontal pedal-depressing arm carried by the lower section of the vertical bar, a movable hand-engaging device at
40 the front of the casing, and means connecting said hand-engaging device to the vertical bar at the rear of the casing whereby the

movement of the hand-engaging device will depress said bar.

5. In a mechanism of the class described, 50 the combination of the casing, a pair of horizontal rock-shafts within said casing and at the front thereof, said shafts being parallel with the front of the casing, a vertically-extending hand-engaging arm at one end of 55 each of said shafts, a crank on the other end of each of said shafts, a pair of rearward-extending rock-shafts below the shafts of the hand-engaging arms, a crank on the forward end of each of said shafts, a depending link 60 connected to the end of each crank of the shafts of the hand-engaging arms, the other ends of these links being connected to the cranks on the forward ends of the rearward-extending shafts, a crank on the rear end of 65 each of these latter shafts, a depending bar connected to each of these cranks, a pedal-depressing arm carried by each of these bars, and means for yieldingly maintaining said bars elevated. 70

6. In a mechanism of the class described, the combination of a casing, a vertical bar at the rear of said casing and formed of two sections which are adjustable vertically on each other, the lower section being rotatably 75 adjustable on the other, said bar being vertically movable, a spring surrounding said bar and yieldingly maintaining said bar elevated, a horizontal pedal-depressing arm carried by the lower section of the vertical bar 80 and formed of two sections longitudinally adjustable upon each other, a depending pedal-engaging foot secured to the outer end of said pedal-depressing arm, a movable hand-engaging device at the front of the casing, 85 and means connecting said hand-engaging device to the vertical bar carrying the pedal-depressing arm.

In testimony whereof I affix my signature in presence of two witnesses.

THEODORE PARKER BROWN.

Witnesses:

H. L. PARKER,

HENRY L. PARKER, Jr.