

F. GIRARD.  
Electric Burglar-Alarm.

No. 112,585.

Patented March 14, 1871.

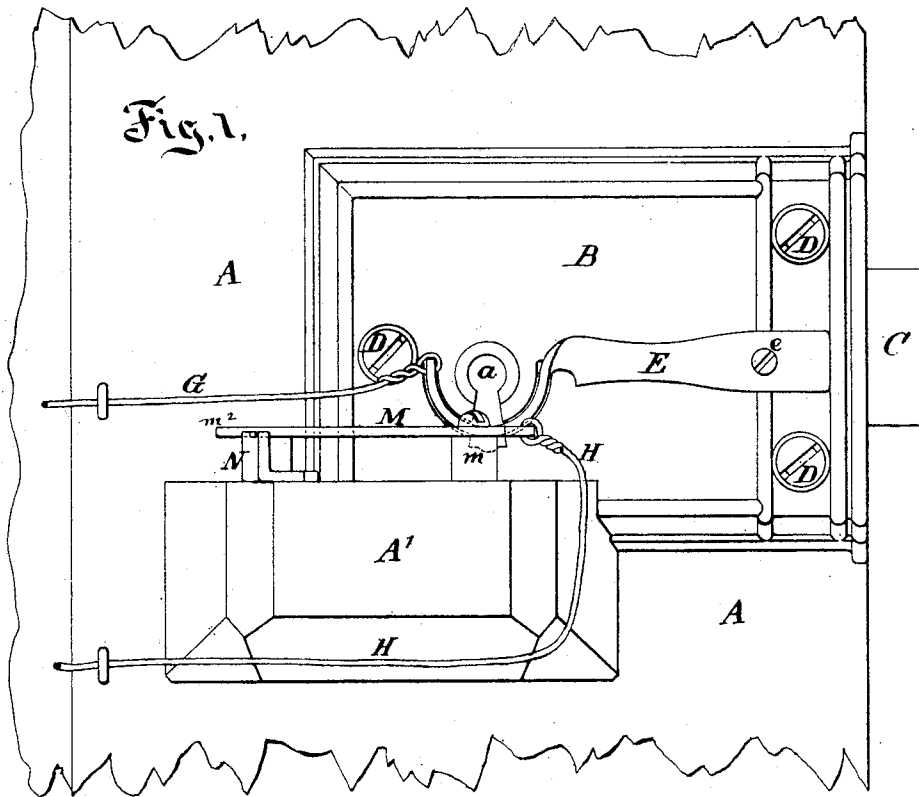
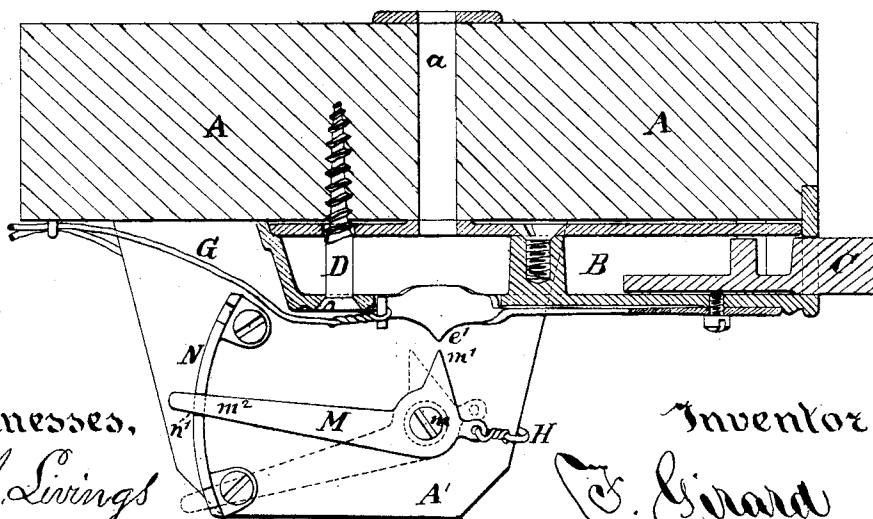

Fig. 2.



Witnesses,

C. C. Livings  
A. Hoermann

Inventor,

F. Girard  
by his attorney  
T. D. Eaton

# United States Patent Office.

FREJUS GIRARD, OF HAVANA, CUBA.

Letters Patent No. 112,585, dated March 14, 1871.

## IMPROVEMENT IN ELECTRICAL ALARM-LOCKS.

The Schedule referred to in these Letters Patent and making part of the same.

*To all whom it may concern :*

Be it known that I, FRÉJUS GIRARD, of the city of Havana, in the Island of Cuba, have invented certain new and useful Improvements in Alarm-Locks; and I do hereby declare the following is a full and exact description thereof.

My improved lock is intended more especially for use on the doors of dwellings, warehouses, &c., but it may be used on the doors of vault-safes, and, with proper care to protect and conceal the connections, on portable safes and strong boxes, and on the drawers of desks, bureaus, &c., when desired.

I will proceed to describe what I consider the best means of carrying out my invention.

The accompanying drawing forms a part of this specification.

Figure 1 is a view of the lock and its appurtenances attached to the outside door of a dwelling or warehouse, the view being from the interior of the building; and

Figure 2 is a horizontal section through the lock, with a plan view of the principal novel parts.

The strong lines in fig. 2 represent the lock adjusted for night service. In this condition it will give an alarm.

The dotted lines represent the parts adjusted for day service. In this condition no alarm will be given.

The drawing represents the novel parts, with so much of the ordinary parts as is necessary to indicate their relation thereto. The parts not represented may be of any ordinary or suitable character.

Similar letters of reference indicate like parts in both the figures.

A is the body of the door;

B is the fixed casing of the lock;

C is the bolt; and

D D are screws, which secure the lock firmly to the door.

E is a spring, curved in the form of a semicircle at its free end, and capable of moving outward and inward in a corresponding curved slot or aperture formed in the back plate of the lock. This spring is secured to the lock by the screw *e*, and is sufficiently flexible to be easily moved by the entrance of the key. On inserting the key through the key-hole *a* it strikes and pushes backward the spring E.

A wire, G, secured to the spring E, leads to the positive pole of a galvanic battery, not represented.

M is a lever, turning on a fixed point, *m*.

A wire, H, leads from this lever M to the negative pole of the battery above referred to.

The lever M is a bent lever, the two ends being indicated by *m*<sup>1</sup> *m*<sup>2</sup>. The end *m*<sup>1</sup> is reduced nearly to a point. There is a corresponding point or projecting surface on the back of the spring E, as indicated by

*e*'. When these points are placed as shown by the strong lines in fig. 2, the entrance of the key, by pushing back the spring E, will force the points *e*' and *m*<sup>1</sup> into contact and induce a current through the battery. This is the condition which is made to obtain in the night, or whenever it is desired that the lock shall give an alarm.

The other leg, *m*<sup>2</sup>, of the lever M is capable of being adjusted in notches in an arc, N.

The pin *m* and the arc N are secured on a block or inward extension, A', which is bolted or otherwise firmly fixed on the door A.

By applying the finger to the arm *m*<sup>2</sup>, and lifting it out of the notch in which it is represented by the strong lines in fig. 2, it may be readily moved into either of the other notches, and in that new position, the point *m*<sup>1</sup> is out of line with the point *e*', and the insertion of the key and the operating of it will not bring the points *e*' and *m*<sup>1</sup> into contact, and, consequently will not induce any current.

I have now shown the means whereby the entrance of the key is made to induce a current in one adjustment of the lock, and to be of no effect in another condition.

The provisions for inducing an alarm by means of a current are so common and so well known that I have not deemed it necessary to represent them.

Any of the ordinary provisions may be employed for inducing the current to maintain a continuous vibration of a hammer within a bell or otherwise to induce an alarm.

The wires G and H being insulated by any of the ordinary means, they may be led to any distance, so as to give the alarm in the bed-room of a watchman or janitor in the upper portion of the building, or at the house of the owner in a distant portion of the town, or at both these points.

It will be observed that the curved portion of the spring E has a bunch or cam on the side toward the key. This is so placed that the true key, or any false key or other instrument for operating the lock, cannot be inserted without touching this spring and forcing it back, so as to give an alarm.

I esteem it very important that the alarm shall be given on the insertion of the key. There have been inventions for giving an alarm by the opening of the door. This I esteem not sufficiently early. It is important to give the alarm, not by the opening of the door, or by the movement of the bolt, which is earlier, or by the movement of the key, which might in operations with false keys be frequently in advance of the movement of the bolt, but by the very act of insertion of the key or other implement.

I do not esteem it absolutely essential that the spring shall be curved in the form of a semicircle, as

shown, though this is preferable, because I can with this form prolong the bearing of the key thereon, or, by producing several bunches or cams thereon, cause it to move and release the spring several times during its turning movement. It may be made to serve with some success if straight. So, also, it may be arranged at the front of the lock—that is to say, between the lock and the door—and be pressed sidewise, instead of backward, by the entrance of the key. It is only essential that it be so placed that it be certain to operate and give the alarm, when properly adjusted, by the simple insertion of the key.

I claim—

1. The spring E, arranged as represented relatively

to the lock B C, and having connections, G H, to a battery, and to suitable alarm mechanism, so that the introduction of the key shall induce an alarm, substantially as set forth.

2. In combination with the above, the adjusting-lever M and its connections, by which the alarm may be thrown into and out of use, at pleasure.

In testimony whereof I have hereunto set my name in presence of two subscribing witnesses.

FREJUS GIRARD.

Witnesses:

JAMES PEYTON,  
JEAN LAFFONT.