

Dec. 25, 1923.

1,478,901

G. E. KING

SIGNAL DEVICE OPERATING MECHANISM

Filed Oct. 17, 1919

4 Sheets-Sheet 1

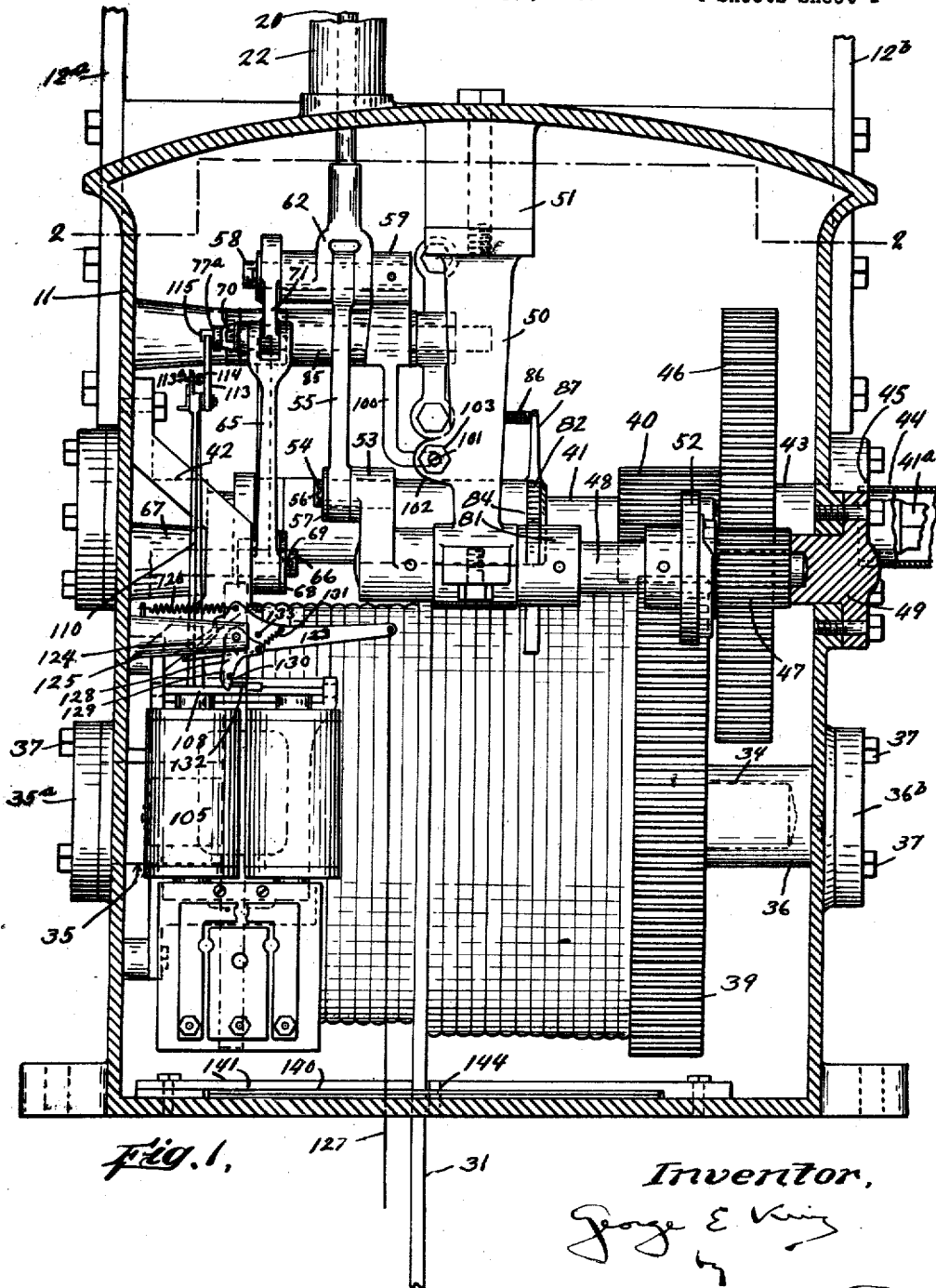

Fig. 1.

Inventor,
George E. King
[Signature]
att'y

Dec. 25, 1923.

G. E. KING

1,478,901

SIGNAL DEVICE OPERATING MECHANISM

Filed Oct. 17, 1919

4 Sheets-Sheet 2

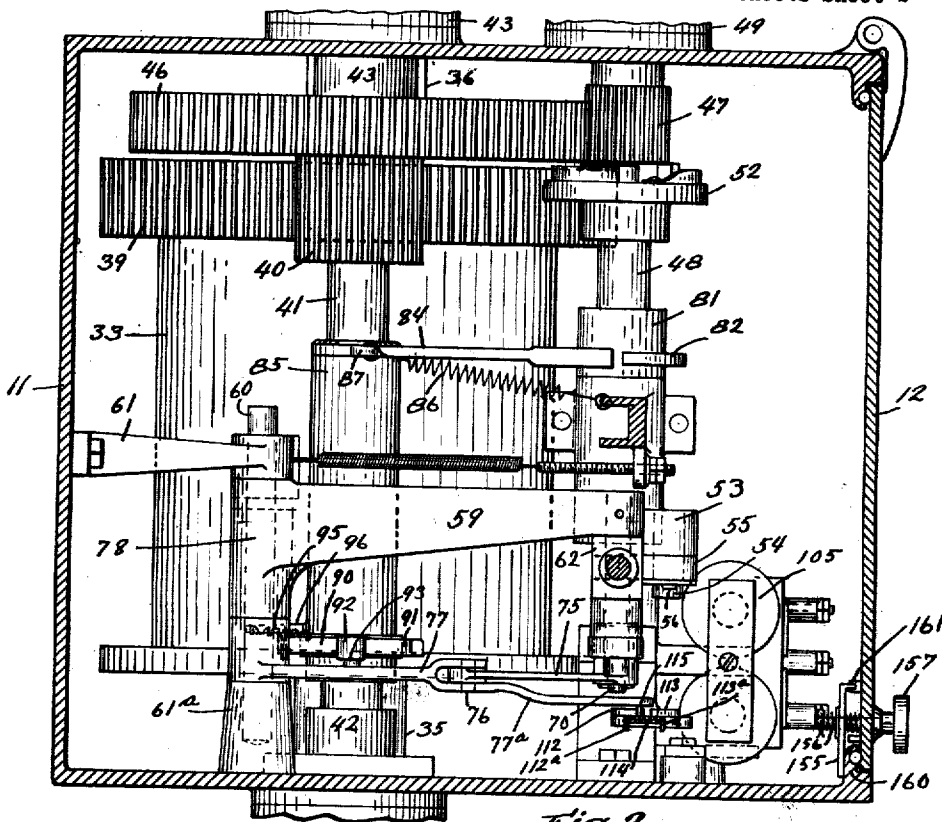

Fig. 2.

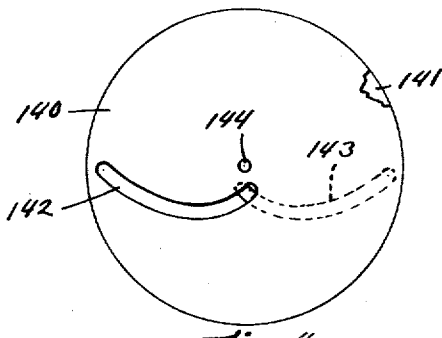

Fig. 4.

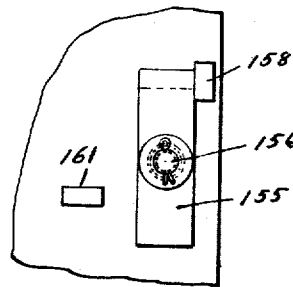

Fig. 5.

Inventor,
George E. King
T. J. Greenwood atty

Dec. 25, 1923.

G. E. KING

1,478,901

SIGNAL DEVICE OPERATING MECHANISM

Filed Oct. 17, 1919

4 Sheets-Sheet 3

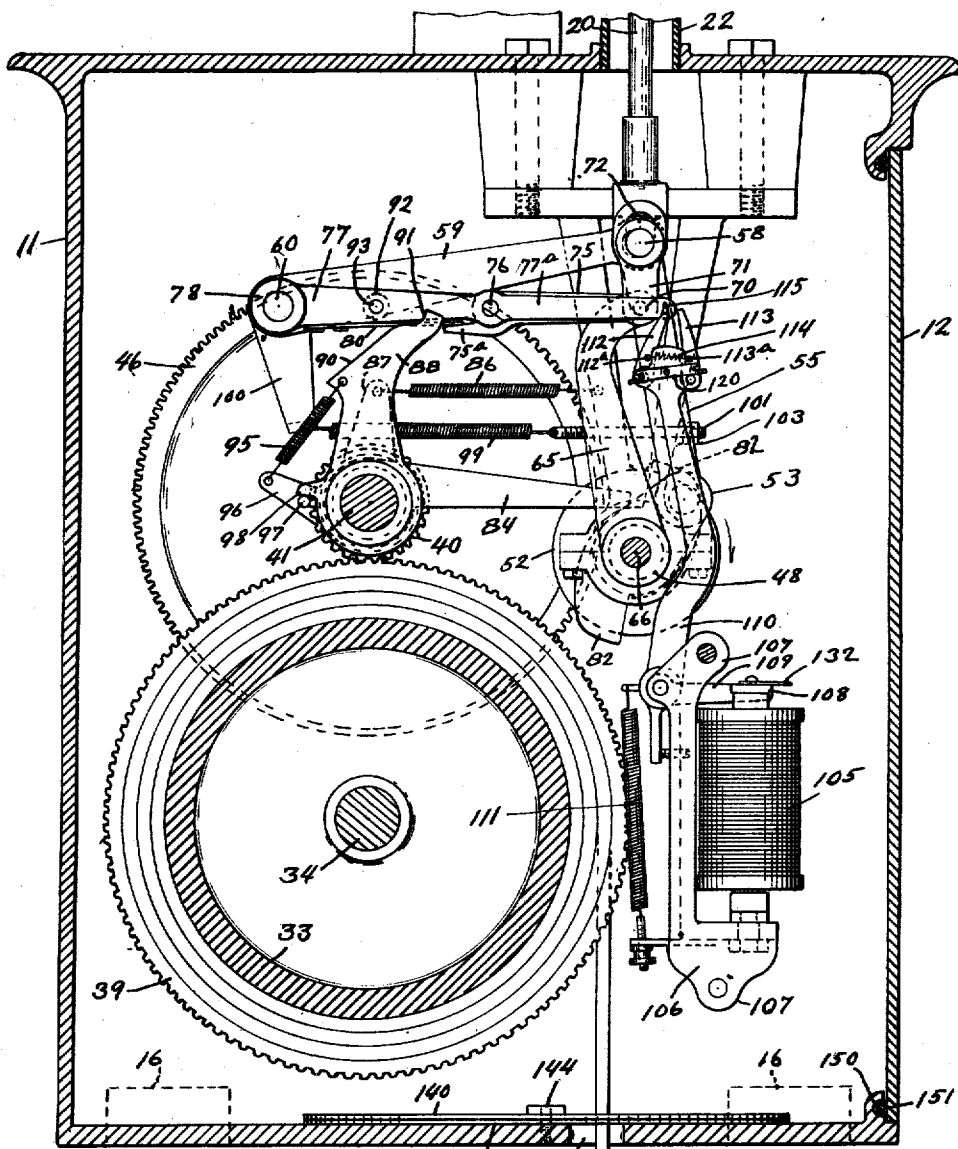

FIG. 3.

Inventor,

George E. King

Wm. Woodward atty

Dec. 25, 1923.

G. E. KING

1,478,901

SIGNAL DEVICE OPERATING MECHANISM

Filed Oct. 17, 1919

4 Sheets-Sheet 4

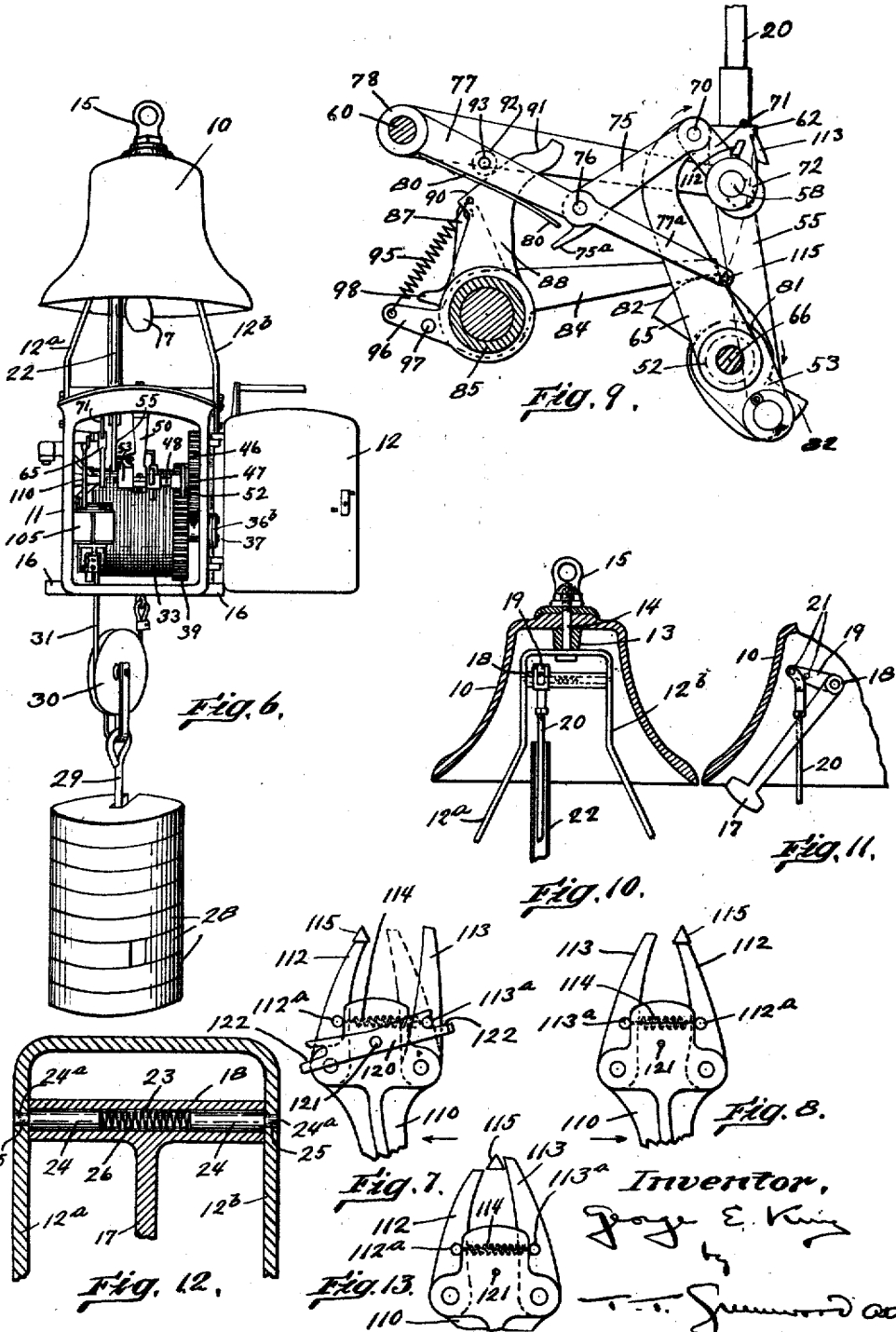

Inventor,
 G. E. King
 by
 J. S. Sumner atty

UNITED STATES PATENT OFFICE.

GEORGE E. KING, OF NEWTON, MASSACHUSETTS, ASSIGNOR TO THE GAMEWELL FIRE ALARM TELEGRAPH CO., OF NEWTON UPPER FALLS, MASSACHUSETTS, A CORPORATION OF NEW YORK.

SIGNAL-DEVICE-OPERATING MECHANISM.

Application filed October 17, 1919. Serial No. 331,401.

To all whom it may concern:

Be it known that I, GEORGE E. KING, a citizen of the United States, and a resident of Newton, in the county of Middlesex and State of Massachusetts, have invented an Improvement in Signal-Device-Operating Mechanism, of which the following is a specification.

This invention relates to signal or alarm devices and has more particular reference to bells designed to sound code signals, as for fog signals, fire alarms and the like, or to sound a continuous succession of signals.

An object of my invention is the provision of a signal or alarm device, as a bell, with operating mechanism assembled as a unit which is adapted either to be suspended from suitable supporting means, or supported on a pedestal.

The signal device operating mechanism, as above set forth, usually includes, as the source of power, a spring or weight motor; and the operation thereof is or may be remotely controlled over either a normally open or normally closed electric circuit.

A further object of my invention is the provision of an improved striking mechanism that is strong; that has a relatively small number of parts; that is adapted to sound either a single stroke or a continuous succession of strokes; that is adapted for operation, with but slight rearrangement of certain parts thereof, on either an open or closed circuit, and for either single stroke or continuous ringing; and that requires but a slight amount of energy to govern its operation.

Briefly, this object is attained by the provision of a weight driven crank-shaft operable to sound a stroke at each half revolution thereof and adapted to be locked at each half revolution by a toggle. The crank-shaft locking toggle is locked by a second toggle, the breaking or releasing of which is governed by an electro-magnet included in the controlling or signalling circuit. All toggles are adapted to be nearly in a straight line but slightly undershot in their locking position whereby but a slight amount of energy is required to re-

lease them, thereby to permit the operation of the mechanism; and power actuated toggle-resetting means are provided to positively reset the locking toggles.

The operation of the mechanism on either a closed or an open circuit is attained by the provision of two dogs or pawls which are interchangeable in position; and in one position adapts the mechanism to sound single strokes on open circuit, and in the other position, to sound single strokes on closed circuit. The continuous ringing on either circuit is attained by locking one of the pawls out of operative position.

A further object of my invention is to so arrange the unit that the striking mechanism is shielded against moisture and dirt.

A yet further object of my invention resides in improvements in the construction and operation of the device.

Fig. 1 is a front elevation of my improved striking mechanism, the front cover or door of the enclosing box being removed to more clearly show the location of the parts of the mechanism.

Fig. 2 is a plan view along lines 2-2 of Fig. 1, of the striking mechanism.

Fig. 3 is a side elevation of the striking mechanism partly in section.

Fig. 4 is a detail of the dust excluding plates.

Fig. 5 is a detail showing the cover or door locking device.

Fig. 6 is a front elevation of a complete signal device embodying my invention.

Fig. 7 is a detail showing the position of the pawls to ensure continuous ringing on a closed circuit signalling system.

Fig. 8 is a detail showing the position of the pawls to allow the striking mechanism to be operated or controlled over an open circuit.

Fig. 9 is a detail showing the striking mechanism.

Fig. 10 is a detail showing the manner of attaching the striking mechanism and carrying parts therefor, on the bell.

Fig. 11 is a detail showing the arrangement of mechanism to admit of the employment of bells of varying sizes.

Fig. 12 is an enlarged sectional detail of the bell striking hammer.

Fig. 13 is a detail illustrating the relation of the pawls and detent.

As here shown the unit includes the bell 10 and the mechanism enclosing box 11 having the cover 12. Said bell is supported above said box by the U-shaped member or bell frame having the spaced-apart arms 12^a and 12^b the ends of which are secured to the sides of the box 11. Said bell is secured to said frame, but spaced thereabove by the spacing block 13 to permit the undamped vibration of the bell by the bolt 14 which passes through said frame and block and is threaded into the eye-nut 15 by which the bell unit may be suspended from any suitable support. The box 11 is provided with feet 16 on each side thereof by which the unit may be secured to and supported by a pedestal; or both supporting methods may be employed, as desired.

The bell-striking hammer 17 is arranged within the bell and is integrally formed with the hub 18 which is pivotally disposed between the arms of said U-shaped member or frame at their substantially parallel portions whereby the hammer is free to be swung from one to the other side.

A crank-arm 19 is also integrally formed with said hub and extends therefrom for connection with the connecting rod 20 which extends downward into the box 11 for connection with the bell striking mechanism therein contained. Said crank-arm 19 has a plurality of holes 21 therein whereby said connecting rod may be connected therewith at various points to obtain varying sweeps of the bell hammer, the mechanism thereby being adapted to receive bells of varying sizes without other changes.

A tube 22 secured to the top of said box 11 encloses said connecting rod 20 and is of sufficient internal diameter to permit the unrestricted movement of said rod; and said tube extends for such a distance into the interior of the bell that the bell prevents the entrance of moisture or dust therein.

It is desirable, for various reasons, to remove the hammer from its operative position without removing the bell and the means which admits of this result is a feature of the invention. The hub 18 of said hammer 17 has an axial bore 23 therein in which the two similar pivot-pins 24 are arranged. Each pin has the reduced end-portion 24^a which is adapted to enter a recess or aperture 25 in the arms of said U-shaped member and a compression spring 26 arranged in said bore serves to force said pins apart and maintain them in said apertures in said U-shaped member. To remove the hammer, having first disconnected the connecting rod, it is merely necessary to press in said pins by suitable means to dis-

engage the hammer from said member. In replacing the hammer the arms 12^a and 12^b of the bell frame serve to press in the pivot pins and, when said hub is in alignment with the bearing apertures in the arms 70 thereof, said spring 26 forces the pins in place.

The power for operating the striking mechanism is obtained by the weights 28 removably arranged on the rod 29 suspended 75 beneath the box 11 on a pulley or sheave 30, and said pulley or sheave is hung in a loop of flexible cable 31, one end of which is secured to the under side of the box and the other end of which passes through a slot 80 32 in the bottom thereof and is passed about the cable drum 33 within said box and made fast thereto.

Said cable drum 33 is fixed to the shaft 34 which is journalled in the bearings 35 85 and 36 inserted through the opposite sides of the enclosing box and secured thereto by bolts 37 passing through the flanges 35^a and 36^b of said bearings. It is to be noted that said shaft 34, as also other shafts of the 90 mechanism, are of less length than the width of the interior of said box 11 whereby when the bearings thereof are withdrawn from the exterior of the casing the shafts, with their associated mechanism, may be 95 easily removed from the front of the box. The bearings are also closed at the ends and the flanges thereof are made a close fit with the box whereby the box is sealed against the entrance of moisture or dirt at these 100 points.

Said cable drum 33 has one end formed as a gear 39 which meshes with a pinion 40 fixed to a jack-shaft 41 journalled in bearings 42 and 43, and through the bearing 43 105 of which the squared end 41^a of said shaft projects for engagement by a suitable winding handle for the rewinding of the cable on the drum 33 to raise the weight 28 after the device has been repeatedly operated. A 110 cap 44 encloses said extended end 41^a of said jack shaft and is frictionally received in a recess 45 in said bearing 43 thereby to prevent entrance of dirt or moisture to said box 11 through said bearing. 115

A gear 46 is fixed to said jack-shaft 41 which meshes with a pinion 47 loosely arranged on the crank-shaft 48 which is journalled in the bearing 49 fixed in the side-wall of said box, and in the end of the hanger 50 secured to the lugs 51 depending from the top of said box. 120

Said pinion is provided with one half of an over-running clutch, the complementary component 52 of which is fixed to said 125 crank-shaft 48. By the use of this clutch the weights may be raised without operating the crank-shaft to cause the sounding of the bell.

A crank-arm 53 is fixed to that end of the 130

crank-shaft extended beyond the hanger 50 and has the wrist-pin 54 on which the crank end of a connecting-rod 55 is journalled and held in place thereon by the removable pin 56 and washer 57. The head end of said connecting rod is pivotally mounted on the pin 58 carried by the rocker-arm 59 loosely mounted on the pin or shaft 60 supported in the bracket 61 bolted to the rear wall of the enclosing box and hub 61^a formed on the side wall of the box. The lower end 62 of the bell connecting-rod is also pivotally connected to said pin 58 and said rocker-arm forms a guiding and supporting means for that end of said connecting-rod.

The striking mechanism is so constructed and arranged that the crank shaft is locked at each half-revolution thereof, after having sounded a stroke, and is locked slightly beyond dead center position, in which position the hammer 17 is clear of the bell to permit the undamped vibration thereof, and the mechanism is biased toward the next stroke. From the above it will be seen that the hammer 17 strikes opposite sides of the bell alternately at respective ends of its travel.

The mechanism locking means includes the link 65, curved to clear other components of the striking mechanism and pivoted at one end thereof to the stub-shaft 66 fixed in the hub 67 formed on a side wall of the box 11, and retained thereon by the washer 68 and removable pin 69. The other end of said link 65 is pivoted, by means of the pin 70, to a link 71 having an elongated slot 72 in the other end thereof in which is received the pin 58 on which both connecting rods are mounted. Said links 65 and 71 form members of a crank-shaft locking toggle adapted to lock the crank-shaft against rotation at approximately the top and bottom throws thereof, when the mechanism is arranged for single-stroke ringing. The position of the locking toggle with the crank-shaft locked at the top throw thereof is illustrated in Fig. 3, and Fig. 9 illustrates the position of the toggle members just after the crank-shaft has been released for operation and having been previously locked at the bottom throw thereof.

Said links 65 and 71 are adapted to lock the crank shaft against movement when the centers of pins 58, 70, 66 are about in line and when said link 71 is disposed above the link 65, as shown in Fig. 3, and also when said pins are in line and with the link 71 below the end of link 65, or with pin 58 between pins 70 and 66 and said link 71 will assume said two positions alternately to lock the crank shaft at each half revolution, when not otherwise controlled.

The crank-shaft locking toggle is adapted to be brought nearly into locking position by the crank-shaft during its movement, and finally moved into and held in locking posi-

tion, by means to be described, when the crank-shaft is at the extreme top and bottom throws thereof. By the provision of the slot 72 in link 71 of said toggle the crank-shaft is permitted such a movement, independent of said toggle, as to move the bell hammer 17 clear of the bell and bias the crank-shaft for movement on the next stroke.

The locking means for the crank-shaft locking toggle includes the link 75 pivoted at one end to the pin 70 connecting links 65 and 71, and at the other end to the pin 76 carried in the forked end of a link or arm 77 the end of which has formed thereon the hub 78 loosely mounted on the shaft or pin 60. Said links 75 and 77 form a locking toggle for the crank-shaft locking toggle.

Said link 75 is formed with an extension of lip 75^a which extends beneath said link or arm 77 to serve as a stop to prevent the overshooting of the toggle and said link or arm 77 bears a flat spring 80 secured to the under side thereof, the free and resilient end of which is interposed between said link or arm and the extension or lip 75^a for the purpose of assisting the mechanism to break the toggle to permit the operation of the striking mechanism upon the release of said arm 77 by means hereinafter to be described.

While the crank-shaft, during its movement, partially resets both locking toggles after the breaking thereof yet it cannot be relied upon to complete the resetting operations because of the extreme disadvantage under which the crank-shaft must operate, and therefore positive, power-actuated, toggle-resetting means are provided.

One of the elements of said means comprises the cam-wheel 81 fixed to said crank-shaft 48 and having the diametrically opposed cams 82 properly arranged with respect to the crank-arm of said crank-shaft and having gradually inclined working faces and abrupt release portions. Said cams are adapted to gradually raise and then release the arm 84 integrally formed with the extended hub 85 loosely journalled on the jack-shaft 41. Said arm is constantly pressed against said cams by the tensile spring 86 extended from the hanger 50 or other stationary part of the striking mechanism to an arm 87 integrally formed on said hub 85.

A cam-arm or toggle-resetting member 88 is loosely journalled on the end of said hub 85, being secured against unintentional displacement therefrom by suitable means, and has the cam-face 90 terminating in the hooked or cam-arm locking portion 91. Said cam-arm is arranged to engage a roller 92 carried on the end of a pin 93 fixed in said arm 77 thereby to raise said arm into a toggle-set position, as in Fig. 3. The hooked end-portion 91 is adapted to engage said roller

92 which, in the locked or set position of the toggle including the arm 77, will prevent further movement of said cam-arm; as otherwise said cam-arm may be moved beyond said roller and, upon the release of the toggle for the operation of the striking mechanism, the toggle members might prevent the return of said cam-arm.

Said cam-arm is connected to the hub 85 by the retractile spring 95 extended between said arm and an arm or ear 96 formed on said hub 85; and a pin 97 engageable with a projection 98 of said cam-arm limits the retractile effect of said spring.

The provision of the resilient connection between the cam-arm and hub 85 is desirable because otherwise the cams 82 must be very accurately designed to follow up the movement of the toggle members caused by the crank-shaft and reset the toggles at the proper point in the crank-shaft movement.

With the mechanism above described the bell will be given a greater impact upon the downward movement of the bell connecting-rod 20 than upon the upward movement thereof, due to the weight of the connecting-rod and other associated parts of the striking mechanism.

To neutralize this weight the retractile spring 99 is connected between the depending arm 100 formed on the rocker-arm 59 and the threaded rod 101 extended through an ear 102 of the hanger 50 and provided with the adjustable nut 103. By adjusting said nut to vary the tension of said spring 99 thereby substantially to balance the weight of the mechanism, both strokes of the hammer may be made perceptibly equal in effect.

The control of the striking mechanism is effected through the electro-magnet 105 adapted to be included in a signal circuit and governed from a remote point. Said electro-magnet is supported on the frame 106 having the ears 107 by which it is suitably secured to a side wall of the enclosing box. The armature 108 thereof is secured to the arm 109 of a bell-crank lever having the pawl-supporting arm 110 extended upwardly from said electro-magnet, and said lever is pivotally supported in said frame 106. An adjustable retractile spring 111 normally tends to retract the armature 108.

The pawl arm 110 has a short pawl 112 and a long pawl 113 both independently pivoted thereto by suitable pins 112^b and 113^b respectively. Pins 112^a and 113^a are carried by pawls 112 and 113, respectively, and a spring 114 connects said pins and, acting through them, draws the free ends of said pawls toward each other; the movement thereby imparted to said pawls being limited by the engagement of said pins with the arm 110.

The arm 77 of the locking toggle for the crank-shaft locking toggle is formed with

an extension 77^a in the end of which is arranged the detent 115 adapted, in the locked or set position of the toggle, to rest upon the flat top of one or the other of said pawls whereby said toggle is held in locked position and the striking mechanism restrained from operation.

If the unit is adapted for operation in a normally closed signal circuit, the armature 108 of said electro-magnet 105 will normally be held in an attracted position and the detent 115 is in contact with the top of the short pawl 112 and the toggles are held in locked position and the mechanism is restrained from operation. Upon the interruption of the signal circuit to send a signal impulse the electro-magnet 105 is deenergized and the pawl arm 110 is moved to the left, Fig. 3, and the pawl 112 is moved from under said detent 115 and the toggles are permitted to collapse, the detent passing between the pawls and the mechanism being operated to sound a stroke. The partial rotation of the crank-shaft operates the cam-arm 88 to restore the toggle to locked position and, if current through the signal circuit has not yet been established, due to the fact that the striking mechanism operates at a faster rate than the signalling mechanism of the circuit, the detent arm will yet be in the armature-retracted position; and the detent will engage the long pawl 113 in the restoring movement of said arm 77, and said arm will be held in the toggle-locked position. The completion of the signalling circuit will cause the attraction of the armature 108 of the electro-magnet and the long pawl 113 will be moved from under said detent, and the detent will drop onto the short pawl 112; the projected space between the top of said pawls being less than the width of the detent, yet the actual space between said pawls is such that the detent may pass therebetween from the short pawl for the operation of the striking mechanism. This arrangement is more clearly shown in Fig. 13.

To condition the mechanism for single stroke operation on a normally open signal circuit it is necessary merely to interchange the pawls on the pawl-arm as illustrated in Fig. 8. In this position, and with the armature 108 normally retracted, the detent rests upon the short pawl and when the circuit is completed for the sending of a signal the short pawl, as before, passes from beneath the detent and the toggles are thereby broken and the striking mechanism is operated to sound one stroke, and the toggles are positively restored as before, and the detent again rests upon either the long or the short pawl depending whether the circuit is yet complete or has been interrupted.

For continuous ringing on either a normally open or closed signal circuit after an

initial signal impulse a pawl locking member is provided, which comprises the lever 120 pivoted to the pawl-arm 110 at 121 and having the similar notched ends 122 each adapted to receive either the pin 112^a or the pin 113^a to which the pawl retractile spring 114 is connected, whereby the long pawl may be held out of engagement with said detent 115 as in Fig. 7 in either of its two interchangeable positions on said arm 55. It may be observed, moreover, that however these pawls may be assembled, if the pawl to the left of the lever 120, Fig. 3, is held in abnormal position, the striker will operate continuously while the armature is in attracted position; and if the pawl to the right of the lever 120 is abnormally positioned, the striker will operate continuously while the armature is in retracted position.

A lever 123 is pivotally arranged in a slot 124 in the boss 125 carried by a side-wall of the enclosing box 11. A retractile spring 126, extended between said lever and the box wall or the boss, normally serves to draw said lever into the position shown in Fig. 1. A cord 127 extends from the extremity of said lever through an opening in the bottom wall of the box to a convenient location for manual operation. A latch 128 having the depending arm 129 with the slot 130 therein is concentrically pivoted with said lever 123 to said boss 125 and connected to said lever through the light retractile spring 131. The armature 108 bears a flat strip 132 adapted to be received in said slot 130 of said latch in its retracted position for closed circuit operation, and in its attracted position for open circuit operation and thereby held from response to the electro-magnet 105. During such condition the armature will be locked whenever it moves to retracted position, until released by pulling the cord 127 so as to move the pin 133 carried by the lever 123 into engagement with the latch 128 and thereby disengage said latch from the strip 132 carried by the armature. When so locked, if the lever 120 is so positioned as to hold whichever of the pawls 112 and 113 as happens to be mounted to the right of the pawl arm 110, so that such pawl will be held out of the path of the detent 115 (as indicated by Fig. 7), the striker will operate continuously following deenergization of the magnet 105 until the latch 128 is withdrawn from the path of the strip 132 and said magnet is again energized, so that the continued operation of the striker after retraction of the armature will not be interrupted by subsequent energization of said magnet until said latch is actuated by pulling the cord 127. Correspondingly, if the pawl situated to the left of the pawl arm 110 (as viewed in Fig. 7) is abnormally positioned by engagement therewith of the lever 120—so as to afford continuous operation of the striker

while the armature is in attracted position—the notch 130 should be so situated as to receive the strip 132 when the armature is in attracted position; so that continued operation of the striker after movement of the armature to attracted position will not be interrupted by subsequent deenergization of the magnet until the latch 128 is actuated.

It is obvious that the lever 123 and latch 129 might be integrally formed, and serve the purpose, but in this event the retractile spring 126 must be very light as otherwise it would cause undue friction to the movement of the armature, and consequently the apparatus might fail properly to operate.

The lever 123 and associated mechanism is arranged as an attachment to the striking mechanism, for the reason that it is not always necessary, and consequently it may or may not be installed in the box, as desired. The use of this attachment is particularly desirable when the striking mechanism is arranged for continuous operation during abnormal conditioning of the signalling circuit, so that, in the event of unintended abnormal conditioning of said circuit for an extended time, due to some defect therein, the striking mechanism may be rendered unresponsive to said circuit, pending completion of repairs thereto.

As above stated the cable 31 passes through the slot 32 in the bottom of the box. To close said slot and yet permit the necessary transverse travel of the cable two discs 140 and 141 are provided, each having the complementary suitable curved slots 142 and 143 therein through which the cable is extended, and said discs are concentrically pivoted to the base of the box at 144. The slotted discs are arranged so that, as the cable is moved from one side to the other of the box, the slots 142 and 143 will cooperate to provide a small cable opening and one disc will cover the remainder of the slot of the other, and the slot 32 in the box-wall thereby in a great measure excluding dust and moisture from entrance to the box through said slot 32.

The front face of the box is formed with a groove 150 therein in which a continuous resilient packing strip or gasket 151 is received and against which the cover 12 is forced, thereby to seal the door opening.

The door is locked to the box by the locking member 155 threaded on the rod 156 extended through the door 12 and terminating in the knob 157. To open the door from the position shown in Fig. 2 the knob 157 is unscrewed and, when sufficiently loose, a further turning movement also turns the member 155 from the position shown to a position against the lug 158 formed on the interior of the door and the door may now be opened. To lock the door the knob is screwed up and the member 155 is rotated

under the ledge 160 of the box and against a second lug 161 of the door. A further screwing movement of the knob serves to draw the door tightly against the resilient packing strip 151.

It is obvious that modifications in the arrangement and design of the apparatus herein set forth may be made without departing from the spirit of my invention.

It is also obvious that the mechanism herein described may be employed without material alteration for the operation of signalling devices other than bells, by which a code or other signal is given.

I claim:

1. Operating mechanism for a signal device comprising a crank shaft, means to rotate said crank shaft, means to lock said crank shaft alternately in two positions including a toggle, and means to lock said toggle including a second toggle.

2. A signal device operating mechanism, including actuating means arranged for movement between two positions to operate the device, and locking means comprising a toggle and associated means so formed and arranged with relation to said actuating means as to be adapted to lock same alternately in said positions.

3. A signal device operating mechanism, including actuating means arranged for movement between two positions to operate the device, locking means including a toggle so formed and arranged with relation to said actuating means as to be adapted to lock same alternately in said positions, and locking means for said toggle.

4. A bell striker including a hammer, actuating means therefor arranged for movement between two positions to actuate said hammer, locking means including a toggle so formed and arranged with relation to said actuating means as to be adapted to lock same alternately in said positions, and a toggle to lock said first toggle.

5. A signal device operating mechanism, including actuating means arranged for movement between two positions to operate the device, locking means including a toggle so formed and arranged with relation to said actuating means as to be adapted to lock same alternately in said positions, a toggle to lock said first toggle, and locking means for said second toggle.

6. A bell striker including a hammer, actuating means therefor arranged for movement between two positions to actuate said hammer, locking means including a toggle so formed and arranged with relation to said actuating means as to be adapted to lock same alternately in said positions, a toggle to lock said first toggle, and locking and releasing means for said second toggle.

7. A signal device operating mechanism including a crank shaft, driving means

therefor, and means comprising a toggle and associated means so formed and arranged with relation to said crank shaft as to be adapted to lock same at each half-revolution thereof.

8. A bell striker including a hammer, a crank-shaft, driving means therefor, means operatively connecting said hammer and crank-shaft, means including a toggle so formed and arranged with relation to said crank-shaft as to be adapted to lock same at each half-revolution thereof, and locking means for the aforesaid means arranged to release said crank-shaft for operation.

9. A signal device operating mechanism including an operating member, actuating means for said member comprising a connecting rod, driving means for said connecting rod comprising a crank-shaft, locking means for said member comprising a toggle connected therewith, restoring means for said locking means including a reciprocable cam-member arranged to engage said toggle and move it toward reset position and operating means for said restoring means operably connected with said crank shaft.

10. A bell striker including actuating means, a locking toggle having a link connected with said actuating means and arranged to release said means for its operation, said actuating means having a member arranged to engage and partially restore said locking toggle, and other means arranged to complete the restoration thereof.

11. A bell striker including actuating means, power-driven means for operating said actuating means, a locking toggle having a link connected with said actuating means and arranged to release said means for operation, said actuating means having a member arranged to engage and partially restore said locking toggle, and locking toggle restoring means operated by said power-driven means.

12. A bell striker including rotatable actuating means adapted to be locked releasably in a predetermined position against rotation, driving means for it, locking means for said actuating means comprising a double toggle adapted to release said actuating means for operation, and means to reset said locking means before said actuating means has arrived at locking position comprising a pivoted cam member releasably engageable with one of said toggles, and means operatively connecting said cam member with said rotatable actuating means for the resetting operation.

13. A bell striker including a crank shaft adapted to be locked releasably in a predetermined position, driving means for said crank shaft, locking means including a toggle arranged to lock said crank-shaft substantially off-center at its top and bottom positions, and restoring means for said lock-

70

75

80

85

90

95

100

105

110

115

120

125

130

ing means arranged for actuation by said crank shaft.

14. A signal device operating mechanism including a crank shaft, power driving means for said crank-shaft, a locking toggle for said crank-shaft, and connecting means including a lost motion connection between said toggle and crank-shaft, said means so formed and arranged as to permit rotation of said crank-shaft beyond top center position and the locking of said shaft against rotation at one side of said position.

15. A bell striker including a crank-shaft, adapted for uni-directional rotation driving means therefor, a locking toggle therefor biased toward unlocking condition, a locking toggle for the aforesaid toggle biased toward unlocking condition, and holding and releasing means for said second toggle.

16. A bell striker including actuating means, locking means for said actuating means including a toggle having two members, one of said members having a lip extended over and arranged in the path of movement of said other member, said other member having a spring engageable with the lip, and holding and releasing means for said toggle.

17. A bell striker including a rocker-arm, a hammer-connecting rod pivotally connected to said rocker-arm, a crank-shaft, a connecting-rod directly connecting said crank-shaft and rocker-arm, power-driving means for said crank-shaft, and locking and releasing means for said crank-shaft.

18. A bell striker including a hammer, a crank-shaft, means including a connecting-rod directly connecting said hammer and crank-shaft, guiding means comprising a rocker-arm pivoted to said connecting means, power driving means for said crank-shaft, and locking and releasing means for said crank-shaft.

19. A signal device operating mechanism including actuating means, comprising a rotatable crank-shaft, power-driving means for said actuating means, a toggle constructed and arranged to be set to lock said actuating means and broken to release said actuating means, and means associated with said toggle and crank-shaft constructed and arranged for operation by said crank shaft to reset said toggle to a locking condition.

20. A signal device operating mechanism including actuating means, locking and releasing means therefor including a toggle, a cam-arm engageable with said toggle in its unlocking condition for its restoration, and means operatively connecting said cam-arm with said actuating means.

21. A bell striker including actuating means, locking and releasing means therefor including a toggle, a cam-arm engageable with said toggle in its unlocking condition for its restoration, and yielding means oper-

atively connecting said cam-arm with said actuating means.

22. A bell striker including actuating means, locking and releasing means therefor including a toggle, a cam-arm engageable with said toggle in its unlocking condition for its restoration having means also engageable with said toggle to limit the movement of said cam-arm, and resilient means operatively connecting said cam-arm with said actuating means.

23. A bell striker including a crank-shaft, means comprising a double toggle for locking said shaft in and releasing it from a plurality of positions, restoring means for said locking and releasing means, comprising a pivoted cam member releasably engageable with one of said toggles, and a cam-wheel for operating said restoring means having a plurality of cam surfaces corresponding with the plurality of locking positions of said crank-shaft.

24. A bell striker including actuating means, locking and releasing means for said actuating means including a detent lever, a pawl arm, a long and a short pawl pivotally carried by said arm and engageable with said detent lever, said arm arranged to interchangeably receive said pawls, whereby the relation between said long and short pawls with respect to said detent lever may be varied.

25. A bell striker including actuating means, locking and releasing means for said actuating means including a detent lever, a pawl arm, two pawls carried thereby engageable with said detent lever, and means to lock one of said pawls out of operative engagement with said detent lever.

26. A bell striker including actuating means, locking and releasing means for said actuating means including a detent lever, a pawl arm movable from one to the other of two extreme positions, and two pawls pivotally secured to said arm and so positioned that one or the other of said pawls will be disposed in the path of said lever according to the positioning of said arm in one or the other of its said positions, such pawls so proportioned and arranged relative to one another and to said lever that, when said lever is restrained by engagement thereof with one of said pawls, movement of said arm to withdraw such pawl from the path of said lever will position the other one of said pawls to correspondingly restrain said lever, and means to lock one of said pawls out of operative engagement with said detent lever in any position it may occupy on said detent lever.

27. A bell striker including actuating means, locking and releasing means for said actuating means including a detent lever, a pawl arm, two pawls carried thereby engageable with said detent lever, and a lever

pivotaly carried by said pawl arm engageable with said pawls to lock them out of operative engagement with said detent lever.

28. A signal device operating mechanism including actuating means, driving means for said actuating means, locking and releasing means for said actuating means arranged normally to effect a single cycle of operation of said actuating means, electrically controlled means to cause the operation of the actuating means, and means to disable said locking and releasing means to permit a plurality of cycles of operation of the actuating means.

29. A signal device operating mechanism including actuating means having a definite cycle of action and driving means for said actuating means, in combination with locking and releasing means, also having a cycle of action and so arranged as to be adapted to release said actuating means for a single cycle of the action thereof during each cycle of said third named means, electrically controlled means for governing the action of said third named means, and means for adjusting said third named means to so limit its effectiveness for locking said actuating means as to permit a plurality of the cycles of said actuating means during a cycle of said third named means.

30. A bell striker including actuating means, driving means for said actuating

means, locking and releasing means for said actuating means arranged normally to effect a single cycle of operation of said actuating means, electrically controlled means to cause the operation of the actuating means, means to disable said locking and releasing means to permit a plurality of cycles of operation of the actuating means, and manual means to restore said locking and releasing means to its original condition.

31. Signalling mechanism including actuating means, driving means for said actuating means adapted to drive said actuating means continuously, locking and releasing means for said actuating means constructed and arranged normally to effect a single cycle of operation of said actuating means, means associated with said locking and releasing means arranged to effect the continuous operation of said actuating means, an electro-magnet having an armature governing the operation of said locking and releasing means, and means to stop the continuous operation of said actuating means comprising a locking device associated with said armature and arranged to hold it against operation, and manually-controlled means to govern said locking device.

In testimony whereof, I have signed my name to this specification.

GEORGE E. KING.