

(No Model.)

4 Sheets—Sheet 1.

J. H. MILLS.  
SECTIONAL BOILER.

No. 400,243.

Patented Mar. 26, 1889.

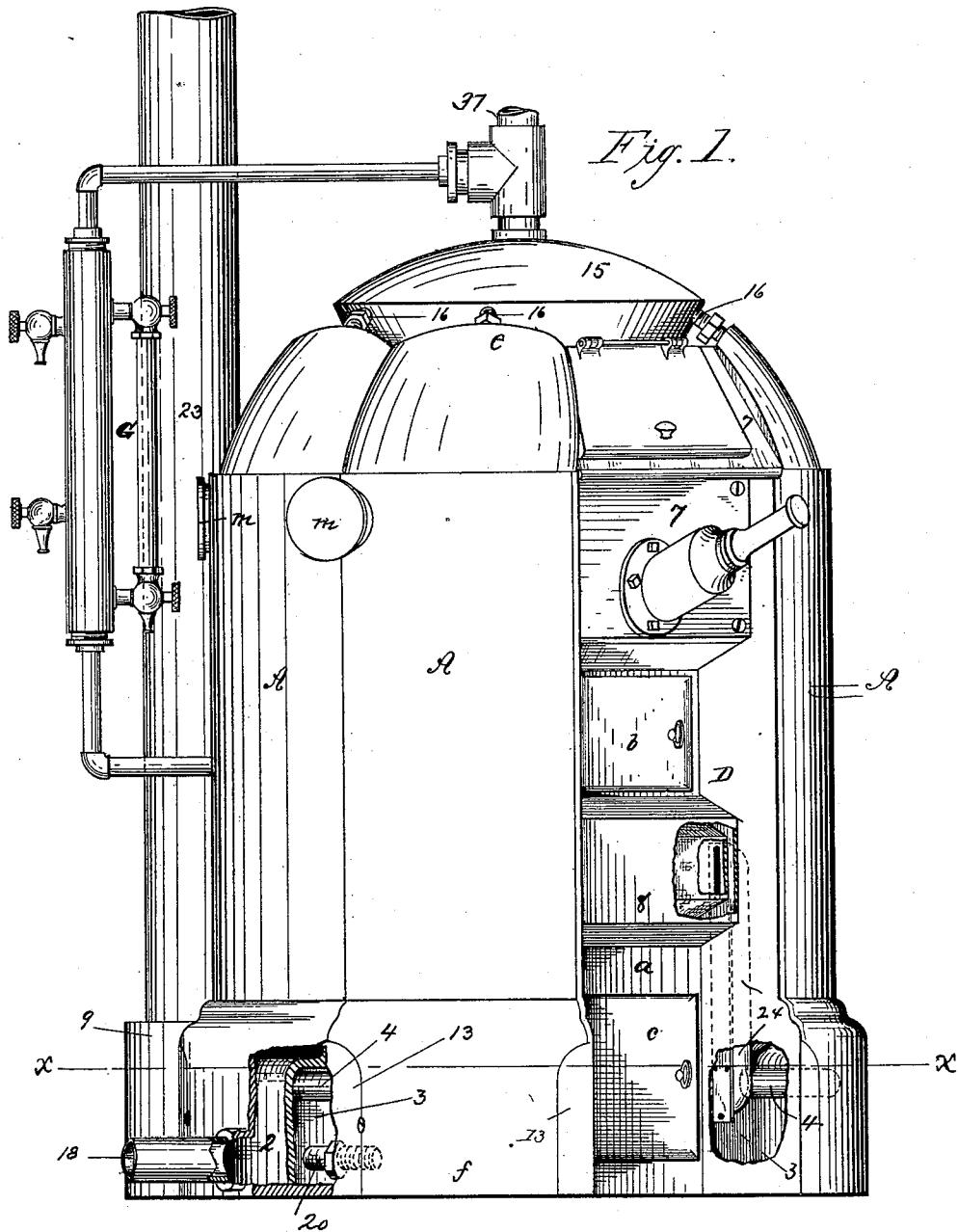

Witnesses  
*Wm. H. Chapin*  
*Wm. J. Bellamy*

Inventor  
*John H. Mills*  
By his Attorneys *Chapin & Co.*

(No Model.)

4 Sheets—Sheet 2.

J. H. MILLS.  
SECTIONAL BOILER.

No. 400,243.

Patented Mar. 26, 1889.

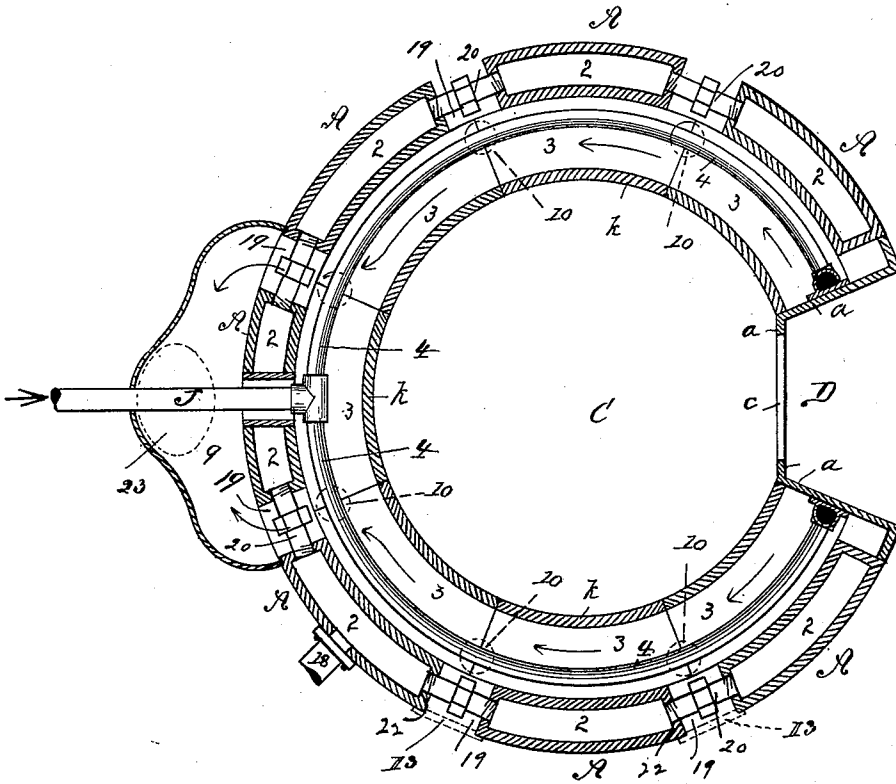

Fig. 2.

Witnesses

*Wm H. Chapin*

*Wm J. Bellamy*

Inventor

*John H. Mills*

By his Attorneys

*Chapin & Co*



J. H. MILLS.  
SECTIONAL BOILER.

No. 400,243.

Patented Mar. 26, 1889.

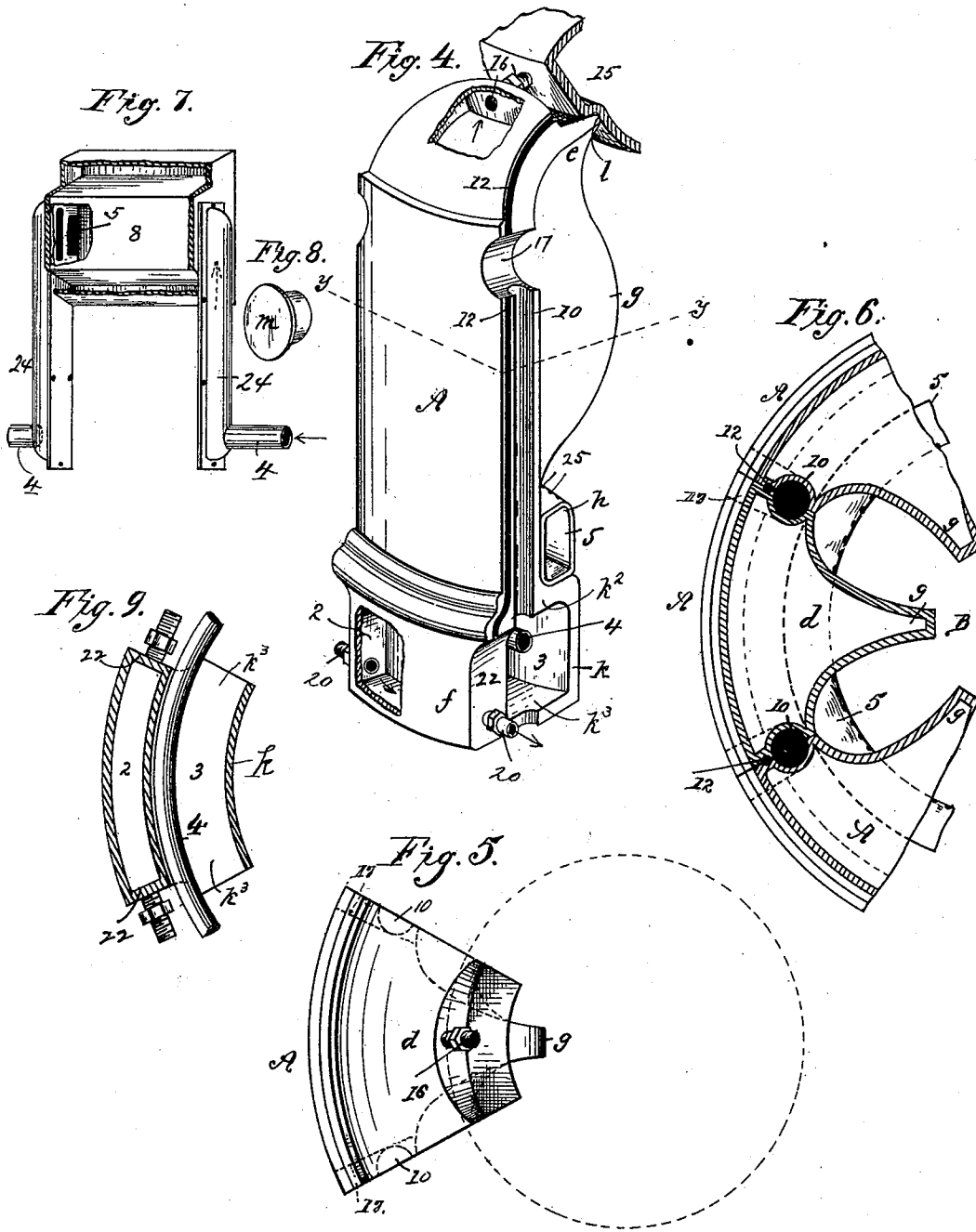

Witnesses  
*Wm. H. Chapin*  
*Wm. J. Bellows*

Inventor  
*John H. Mills*  
 By his Attorneys *Chapin & Co.*

# UNITED STATES PATENT OFFICE.

JOHN H. MILLS, OF BOSTON, MASSACHUSETTS.

## SECTIONAL BOILER.

SPECIFICATION forming part of Letters Patent No. 400,243, dated March 26, 1889.

Application filed June 16, 1888. Serial No. 277,357. (No model.)

*To all whom it may concern:*

Be it known that I, JOHN H. MILLS, a citizen of the United States, residing at Boston, in the county of Suffolk and State of Massachusetts, have invented new and useful Improvements in Sectional Boilers, of which the following is a specification.

This invention relates to boilers for warming buildings, either by steam or water circulation, the object being to provide an improved boiler of the sectional class for the above-named purpose; and the invention consists in the peculiar construction and arrangement of the sectional portions of the boiler, together with the steam-drum thereof, and means for producing a perfect combustion of the fuel and for distributing the products of combustion throughout the boiler, all as hereinafter fully described, and pointed out in the claims.

In the drawings forming part of this specification, Figure 1 is an elevation of a sectional boiler embodying my improvements, portions of the base of two sections being shown broken away. Fig. 2 is a transverse section through the base of the boiler on line *xx*, Fig. 1. Fig. 3 is a side elevation of two of the boiler-sections and steam-drum, together with the grate, the fuel-magazine and its operating devices, said figure showing the air or gas distributing box in section. Fig. 4 is a perspective view of one of the boiler-sections, showing portions of its wall broken away, and a portion of the steam-drum connected thereto. Fig. 5 is a plan view of one of the boiler-sections. Fig. 6 is a cross-section substantially on line *yy*, Fig. 4, but including parts of two adjoining sections. Fig. 7 is a perspective view of the air or gas distributing box and its connections. Fig. 8 is a perspective view of one of the closing flue-caps. Fig. 9 is a transverse section through the base of one of the boiler-sections, substantially on the same line that Fig. 2 is taken.

In the drawings, A indicates the sections of the boiler, said sections being made, preferably, by casting and coring out in the manner well known to iron-founders. Said sections are to be of any number, as desired, there being shown in the present instance seven thereof in circular arrangement around the combustion-chamber B and ash-pit C of

the apparatus, and each section is of a height equal to that of the boiler. As will be seen in Figs. 1 and 2, a space, D, is left between two of the sections at the front of the boiler, which is properly partitioned, as at *a*, through which are formed door-openings *b c*, leading to the combustion-chamber and ash-pit, and also permits of the disposition above the door *b* of a bin or receptacle, 7, for receiving comminuted or other fuel, which bin is also extended inwardly over the grate 6, and is to be provided with a mechanism for securing an automatic or other feed of the fuel into the combustion-chamber, which bin or fuel-box and mechanism constitute the subject-matter of a separate application for Letters Patent, filed June 16, 1888, Serial No. 277,358.

Each section A comprises an inclosed water-receptacle chamber, *d*, extending from its top *e* to its bottom *f*, and of varying widths radially in relation to the common center of the combustion-chamber at different heights thereof, its upper and vertically-central portion above the grate being inwardly extended, as at *g*, Figs. 3, 4, 5, and 6, and downwardly extended therefrom and in direct communication therewith to the bottom in a contracted hollow leg, as seen at 2, Figs. 1, 2, 3, 4, and 9, and as will be noted on reference to the cross-sectional contour of said central portions, *g*, of all the sections around and above the combustion-chamber they are inwardly converging, whereby the volume of the inclosed water is reduced and greater heat-impinging surface is secured; also comprised in each section A, at the portion of its height which is a little above the position of the grate, is one section, *h*, of a circular conduit or box, 5, to be hereinafter referred to; and also at the bottom of the section its walls are supplemented by inwardly-extending horizontal walls *k<sup>2</sup> k<sup>3</sup>* and the vertical partition-wall *k*, to form the section of a horizontal base exit, draft, and smoke-flue, 3, inside of the lower legs, 2, the said walls of said base-flue sections being open at their ends, so that when the several boiler-sections A comprising them are secured in place the continuous circular passage 3 will be formed, as seen in Fig. 2. When the sections are in place, their upper converging ends form in the top of the boiler a circular open-

ing, *l*, in which rests a drum, 15, and between the top of each section-chamber and the interior of the drum 15 communication is had by the tubes or nipples 16, exteriorly screw-threaded at their ends and screwing through the walls of the said sections and drum, serving also to confine the drum 15 and maintain the upper ends of the boiler-sections in place.

Near the top of each section in the abutting edges thereof, as will be seen in Figs. 3, 4, and 5, are two radially-extending semicircular openings, 17, extending from the inner to the outer wall, and extending vertically and downwardly from said openings 17, terminating in the circular flue-passage 3, are semicircular depressions, all so arranged that when the edges of two sections A are abutted a radial opening is formed through the walls of the boiler, and a vertical smoke-flue, 10, is formed extending therefrom to the said flue 3, the same being shown or indicated in Figs. 2, 3, 4, 5, and 6. The outer end of each radial opening 17 is to be closed by a stopper or plate, *m*, or, if preferred, the outer inclosing-wall for the opening 17 may be made integral with the outer wall of the section A. There are also coinciding vertically-disposed grooves 12 in the edge walls of the sections, so that when the sections are in place, the one against the other, a suitable packing material placed in said grooves will enable a tight jointing of the sections to be made.

The opposing edge walls 22 of the lower water-legs, 2, of each section are inwardly deflected, so that when the sections are set up ports or openings 19 are formed, leading to the base or smoke-exit flue 3, whereby to clear same of ashes, &c., when desired, removable closing plates or doors being provided for said openings, as indicated at 13, Figs. 1 and 2.

Water circulation between the lower chambered portions, 2, of the adjacent sections is provided for by means of the screw-threaded nipples 20, entered through the said edge walls 22 of the said sections, the said lower series of screw-threaded nipples also serving to confine the lower portions of the boiler-sections in place.

9 represents a smoke-box at the bottom of the furnace, at one side thereof, with which one or more of the openings 19 from the smoke-flue 3 communicate, and a vertical smoke-pipe, 23, is provided to lead away from said smoke-box.

J represents a horizontal inlet-pipe leading through the walls of one of the sections A and is shown as being entered at the place of and through the smoke-box 9, and said pipe is coupled for direct communication with a particular pipe, 4, horizontally disposed in the base-flue 3, and at the forward and nearly meeting ends of said pipe 4 riser-conductors 24 are connected, which lead to and form communication with an enlarged distributing-box, 8, at or about the level of the horizontal cir-

cular conduit or box 5, and with which conduit 5 said riser-conductors are in communication. Said conduit or box 5 is to be preferably formed of a refractory material—such as is used in making fire-brick or crucibles—and is to be perforated in suitable lines or arrangement, as at 25, so as to permit the emission therefrom of air or gas entered therein under suitable pressure somewhat above the top of the grate. The box 8 may be dispensed with and the vertical conductors 24 made to communicate directly with the conduit; but to provide an enlarged box to secure an increased volume of air in advance of the conduit 5 in practice is advantageous.

37 represents a supply-conduit leading to the radiators or other apparatus in the circulation, and 18 represents a pipe for conducting the returned and cooler water again to the boiler-sections, entering one thereof at its lower water-space, 2.

With a quantity of coal in combustion on the grate, being supplied regularly in a comminuted condition, the course of the primary draft is first through the ash-pit door, to and through the grate and combustion-chamber, to and through the various radial passages 17 and vertical intersectional flues 10, and to and into the base-flue 3, from which it issues to and through the smoke-box 9 and pipe 23. Air or gas under suitable pressure is also entered through the pipes J and 4, and is conducted vertically through the passages 24, into and through the distributing-box to and into the circular air-conduit 5, issuing therefrom through the perforations 25 in circular distribution at or above the top of the burning fuel, such supplemental draft aiding combustion in a large degree, securing a more perfect consumption of the fuel, and largely increasing heating effects at the expenditure of a minimum quantity of fuel. Exit is had for draft introduced into the combustion-chamber, as just described, through the passages hereinbefore described for the primary draft. Water being introduced through a suitable pipe into the lower portion, 2, of any one boiler-section, through the connecting-nipples 20, is distributed throughout the entire series of sections, and is to be usually supplied in such quantities as will maintain the boiler-sections and the drum 15 full, and the course of the circulation always being upward, the hot water will be carried through the pipe 37 to the radiators, a continuous circulation being maintained, the return and cooler water from the radiators being entered by the said pipe 18 into the lower space, 2, of one of the sections. By maintaining the water in the boiler-sections at a reduced level, so there is an unfilled space at the top portions thereof, more or less below the drum 15, a steam circulation may be established without any change in the apparatus, and, if desired, instead of employing comminuted fuel material for securing a combustion and heat, and supplying air

thereto, above the volume thereof; through the perforated conduit 5, gas may be entered into and issue from said conduit for combustion in the chamber B, the apparatus described being, as plain, susceptible of the various uses set forth.

G represents a transparent indicator or gage of common construction to be applied on the boiler in a usual manner to indicate the height of water therein.

What I claim as my invention is—

1. The combination, with a series of chambered boiler-sections arranged and joined together to form an inclosed combustion-chamber and having a direct water communication the one with the other, of a common receiver-drum having communicating-passages leading therefrom to the upper portion of each boiler-section, substantially as described.

2. The combination, with a series of chambered boiler-sections arranged and joined together to form an inclosed combustion-chamber, each of said sections being intermediate of its height formed with an inwardly-extended portion which is, transversely, inwardly converging, and said sections having a direct water communication the one with the other, of a common receiver-drum, having communicating-passages leading therefrom to the upper portion of each boiler-section, substantially as described.

3. The combination, with a series of chambered boiler-sections, A, arranged and joined together to form an inclosed combustion-chamber and having water communication with each other at their lower ends, of a common receiver-drum, 15, resting on the top of said sections and having water communications between it and the upper ends of said sections, substantially as described.

4. A series of boiler-sections arranged and joined together to form an inclosed combustion-chamber and having a direct water communication the one with the other, a grate supported in said combustion-chamber, the radial flues 17, the base-flue 3, in communication with a smoke-pipe, and vertical flues between said radial and base flues, combined with a common receiver-drum having communicating-passages leading therefrom to the upper portion of each boiler-section, substantially as described.

5. A series of chambered boiler-sections, each formed at its lower portion with its water-space of contracted width, as at 2, and having the additional integral partition-walls  $k$ ,  $k^2$ , and  $k^3$ , open at their ends inside thereof, and said sections having formed in adjacent edges at their upper portions the radial recesses 17 and vertical recesses from said radial recesses to and through said wall  $k^2$ , said sections being arranged and joined together to form an inclosed combustion-chamber, a circular base-flue, 3, radial flues and vertical flues 10 between and in communication with said radial and base flues, and stop-

pers closing the outer ends of said radial flues, and the nipples 20, connecting and forming communication between said chambered sections at the lower portions thereof, in combination with the common drum 15 at the top of said sections, and the nipples 16, connecting the upper end of each of said sections and said drum, substantially as described.

6. A sectional boiler consisting of a series of chambered boiler-sections arranged and joined together to form an inclosed combustion-chamber and having a direct water communication the one with the other, and having formed therein the radial flues 17, the base-flue 3, and a smoke-pipe in communication with said base-flue, and vertical flues 10 between said radial and base flues, the circular perforated conduit 5, an air-pipe leading thereto, and the common drum 15, having communicating-passages leading therefrom to the upper portion of each boiler-section, substantially as described.

7. A sectional boiler consisting of a series of chambered boiler-sections arranged and joined together to form an inclosed combustion-chamber and having a direct water communication the one with the other, and having formed therein the radial flues 17, the base-flue 3, and vertical flues 10 between said radial and base flues, the circular perforated conduit 5, the distributing-box 8, with which said conduit communicates, an air-pipe leading to said distributing-box, and the common drum 15, having communicating-passages leading therefrom to the upper portion of each boiler-section, substantially as described.

8. A sectional boiler consisting of a series of boiler-sections arranged and joined together to form an inclosed combustion-chamber and having a direct water communication the one with the other, the radial flues 17, the base-flue 3 in communication with a smoke-pipe, the vertical flues between radial and base flues, a grate supported in said combustion-chamber, the perforated circular conduit 5, formed of the arc-sections  $h$ , joined to said boiler-sections, the distributing-box 8, with which said conduit 5 communicates, the circular pipe 4, disposed in the base-flue, the pipe J, leading thereto, and the vertical passages 24, connecting said pipe 4 and distributing-box, substantially as described.

9. A sectional boiler consisting of a series of chambered boiler-sections formed, joined, and arranged together to form an inclosed combustion-chamber, base-flue 3, radial flues 17, and vertical flues 10, and the circular perforated air-conduit 5, substantially as described, said chambers having a direct water communication the one with the other, of a smoke-pipe connected with said base-flue, a distributing-box, 8, with which said circular conduit 5 is connected, the circular pipe 4, disposed within the base-flue, the air-inlet pipe J, leading thereto, the vertical passages

24, connecting said pipe 4 with said distrib-  
uting-box, the grate supported in said com-  
bustion-chamber below said perforated con-  
duit 5, the common drum having communi-  
5 cating-passages leading therefrom to the up-  
per portion of each boiler-section, the pipe 37,  
leading from said drum, and the return-pipe

18, leading into the lower portion of one of  
the said boiler-sections, substantially as de-  
scribed.

JOHN H. MILLS.

Witnesses:

WM. S. BELLOWS,  
G. M. CHAMBERLAIN.