



(86) **Date de dépôt PCT/PCT Filing Date:** 2014/01/28
 (87) **Date publication PCT/PCT Publication Date:** 2014/08/14
 (85) **Entrée phase nationale/National Entry:** 2015/08/06
 (86) **N° demande PCT/PCT Application No.:** US 2014/013416
 (87) **N° publication PCT/PCT Publication No.:** 2014/123729
 (30) **Priorités/Priorities:** 2013/02/07 (US61/850,097);
 2013/11/04 (US61/962,262)

(51) **Cl.Int./Int.Cl. A61G 13/12** (2006.01),
A61B 6/04 (2006.01), **A61M 5/52** (2006.01)
 (71) **Demandeur/Applicant:**
 G2 MEDICAL, LLC, US
 (72) **Inventeur/Inventor:**
 SAMPOGNARO, GREGORY, US
 (74) **Agent:** BORDEN LADNER GERVAIS LLP

(54) **Titre : PROCÉDES ET APPAREIL D'ACCES RADIAL**
 (54) **Title: RADIAL ACCESS METHODS AND APPARATUS**

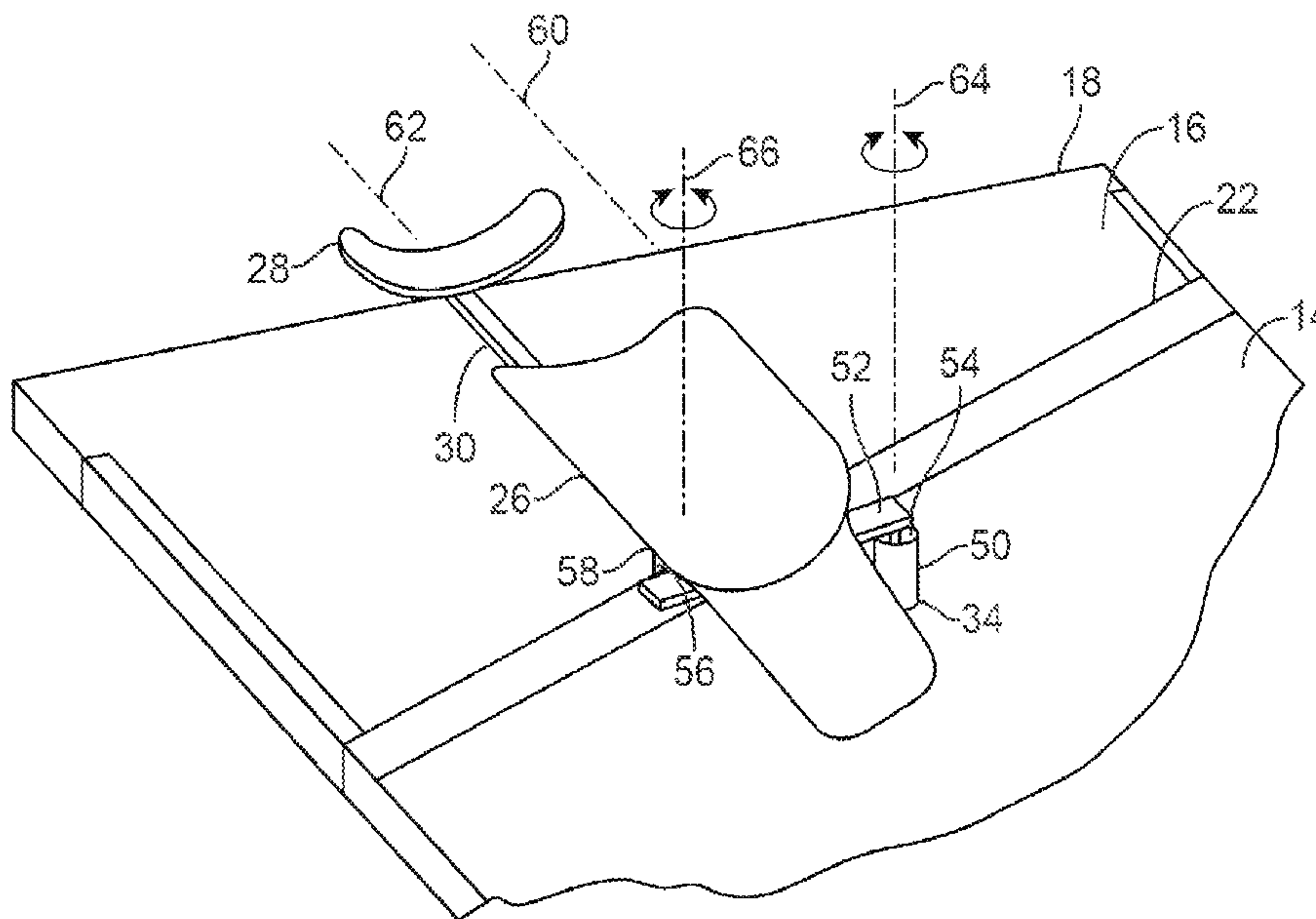

FIG. 2A

(57) **Abrégé/Abstract:**

Radial access methods and apparatus are described for facilitating the securement of the patient's limb for a radial procedure as well as to accommodate for the re-positioning of the patient's body. A radial table assembly may generally comprise a platform defining a surface which is sized to support the limb of the patient, an interface portion attached at a distal end of the platform, wherein the interface portion is radio-lucent and extends at a distance from the platform, and a cradle member rotatably connected to the platform at a location proximal to the interface portion. In other variations, the interface portion is reconfigurable relative to the platform such that an angled edge is reversible relative to the platform.

RADIAL ACCESS METHODS AND APPARATUS

CROSS-REFERENCE TO RELATED APPLICATIONS

[0001] This application claims the benefit of priority to U.S. Prov. Pat. App. Serial Nos. 61/850,097 filed February 7, 2013 and 61/962,262 filed November 4, 2013, each of which is incorporated herein by reference in its entirety.

FIELD OF THE INVENTION

[0002] The present invention relates to methods and apparatus for facilitating radial access procedures. More particularly, the present invention relates to methods and apparatus for facilitating radial access procedures when repositioning the patient is needed or desired.

BACKGROUND OF THE INVENTION

[0003] Cardiac catheterization procedures generally utilize a catheter passed through a major artery, such as a femoral artery, to access a patient's heart. Yet access to the intravascular and cardiac systems may also be achieved through a radial artery and is generally believed to be more convenient and may also reduce both the length of the procedure and the risk of complications during the procedure. However, cardiac catheterization procedures often require the use of numerous surgical instruments including guidewires, intravascular balloons, stents, etc.

[0004] Moreover, imaging systems such as fluoroscopes or other imaging machines are typically utilized during catheterization procedures. Due to the size and weight of these machines, imaging various tissue regions within the patient's body often necessitates re-positioning of the body relative to the imaging system. This requires physically moving the patient's body. However, because of the number of instruments used during a radial access procedure, re-positioning the patient's body is difficult and cumbersome.

[0005] Previous devices have been developed to facilitate radial access. Such devices have included the use of boards or surfaces which extend from the platform upon which the patient is positioned. Such boards are typically clamped or otherwise secured to the platform for supporting the patient's limb, such as their arm, to extend from the body to provide radial

access. However, such boards are cumbersome to use in a surgical setting and fail to provide a stable platform upon which instruments can be placed.

[0006] Other devices have included the use of arm boards or platforms supported by pivoting or jointed arms which can be clamped upon the catheter laboratory table or a separate supporting structure. While such pivoted or jointed arms are able to support a patient's arm for a radial procedure, these devices still fail to provide any stable platform for instruments and further fail to address the need for moving or re-positioning the patient's body relative to an imaging system.

[0007] Accordingly, there exists a need for methods and devices which are able to support any number of instruments for radial access as well as facilitate re-positioning of the patient's body during a radial access procedure.

SUMMARY OF THE INVENTION

[0008] In accessing a radial vessel, e.g., for an interventional procedure, the limb of the patient, such as an arm, is generally positioned to extend the wrist and expose a radial artery. To facilitate the securement of the patient's limb for a radial procedure as well as to accommodate for the re-positioning of the patient's body, a radial table assembly as described may be utilized. The table assembly may generally comprise a platform defining a surface which is sized to support the limb of the patient, an interface portion attached at a distal end of the platform, wherein the interface portion is radio-lucent and extends at a distance from the platform, and a cradle member rotatably connected to the platform at a location proximal to the interface portion. In other variations, the interface portion is reconfigurable relative to the platform such that an angled edge is reversible relative to the platform.

[0009] The cradle assembly itself may be generally comprised of a cradle member which is configured to receive and support the limb of the patient, a connection interface configured to rotatably secure the assembly to a first platform, and a support arm rotatably extending from the connection interface and rotatably coupled to the cradle member, wherein a position and an orientation of the cradle member is dependent upon a position and an orientation of a second platform.

[0010] In use, one method for positioning the patient body with respect to the radial table assembly may generally comprise positioning the limb of the patient body upon the

cradle member which is movably attached to a first platform sized to support the limb, moving a second platform upon which the patient body is placed, where the second platform is in proximity to the first platform, and moving the cradle member relative to the first platform in a manner corresponding to a movement of the second platform such that a position or orientation of the cradle member is dependent upon a position or orientation of the second platform when the limb is positioned upon the cradle member.

[0011] One example of a radial table assembly may generally comprising a back table supported by one or more legs, a radial table portion extending from the back table, and an interface portion further extending from the radial table portion, e.g., in a cantilevered manner. The interface portion may define an angled edge which allows for the table assembly to be positioned relatively at an angle and in close proximity to or adjacent to a catheter laboratory table and provide a platform upon which the patient's limb (such as the arm) may be extended from the patient body positioned upon the table. The table assembly may provide surgeons and practitioners a comfortable way to facilitate procedures, e.g., angiography, percutaneous interventions, etc., through the radial artery.

[0012] The back table may comprise a surgical table or platform and the radial table portion may be attached to a distal edge of the back table along an optionally hinged or pivoting interface and having a width of, e.g., 12-48 inches or more, and a length of, e.g., up to 20 inches or longer. The interface portion may be secured at a distal end of the radial table portion also along an optionally hinged or pivoting interface and may have a similar width as the radial table portion. The interface portion may extend at a distance and terminate at its distal end at the angled edge which may have an angle ranging anywhere from, e.g., 10 degrees and up to 90 degrees (or more particularly 45-55 degrees), relative to the length of the table assembly. While each of the back table and radial table portion may be comprised of various materials which are radio-opaque, e.g., stainless steel, the interface portion may be comprised of a radio-lucent material which is optionally anti-bacterial or able to be disinfected, e.g., various polycarbonate materials such as Lexan® (SABIC Innovative Plastics), ultra-high-molecular-weight polyethylene (UHMW), etc. Having the interface portion comprised of a radio-lucent material may allow for an imaging device such as a fluoroscope (or any other suitable imaging device) to penetrate and image the proximal upper sections of the patient's limb, if needed.

[0013] A cradle assembly may be rotatably secured to the radial table assembly within any one of the connection interfaces which may be aligned along, e.g., the proximal edge of the radial table portion. The cradle assembly may be optionally positioned in any of the connection interfaces depending upon the positioning of the patient body along the catheter laboratory table. The cradle assembly itself may generally comprise a cradle member having a length of, e.g., up to 10 inches or more, and a width of, e.g., 6 inches or more, and which is configured to define a channel to comfortably receive the patient's wrist, forearm, and hand. An optional proximal cradle member may extend adjustably via an extension arm from the cradle member to support the patient's upper arm if needed or desired. The cradle member and optional proximal cradle member may each be fabricated from either a radio-opaque material (such as stainless steel) or from a radio-lucent material (such as polycarbonate) to further allow for imaging of the forearm and hand of the patient if also desired.

[0014] The cradle assembly may define two points of rotation or articulation to enable the rotation of the cradle member relative to a support arm which couples the cradle assembly to the connection interface and to also enable the rotation of the support arm relative to the connection interface and radial table. With the patient body positioned upon the catheter laboratory table, the limb and particularly the hand and wrist may be extended and secured upon a cradle member with the patient's fingers optionally secured to the distal end of the cradle member to extend the wrist. With the limb secured and optionally draped, the radial artery may be readily accessed by any number of percutaneous access or surgical procedures. The surgeon and/or practitioner may be positioned between the catheter laboratory or operating table and the radial table assembly while any number of instruments or interventional tools may be placed or extended upon the radial table portion and/or back table.

[0015] However, if the patient body requires repositioning relative to the imaging device positioned above and below the patient and laboratory table, the laboratory table may be translated either along its length or width while keeping the limb secured to the cradle member. Hence, as the patient body moves relative to the imaging device and relative to the radial table assembly, the patient's limb may also be repositioned in a manner corresponding to the repositioning of the patient body due to the rotation of cradle member (and the hand and wrist positioned upon the cradle member) relative to the support arm and also the rotation of the support arm relative to the radial table portion without interference with the surgeon or

practitioner. These two points of rotation of the cradle member and the support arm relative to the radial table may allow for a full 360 degrees or movement. Alternatively, the rotation of one or both of the cradle member and support arm relative to the radial table portion may be limited to rotate within specified ranges, if so desired. In either case, because the

5 orientation of the patient's limb may be automatically maintained relative to the patient's body despite any translation of the body relative to the imaging device and/or radial table assembly, any instruments or tools extending from the patient's limb and laid upon the back table may be left in place rather than moved to accommodate movement of the patient body.

[0016] Because the radial table assembly may be utilized with a number of different

10 imaging devices, the assembly may be designed to accommodate an imaging system such as a fluoroscope. Such systems typically utilize a C-arm having a detector and x-ray transmitter positioned in apposition to one another at either end of the C-arm. While the imaging system is generally stationary relative to the laboratory table and radial table assembly, the C-arm may be rotatably adjustable for obtaining images of the underlying patient body at various

15 angles. To accommodate such movement of the imaging system, the radial table assembly may be configured to have the radial table portion and interface portion extend at a distance, e.g., anywhere from a foot or up to several feet (or more particularly between 5-6 feet), from the back table in a cantilevered manner to provide for sufficient clearance distance beneath the table in the event that the transmitter (or any other instrument) is positioned beneath the

20 assembly. This cantilevered feature may be incorporated into any of the various embodiments of the table assembly shown or described herein. Measurements and dimensions with respect to the radial table assembly are provided as illustrative examples and may be varied or customized to suit any number of patients as desired.

[0017] Because the interface portion defines an angled edge, the interface portion may

25 be adjustably attached to the radial table portion. Yet another feature may include the radial table portion being retractably folded along its interface relative to the back table. Other variations of the radial table may include embodiments where the radial table may be secured or clamped directly to the catheter laboratory table via one or more securement mechanisms (e.g., clamps, etc.) aligned along the angled edge. While other variations include radial table

30 assemblies which may be secured to a separate back table.

[0018] Additional features and/or accessories may be utilized in combination. For instance, a radiation shield may be attached along the radial table edge. The radiation shield may be attached along any of the edges of the table assembly in proximity to the surgeon or practitioner to provide for additional shielding against, e.g., x-rays, which may be emitted by imaging devices typically used to image the patient's body. Other features may include one or more cushion supports which are configured and shaped for use along the cradle member may be provided with the radial table assembly or separately. Additionally, surgical drapes configured for use with the table assembly or any number of instruments or displays which are positionable upon the back table or radial table may also be provided, if so desired. All or any one of these accessories may be provided in a kit along with the radial table assembly or they may be provided separately.

BRIEF DESCRIPTION OF THE DRAWINGS

[0019] Fig. 1 shows a perspective view of one variation of a radial access table positioned in proximity to a patient platform and having a rotatable support assembly for the patient's arm.

[0020] Figs. 2A and 2B illustrate another variation of a support assembly rotatably mounted upon the radial access table.

[0021] Figs. 3A and 3B show perspective views of a patient's arm extending from a catheter laboratory table while supported upon the support assembly and further illustrating how the patient's arm is movable relative to the stationary radial access table in a manner corresponding to a movement of the catheter laboratory table.

[0022] Fig. 4 shows an illustrative view of how an imaging system such as a fluoroscopy device is positionable relative to the radial access table.

[0023] Fig. 5 shows a perspective view of how an interface portion of the radial access table is reconfigurable relative to the remainder of the table.

[0024] Fig. 6 shows a perspective view of another variation in which an interface portion and radial table is reconfigurable to collapse relative to the back table.

[0025] Fig. 7 shows a perspective view of another variation illustrating the back table supported by a table leg which provides sufficient clearance beneath the table.

[0026] Fig. 8 shows a perspective view of an example of how the interface portion may be secured to the radial table portion.

[0027] Fig. 9 shows a perspective view of an example of how the radial table and interface portion may be reconfigurably secured to the back table.

5 [0028] Fig. 10 shows a perspective view of another example illustrating how the radial table and interface portion may be reconfigurably secured to the back table.

[0029] Fig. 11 shows a perspective view of another variation of a support assembly.

[0030] Figs. 12A and 12B show side and end views of a support arm variation for rotatably securing the support assembly.

10 [0031] Figs. 13A and 13B show perspective and assembly views of another variation of a support assembly.

[0032] Fig. 14 shows a perspective view of the support assembly of Fig. 13A positioned upon a radial access table.

[0033] Figs. 15A and 15B show side and perspective views of yet another variation of
15 the radial access table which may be secured to a catheter laboratory table.

[0034] Fig. 15C shows a perspective view of another variation in which a support leg may be pivotably or retractably connected to the radial table.

[0035] Fig. 15D shows a perspective view illustrating an example of how the table of Fig. 15A may be secured to the catheter laboratory table.

20 [0036] Figs. 16A and 16B show perspective views of yet another variation of the radial access table which may be clamped or secured to a back table.

[0037] Figs. 16C and 16D show perspective views of the table of Fig. 16A secured to a back table and positioned in proximity to a catheter laboratory table.

[0038] Fig. 17 shows a perspective view of a radial access table incorporating an
25 optional drape or shield.

[0039] Fig. 18 shows an assembly view of a radial access table and optional accessories which may be specially configured for use with the table.

DETAILED DESCRIPTION OF THE INVENTION

30 [0040] In accessing a radial vessel, e.g., for an interventional procedure, the limb of the patient is typically extended away from the body and secured to provide a stable insertion

pathway for any number of instruments such as catheters, guidewires, intravascular balloons, stent scaffolds, etc. The limb of the patient, such as an arm, is generally positioned to extend the wrist and expose a radial artery.

[0041] One example of a radial table assembly **10** is illustrated in the perspective view of Fig. 1 which shows the table assembly **10** generally comprising a back table **12** supported by one or more legs, a radial table portion **14** extending from the back table **12**, and an interface portion **16** further extending from the radial table portion **14**, e.g., in a cantilevered manner. The interface portion **16** may define an angled edge **18** which allows for the table assembly **10** to be positioned relatively at an angle and in close proximity to or adjacent to a catheter laboratory table **40** and provide a platform upon which the patient's limb **LM** (such as the arm) may be extended from the patient body **PT** positioned upon the table **40**. The table assembly **10** may provide surgeons and practitioners a comfortable way to facilitate procedures, e.g., angiography, percutaneous interventions, etc., through the radial artery.

[0042] The back table **12** may comprise a surgical table or platform and the radial table portion **14** may be attached to a distal edge of the back table **12** along an optionally hinged or pivoting interface **20** and having a width of, e.g., 12-48 inches or more, and a length of, e.g., up to 20 inches or longer. The interface portion **16** may be secured at a distal end of the radial table portion **14** also along an optionally hinged or pivoting interface **22** and may have a similar width as the radial table portion **14**. The interface portion **16** may extend at a distance and terminate at its distal end at the angled edge **18** which may have an angle ranging anywhere from, e.g., 10 degrees and up to 90 degrees (or more particularly 45-55 degrees), relative to the length of the table assembly **10**. While each of the back table **12** and radial table portion **14** may be comprised of various materials which are radio-opaque, e.g., stainless steel, the interface portion **16** may be comprised of a radio-lucent material which is optionally anti-bacterial or able to be disinfected, e.g., various polycarbonate materials such as Lexan® (SABIC Innovative Plastics), ultra-high-molecular-weight polyethylene (UHMW), etc. Having the interface portion **16** comprised of a radio-lucent material may allow for an imaging device such as a fluoroscope (or any other suitable imaging device) to penetrate and image the proximal upper sections of the patient's limb **LM**, if needed.

[0043] A cradle assembly **24** may be rotatably secured to the radial table assembly **10** within any one of the connection interfaces **34**, **36**, **38** which may be aligned along, e.g., the

proximal edge of the radial table portion **14** as shown. The cradle assembly **24** may be optionally positioned in any of the connection interfaces **34**, **36**, **38** depending upon the positioning of the patient body **PT** along the catheter laboratory table **40**. The cradle assembly **24** itself may generally comprise a cradle member **26** having a length of, e.g., up to 5 10 inches or more, and a width of, e.g., 6 inches or more, and which is configured to define a channel to comfortably receive the patient's wrist, forearm, and hand **HN**. An optional proximal cradle member **28** may extend adjustably via an extension arm **30** from the cradle member **26** to support the patient's upper arm if needed or desired. The cradle member **26** and optional proximal cradle member **28** may each be fabricated from either a radio-opaque 10 material (such as stainless steel) or from a radio-lucent material (such as polycarbonate) to further allow for imaging of the forearm and hand of the patient if also desired.

[0044] The cradle assembly **24** may define two points of rotation or articulation to enable the rotation of the cradle member **26** relative to a support arm **32** which couples the cradle assembly **24** to the connection interface **34** and to also enable the rotation of the 15 support arm **32** relative to the connection interface **34** and radial table **14**. With the patient body **PT** positioned upon the catheter laboratory table **40**, the limb **LM** and particularly the hand and wrist may be extended and secured upon a cradle member **26** with the patient's fingers optionally secured to the distal end of the cradle member **26** to extend the wrist. With the limb **LM** secured and optionally draped, the radial artery may be readily accessed by any 20 number of percutaneous access or surgical procedures. The surgeon and/or practitioner may be positioned between the catheter laboratory table **40** (or operating table) and the radial table assembly **10** while any number of instruments or interventional tools may be placed or extended upon the radial table portion **14** and/or back table **12**.

[0045] However, if the patient **PT** body requires repositioning relative to the imaging 25 device positioned above and below the patient **PT** and laboratory table **40**, the laboratory table **40** may be translated either along its length or width while keeping the limb **LM** secured to the cradle member **26**. Hence, as the patient body **PT** moves relative to the imaging device and relative to the radial table assembly **10**, the patient's limb **LM** may also be repositioned in a manner corresponding to the repositioning of the patient body **PT** due to the rotation of 30 cradle member **26** (and the hand and wrist positioned upon the cradle member **26**) relative to the support arm **32** and also the rotation of the support arm **32** relative to the radial table

portion **14** without interference with the surgeon or practitioner. These two points of rotation of the cradle member **26** and the support arm **32** relative to the radial table may allow for a full 360 degrees or movement. Alternatively, the rotation of one or both of the cradle member **26** and support arm **32** relative to the radial table portion **14** may be limited to rotate within specified ranges, if so desired. In either case, because the orientation of the patient's limb **LM** may be automatically maintained relative to the patient's body **PT** despite any translation of the body **PT** relative to the imaging device and/or radial table assembly **10**, any instruments or tools extending from the patient's limb **LM** and laid upon the back table **12** may be left in place rather than moved to accommodate movement of the patient body **PT**.

10 [0046] Figs. 2A and 2B show perspective detail views (without patient limb **LM** shown for clarity) of another variation of the cradle assembly to illustrate its relative movement. In this variation, the cradle member **26** may be coupled to the radial table portion **14** via a support arm **52** (described in further detail below) having an insertion rod extending perpendicularly relative to the support arm **52**. A receiving support **50** which defines a receiver opening **54** for receiving the insertion rod of the support arm **52** may be secured within the connection interface **34**. Although a single connection interface **34** is shown in this example, any number of additional connection interfaces may be optionally placed at different locations along the radial table portion **14** to accommodate various orientations. A second receiver support **56** may extend from the cradle member **26** and define a second receiver opening **58** for receiving a second perpendicular insertion rod extending from the support arm **52**.

20 [0047] The radial table assembly centerline **60** is shown and the cradle assembly centerline **62** is also shown for illustrative purposes. Fig. 2A shows how the cradle assembly centerline **62** is initially oriented relative to the radial table assembly centerline **60**. As the laboratory table **40** and the patient body **PT** is repositioned relative to a stationary imaging device and stationary radial table assembly **10**, the patient's arm may correspondingly cause the cradle member **26** to rotate about its cradle axis of rotation **64** as well as the cradle member axis of rotation **66**. Even in its reoriented position shown in Fig. 2B, the orientation of the cradle assembly centerline **62** is still maintained relative to the radial table assembly centerline **60**.

30

[0048] Another example is shown in the perspective views of Figs. 3A and 3B which illustrate the radial access table assembly **10** placed against or in proximity to the laboratory table **40**. An example of the patient's limb **LM** extending from the laboratory table **40** may be seen initially secured upon the cradle member **26**. As the laboratory table **40** is translated, 5 e.g., in a direction of motion **68** and **68'**, the cradle member **26** may correspondingly rotate about its cradle axis of rotation **64** and its cradle member axis of rotation **66** such that the cradle member **26** is repositioned relative to the radial table portion **14** but an orientation of the limb **LM** is maintained relative to the patient body **PT** by the maintained orientation of the cradle member **26**.

10 [0049] Because the radial table assembly **10** may be utilized with a number of different imaging devices, the assembly **10** may be designed to accommodate an imaging system **70** such as a fluoroscope, as shown in the perspective view of Fig. 4. Such systems **70** typically utilize a C-arm **72** having a detector **74** and x-ray transmitter **76** positioned in apposition to one another at either end of the C-arm **72**. While the imaging system **70** is 15 generally stationary relative to the laboratory table **40** and radial table assembly **10**, the C-arm **72** may be rotatably adjustable for obtaining images of the underlying patient body at various angles. To accommodate such movement of the imaging system **70**, the radial table assembly **10** may be configured to have the radial table portion **14** and interface portion **16** extend at a distance, e.g., anywhere from a foot or up to several feet (or more particularly between 5-6 20 feet), from the back table **12** in a cantilevered manner to provide for sufficient clearance distance **78** beneath the table in the event that the transmitter **76** (or any other instrument) is positioned beneath the assembly **10**. This cantilevered feature may be incorporated into any of the various embodiments of the table assembly shown or described herein. Measurements and dimensions with respect to the radial table assembly are provided as illustrative examples 25 and may be varied or customized to suit any number of patients as desired.

[0050] Another feature of the table assembly **10** is shown in the perspective view of Fig. 5 which illustrates a reconfigurable interface portion **16**. Because the interface portion defines an angled edge **18**, the interface portion **16** may be adjustably attached to the radial table portion **14**. While the interface portion **16** may be entirely removable from the radial 30 table portion **14**, the variation shown illustrates an interface portion **16** which may be rotatably coupled to the radial table portion **14**. The interface portion **16** may be coupled to

the radial table portion via a point of rotation **80** which allows the angled edge **18** to be reconfigured into an opposite direction to enable the placement of the radial table assembly **10** on the opposite side of the laboratory table **40**, e.g., from a left side to a right side of the laboratory table **40**, to facilitate access through either arm of the patient. One or more mating features **82**, **84** may project along the interface **22** to secure the interface **22** and prevent free rotation of the interface portion **16** relative to the radial table portion **14** during use.

[0051] Yet another feature is shown in the perspective view of Fig. 6 which shows how the radial table portion **14** may be retractably folded along its interface **20** relative to the back table **12**. By unlocking the radial table portion **14** from the back table **12**, both the table portion **14** and interface portion **16** may be folded via one or more pivots or hinges along interface **20** for storage or in the event that only the back table **12** is to be utilized for a procedure. One or more radial table mating feature **86**, **88** may project along the interface **20** to secure the interface **20** between the radial table portion **14** and the back table **12** when in use.

[0052] It is intended that both the rotatable interface portion **16** shown in Fig. 5 as well as the pivoting radial table portion **14** may be incorporated together or individually with any of the embodiments described herein and in any combination as practicable. For instance, each of the features shown and described in Figs. 3A-3B as well as Figs. 4-6 may be combined into a single embodiment of a radial table assembly, if so desired.

[0053] Fig. 7 shows a perspective view of yet another variation of the radial table assembly. In this example, the back table **12** may utilize a single table support **90** which projects perpendicularly from a distal end of the back table **12**. Positioning of the table support **90** at the distal end may provide for sufficient clearance space **92** beneath the radial table portion **14** and interface portion **16** as well as beneath the back table **12** as well.

[0054] Fig. 8 shows a perspective view of one variation for implementing the pivoting point of rotation shown above in Fig. 5 between the interface portion **16** and radial table portion **14**. A support member **100** may extend rigidly from the interface portion **16** for rotatable insertion within a receiving collar **102** defined along the radial table portion. A distal portion of the support member **100** may extend beyond the collar **102** to provide for a biasing member **104**, e.g., a spring, to be secured therebetween. The biasing member **104** may provide for a biasing force to keep the interface portion **16** against the radial table portion

14 while still allowing for the rotation of support member **100** and interface portion **16** about collar **102**.

[0055] Aside from the rotation of the interface portion **16**, Fig. 9 shows a perspective view of one variation for implementing the pivoting interface between the radial table portion **14** and the back table **12** shown above in Fig. 6. In this variation, locking brackets **106** may be secured between the radial table portion **14** and back table **12**. Such brackets **106** may be hinged to selectively provide for repositioning of the radial table portion **14** in its cantilevered position as well as its retracted position. Fig. 10 shows another variation for implementing a pivoting interface between the radial table portion **14** and the back table **12**. In this variation, one or more sliding bolts **108**, **108'** may retractably extend from or to the back table **12** for securement within a corresponding receiving channel **110**, **110'** defined along either the radial table portion **14** or back table **12**. When the one or more sliding bolts **108**, **108'** are retracted, the radial table portion **14** may be lowered but when the one or more sliding bolts **108**, **108'** are extended, the radial table portion **14** may be locked into its cantilevered configuration.

[0056] Turning now to the cradle assembly, Fig. 11 shows a perspective view of another variation of the cradle assembly having one or more optional locking controls **120**, **122**. Such a locking control **122** may provide for either free or tensioned rotation of the cradle member **26** or full locking of the cradle member **26** if needed. The locking control **120** may also provide for selective locking of the extension arm **30** when adjusting a position of the proximal cradle member **28**. Also shown in this variation is a curved support arm **124** which may rotatably extend between cradle member **26** and the connection interface defined within the radial table portion. The support arm **124** may be an arcuate arm which can be curved and lengthened to vary the height of the cradle member **26** from the underlying radial table portion **14**.

[0057] In yet another variation of the support arm, Figs. 12A and 12B show side and end views of a support arm **52** having a rectangular cross-sectional area and a length of, e.g., about 6-7 inches. An insertion rod **130** may extend perpendicularly from the support arm **52** and may be rotatably inserted within the receiver support **56** of the cradle assembly **24**. Likewise, an insertion rod **132** may extend perpendicularly from the support arm **52** in a direction opposite to insertion rod **130** and may be rotatably inserted within connection interface **34** or any one of the other connection interfaces defined within the radial table **14**.

An interface collar **134** may also be defined around the insertion rod **132** adjacent to the support arm for contacting against the receiving support **50**. One or more contact projections **136** may also project from the interface collar **134** to facilitate rotation of the support arm **52** relative to the connection interface **34** particularly when the weight of the patient's limb **LM** is bearing down upon the support arm **52**.

[0058] Figs. 13A and 13B show perspective and assembly views of yet another variation of the cradle assembly. In this variation, the cradle member **26** and support arm **52** may be rotatably coupled to a base **140** which is separate from the radial table portion **14**. The base **140** shown may have one or more gussets **144** to provide for structural integrity and may further define an insertion rod channel **142** and an optional securement mechanism **146** extending from the insertion rod channel **142**. With this variation, the cradle member **26** and base **140** may be positioned upon the radial table or upon another platform. Fig. 14 shows a perspective view of a radial table assembly having the cradle member **26** and base **140** positioned upon the back table **12** supported by a table support **152**. The interface portion **150** is radio-lucent and sized to be thicker than the back table **12** in this variation although the thickness of the interface portion **150** may be suitably reduced.

[0059] Turning now to the table assembly, Figs. 15A and 15B show side and perspective views of yet another variation of a radial table assembly **160** generally comprised of a radial table portion **162** and interface portion **164** similar to the other variations. Yet this variation may be configured to be secured or clamped directly to the catheter laboratory table **40** via one or more securement mechanisms **166** (e.g., clamps, etc.) aligned along the angled edge. The distal end of the radial table portion **162** may be supported via a support **168** which may be coupled to the table via an optional retraction or pivoting mechanism **170** which may allow for the support **168** to be pivoted against the table portion **162** and secured by a securement mechanism **172** such as a clamp, as shown in the perspective view of Fig. 15C. Fig. 15D shows a perspective view illustrating how the interface portion **164** may be attached by the securement mechanisms **166** along a side of the laboratory table **40** to extend at an angle. The patient **PT** may extend their arm along the interface portion **164** to provide for radial access as needed. Also, as the laboratory table **40** moves to reposition the patient relative to an imaging device, the radial table assembly **160** may move with the table **40**.

With this variation, the cradle assembly may still positioned upon the radial table portion **162** for use as previously described.

[0060] Figs. 16A and 16B show perspective views of another table assembly variation which may be secured to a separate back table. The radial table assembly **180** shown may generally comprise a radial table **182** having the interface portion **150** and securement mechanisms **192**, **194** for securement to the back table as well as support arms **184**, **186** which may extend, e.g., at an angle from the radial table **182** for further securement to the legs or supports of the back table via corresponding clamping mechanisms **188**, **190**. Fig. 16C illustrates how the radial table **182** may be clamped to a separate back table **198** via the securement mechanisms **192**, **194**. The support arms **184**, **186** may also be seen extending from the radial table **182** for attachment to the table legs **196** of the back table **198**. In use, as shown in the perspective view of Fig. 16D, the radial table assembly **180** attached to the back table **198** may be placed against the laboratory table **40** with the angled interface portion **150** positioned against the table **40**. The cradle assembly may be positioned upon the radial table **182** or other rotatably secured to the radial table **182** for use in the manner described herein with the patient **PT**.

[0061] Aside from the table assembly, additional features and/or accessories may be utilized in combination. One example is shown in the perspective view of Fig. 17 which shows a radiation shield **200** which may be comprised of a single curtain or sheet or a number of individual shielded strips **202** which may be attached along the radial table edge **204**. The radiation shield **200** may be attached along any of the edges of the table assembly in proximity to the surgeon or practitioner to provide for additional shielding against, e.g., x-rays, which may be emitted by imaging devices typically used to image the patient's body.

[0062] Fig. 18 shows an assembly view of additional features and/or accessories which may also be used in combination with the radial table assembly. For instance, one or more cushion supports **210** which are configured and shaped for use along the cradle member **26** may be provided with the radial table assembly or separately. Additionally, surgical drapes **212** configured for use with the table assembly or any number of instruments or displays **214** which are positionable upon the back table **12** or radial table **14** may also be provided, if so desired. All or any one of these accessories may be provided in a kit along with the radial table assembly or they may be provided separately.

[0063] Moreover, it is further intended that any of the individual features described herein may be utilized in any number of combinations with any other feature as practicable.

[0064] The applications of the devices and methods discussed above are not limited to the support of arms but may include any number of further applications. Moreover, such
5 devices and methods may be applied to other portions of the body. Modification of the above-described assemblies and methods for carrying out the invention, combinations between different variations as practicable, and variations of aspects of the invention that are obvious to those of skill in the art are intended to be within the scope of the claims.

CLAIMS

What is claimed is:

1. A table assembly, comprising:

a platform defining a surface which is sized to support a limb of a patient;

5 an interface portion attached at a distal end of the platform, wherein the interface portion is radio-lucent and extends at a distance from the platform; and

a cradle member rotatably connected to the platform at a location proximal to the interface portion.

10 2. The assembly of claim 1 wherein the interface portion is rotatably adjustable relative to the platform.

3. The assembly of claim 1 wherein the interface portion defines an edge which is angled relative to the platform such that the angled edge is positionable against an additional
15 platform.

4. The assembly of claim 1 wherein the interface portion extends at the distance which is sized to accommodate an imaging apparatus without interference beneath the interface portion.

20

5. The assembly of claim 1 wherein the cradle member is configured to receive and support a limb of a patient.

6. The assembly of claim 5 further comprising:

25 a connection interface configured to secure the cradle member to the platform; and

a support arm rotatably extending from the connection interface to the cradle member.

7. The assembly of claim 1 further comprising a radio-opaque barrier extending from the interface portion and/or platform.

30

8. A table assembly, comprising:

a platform defining a surface which is sized to support a limb of a patient;
an interface portion attached at a distal end of the platform,
wherein the interface portion is radio-lucent and extends at a distance from the
platform, and,

5 wherein the interface portion is reconfigurable relative to the platform such that the
angled edge is reversible relative to the platform.

9. The assembly of claim 8 the interface portion defines an edge which is angled
relative to the platform such that the angled edge is positionable against an additional
10 platform.

10. The assembly of claim 8 wherein the interface portion extends at the distance
which is sized to accommodate an imaging apparatus without interference beneath the
interface portion.

15

11. The assembly of claim 8 further comprising a cradle member configured to
receive and support a limb of a patient and rotatably connected to the platform at a location
proximal to the interface portion.

20

12. The assembly of claim 11 further comprising:
a connection interface configured to secure the cradle member to the platform; and
a support arm rotatably extending from the connection interface to the cradle member.

13. The assembly of claim 8 further comprising a radio-opaque barrier extending
25 from the interface portion and/or platform.

14. A support assembly, comprising:
a cradle member which is configured to receive and support a limb of a patient;
a connection interface configured to rotatably secure the assembly to a first platform;
30 and,

a support arm rotatably extending from the connection interface and rotatably coupled to the cradle member,

wherein a position and an orientation of the cradle member is dependent upon a position and an orientation of a second platform.

5

15. The assembly of claim 14 wherein the position and the orientation of the cradle member is dependent upon the position and the orientation of a second platform via the limb extending between the first platform and the second platform.

10

16. The assembly of claim 14 further comprising:

a first pivot rotatably coupled between the connection interface and a proximal end of the support arm; and

a second pivot rotatably coupled between the cradle member and a distal end of the support arm.

15

17. The assembly of claim 14 further comprising an interface portion attached at a distal end of the platform, wherein the interface portion is radio-lucent and extends at a distance from the platform.

20

18. The assembly of claim 17 wherein the interface portion is rotatably adjustable relative to the platform.

19. The assembly of claim 17 wherein the interface portion defines an edge which is angled relative to the platform such that the angled edge is positionable against the second platform.

25

20. The assembly of claim 17 wherein the interface portion extends at the distance which is sized to accommodate an imaging apparatus without interference beneath the interface portion.

30

21. The assembly of claim 17 further comprising a radio-opaque barrier extending from the interface portion and/or platform.

22. A method of positioning a patient body, comprising:

5 positioning a limb of the patient body upon a cradle member which is movably attached to a first platform sized to support the limb;

moving a second platform upon which the patient body is placed, where the second platform is in proximity to the first platform; and

10 moving the cradle member relative to the first platform in a manner corresponding to a movement of the second platform such that a position or orientation of the cradle member is dependent upon a position or orientation of the second platform when the limb is positioned upon the cradle member.

23. The method of claim 22 further comprising imaging the body via an imager while
15 moving the second platform.

24. The method of claim 22 further comprising positioning a radio-lucent interface portion beneath a portion of the limb prior to moving the cradle member, where the interface portion is attached at a distal end of the first platform.

20

25. The method of claim 22 wherein moving the cradle member further comprises maintaining a stationary position of the first platform.

26. The method of claim 22 wherein moving a second platform comprises rotating the
25 cradle member relative to the first platform via a connection interface rotatably attached at a distal end of the first platform.

27. The method of claim 26 further comprising rotating the cradle member relative to
the first platform via a support arm rotatably extending from the connection interface to the
30 cradle member.

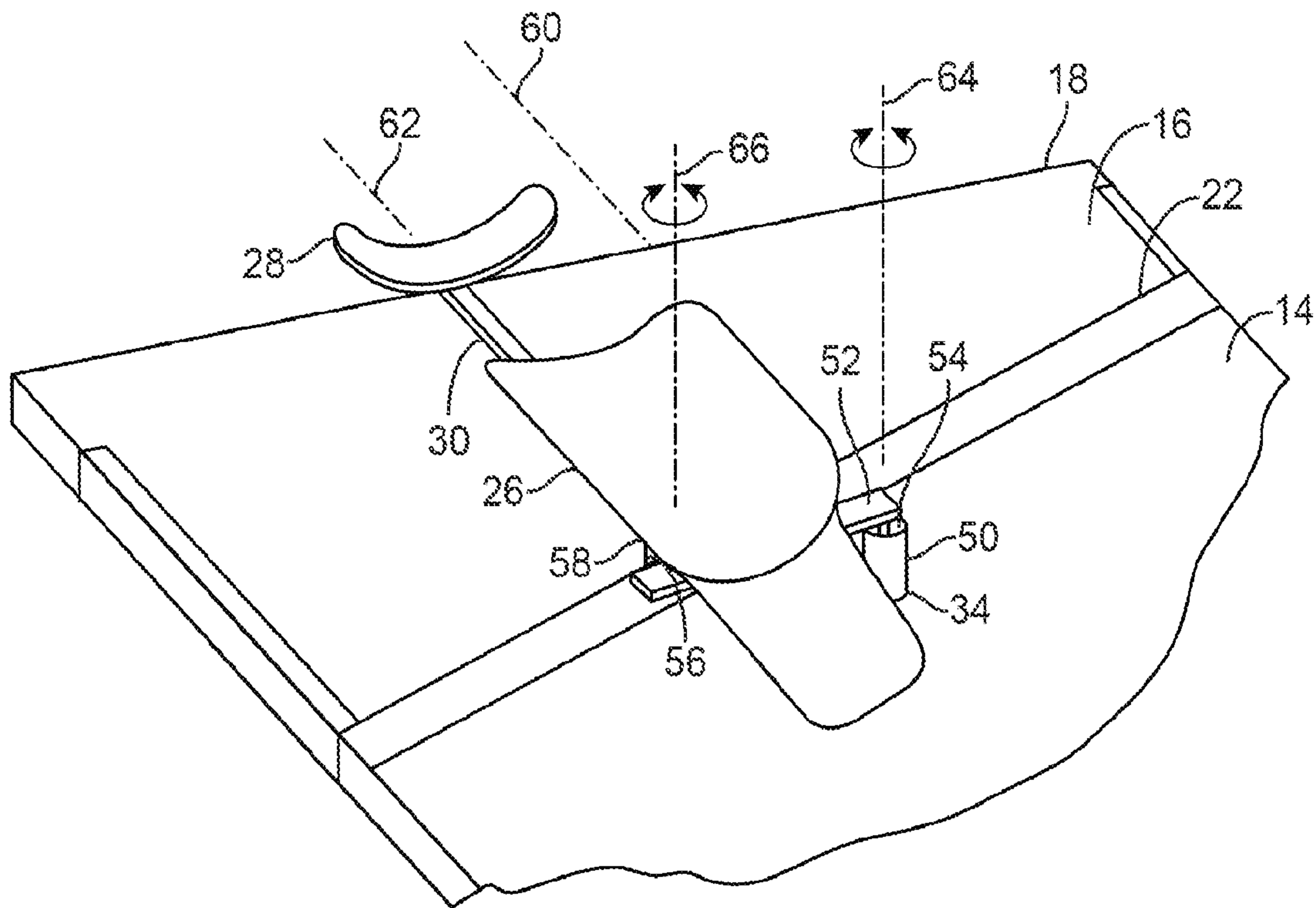

FIG. 2A

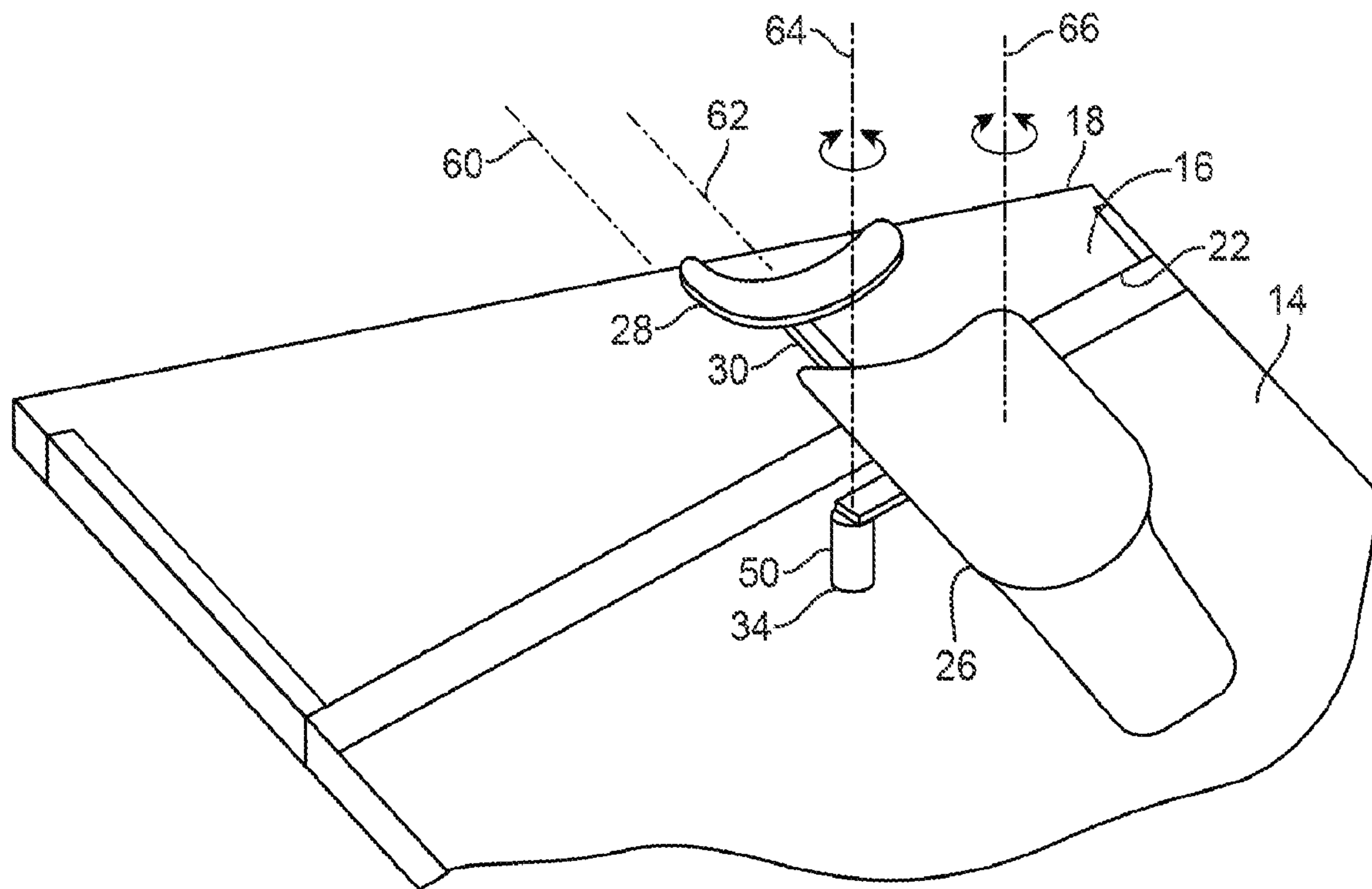

FIG. 2B

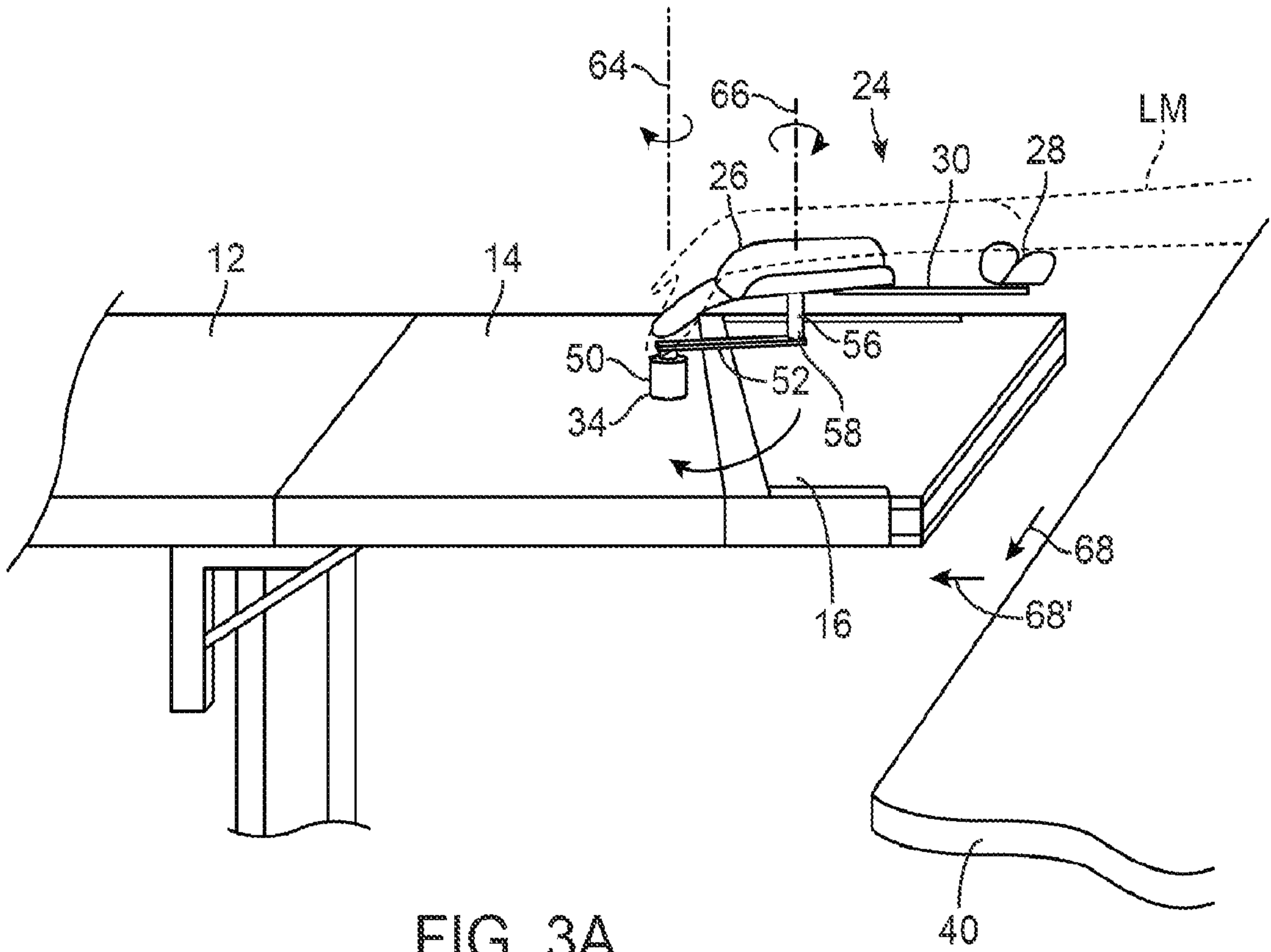

FIG. 3A

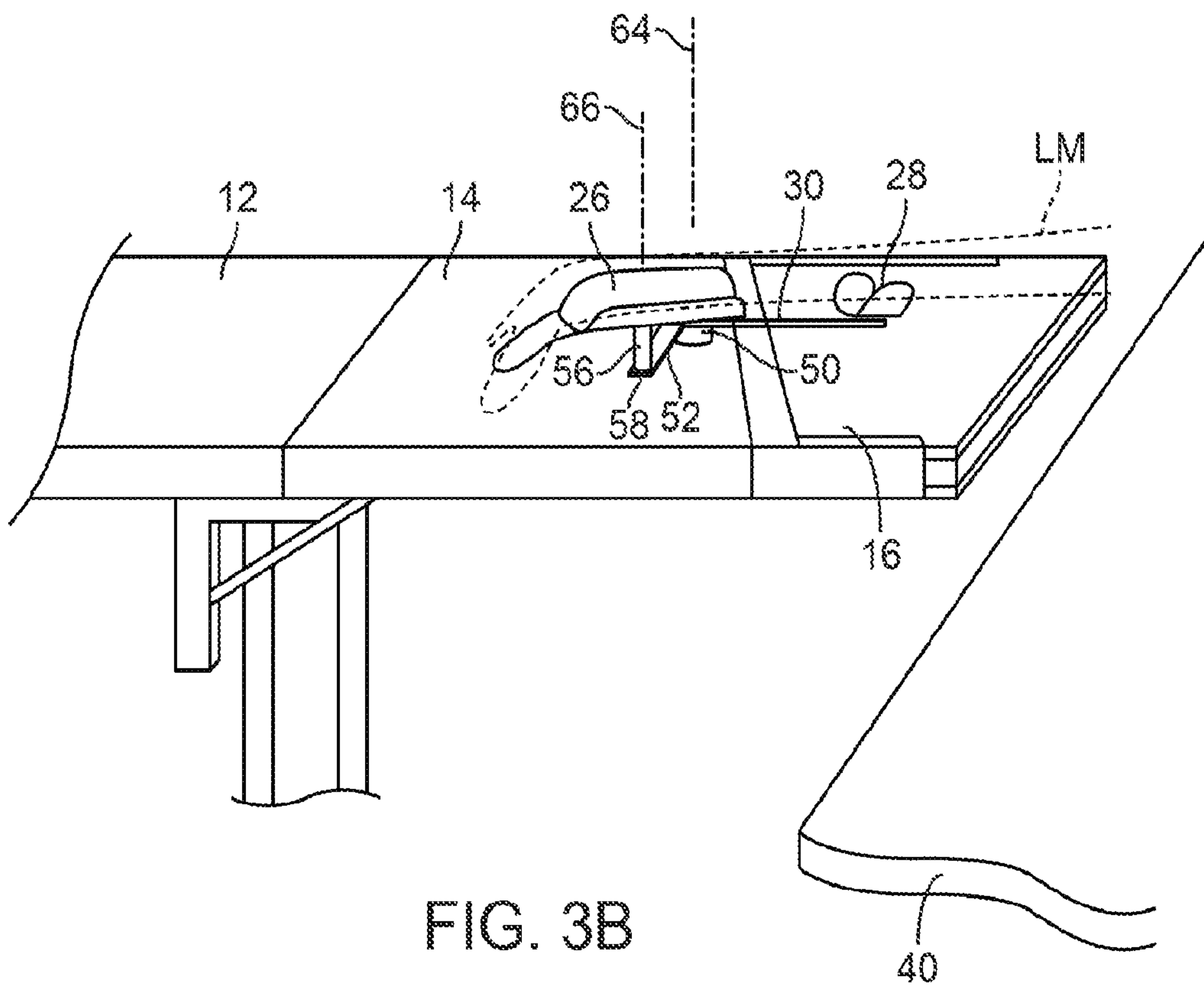

FIG. 3B

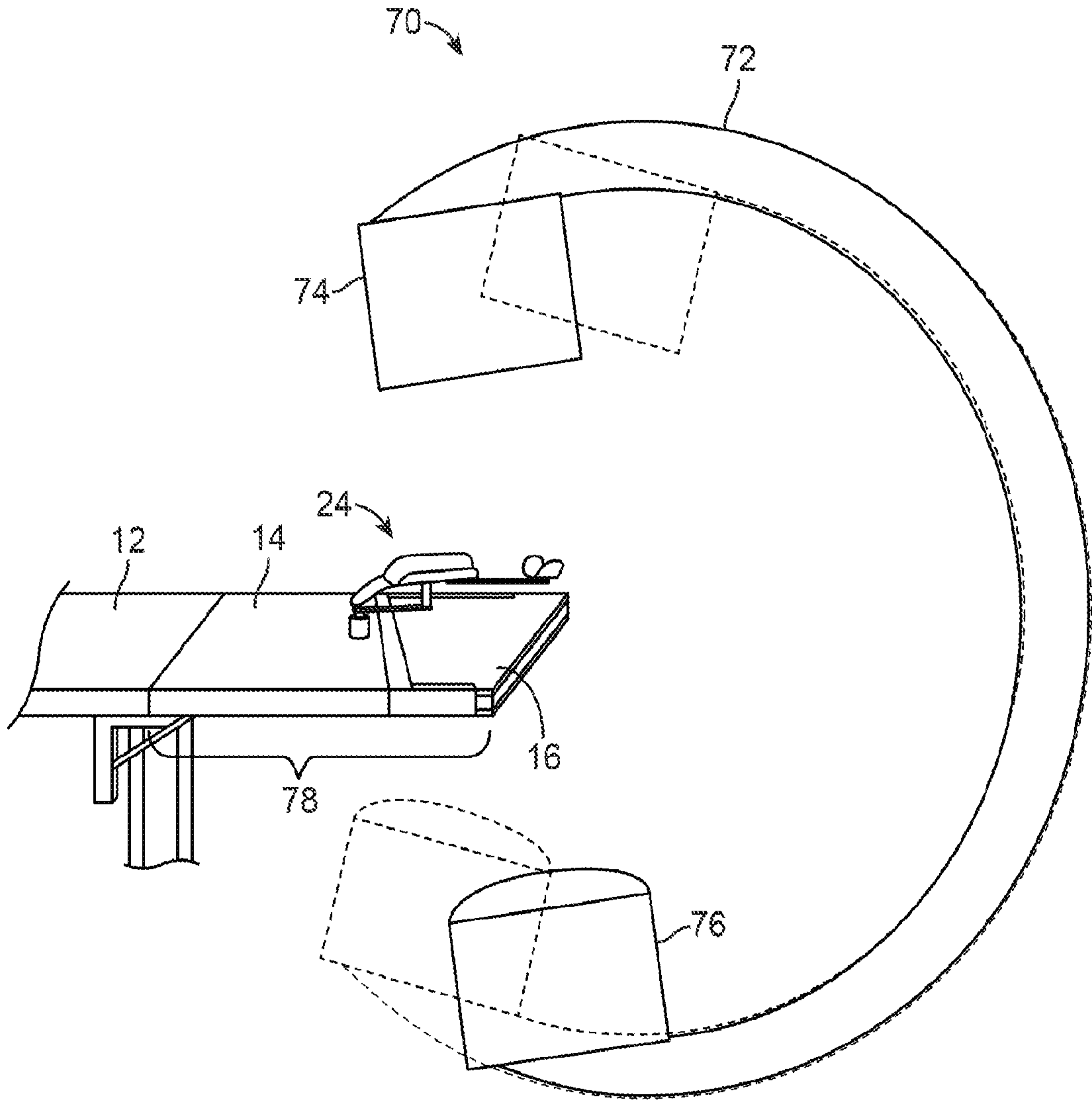

FIG. 4

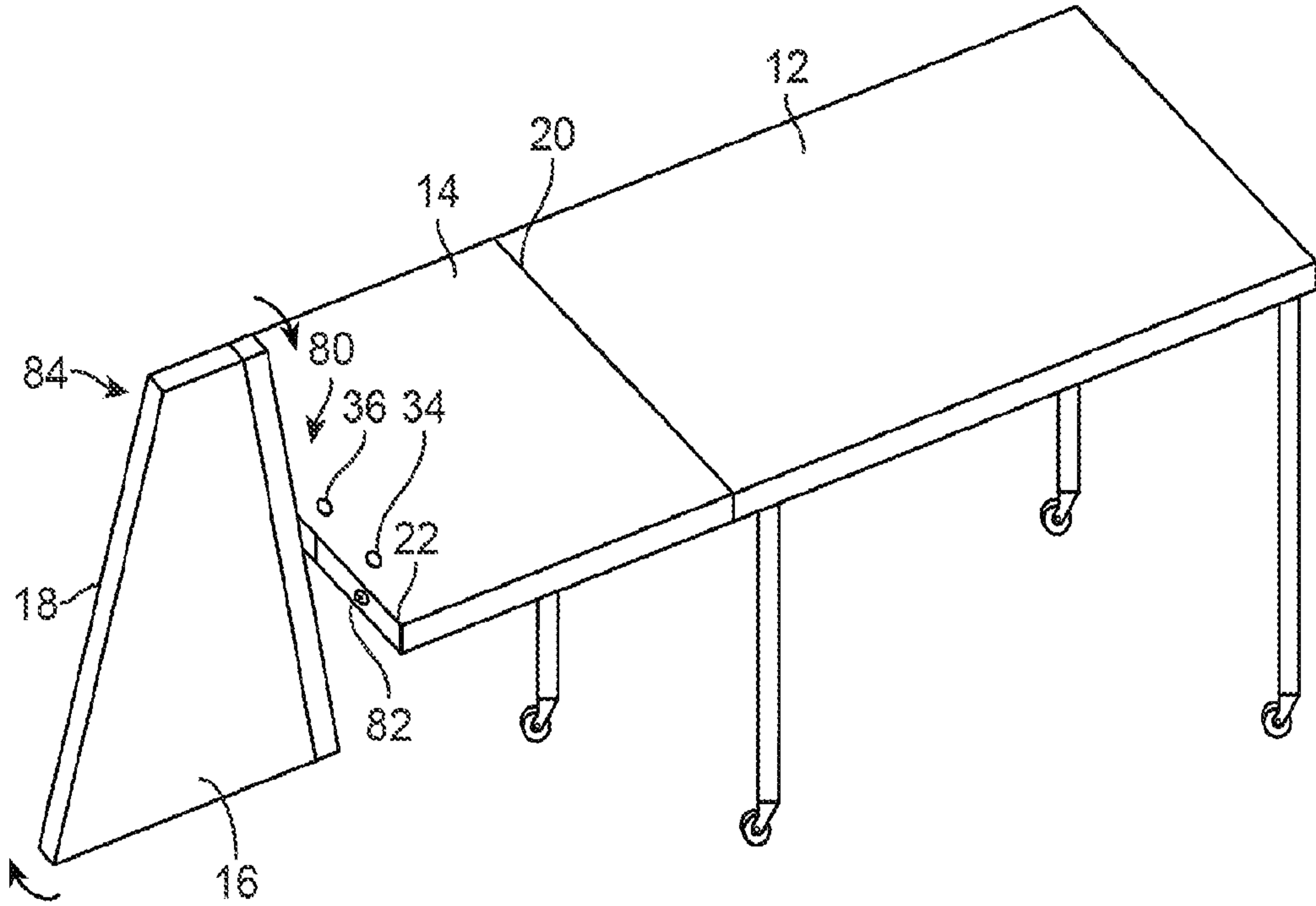

FIG. 5

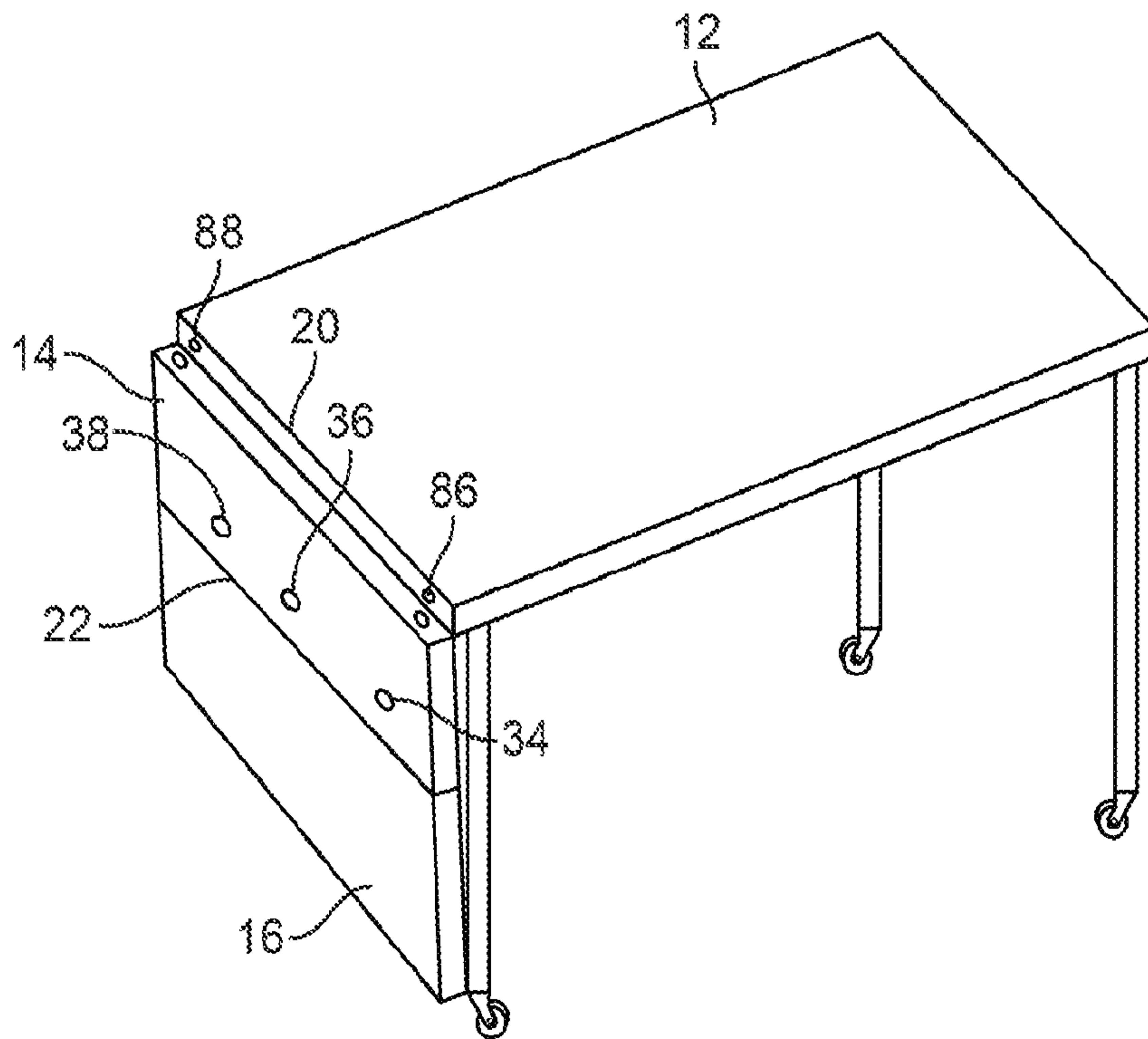

FIG. 6

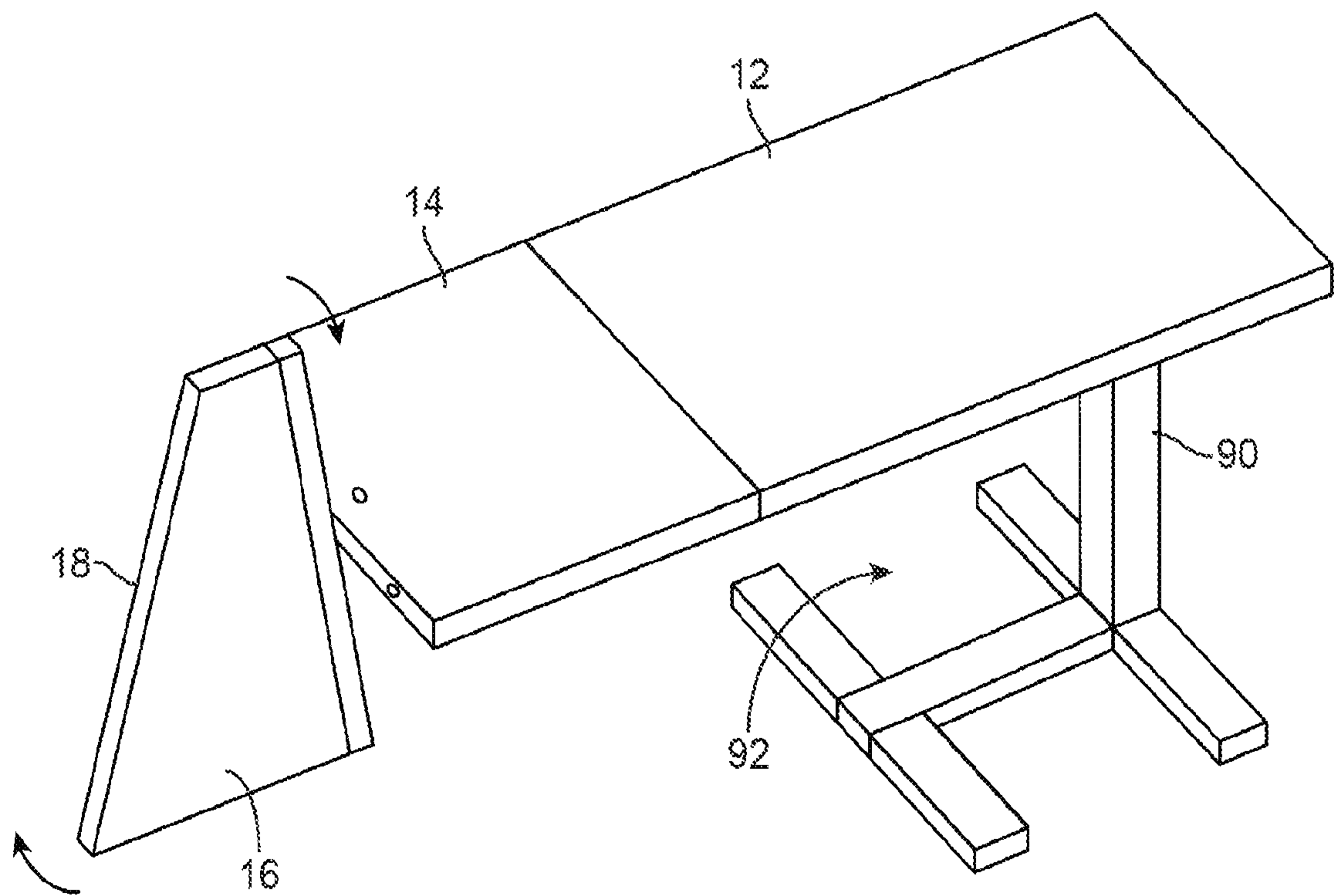

FIG. 7

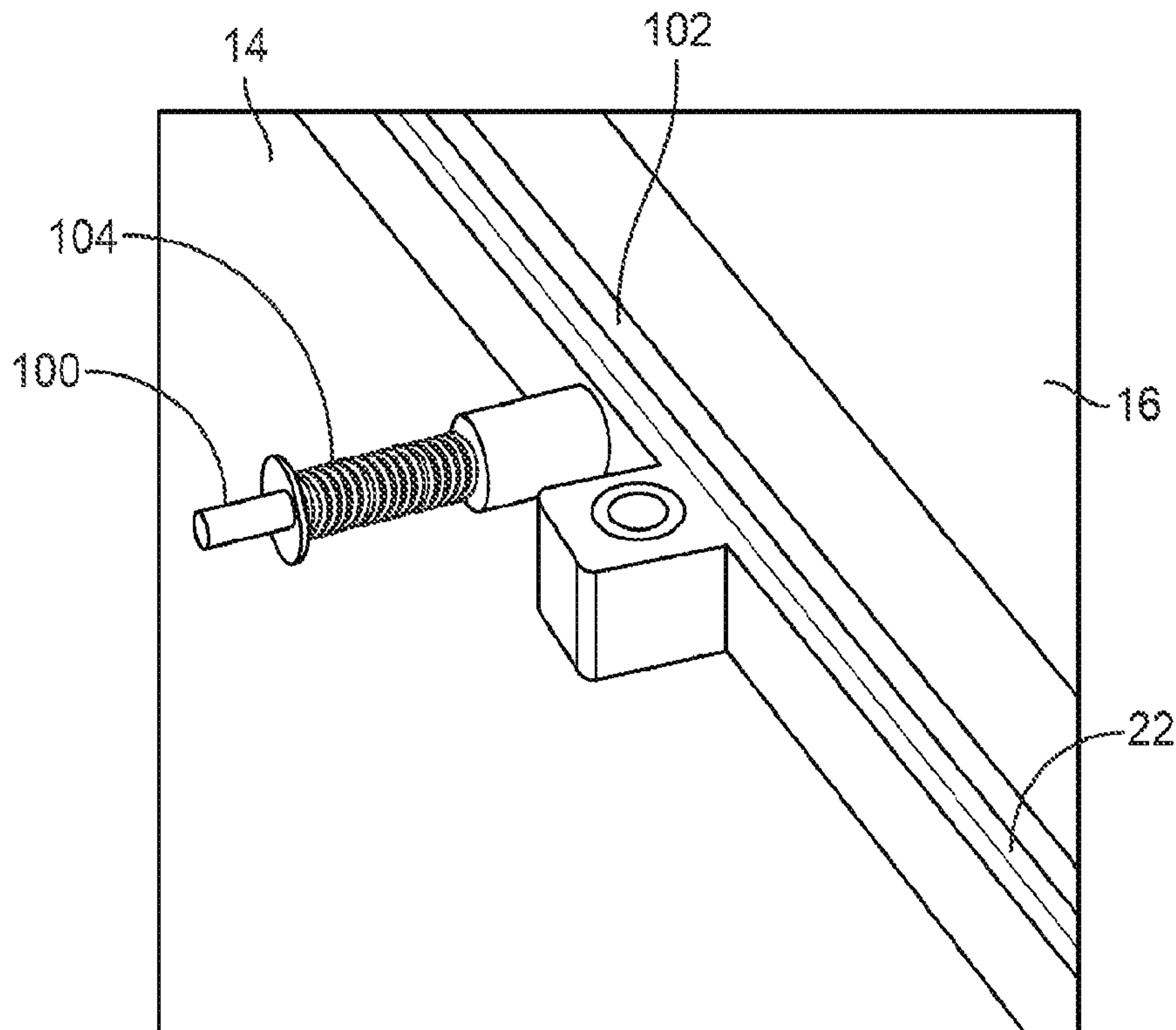

FIG. 8

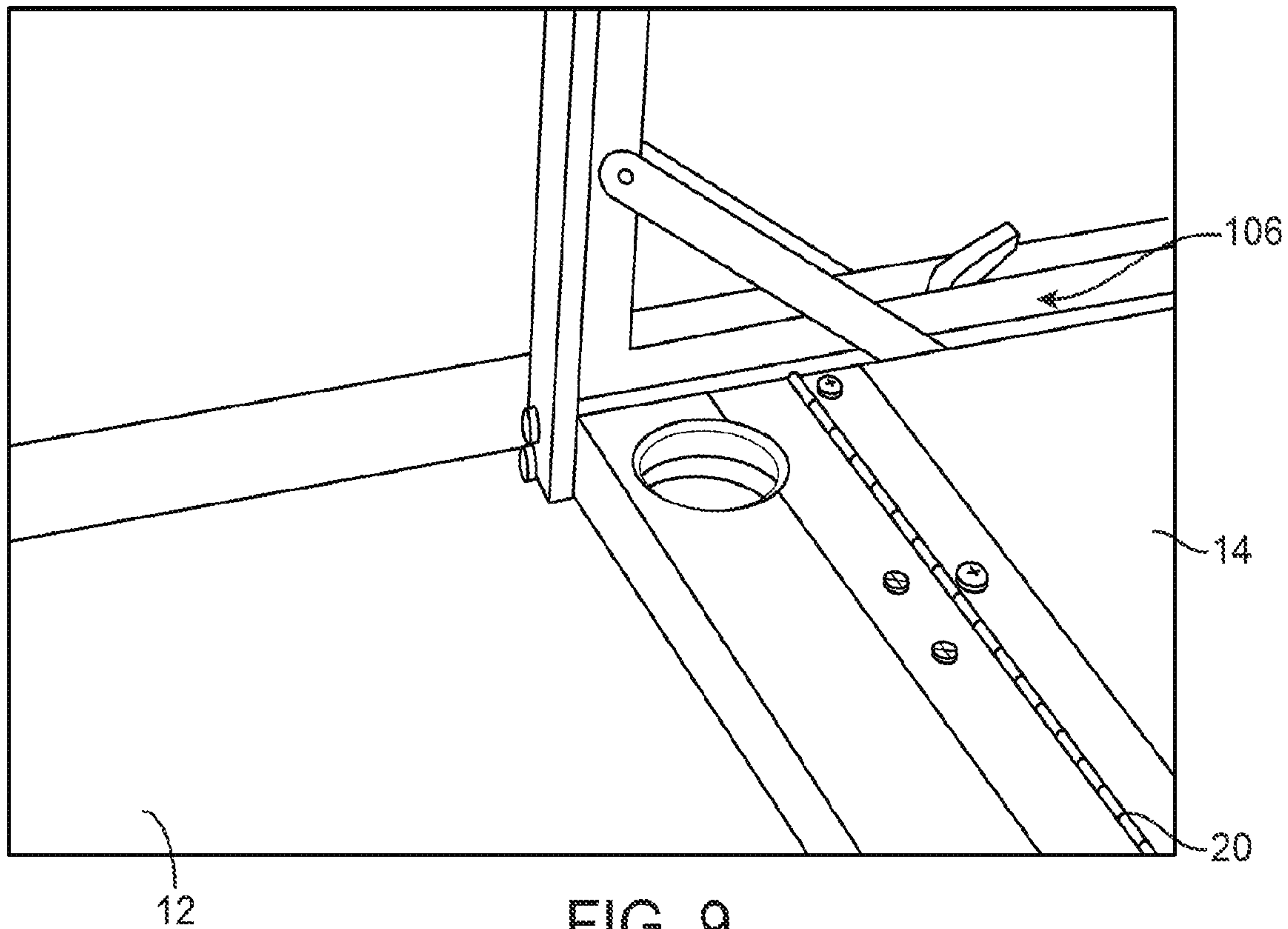

FIG. 9

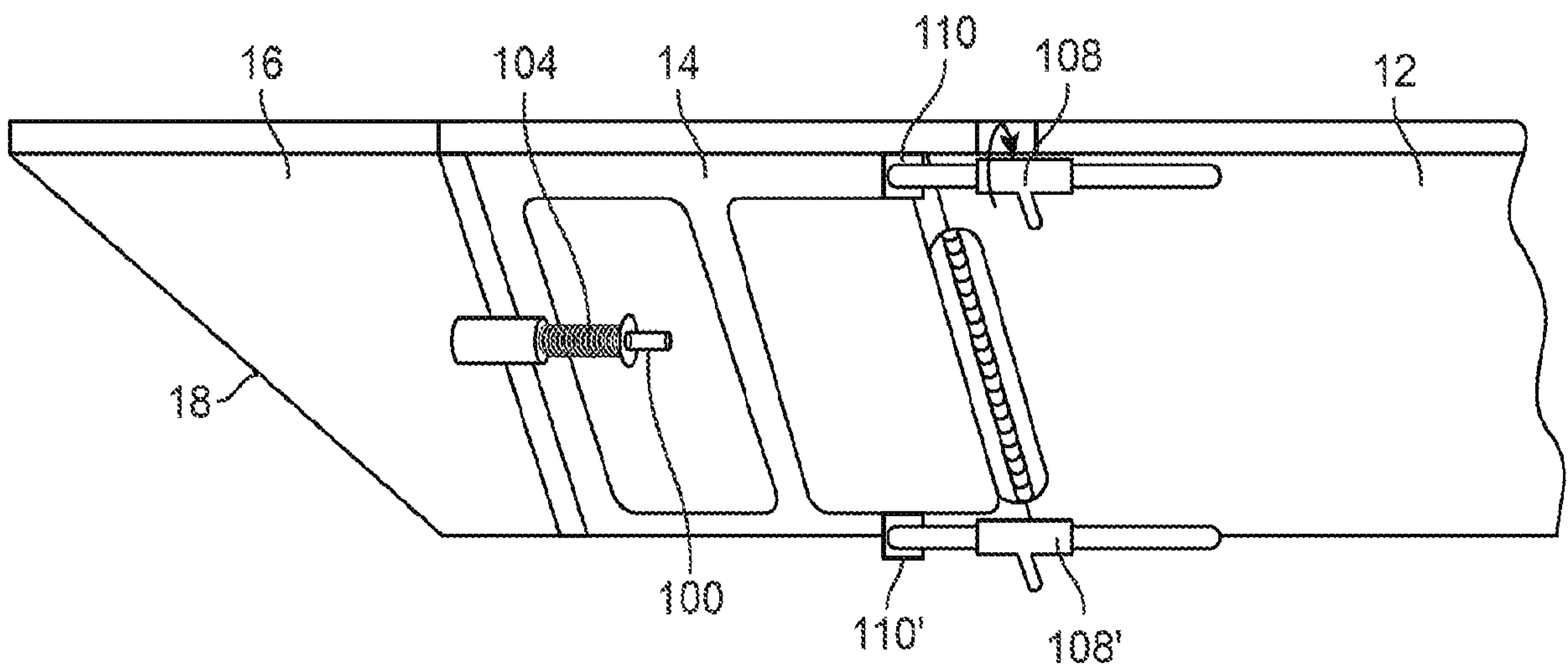

FIG. 10

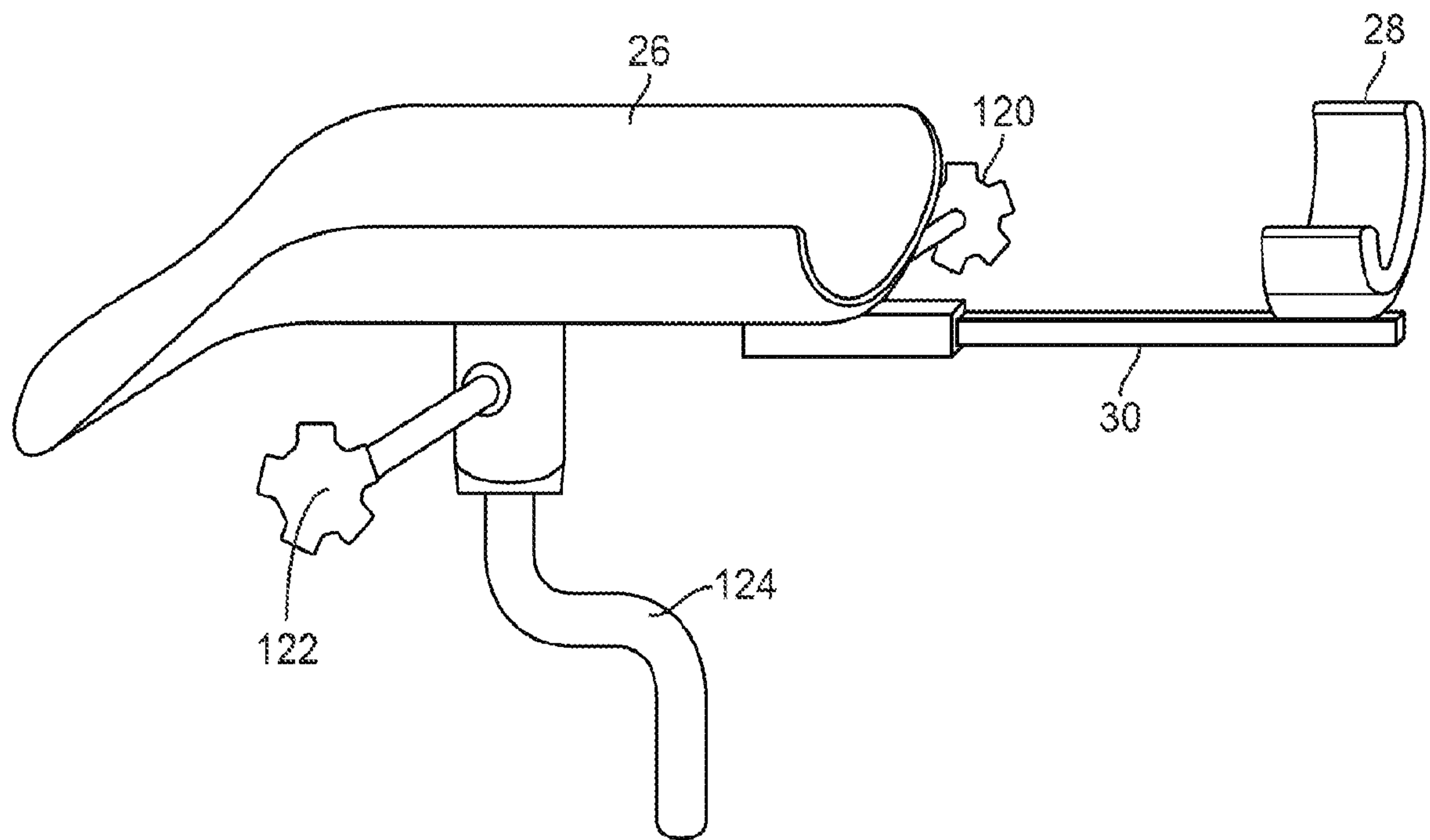

FIG. 11

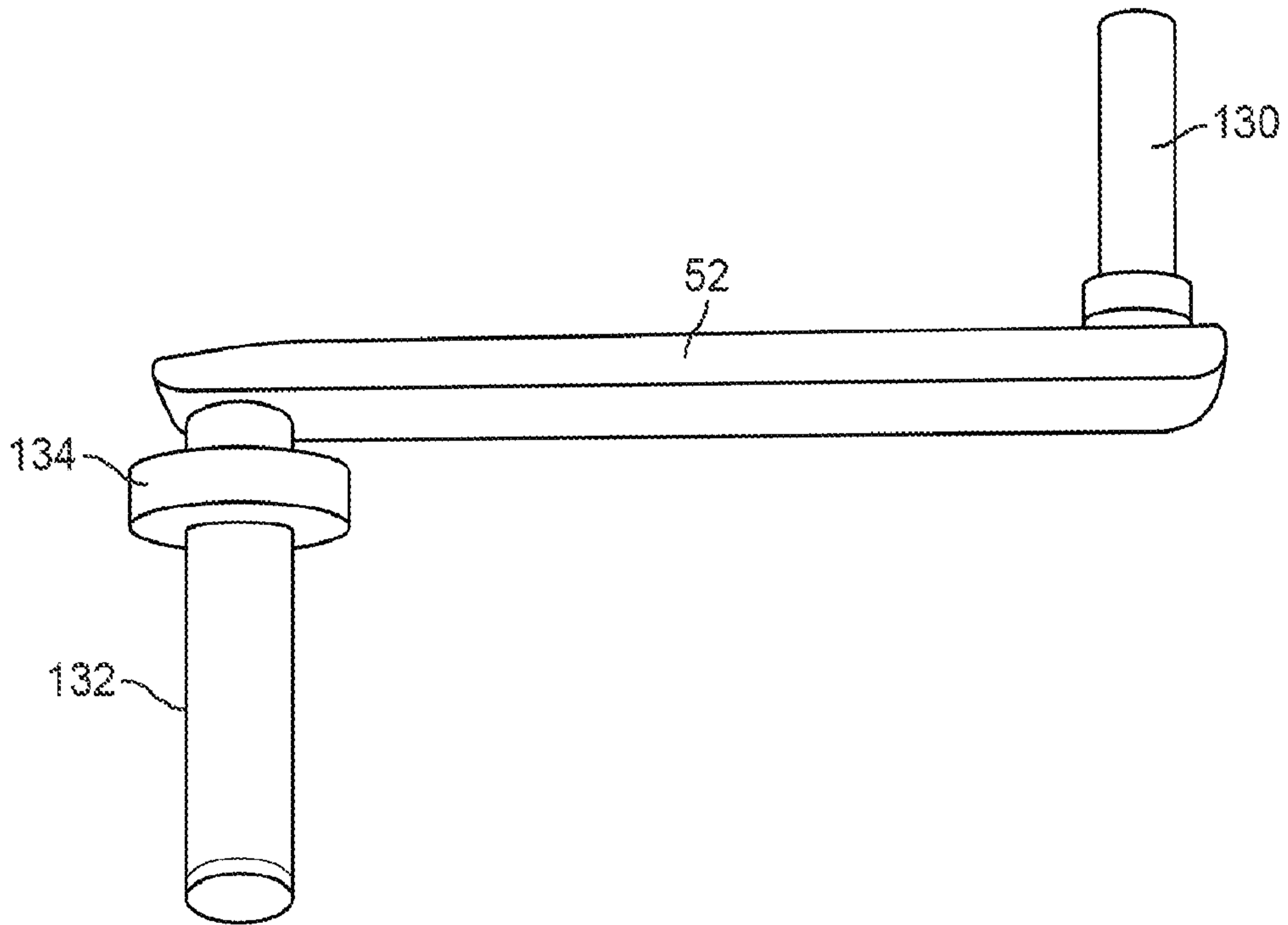

FIG. 12A

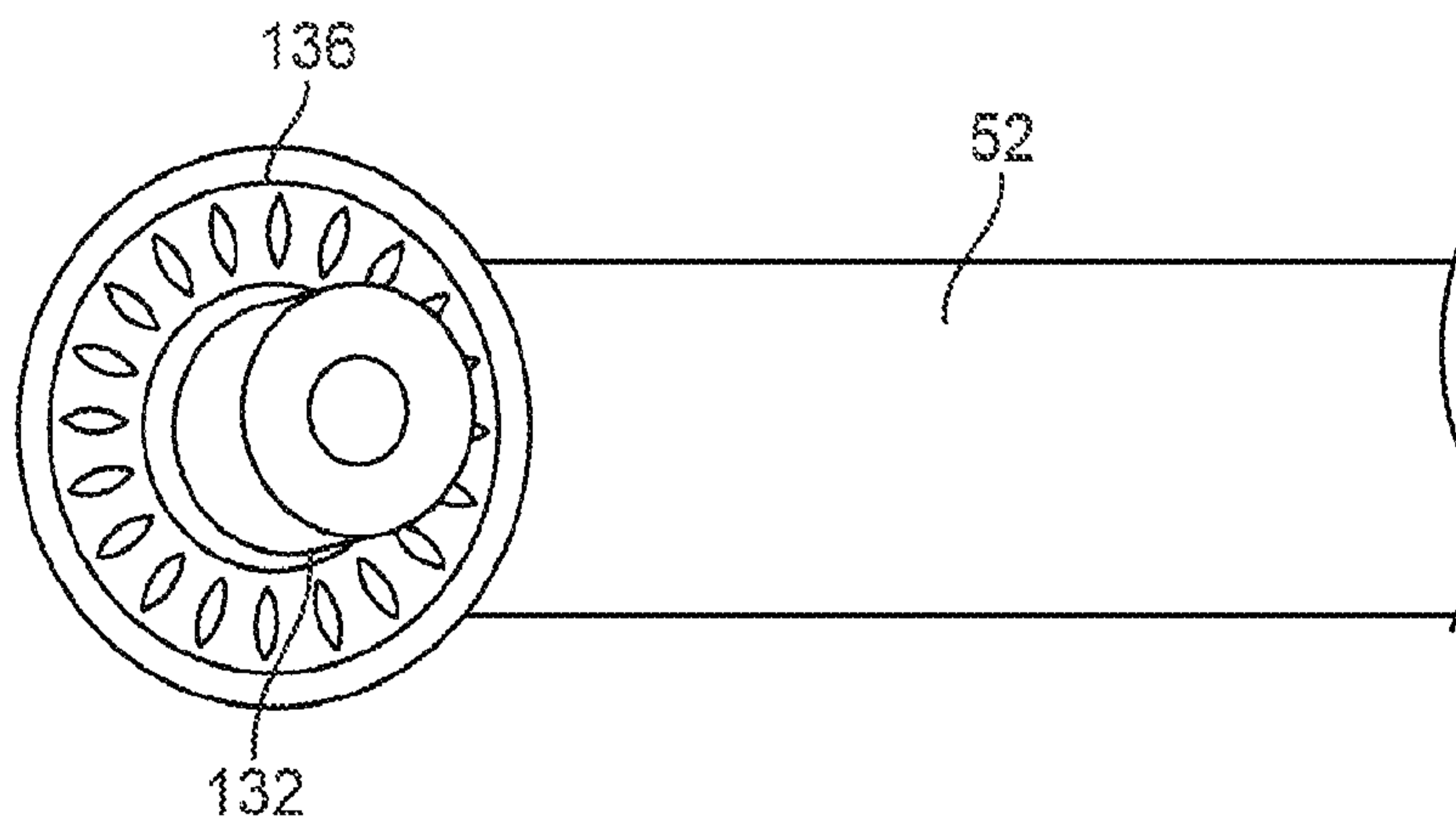

FIG. 12B

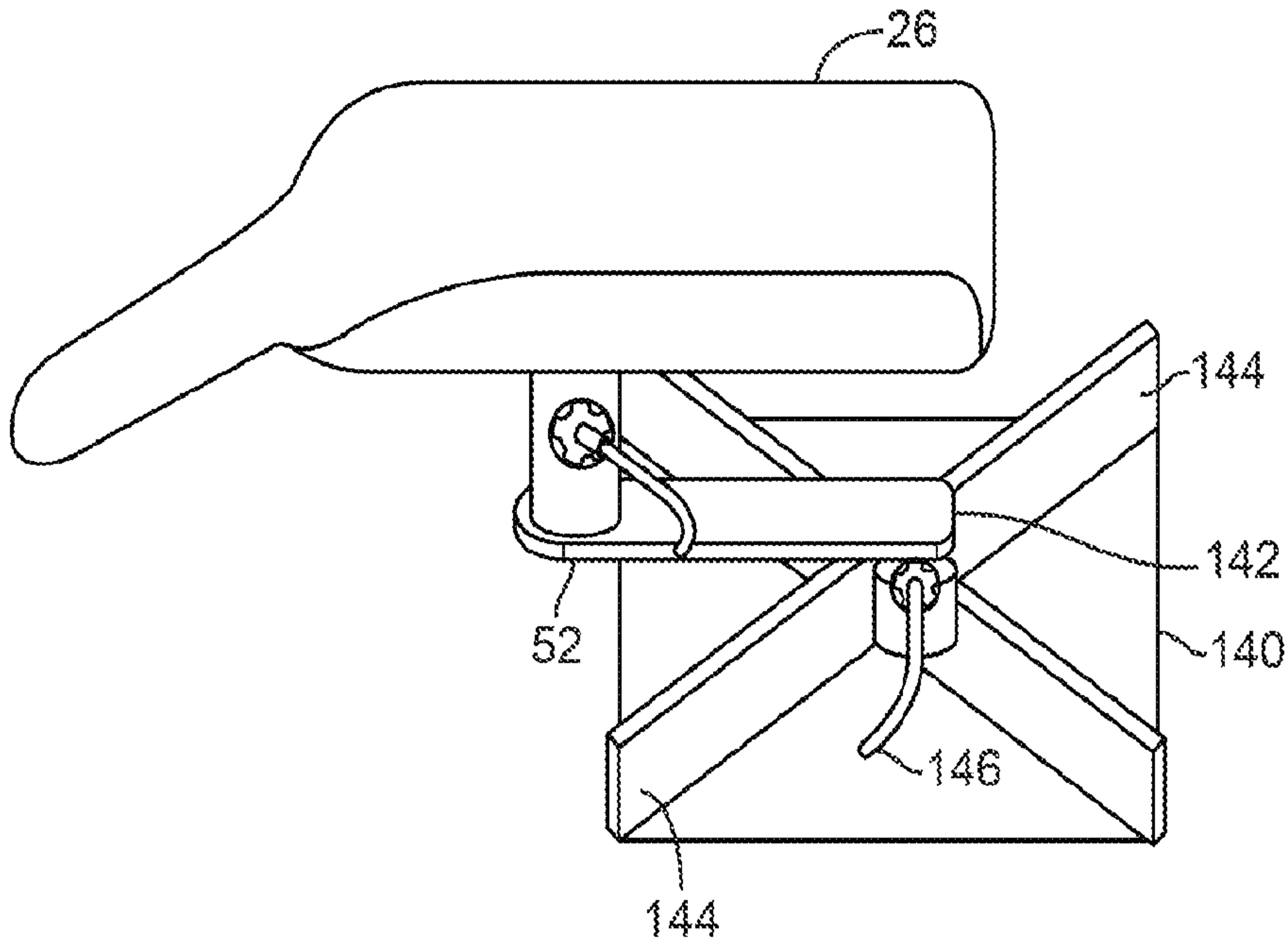

FIG. 13A

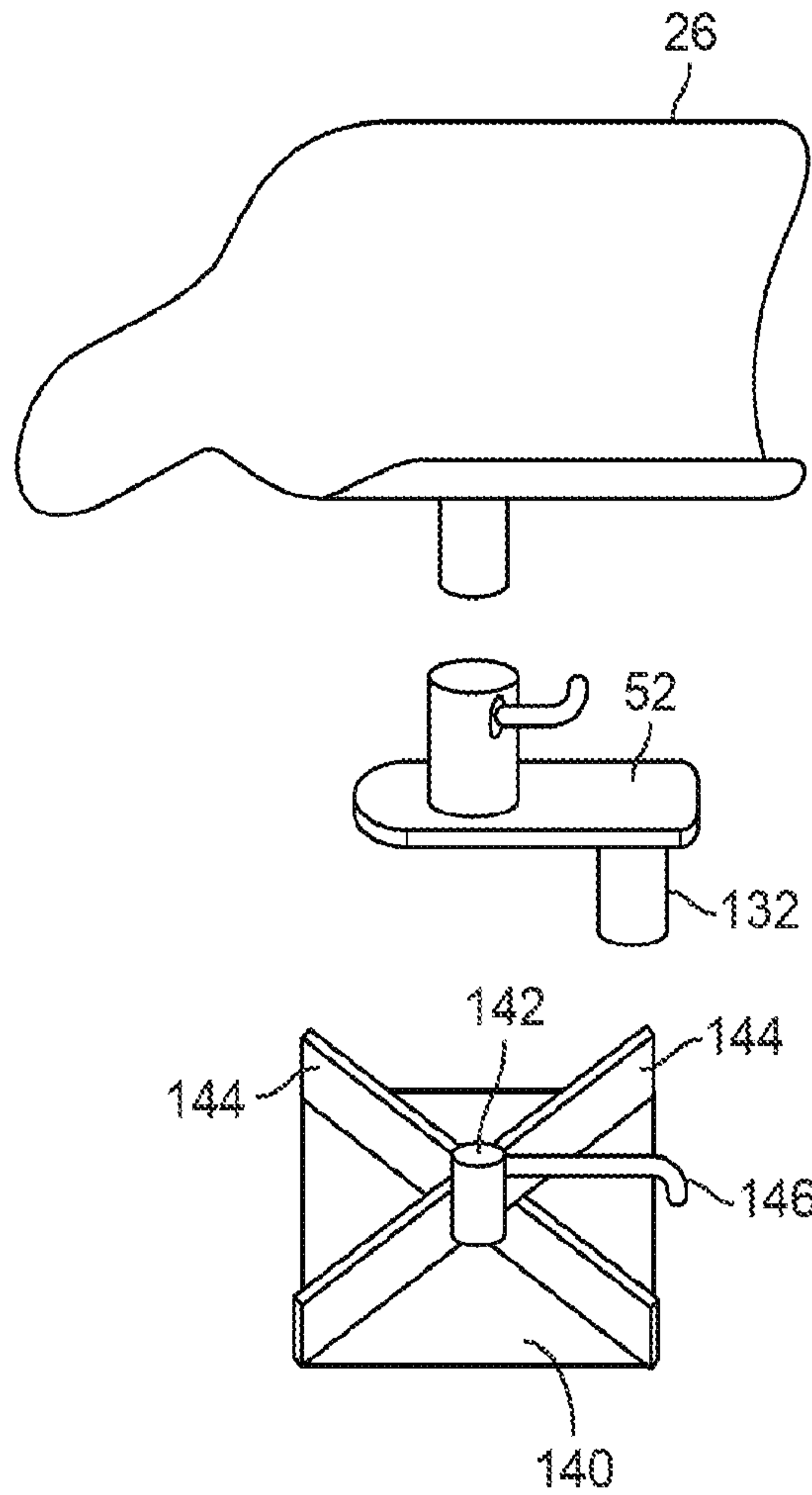

FIG. 13B

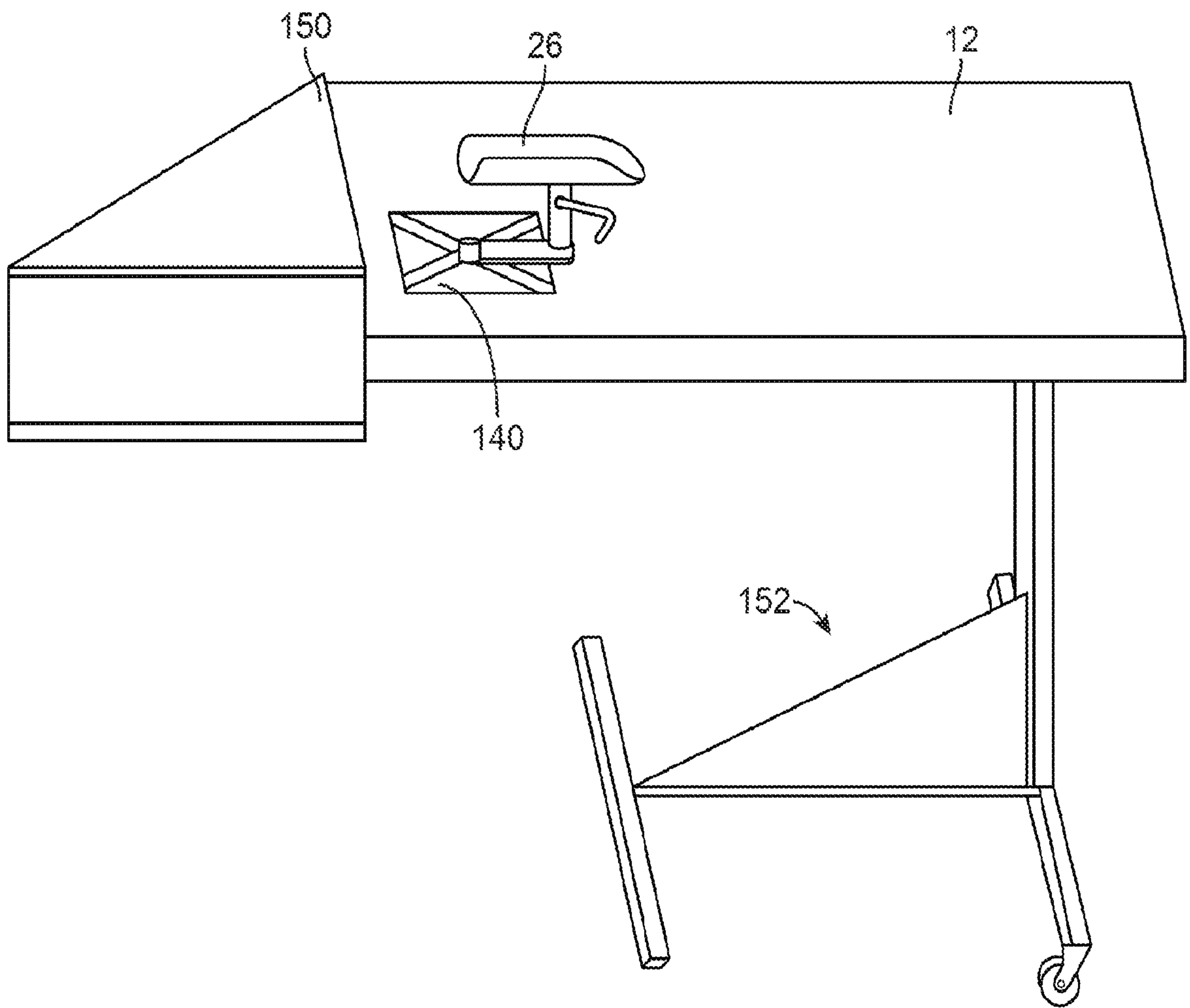
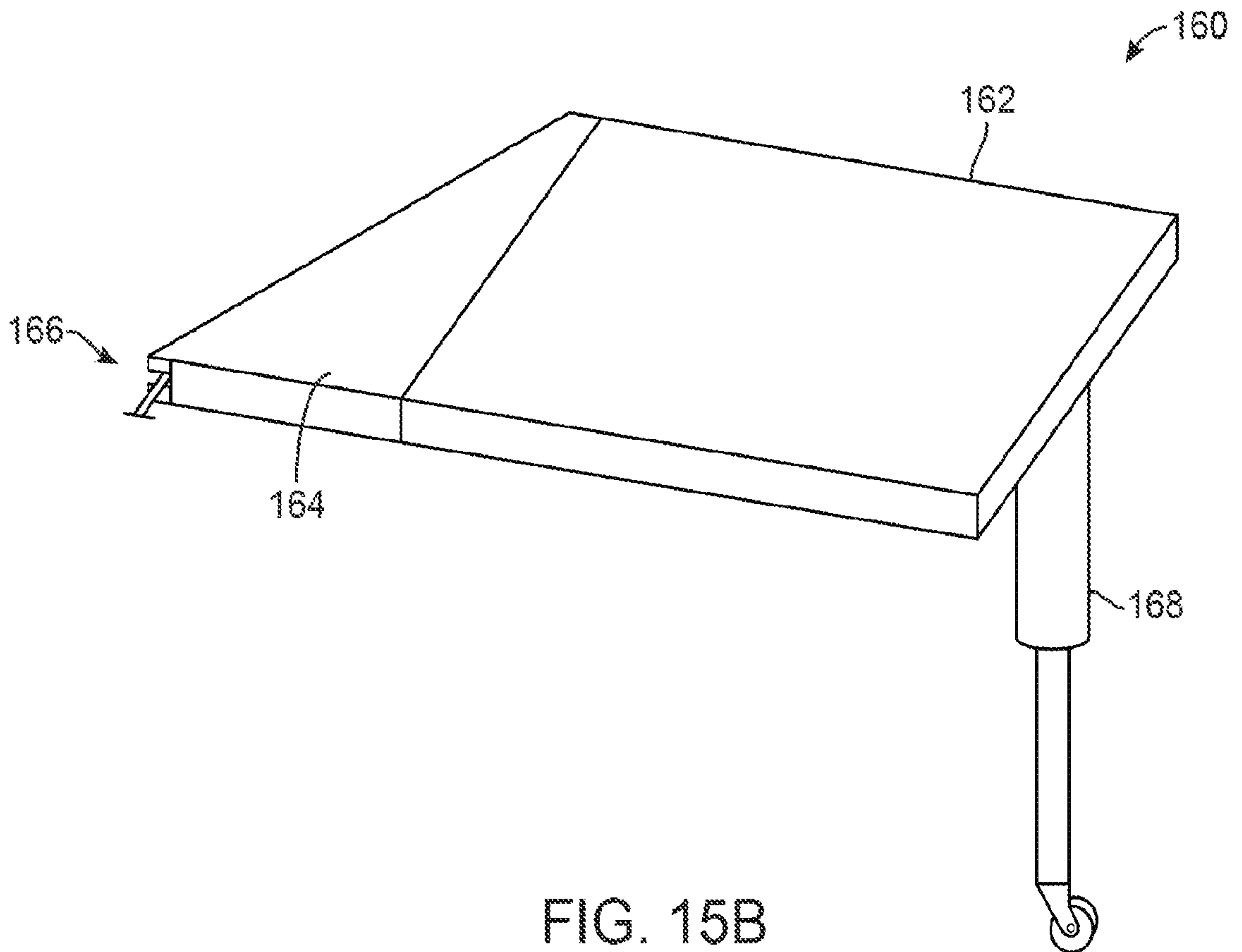
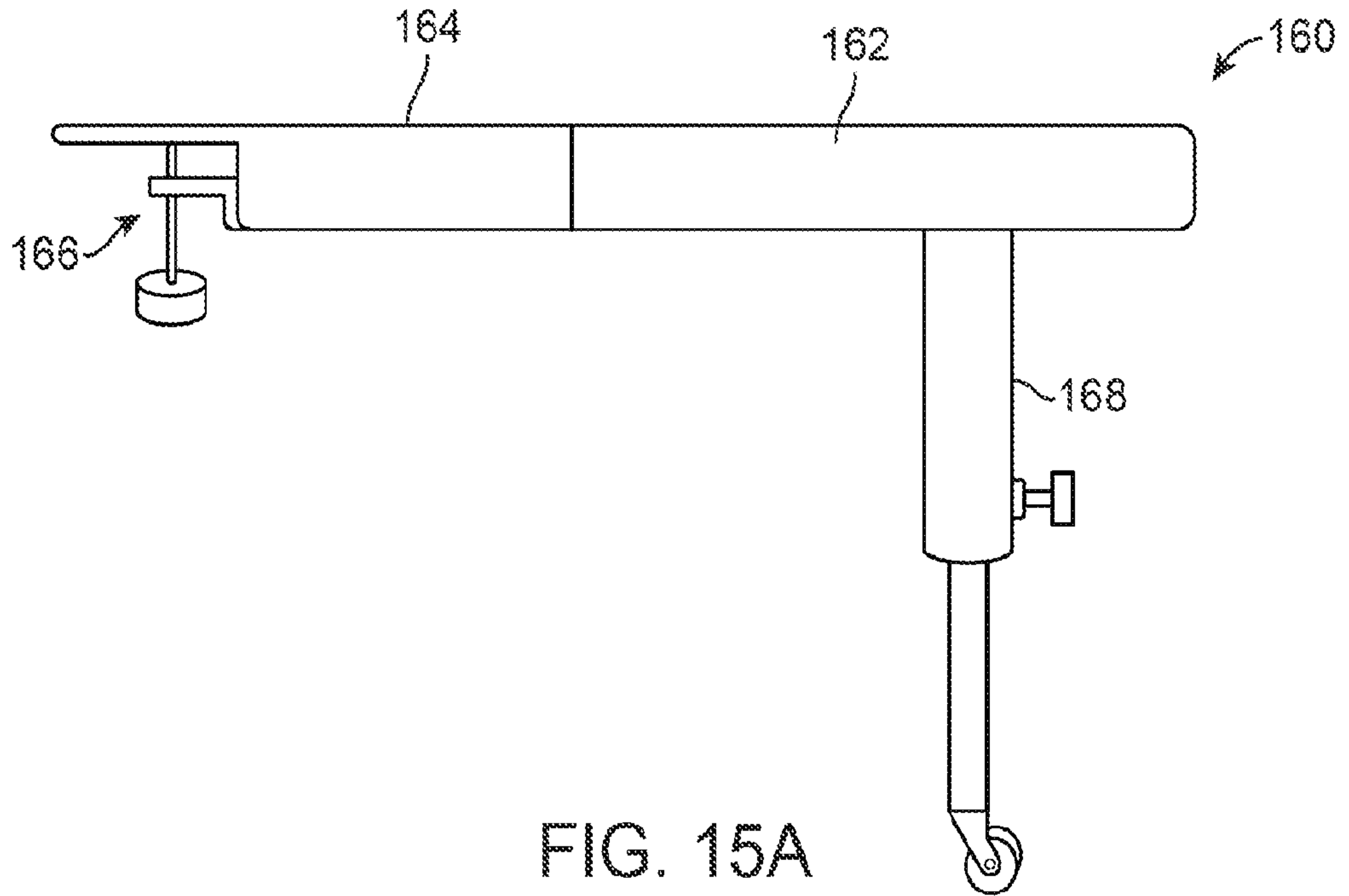

FIG. 14



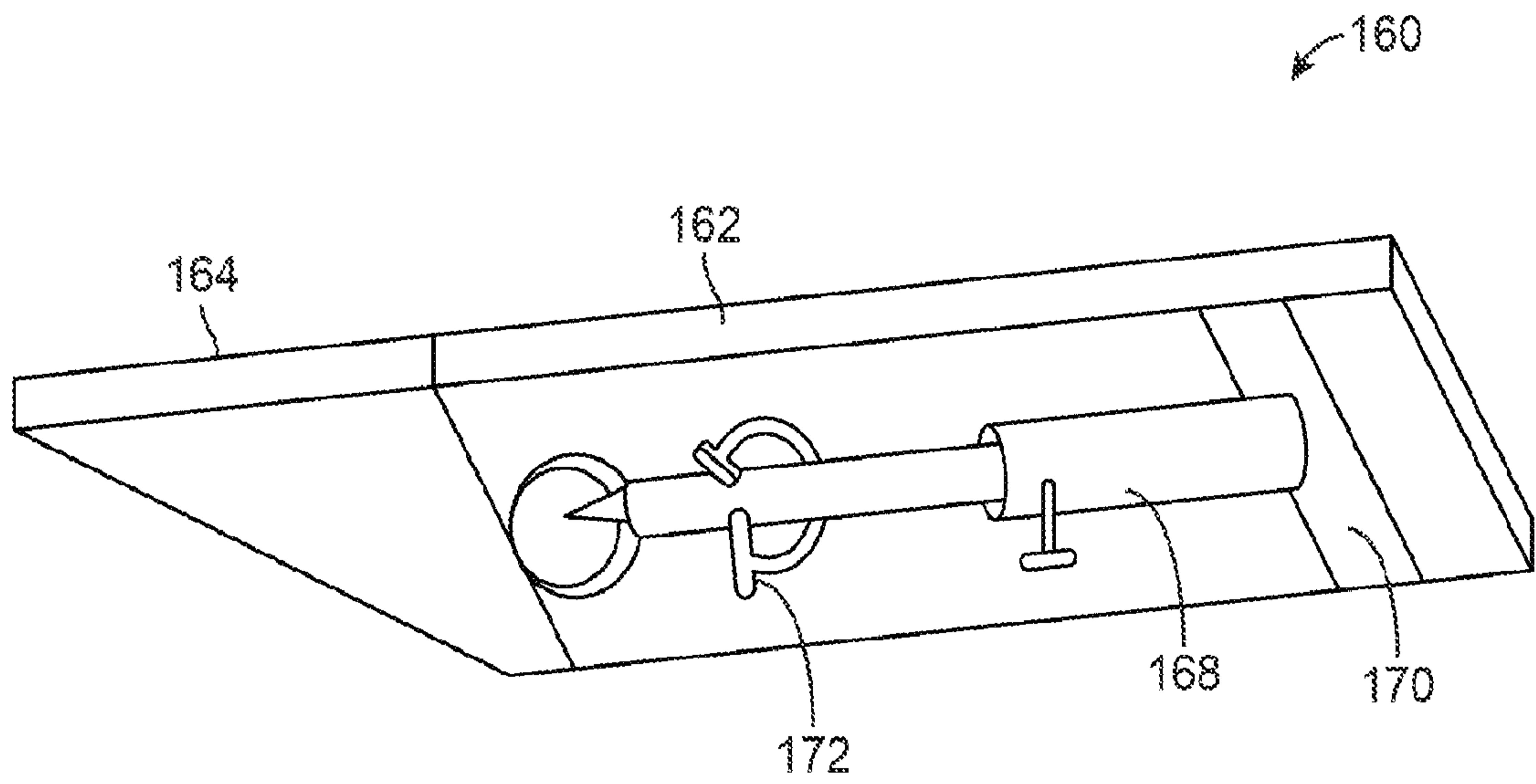

FIG. 15C

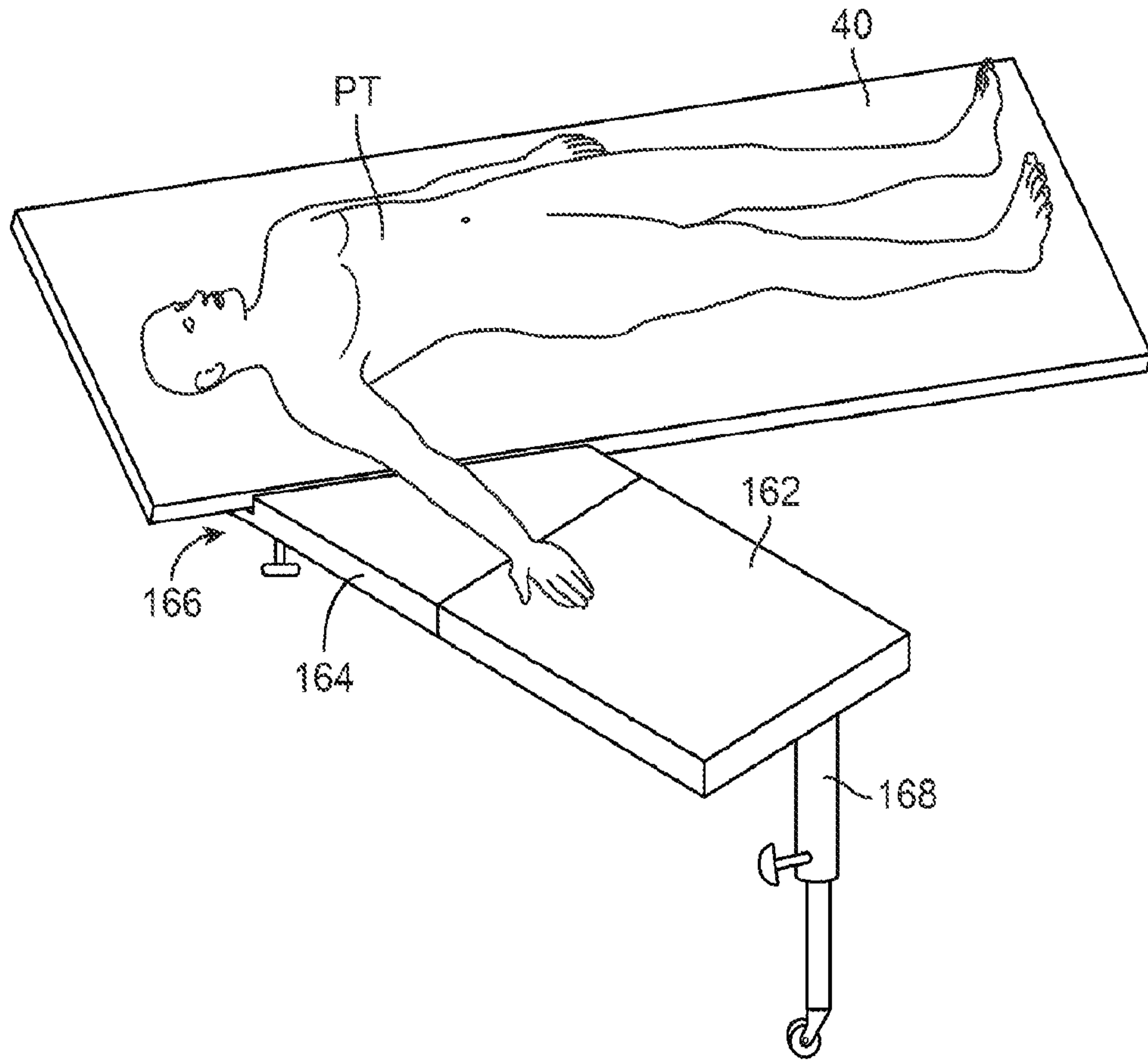

FIG. 15D

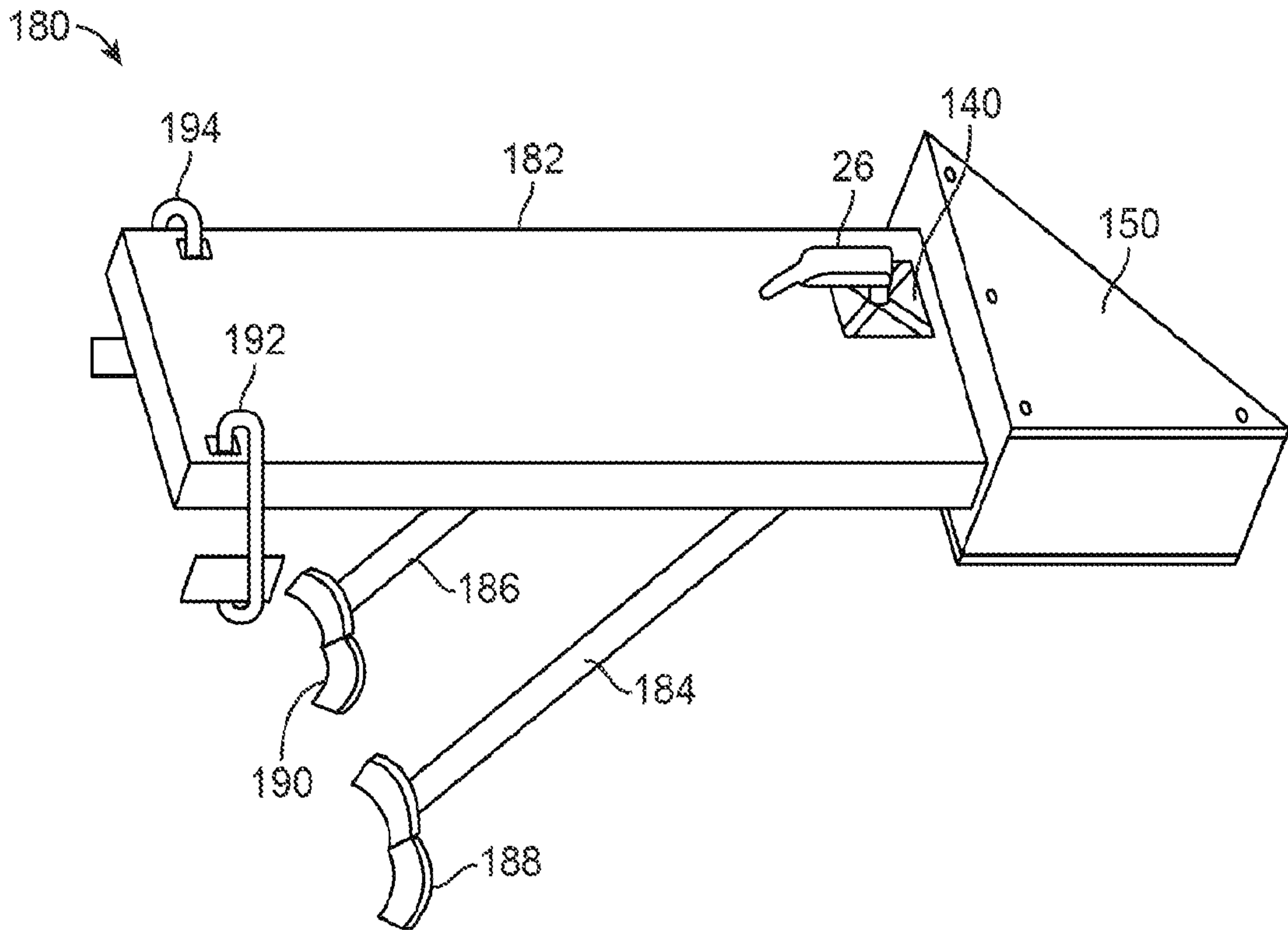

FIG. 16A

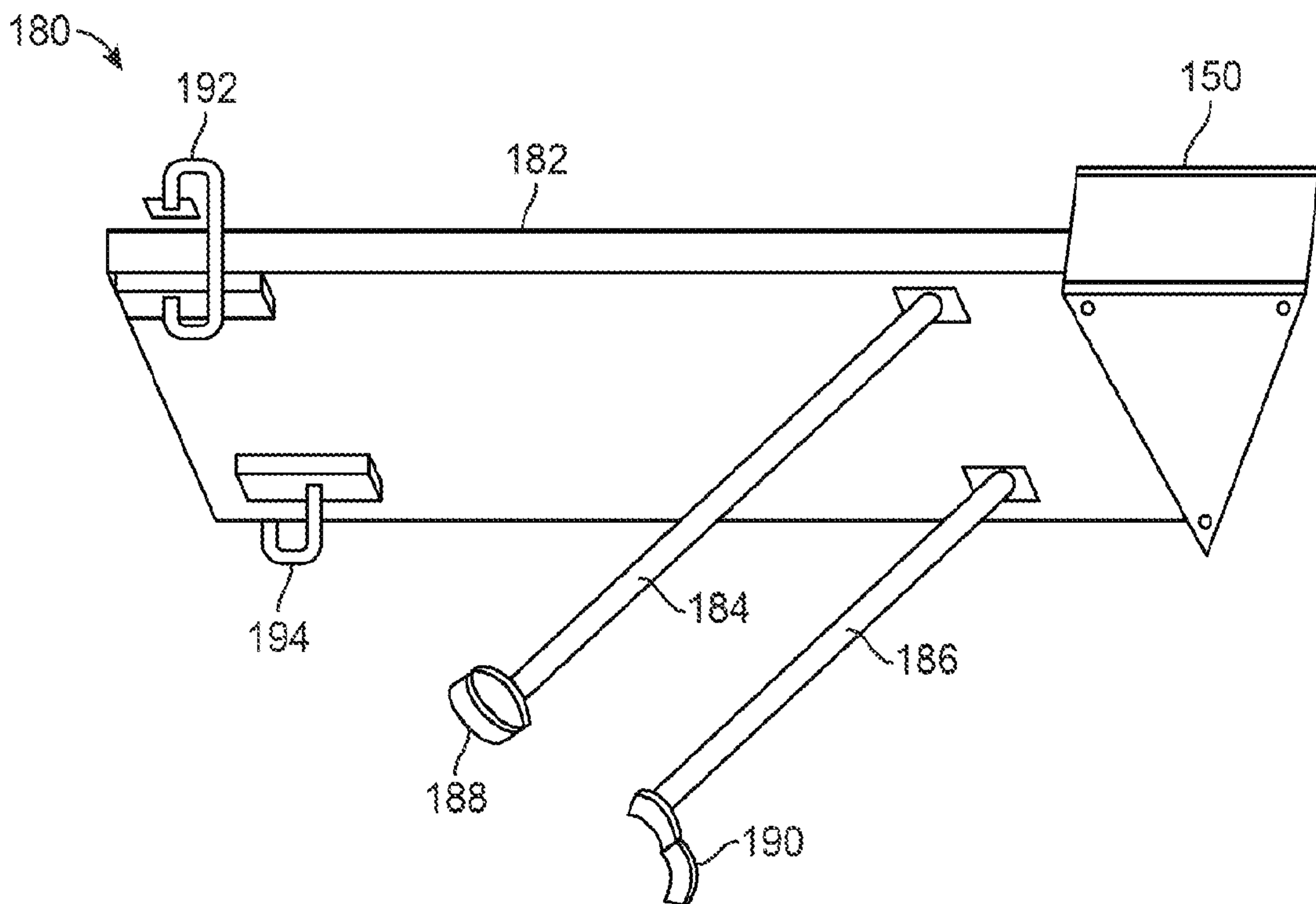

FIG. 16B

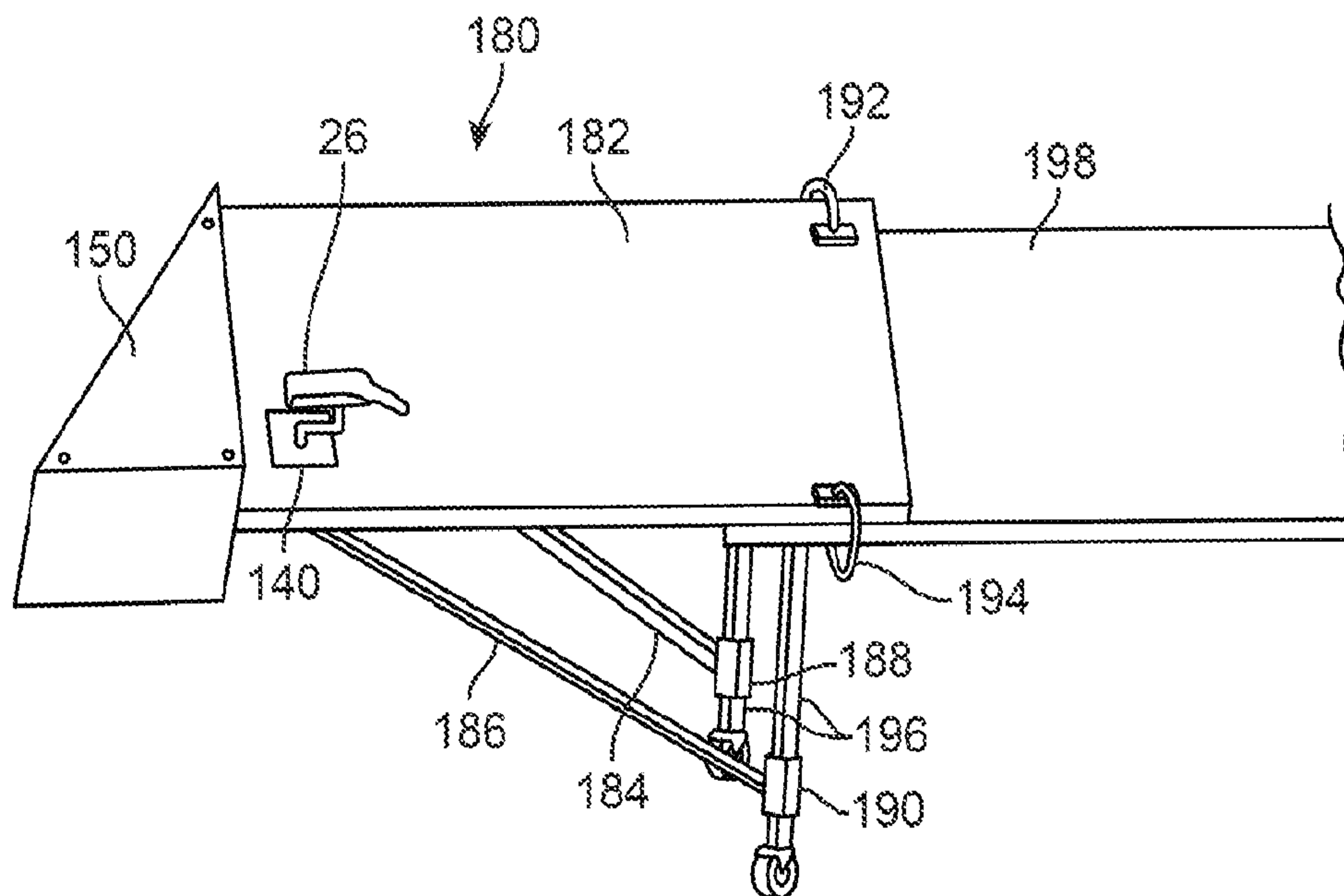

FIG. 16C

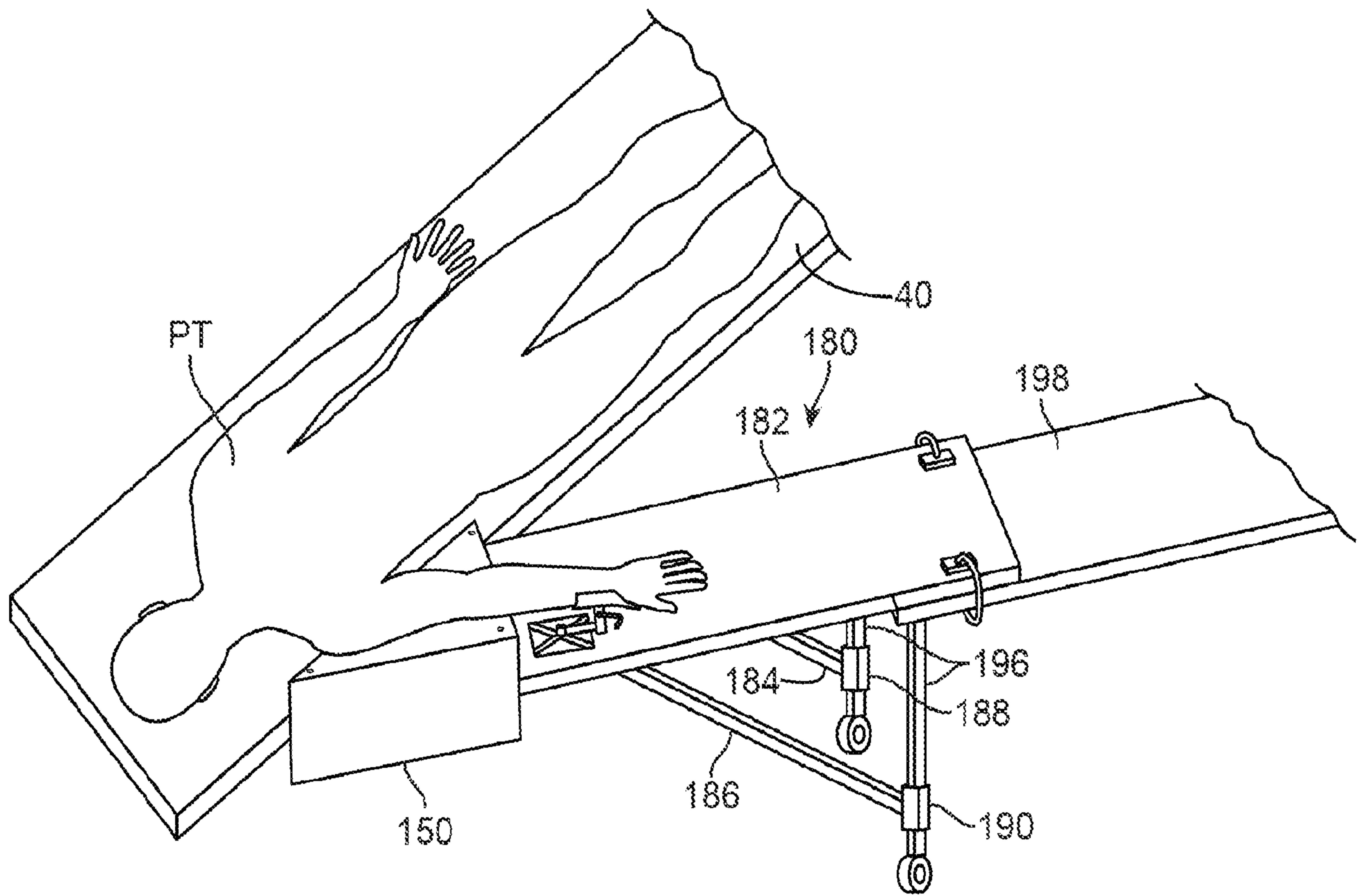

FIG. 16D

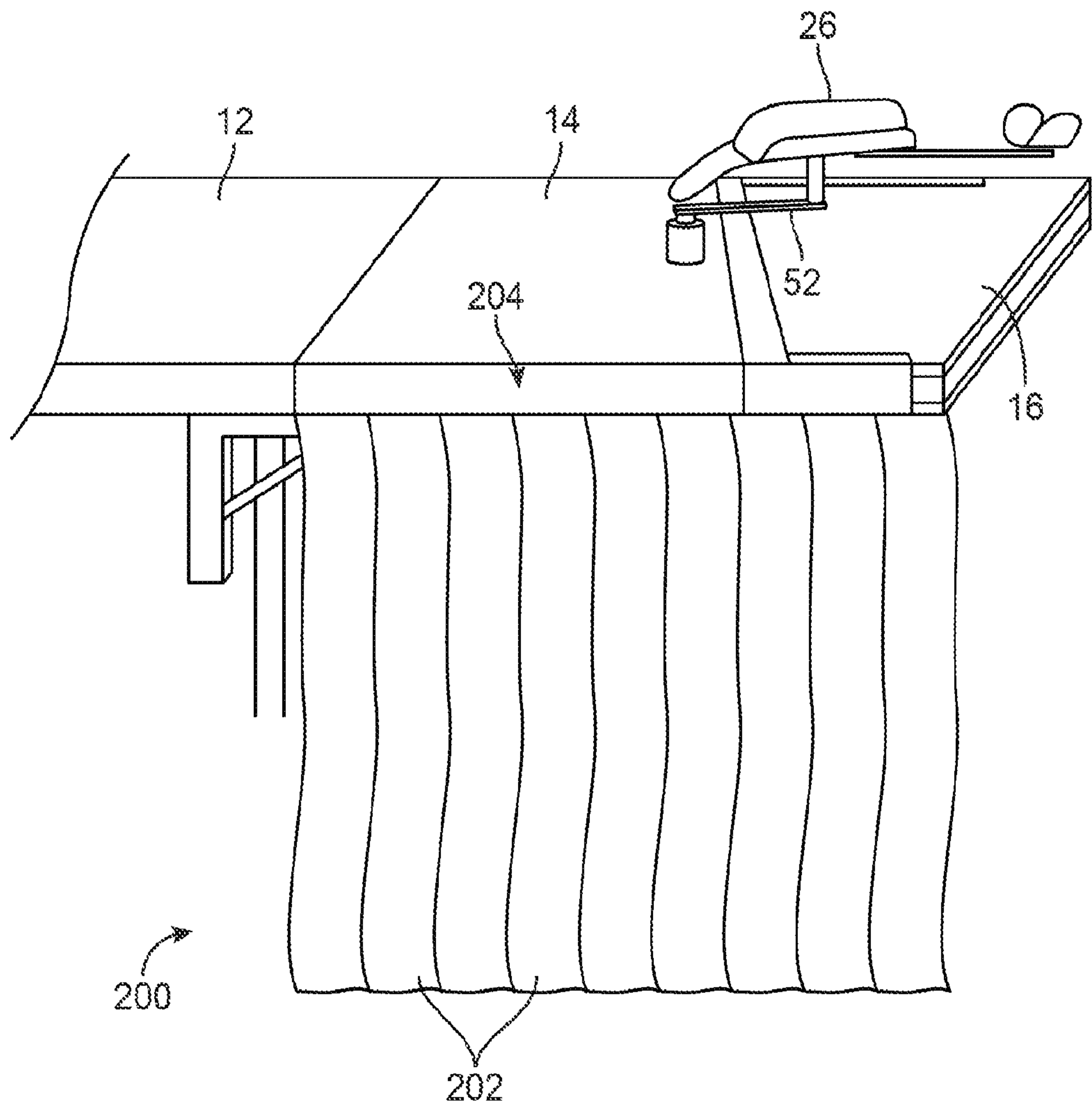

FIG. 17

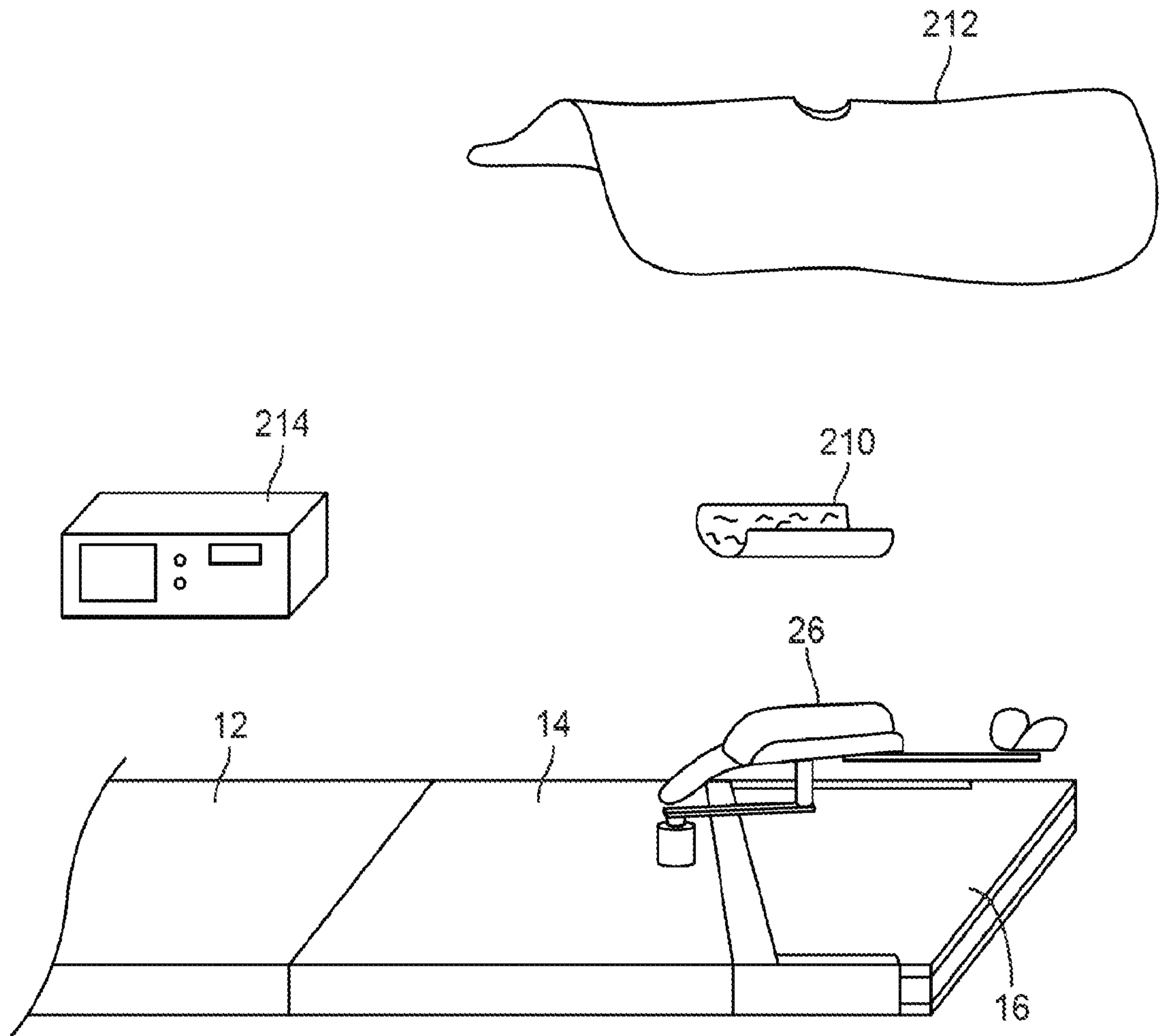

FIG. 18

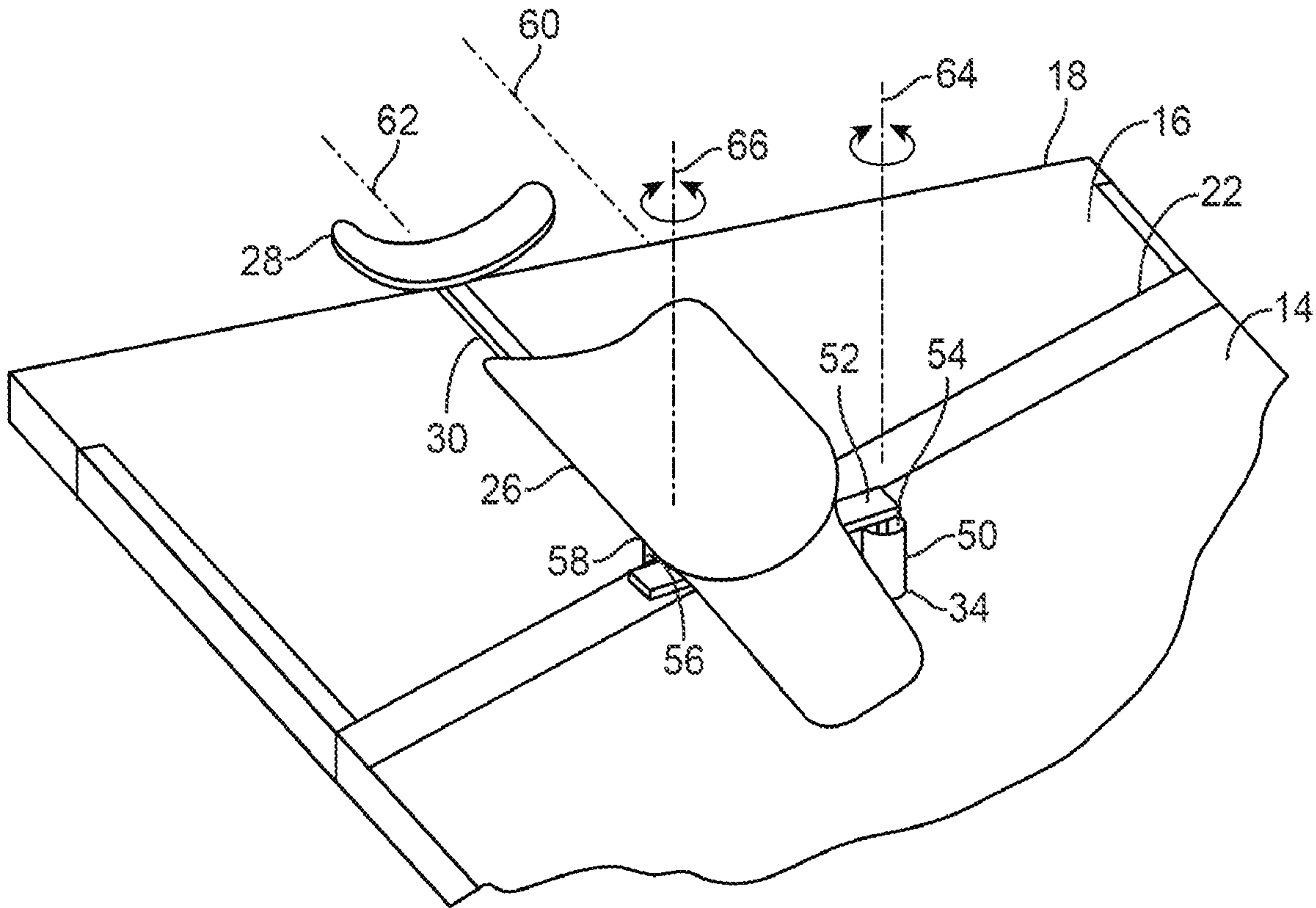

FIG. 2A