



(51) International Patent Classification:
A45D 40/26 (2006.01)

(21) International Application Number:
PCT/IB2010/050649

(22) International Filing Date:
12 February 2010 (12.02.2010)

(25) Filing Language: English

(26) Publication Language: English

(30) Priority Data:
09 50872 12 February 2009 (12.02.2009) FR
61/159,195 11 March 2009 (11.03.2009) US

(71) Applicant (for all designated States except US): L'OREAL [FR/FR]; 14 rue Royale, F-75008 Paris (FR).

(72) Inventor; and

(75) Inventor/Applicant (for US only): GUERET, Jean-Louis [FR/FR]; 27 avenue Raymond Poincaré, F-75016 Paris (FR).

(74) Agent: TANTY, François; Nony, 3 rue de Penthièvre, F-75008 Paris (FR).

(81) Designated States (unless otherwise indicated, for every kind of national protection available): AE, AG, AL, AM,

AO, AT, AU, AZ, BA, BB, BG, BH, BR, BW, BY, BZ, CA, CH, CL, CN, CO, CR, CU, CZ, DE, DK, DM, DO, DZ, EC, EE, EG, ES, FI, GB, GD, GE, GH, GM, GT, HN, HR, HU, ID, IL, IN, IS, JP, KE, KG, KM, KN, KP, KR, KZ, LA, LC, LK, LR, LS, LT, LU, LY, MA, MD, ME, MG, MK, MN, MW, MX, MY, MZ, NA, NG, NI, NO, NZ, OM, PE, PG, PH, PL, PT, RO, RS, RU, SC, SD, SE, SG, SK, SL, SM, ST, SV, SY, TH, TJ, TM, TN, TR, TT, TZ, UA, UG, US, UZ, VC, VN, ZA, ZM, ZW.

(84) Designated States (unless otherwise indicated, for every kind of regional protection available): ARIPO (BW, GH, GM, KE, LS, MW, MZ, NA, SD, SL, SZ, TZ, UG, ZM, ZW), Eurasian (AM, AZ, BY, KG, KZ, MD, RU, TJ, TM), European (AT, BE, BG, CH, CY, CZ, DE, DK, EE, ES, FI, FR, GB, GR, HR, HU, IE, IS, IT, LT, LU, LV, MC, MK, MT, NL, NO, PL, PT, RO, SE, SI, SK, SM, TR), OAPI (BF, BJ, CF, CG, CI, CM, GA, GN, GQ, GW, ML, MR, NE, SN, TD, TG).

Published:

- with international search report (Art. 21(3))
- before the expiration of the time limit for amending the claims and to be republished in the event of receipt of amendments (Rule 48.2(h))

(54) Title: A DEVICE FOR APPLYING A COSMETIC COMPOSITION

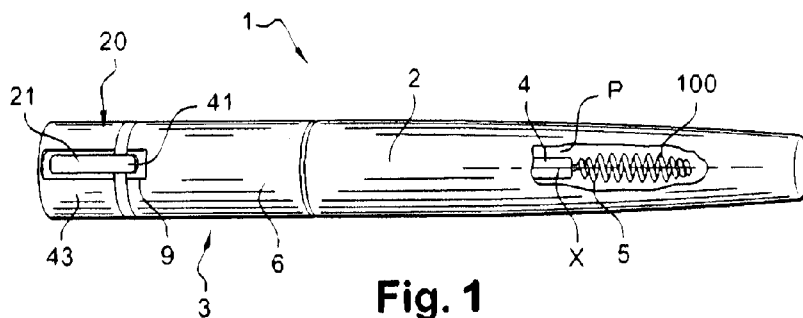

Fig. 1

(57) Abstract: The invention relates to a device for applying a cosmetic on human keratinous material and/or for finishing off the application of makeup and/or for massaging, the device comprising: • a vibration source (20); and • an applicator member exposed to the vibration of the vibration source, the member including a spring (100) having at least a region thereof for coming into contact with said keratinous material.

WO 2010/092551 A1

A DEVICE FOR APPLYING A COSMETIC COMPOSITOIN

The present invention relates to devices for applying a cosmetic composition on human keratinous material, e.g. the skin, the lips, the nails, the eyelashes, the eyebrows, or hair, and it relates in particular to devices including a spring having at least a region that is to come into contact with said keratinous material.

The invention preferably relates to applicators other than mascara applicators.

Application FR 2 822 656 discloses an applicator for applying mascara on the eyelashes, the applicator including a helical spring with a portion that forms the stem of the applicator and another portion that is flocked constituting the applicator member.

Patent EP 1 185 186 B1 also discloses a twisted-core mascara brush with a spring arranged coaxially around the core so as to modify the distribution of the bristles on the brush.

Patent US 7 025 068 B2 describes a twisted-core mascara brush inserted inside a double-helix helical spring.

Devices in which the applicator member includes a spring are nevertheless not widely distributed compared with those having twisted-wire brushes and/or brushes or combs made by injection-molding a thermoplastic material.

It is also known, from publications WO 2006/09343 or FR 2 904 923, to expose twisted-core brushes or other applicator members to vibration.

There exists a need to further improve devices for applying a cosmetic composition on human keratinous material, e.g. to the skin or the lips, or to keratinous fibers such as the eyelashes or hair.

The invention preferably relates to applicators other than mascara applicators.

The invention seeks to satisfy this need, and does so, in first exemplary embodiments, by means of a device

for applying a cosmetic composition on human keratinous material and/or for finishing off the application of makeup and/or for massaging, the device comprising:

- a vibration source; and
- 5 • an applicator member exposed to the vibration of the vibration source, the member including a spring having at least a region thereof for coming into contact with said keratinous material.

The term "coming into contact with keratinous material" should be understood as meaning that the spring may come into contact with keratinous material via its outside surface, regardless of whether its outside surface is defined by a metal from which a wire of the spring is made, or by a coating of flocking, or by a sheath covering the wire.

In these exemplary embodiments of the invention, the combined use of a vibration source and an applicator member including a spring, makes it possible to take advantage of the elastically deformable nature of the spring in order to increase the amplitude of the movements of the applicator member under the effect of the vibration. This makes it possible to obtain an applicator member that is capable of being more effective in application of the composition and/or suitable for performing an additional action on the keratinous material, e.g. massaging.

The vibration frequency may be selected so that the spring enters into resonance at said frequency, thereby maximizing the amplitude of the vibration of the spring.

The spring may retain the composition by capillarity between its turns, where appropriate.

The invention makes it easy to adapt the applicator member to the nature of the composition and to the treatment to be performed.

The device according to exemplary embodiments of the invention is configured for applying a composition and not for epilating.

The spring may be made of a single filament, or of a plurality of filaments. For example, the spring may comprise one, two, or three metal wires. The spring may be made from a single wire having two branches that are folded to form a hairpin-shape. The spring may extend to a distal end of the device. The wire may be made of stainless steel, e.g. of 304, 308, or 316L stainless steel. The spring may have turns that touch one another. When the wire of the spring is flocked, then the length of the bristles of the flocking may be sufficient to ensure that the bristles of two adjacent turns interpenetrate. For example, it is possible to have flocking bristles of a length that is greater than half the pitch between the turns.

The applicator member may have a single spring or a plurality of springs, e.g. two springs that are at least partially interleaved one in the other. Both springs may come into contact with keratinous material. In a variant, only one of the two springs comes into contact with keratinous material. The two springs may be wound in opposite directions. The two springs may have characteristics that are different in terms of shape, the wire used, or flocking. The shapes of the two springs may be different.

The spring may be free at one end, and the amplitude of the vibration may be at a maximum at said end, for example. The free end may be the distal end of the spring, for example.

In a variant, the device may be configured so that the spring is limited in its movements in at least one direction, in particular at its distal end.

For example, the spring may include a core extending longitudinally inside the spring, thus making it possible to limit the movements of the spring in a direction perpendicular to its longitudinal axis. The spring may be mounted with greater or smaller clearance around said core. One end of the spring may be limited in the amount

of movement it can perform, in at least one direction, by the core.

The core may be smooth or it may carry one or more projecting elements, which elements may for example
5 comprise teeth molded integrally with the core, e.g. out of thermoplastic material. The core may also be injection-molded onto the bristles or it may be twisted, e.g. it may be formed by two branches of a metal wire that are twisted together on the bristles. The core may
10 be pierced by one or more composition outlet orifices.

The projecting elements carried by the core may extend between the turns of the spring and they may project outside the applicator member, or in a variant they may remain set back from the turns of the spring
15 without projecting out therefrom.

The spring is preferably mounted on the core, or the brush, with a possibility of oscillating under the effect of vibration from the vibration source, in particular of oscillating axially.

The spring may be helical, with the diameter of the turns being constant or varying. The term "turn diameter" should be understood as meaning the diameter of the circle that is circumscribed around a turn when it is observed in projection onto a plane perpendicular to the
20 axis of the spring. For example, over at least half the length of the spring, the turns may be of varying diameter, optionally passing through an extremum.

The turns may be circular or they may be of some other shape, e.g. substantially polygonal, in particular square, or else elliptical. The wire may describe a path that is seen as turning clockwise or counterclockwise on going towards its distal end, and while looking from the proximal end towards the distal end.
30

When the turns are of varying diameter, their
35 diameter may, for example, decrease towards the distal end of the spring, thus making it possible to define an envelope surface for the applicator member that is

rounded or tapering towards the distal end of the applicator member, for example. A rounded surface may be advantageous, in particular when the applicator member is to come into contact with the skin or the lips.

5 Over at least a fraction of its length, the spring may have turns that are touching. All of the turns of the spring may be touching, or in a variant only a fraction of the turns need be touching. The spring may have at least two non-touching turns, e.g. in order to
10 make a greater amount of movement possible under the effect of vibration.

The axial pitch between the turns may be constant or varying. The turns are preferably closer together at the front and rear ends of the spring (i.e. at the distal and
15 proximal ends thereof).

Thus, the pitch between the turns may be at a maximum between the proximal and distal ends of the spring.

The spring may also define an envelope surface
20 having at least a fraction that is outwardly concave, and/or a fraction that is outwardly convex.

In exemplary embodiments, the spring may include over at least a fraction of its length an alternation of turns of outside diameter respectively greater than and
25 less than an intermediate value. This may make it possible to form a succession of grooves in the surface of the applicator member, which grooves are capable of combing the eyelashes, e.g. like a comb.

The spring may be made using a metal wire or a
30 synthetic filament or a metal wire that is sheathed in paint or in thermoplastic material, it being possible for the spring to be flocked, at least in part. The presence of flocking may improve the distribution of the composition on the spring and may facilitate its transfer
35 onto keratinous material. The spring may comprise a wire sheathed in synthetic material, e.g. thermoplastic

material, in particular material that is colored or transparent.

The flocking may be of any kind, including natural. The flocking may be magnetizable and/or electrically
5 conductive. The spring may be a single piece and made of the same material as the stem of the applicator supporting the spring, where appropriate.

The vibration may be oriented in various ways relative to the longitudinal axis of the spring, in
10 particular it may be oriented parallel to said longitudinal axis or transversely relative thereto, e.g. perpendicularly to the longitudinal axis, depending on the makeup or care action to be performed and the nature of the keratinous material being treated.

As mentioned above, at least a fraction of the
15 length of the spring may surround a brush, which brush may have a twisted core or an injected core, or it may surround a flocked endpiece, a block of foam, or of some other cellular and/or porous material, or a block of
20 makeup, the surrounded element optionally coming directly into contact with the keratinous material when it is in use.

Such a configuration enables the applicator to be
25 loaded with more composition, thereby enabling it to be used for longer.

In preferred exemplary embodiments, the spring surrounds a foam.

The spring may also surround a diaphragm, and where appropriate, the diaphragm may be flocked or pierced by
30 one or more composition-dispensing orifices.

The device may include a housing for receiving the applicator member while not in use. By way of example, the housing may be defined by a reservoir containing the composition for application, e.g. mascara. Under such
35 circumstances, the applicator member may become loaded with composition while not in use. By way of example, the applicator member is mounted at the end of a stem and

the device may include a wiper member for wiping the stem and/or the applicator member on being removed from the reservoir. The wiper member and the stem may be fitted in the neck of the container, said wiper member possibly
5 being rigid, e.g. being made of polypropylene (PP) or polyethylene (PE), or flexible, e.g. being made of elastomer, in particular of thermoplastic elastomer. After wiping, the composition may remain contained inside the spring, or even between its turns. The stem may be
10 made of thermoplastic material. The applicator member may be fastened to the stem in various ways. The proximal end of the spring may for example be inserted in a housing in the stem or it may be clamped onto the stem. The spring may also be fastened by the stem being molded
15 onto the spring or in some other way, e.g. using adhesive, heat-sealing, or stamping the stem or the spring. The spring may include a fraction having touching turns, which is fastened to the stem.

The spring may also be fastened on a support. It
20 may be fastened by molding the support onto the spring or in some other manner, e.g. by adhesive, heat-sealing, or stamping the support or the spring. The spring may include a fraction having touching turns, which is fastened to the support. The applicator member may be
25 received in a housing that is separated from the reservoir containing the composition by a wall that is permeable to the composition, which wall is open, permanently or otherwise. By way of example, the wall may be a wall of thermoplastic material pierced by one or
30 more composition feeding orifices. When the applicator member is received in the housing, it may optionally be compressed. For example, the length of the spring may be shortened when the applicator member is in the housing, e.g. by at least 10% or even 20% or 30%. The housing may
35 be fed with composition by a pump or a valve, by the composition flowing under gravity, or by the composition

being pressurized, e.g. with the help of a piston or by squeezing the container.

In exemplary embodiments, the applicator member is received in a housing when not in use, and one end of it comes to bear against a surface that is loaded in composition. By way of example, said surface may be defined by a face of a block of said composition, which may for example be in the form of a powder that is compacted or molded. When the applicator member is returned into the housing, the ability of the spring to extend may serve to compensate for the block of composition being used up. The vibration of the spring may enhance loading with composition and/or avoid an excess amount of composition being taken.

In exemplary embodiments, the device includes a handle surface for use during application of the composition, which surface is not defined by the spring itself. In variant exemplary embodiments, the spring defines a handle surface for the device during application. By way of example, the spring may then surround the vibration source, at least in part. The handle surface may be defined by a portion of the spring that presents touching turns.

The applicator member may be mounted so as to be incapable of rotating on a support of the device, or in a variant it may be mounted to rotate on a support of the device, e.g. about an axis of rotation coinciding with the longitudinal axis of the spring. When the applicator member is mounted to rotate on a support, the applicator member may, for example, be mounted on a stem and/or between two tines of a fork of the device. The spring may be adjacent to one end of the above-mentioned stem, with the other end of the stem being connected to a handle member. When the applicator member is mounted to rotate, the device may for example serve to apply a composition on the eyelashes, on keratinous material, or it may serve to provide a massage effect.

The spring may be mounted to rotate on a support, e.g. on a stem or on a device having a reservoir containing the composition for application.

When the applicator member is mounted to rotate
5 between two tines, it may for example turn on being moved in contact with the skin, under the effect of friction with the skin, thereby exerting a massage effect thereon. Under such circumstances, the spring may optionally be supported by a shaft extending between the tines.

10 The spring may be compressed axially between two surfaces of the device. Where appropriate, the degree with which the spring is compressed may be adjusted by the user acting on an adjustment member.

The longitudinal axis of the spring may be
15 rectilinear, e.g. it may coincide with the longitudinal axis of the device or it may extend transversely to the longitudinal axis of the device. The longitudinal axis of the spring need not be rectilinear, for example it may be curved along a circular arc, the longitudinal axis of
20 the spring possibly being capable of turning through more than one-fourth of a turn, e.g. through half a turn. Where appropriate, the two ends of the spring may meet.

The applicator member need not be mounted at the end of a stem, for example it may be mounted on the neck of a
25 container, with the composition for application being dispensed inside the spring from the container, for example. The composition may be expelled between the turns of the spring or from the end thereof.

The spring may also be mounted on a fastener skirt
30 that is connected to a handle portion, which handle portion may be configured for fastening on a container when not in use, e.g. for the purpose of closing the container in leaktight manner while not in use. By way of example, the diameter of such a skirt may be greater
35 than or equal to one centimeter. The greatest diameter of the spring may be greater than or equal to 1.5 times the diameter of the skirt, for example.

The device may include the composition for application in liquid or solid form, e.g. a cream, a gel, a powder that is free or compacted, or a cast block. The supply of composition may be secured to the applicator member when it comes into contact with keratinous material in order to apply the composition thereto. The composition may be a cosmetic or a care product, e.g. a mascara, a foundation, a liquid lipstick, or a lip gloss. Where appropriate, the spring may surround a block of composition, the block of composition being a stick deodorant, for example. The composition may be a cleansing composition, a sunscreen, or a composition for application to the hair.

By way of example, when the spring surrounds a block of composition, the spring may project beyond the block while not in use and it may retract on coming into contact with the skin or the lips, in order to enable the distal end of the block to come into contact with the keratinous material. The spring may also have a distal end that is interposed between the keratinous material and the block of composition, even when the spring is in the retracted state, for example it may have a spiral-wound distal end for forming the distal face of the spring, at least in part.

The invention also provides a method of applying a cosmetic composition on human keratinous material, e.g. the skin, wherein an applicator member is brought into contact with said keratinous material, the applicator member comprising a spring and being loaded in composition. The applicator member may be subjected to vibration, e.g. when it is in contact with the keratinous material. The vibration may take place throughout the stage in which the applicator member is in contact with the keratinous material, or it may take place intermittently. By way of example, while the applicator member is in use, the only movement of the turns relative to one another may be due to the vibration generated by

the vibration source. The spring may vibrate at its resonant frequency.

In other exemplary embodiments, independently of the presence or absence of a vibration source, the invention
5 also provides an applicator for applying a cosmetic composition on human keratinous material, the applicator including an applicator member including a spring having at least a region thereof for coming into contact with the keratinous material, the spring defining a handle
10 surface of the device during application. The spring may have touching turns in a fraction defining the handle surface. This fraction may define an outwardly-open annular groove, for receiving two fingers of the hand holding the device.

In other exemplary embodiments, independently of the presence or absence of a vibration source, the invention
15 also provides an applicator for applying a cosmetic composition on human keratinous material, the applicator including an applicator member including a spring having at least a region thereof for coming into contact with the keratinous material, the spring including over at
20 least a fraction of its length an alternation of turns of outside diameter respectively greater than and less than an intermediate value. Such a spring may form grooves enabling the eyelashes to be combed, and it may
25 optionally surround a brush or a core of thermoplastic material carrying projecting elements.

In other exemplary embodiments, independently of the presence or absence of a vibration source, the invention
30 also provides an applicator for applying a cosmetic composition on human keratinous material, the applicator including an applicator member including a spring having at least a region thereof for coming into contact with the keratinous material, the spring being mounted to
35 rotate on the support. By way of example, the spring is mounted to rotate on a stem or on a device including a reservoir containing the composition for application.

In other exemplary embodiments, independently of the presence or absence of a vibration source, the invention also provides an applicator for applying a cosmetic composition on human keratinous material, the applicator including an applicator member including a spring having at least a region thereof for coming into contact with the keratinous material, the spring presenting an envelope surface that is rounded towards a distal end of the applicator member. The spring may have turns that are close together. The device may be used with the axis of the spring extending perpendicularly to the skin. The spring may optionally surround a block of composition.

In other exemplary embodiments, independently of the presence or absence of a vibration source, the invention also provides an applicator for applying a cosmetic composition on human keratinous material, the applicator including an applicator member including a spring having at least a region thereof for coming into contact with the keratinous material, the spring being mounted on a fastener skirt that is connected to a handle portion of the applicator. Such an applicator may be suitable, more particularly, for application on the skin, and, for example, it may be used with the longitudinal axis of the spring extending perpendicularly to the skin.

In other exemplary embodiments, independently of the presence or absence of a vibration source, the invention also provides an applicator for applying a cosmetic composition on human keratinous material, the applicator including an applicator member including a spring having at least a region thereof for coming into contact with the keratinous material, the spring having turns that are not circular, e.g. elliptical or polygonal, in particular square or triangular.

In other exemplary embodiments, independently of the presence or absence of a vibration source, the invention also provides an applicator for applying a cosmetic composition on human keratinous material, the applicator

including an applicator member including a spring having at least a region thereof for coming into contact with the keratinous material, the spring being mounted on a neck of a container containing the composition for application.

In other exemplary embodiments, independently of the presence or absence of a vibration source, the invention also provides an applicator for applying a cosmetic composition on human keratinous material, the applicator including an applicator member including a spring having at least a region thereof for coming into contact with the keratinous material, the applicator member including a second spring that is engaged at least in part inside the first spring. By way of example, the second spring may contribute to application and/or may improve the mechanical behavior of the first spring.

In other exemplary embodiments, independently of the presence or absence of a vibration source, the invention also provides a device for applying a cosmetic composition on human keratinous material, the device including a reservoir containing the composition for application, an applicator member including a spring having at least a region thereof for coming into contact with the keratinous material, and a housing receiving the spring while the device is not in use, said housing being separated from the reservoir by a wall that is permeable to the composition. The spring may replace the foam applicator members of known devices and it may provide novel sensations during application, and it may also facilitate cleaning.

In other exemplary embodiments, independently of the presence or absence of a vibration source, the invention also provides a device for applying a cosmetic composition on human keratinous material, the device including a reservoir containing the composition for application, the applicator including an applicator member including a spring having at least a region

thereof for coming into contact with the keratinous material, the spring surrounding a block of composition, at least in part.

5 In other exemplary embodiments, independently of the presence or absence of a vibration source, the invention also provides a device for applying a cosmetic composition on human keratinous material, the device including a reservoir containing the composition for application, the applicator including an applicator
10 member including a spring having at least a region thereof for coming into contact with the keratinous material, the spring surrounding a foam, at least in part.

15 These various aspects of the invention that are independent of the presence or absence of a vibration source may include any of the embodiment features described above.

The invention can be better understood on reading the following detailed description of non-limiting
20 embodiments thereof, and on examining the accompanying drawings, in which:

• Figure 1 is an elevation view, partially in longitudinal section, showing an embodiment of a packaging and applicator device made in accordance with
25 the invention;

• Figures 2A to 2C show various possibilities, amongst others for fastening the applicator element to the stem of the applicator;

• Figures 3A to 3F show various shapes, amongst
30 others, for springs that are to come into contact with keratinous material;

• Figures 4A to 4G show various section shapes, amongst others, of wires suitable for use in making the spring;

35 • Figures 5A to 5C show various shapes, amongst others, for turns;

• Figures 6A to 6D show various examples of applicator members in which the spring surrounds a core or another spring;

5 • Figures 7A and 7B show examples of vibration sources;

• Figure 8 shows a detail of the coupling between the vibration source and the applicator;

10 • Figures 9A, 9B, 10A, 10B, 11, 13 to 21, and 23 to 24 show other examples of applicator devices made in accordance with the invention;

• Figure 12 is an end view of the Figure 11 applicator; and

15 • Figure 22 is a section on XXII-XXII of the Figure 21 device, after the component elements of the container have been assembled together.

All of the devices shown in the figures and described below include a vibration source for exposing the applicator member to vibration.

20 As mentioned above, certain aspects of the invention are independent of the presence of such a vibration source, and the following description also applies to those other aspects, with the characteristics of the examples then being reproduced with the exception of the vibration source.

25

Vibration source

30 The vibration source is configured to generate vibration, e.g. sinusoidal vibration, e.g. at a frequency lying in the range 0.5 hertz (Hz) to 1000 Hz, or in the range 1 Hz to 500 Hz, better in the range 10 Hz to 300 Hz, e.g. in the range 50 Hz to 200 Hz.

35 The frequency may vary as a function of the location or the pressure with which the vibration is transmitted. The vibration may be produced intermittently or continuously. Its frequency may be selected as a function of the stiffness of the spring, so as to enable the spring to enter into resonance.

The vibration source may comprise a vibration generator having a motor, e.g. a motor in the form of a disk, that drives a flyweight in rotation, in particular an eccentric flyweight. The speed of rotation of the motor may lie in the range 2000 revolutions per minute (rpm) to 15,000 rpm, e.g. lying in the range 4500 rpm to 10,000 rpm.

The vibration generator may be of some other kind, e.g. piezoelectric, electromechanical, or having an eccentric. The vibration generator may also include a motor that rotates a toothed wheel in contact with a rattle comprising an elastically deformable blade.

The power supply voltage used may lie in the range 1.5 volts (V) to 9 V, for example. The vibration source may include an electricity source such as a 1.5 V button cell.

The use of a button cell may be found to be advantageous in order to reduce the size of the device. When using a button cell and a motor that is disk-shaped, the cell and the motor may be arranged face to face, side to side, or the face of one may face the edge of the other.

The vibration source may include a member for controlling its operation. This control member may be operated by being depressed. The control member may be placed in such a manner that it becomes depressed when the user takes hold of the device, in particular the container or the applicator. The control member may have a momentary contact, with the operation of the vibration source ceasing as soon as the control member is released.

The device may be configured to enable the vibration source to be actuated automatically when it is in place on the remainder of the device. In a variant, the vibration source may be actuated by the user acting on a contactor when the source is in place.

The vibration produced may be oriented substantially parallel to the longitudinal axis of the device and/or

parallel to the longitudinal axis of the applicator and/or parallel to the longitudinal axis of the applicator member.

In a variant, the vibration may be oriented
5 substantially perpendicularly to the longitudinal axis of the device and/or perpendicularly to the longitudinal axis of the applicator and/or perpendicularly to the longitudinal axis of the applicator member.

Where appropriate, the orientation of the vibration
10 may be modified by changing the position of the vibration source. The orientation of the motor relative to the applicator member may be modified when the vibration source is moved.

The vibration source may optionally be removable.
15

Devices

Figure 1 shows a first example of a packaging and applicator device 1 made in accordance with the invention. The packaging and applicator device 1
20 comprises a container 2 containing a composition P for application, together with an applicator 3 that is separable from the container 2, the applicator comprising a stem 4 fitted at its distal end with an applicator member 5 of longitudinal axis X, and being connected at
25 its proximal end to a handle member 6 also constituting a closure cap for the container 2. As shown, the closure cap 6 may be configured to cover an opening of the container.

The container 2 is fitted with a wiper member (not
30 shown), e.g. constituted by a piece of elastomer inserted in a neck of the container. The wiper member may be conventional or otherwise, or it may be adjustable. The handle member 6 is arranged to close the container 2 in leaktight manner on being screwed onto the neck, as is
35 known per se.

As shown, the handle member 6 may define a housing for receiving a removable source of vibration 20 on the

applicator. In a variant, the handle member may include a vibration source that is not removable.

The vibration source 20 includes a control surface 21, e.g. defined by a contactor that is operated by being
5 depressed.

On its side, starting from its proximal end, the handle member 6 presents a window 9 serving to pass a lever 41 that defines the control surface 21.

As shown in Figures 7A, 7B, and 8, the case 43 of
10 the vibration source 20 may include a finger 25 or any other projection suitable for conveying vibration from the vibration source 20 to the applicator member 5.

The finger 25 may come into contact with the handle member 6 in the bottom of the housing receiving the
15 vibration source 20, in order to transmit vibration to the applicator member, as shown in Figure 8.

As can be seen in Figure 7A, the case 43 of the vibration source 20 may be made using two half-shells 51 and 52 that are connected together by a film hinge 54 or
20 that are assembled together in some other way, for example the two half-shells 51 and 52 may be molded as a single piece of a thermoplastic material, or in a variant of some other material, e.g. a metal, providing care is taken to ensure that the case does not give rise to short
25 circuits.

By way of example, the half-shell 51 carries the finger 25 while the other half-shell presents a semi-circular opening 56 adapted to engage on the finger 25 when the case is closed. Assembly studs 60, e.g. two
30 such studs, are made on one of the half-shells, e.g. the half-shell carrying the lever 41, and are suitable for engaging in corresponding housings 62 in the other half-shell, situated on the other side of the hinge 54, for the purpose of holding the case 43 in the closed
35 position.

In the example shown, the lever 41 is integrally molded with the half-shell 52.

When the case 43 is closed, the user may press on the control surface 21 to close the electric circuit connecting a battery 80 to a motor 70, thereby switching on the motor. The motor 70 rotates a flyweight having
5 its center of inertia located off the axis of rotation.

The flyweight may be situated inside the casing of the motor 70, as in the example of Figure 7A, or it may be external to the motor, as in the example of Figure 7B, where it carries the reference 71.

10 The oscillation produced by the applicator member 5 may enhance the organization and/or the attachment of the composition applied to the skin or the eyelashes or to other keratinous material, e.g. hair, or it may clean them when the composition performs a cleansing action,
15 e.g. generating a foam.

When the device includes the vibration source 20 shown in Figure 7A, the vibration generated by the vibration source 20 is oriented longitudinally. The vibration source shown in Figure 7B generates vibration
20 that is oriented transversely to the longitudinal axis of the vibration source.

The frequency of the oscillation, its orientation, and its amplitude may be adapted to each type of application, depending on the looked-for result, e.g.
25 modifying the rheology of the composition and/or improving the deposition of the composition, or more generally improving the resulting makeup.

The vibration source may be made available to the user already mounted already on the container or the applicator, within packaging that may be constituted, for
30 example, by a presentation box, a sachet, a blister, or a carton. In a variant, the vibration source need not be assembled with the applicator or the container within the packaging. The vibration source may be made available
35 with at least two different containers or at least two different applicator members, within a single package.

In certain exemplary embodiments of the invention, the applicator member 5 includes a spring 100 that may be made in numerous ways, as described below.

By way of example, the spring 100 is fastened to the stem 4 by means of turns 101 that are placed around a portion 4a of the stem, as shown in Figure 2A.

The portion 4a may be of section that is smaller than the section of the major portion of the stem, such that the turns 101 are radially set back from the portion of the stem that is situated immediately above the portion 4a.

The spring 100 may also be inserted in a housing 4b of the stem 4, which housing may include a narrow portion 4c as shown in Figure 2B, the narrow portion being formed by stamping the stem 4 after the spring 100 has been put into place, for example.

The spring 100 may include a rectilinear end 100f that is inserted in a housing 4b formed in the end of the stem 4, as shown in Figure 2C.

The stem 4 may optionally be molded onto the end 100f.

The spring may also be fastened in other ways to the stem 4, e.g. by adhesive bonding with the stem 4, heat-sealing or overmolding the stem on the spring, or by snap-fastening the stem in the spring, or vice versa.

The spring may optionally be molded integrally with the stem, or it may be formed by deforming a distal portion of the stem.

The variants shown in Figures 2A to 2C do not exclude additional fastening of the spring to the stem being provided by adhesive and/or heat-sealing.

The invention is not limited to the shapes of spring 100 shown in part in Figures 2A to 2C, and the particular fastening mentioned above apply likewise to fastening any type of spring of the invention to any type of support.

The spring 100 may be given the various shapes shown in figures 3A to 3F, which shapes are not limiting. In

these Figures, there can be seen the envelope surface E of the spring. It can be seen that the envelope surface E may have a portion generally in the form of a cylindrical surface of revolution, as shown in Figure 3A.

5 The spring 100 may also present an envelope surface E that is generally in the form of a surface of revolution, e.g. in the form of a ball, as shown in Figure 3B, e.g. a spherical ball.

The envelope surface E may also be made
10 eccentrically relative to the longitudinal axis Z of the distal portion of the stem or other support of the device carrying the spring 100, as shown in Figure 3C.

Figure 3D shows that the envelope surface E may pass through an extremum between the proximal and distal ends
15 of the spring 100, e.g. through a minimum at as shown.

Figure 3E shows the possibility of the spring 100 presenting pitch between adjacent turns that varies as a function of position along the longitudinal axis of the spring. For example, the spring presents a pitch p_i
20 between adjacent turns close to its distal end that is smaller than its pitch p_j in a middle region of the spring.

The pitch between turns may decrease going towards the support carrying the spring, e.g. the stem 4 as
25 shown. By way of example, the portion of the spring in contact with the stem has turns that are close together or even touching.

Figure 3F shows that the spring 100 may have alternating turns of respective diameters that are less
30 than and greater than an intermediate radius R_i so as to form a succession of grooves that may be useful for combing the eyelashes.

All of the springs shown in Figures 3A to 3F are shown in part and without any flocking, but it would not
35 go beyond the ambit of the present invention for the springs to be flocked, either completely or in part.

Figures 4A to 4G show various different wires suitable for use in making the spring.

By way of example, it is possible to use a wire of circular section, as shown in Figure 4A, or of section that is polygonal, in particular triangular as shown in Figure 4B, or square as shown in Figure 4C. The wire may also present a section that is flat, in particular rectangular, as shown in Figure 4D, or oval as shown in Figure 4E.

The diameter of the wire (i.e. its greatest transverse dimension) may lie in the range one-tenth of a millimeter (mm) to 3 mm, for example.

Sections of other shapes are also possible, and it is possible to use two or more wires extending side by side to form the spring.

The wire used for making the spring may carry flocking as shown in Figure 4F, with it being possible for the spring to be flocked after it has been fabricated.

The flocking may have a variety of bristles, e.g. of length up to as much as 2 mm.

It is possible to use a mixture of types of flocking.

The spring may be made with a sheathed wire, as shown in Figure 4G. By way of example, the sheath may be a coating of thermoplastic material, of paint, or of varnish. The sheath may provide protection against corrosion and/or improve sliding. The bristles of the flocking may be secured to the filament of the spring, which need not necessarily be a wire made of metal, by means of an adhesive sheathing the filament.

The spring may present turns of different shapes, e.g. circular as shown in Figure 5A, and of diameter that may be constant or otherwise. The turns may be non-circular, e.g. polygonal, in particular generally square as shown in Figure 5B, or oval, e.g. generally elliptical, as shown in Figure 5C.

The spring 100 may optionally surround a core, over at least a fraction of its length.

Figure 6A shows the possibility for the spring 100 to surround the core 120 of a "twisted-core" brush. In this example, the core comprises two branches of a metal wire that are twisted together around bristles 125, in known manner. A portion of the core 120 that does not have bristles is received, for example, in a housing 4e of the stem 4, this housing being defined by a tubular wall 4f of the stem 4, for example. The spring 100 has turns that surround the wall 4f. The wall 4f may be radially set back from the outside surface 4g of the stem 4, as shown in Figure 6A.

The spring 100 may also surround a core 140 made of thermoplastic material, e.g. integrally molded with the stem 4. As shown in Figure 6B, the core 140 may carry projecting elements 145, e.g. elements in the form of teeth, which elements may extend in numbers of one, two, or more between adjacent turns of the spring. These projecting elements may project beyond the envelope surface of the spring 100, e.g. contributing to combing the eyelashes. These projecting elements may be placed on the core in such a manner as to enable the spring to be engaged thereon by screwing the spring onto the core.

As shown in Figure 6C, the spring 100 may also surround a second spring 150, over at least a fraction of its length. The second spring 150 may for example be carried by a narrower portion 4i of the stem 4, adjacent to the distal end thereof.

In particular when the spring 100 surrounds a core, the core may extend beyond the distal end 103 of the spring, as shown in Figure 6D. In this figure, the core 140, e.g. made of thermoplastic material molded integrally with the stem 4, presents a head 148 at its distal end, which head is suitable for holding the spring 100 axially to the stem. Where appropriate, the spring

100 may be compressed axially between a shoulder 149 of the stem 4 and the head 148.

Figure 9A shows the possibility for the spring 100 to form part of an applicator 3 that is configured to
5 apply a composition on a surface such as the skin. The spring 100 is mounted on a tubular skirt 160 of the applicator 3 and defines an envelope surface E that is of generally rounded shape, being outwardly convex. In the variant Figure 9B, the envelope surface E also presents
10 an outwardly-concave portion. The applicator 3 may present a housing beside its proximal end suitable for receiving a vibration source 20. When not in use, the spring 100 may be received in a housing 170 of the device, this housing communicating with a reservoir 171
15 containing the composition for application. A wall 173 separates the housing 170 from the reservoir 171. In the example described, this wall is pierced by one or more orifices 174 enabling the applicator member constituted by the spring 100 to be fed with composition. When the
20 applicator is in place in the housing 170, the spring may optionally be compressed.

In the embodiment of Figure 10A, the distal end of the spring 100 comes to bear against a surface 200 loaded with composition for application. By way of example,
25 this surface is defined by the top face of a block of composition P.

The spring 100 may be carried by a tubular skirt 210 forming a portion of an applicator 3 that is capable of being separated from the container containing the block
30 of composition.

The spring 100 may also surround a foam 110 as shown in Figure 10B. The foam 110, as illustrated, is not in contact with the spring 100. In another embodiment, not illustrated, when inside the closed container the foam is
35 in contact with the spring 100.

When the applicator 3 is not in use and not on the container, the foam may optionally be in contact with the spring.

5 Optionally, the foam 110 may be supported by a housing 215 inside the tubular skirt 210.

10 The spring 100 may be compressed inside the container so as to remain in contact with the surface 200 as the block of composition is used up. When the spring 100 surrounds a foam, the foam may also be compressed inside the container so as to remain in contact with the surface 200 of the product in other embodiments the foam may not be in contact with the surface of the product.

15 When the spring 100 surrounds a foam, the foam in the container may not touch the spring as shown, or in another embodiment it may touch the spring. Optionally, the foam in the container may be in contact with the product.

20 Figure 10B shows a spring 100 that is configured to apply a composition on a surface such as the skin. Other applicators, such as those disclosed at Figures 1, 3A-3F, for example, may also comprise a spring surrounding a foam. Figure 11 shows a variant in which the composition is delivered into the housing receiving the spring 100 by means of a valve or pump stem 218. The applicator may be moved relative to the container 2 containing the composition in order to actuate the stem 218.

30 The spring 100 may present a front face 103, defined by a spiral winding of the spring wire, with optionally touching turns, as shown in Figure 12.

Figure 13 shows an applicator in which the spring 100 extends around the composition P, which composition is in the form of a stick, by way of example.

35 The distal end of the stick of composition may be situated between the proximal and distal ends of the spring 100. The composition is thus dispensed through

the spring 100 when the applicator is brought into contact with keratinous material. In a variant, the distal end of the applicator is defined by the distal end of the stick, the turns being of inside diameter that is greater than the diameter of the stick, at least over a fraction of the spring extending from its distal end towards its proximal end.

Figure 14 shows a variant embodiment in which, during application of the composition, the applicator member 5 including the spring 100 is secured to the container that contains the composition. By way of example, the spring 100 is mounted on a neck of the container. The composition may be dispensed through the spring, e.g. between the turns and/or through the turn at the distal end.

In Figure 15, the applicator 3 is received in a housing 220 made in a protective capsule suitable for mounting on a container 2. By way of example, the container is a bottle provided with a pump.

The device shown in Figure 16 includes an applicator 300 and a finishing device having a spring 100 and a vibration source 20 for subjecting the spring 100 to vibration while it is in use.

The finishing device 100 may be used independently of the applicator 300.

The applicator 3 including the spring 100 and the vibration source may be received in a case having one or more supplies of one or more compositions P for application, e.g. in the form of a free or compacted powder or a block cast in a cup, as shown in Figure 17.

Figure 18 shows the possibility of the spring 100 defining a handle surface of the applicator 3. The spring 100 may surround the vibration source 20, at least in part. The source may include a contactor with a permanent contact, such that after action has been taken on the control surface 21, the vibration source remains in the same state of operation until the next time action

is taken on said surface. The vibration source 20 may be removably inserted inside the turns of the spring 100, from its proximal end.

5 The spring 100 may be placed between the tines 330 of a fork, as shown in Figure 19. The spring 100 may optionally be rotatable. By way of example, the spring 100 turns about an axis of rotation K, which axis may be perpendicular to the longitudinal axis of the device.

10 Figure 20, shows the possibility of the device including a plurality of springs 100, e.g. mounted to rotate about respective axes K_1 and K_2 , which axes are at an angle relative to each other. The device may include a housing 333 for receiving the vibration source. The handle surface may be defined by the body of a container
15 2 containing the composition for application. As shown, the composition may be dispensed via a dispenser orifice situated at the end opposite from the springs 100. This orifice may be closed by a closure cap 335. The turns of the springs 100 may touch one another at the ends of the
20 springs so as to hold the springs on two respective shafts around which they rotate, or on shafts that are rotatably mounted on the device.

In Figures 21 and 22, there can be seen the possibility of the container being made in accordance
25 with the teaching of European patent EP 1 584 260.

The container may comprise two portions 2a and 2b suitable for turning relative to each other. One of the portions has a blade 2c and the other a backing-blade 2d, such that turning the two portions causes the composition
30 to move within the container 2. The applicator member 5 may be situated at the center of the container on the path of the composition flowing from one of the two chambers formed between the blade and the backing-blade towards the other chamber, while one portion is being
35 turned relative to the other.

Figures 23 and 24 show the possibility of the spring to be fastened on a support 230. In Figure 23, the

support is overmolded on the first turns of the spring, which are touching. In Figure 24, the spring is fastened in the skirt. The support 230 is fastened in the neck of the container 2 by snap-fastening. The support may be
5 fastened by any means known from the skilled in the art (e.g. screw fastening, force-fitting, adhesive, heat sealing).

The expression "comprising a" should be understood as being synonymous with "comprising at least one" unless
10 specified to the contrary.

CLAIMS

1. A device for applying a cosmetic on human keratinous material and/or for finishing off the application of makeup and/or for massaging, the device comprising:
- 5 • a vibration source (20); and
- an applicator member exposed to the vibration of the vibration source, the member including a spring (100) having at least a region thereof for coming into contact with said keratinous material.
- 10
2. A device according to claim 1, the spring (100) being free at one end.
3. A device according to claim 1 or claim 2, including a
- 15 core (120; 140) extending longitudinally inside the spring (100).
4. A device according to claim 3, the core carrying one or more projecting elements (125; 145).
- 20
5. A device according to claim 4, the projecting elements carried by the core extending between the turns of the spring (100) and projecting outside the spring.
- 25
6. A device according to any one of claims 1 to 5, the turns being of varying diameter.
7. A device according to any one of claims 1 to 6, the spring (100) being flocked, at least in part.
- 30
8. A device according to any one of claims 1 to 7, the pitch between the turns of the spring being at a maximum at a distance from the proximal and distal ends of the spring.
- 35

9. A device according to any one of claims 1 to 8, the front end of the spring being closed by winding at least one wire of the spring.
- 5 10. A device according to any one of claims 1 to 9, at least a fraction of the length of the spring surrounding a brush.
- 10 11. A device according to any one of claims 1 to 10, the device including a housing for receiving the applicator member when not in use, the applicator member being in the compressed state when received in the housing.
- 15 12. A device according to any one of claims 1 to 11, the applicator member being received in a housing, when not in use, and bearing at one end against a surface (200) that is loaded in composition, in particular a surface loaded in composition that is defined by a
20 face of a block of said composition.
13. A device according to any one of claims 1 to 12, the spring defining a handle surface of the device during
25 application.
14. A device according to any one of claims 1 to 13, the applicator member being mounted to rotate on a support.
- 30 15. A cosmetic treatment method in which keratinous material is brought into contact with an applicator member including a spring, forming part of a device as defined in any one of claims 1 to 14.

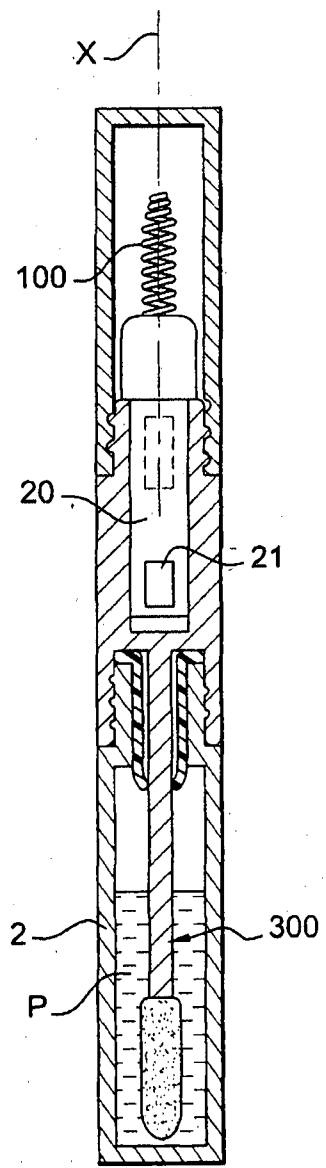
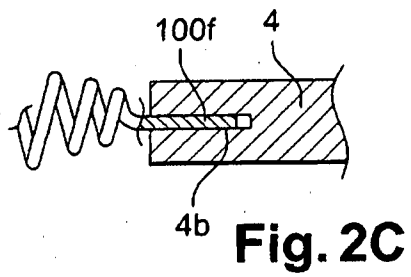
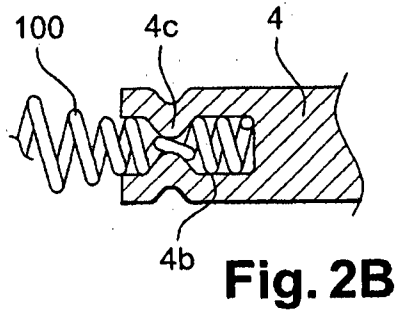
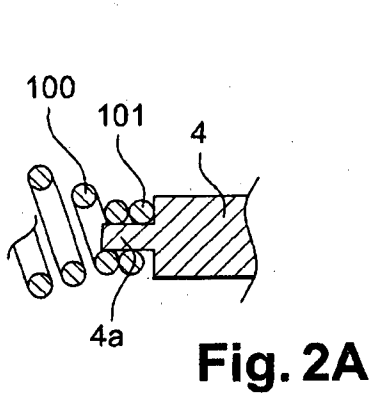
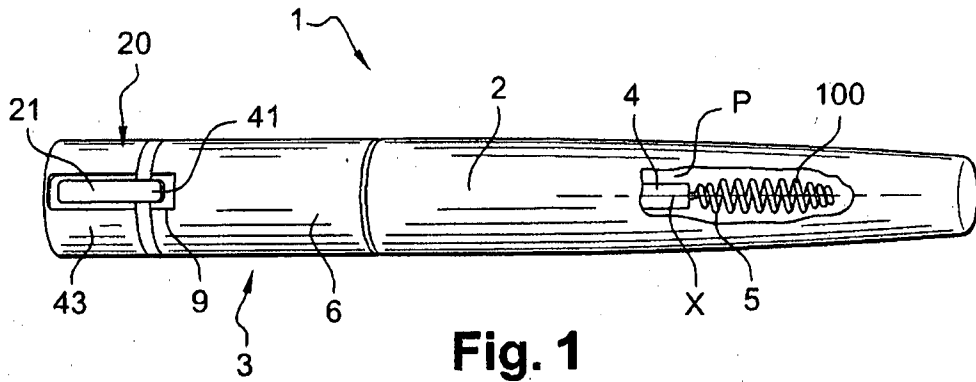

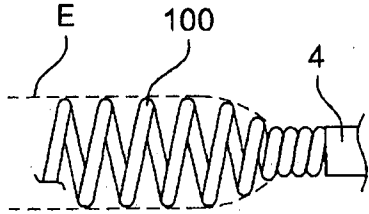

Fig. 3A

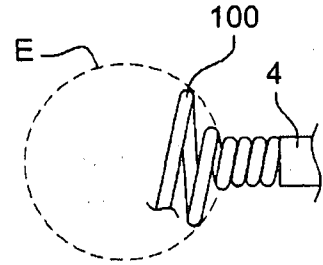

Fig. 3B

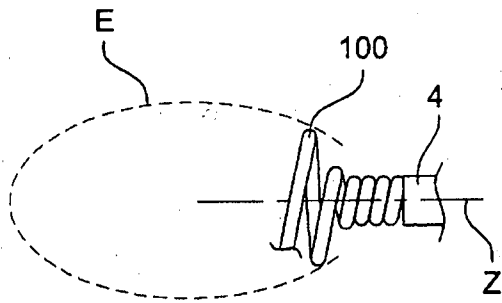

Fig. 3C

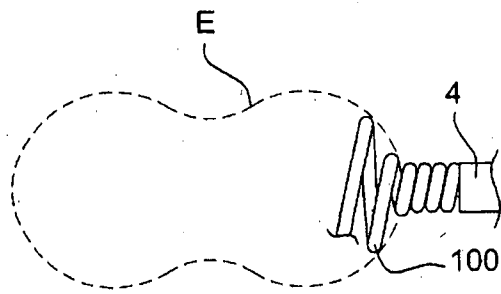

Fig. 3D

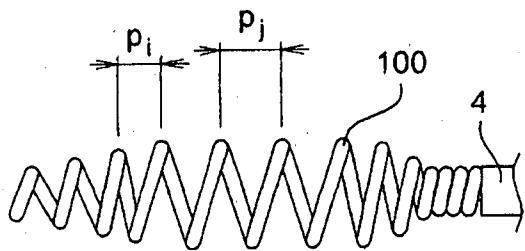

Fig. 3E

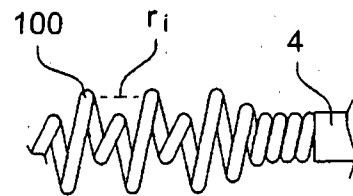

Fig. 3F



Fig. 4A



Fig. 4B



Fig. 4C

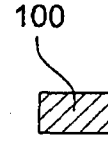

Fig. 4D

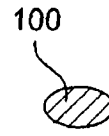

Fig. 4E

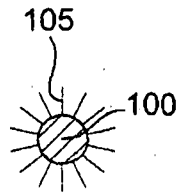

Fig. 4F

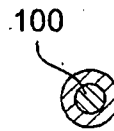

Fig. 4G

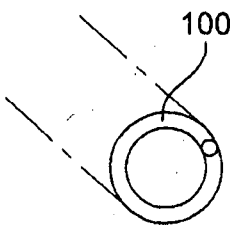

Fig. 5A

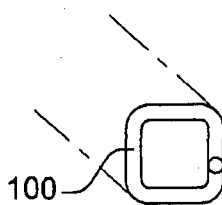

Fig. 5B

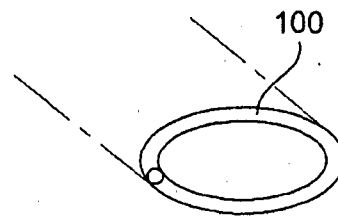

Fig. 5C

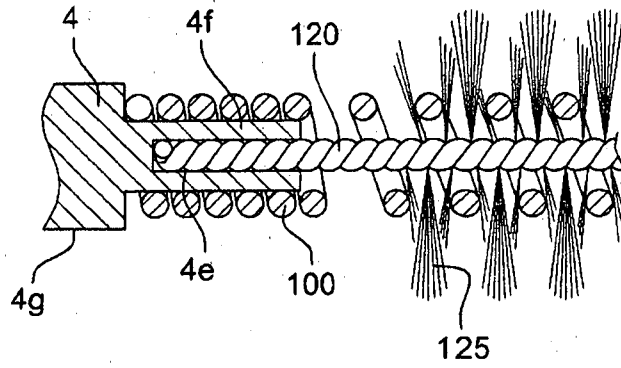

Fig. 6A

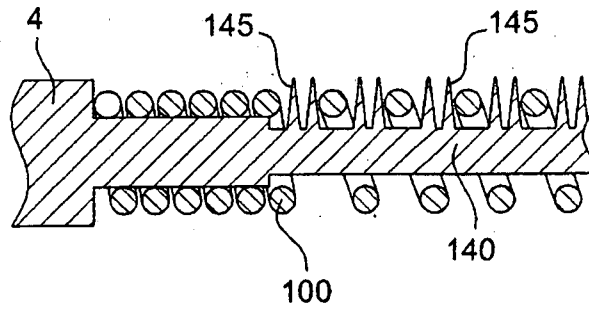

Fig. 6B

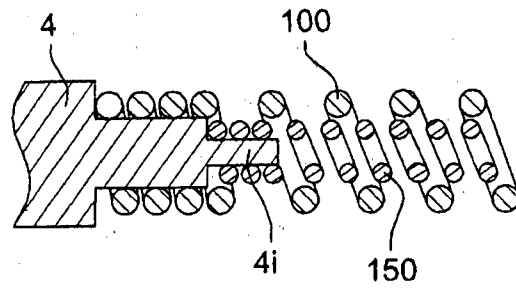

Fig. 6C

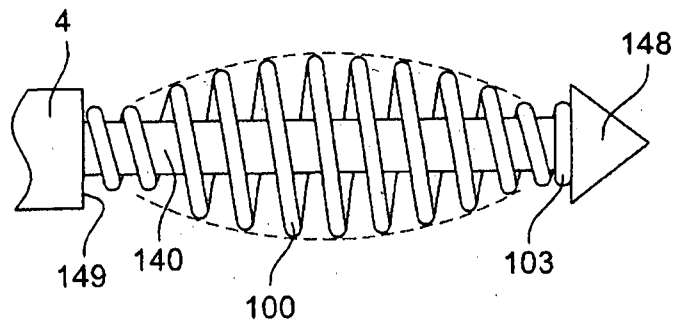

Fig. 6D

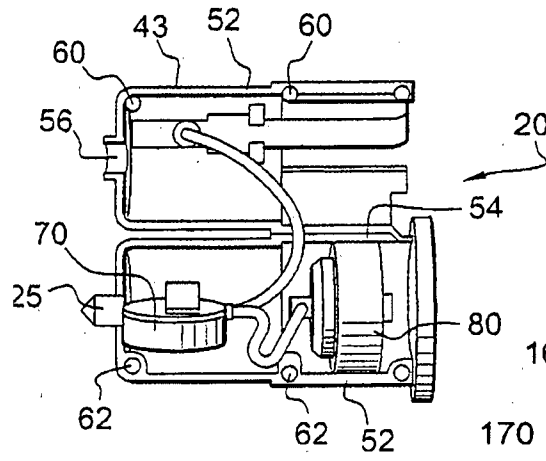

Fig. 7A

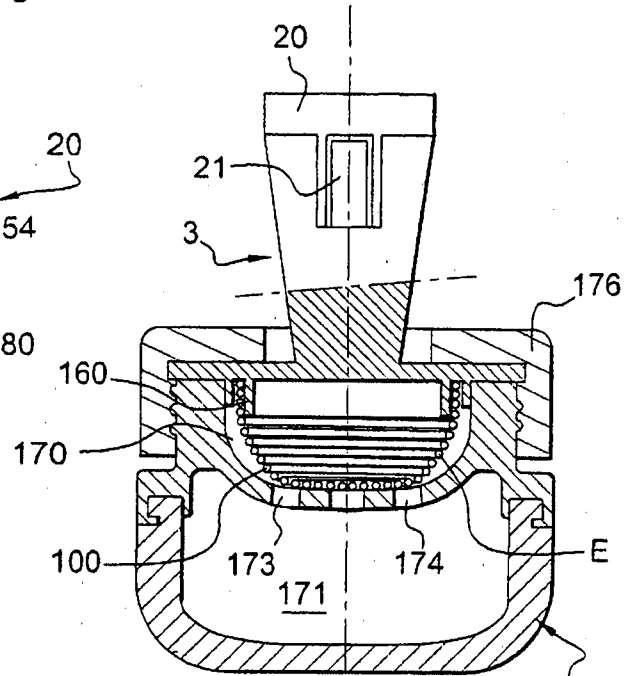

Fig. 9A

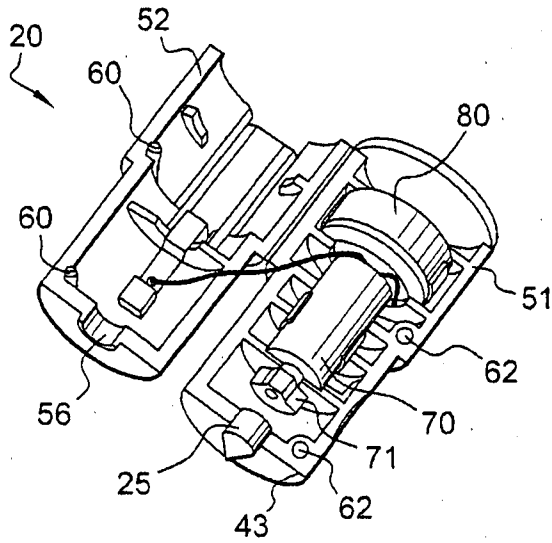

Fig. 7B

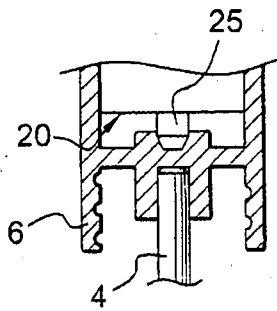

Fig. 8

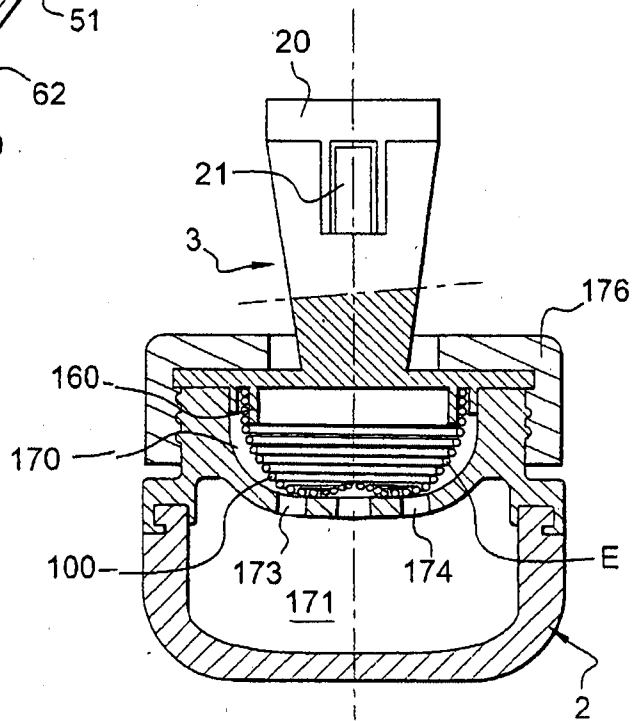

Fig. 9B

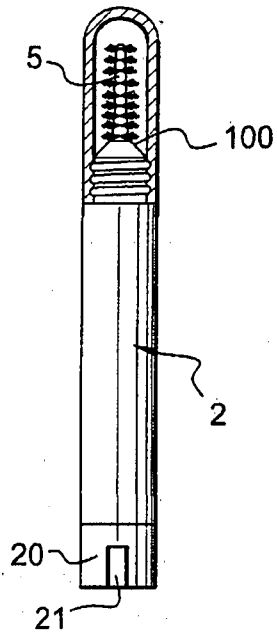

Fig. 14

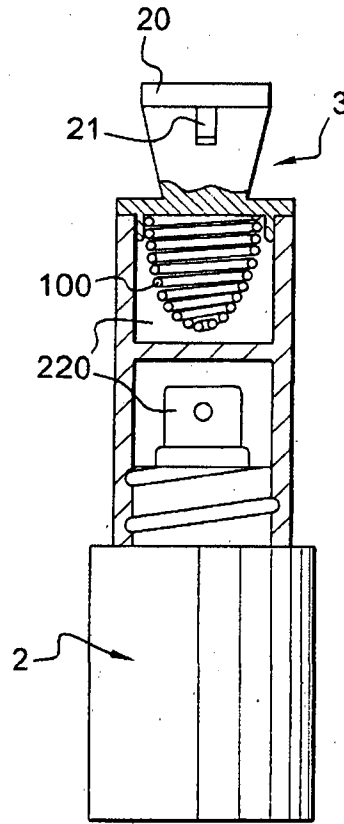

Fig. 15

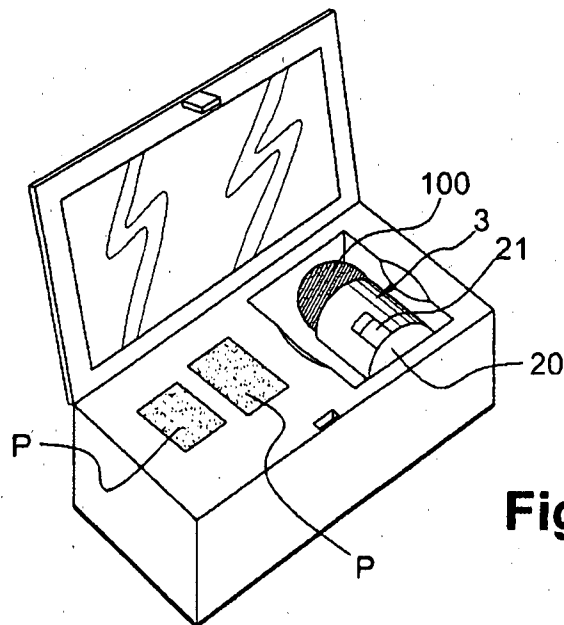

Fig. 17

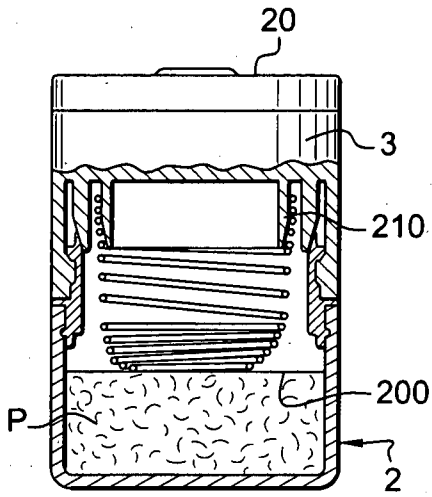

Fig. 10A

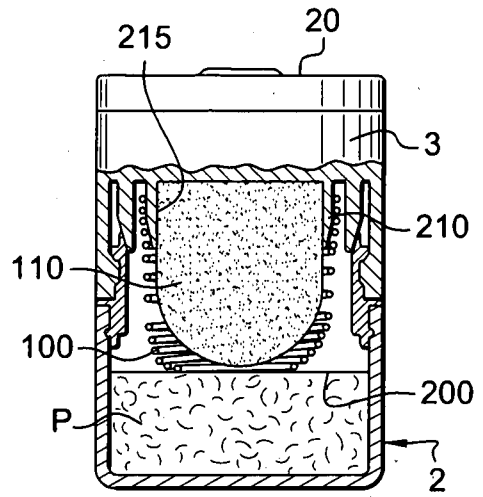

Fig. 10B

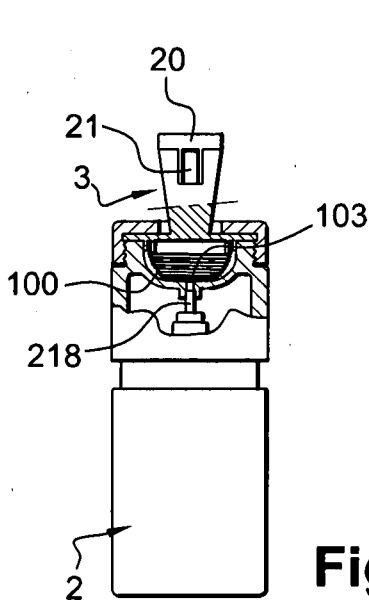

Fig. 11

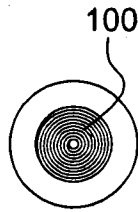

Fig. 12

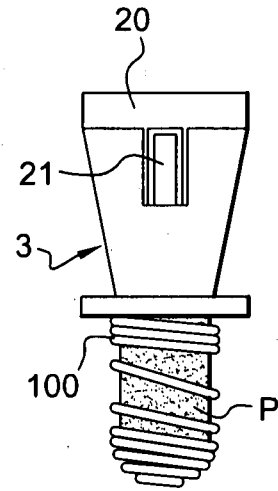

Fig. 13

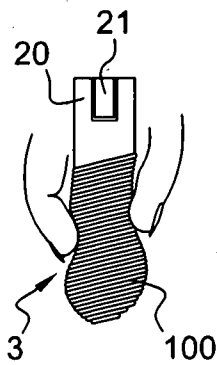

Fig. 18

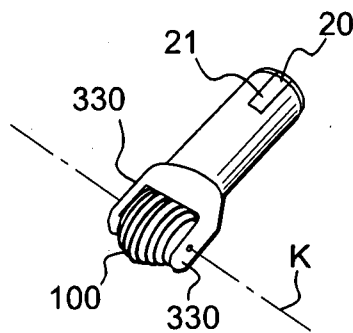

Fig. 19

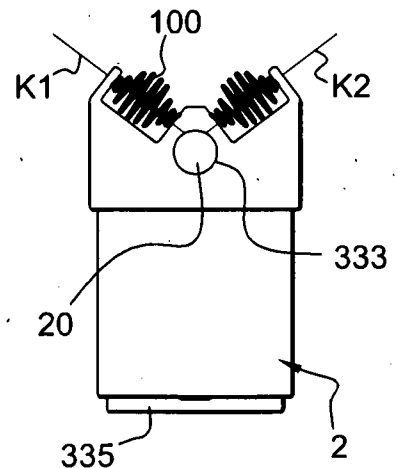

Fig. 20

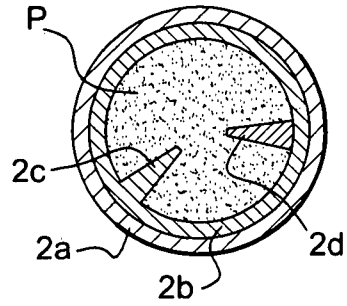
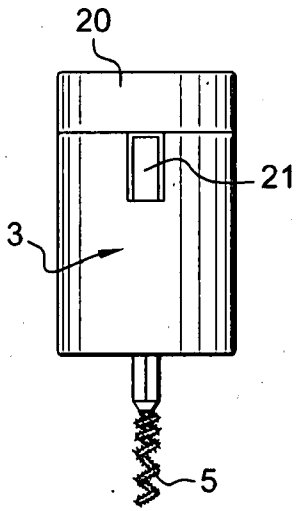

Fig. 22

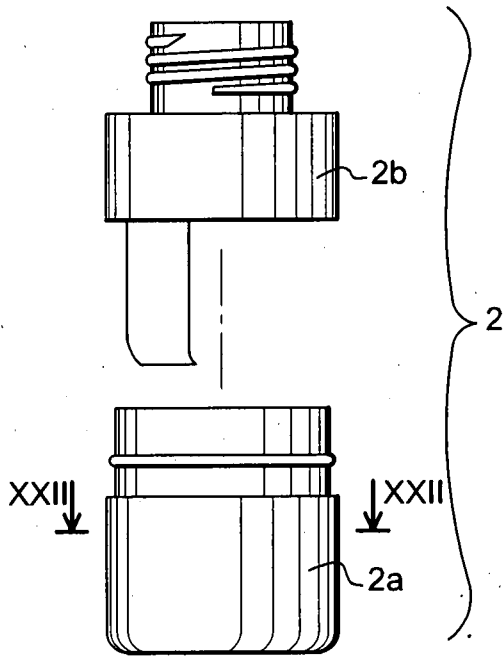

Fig. 21

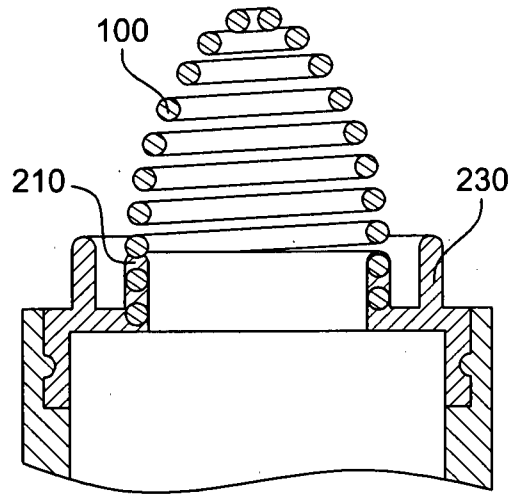

Fig. 23

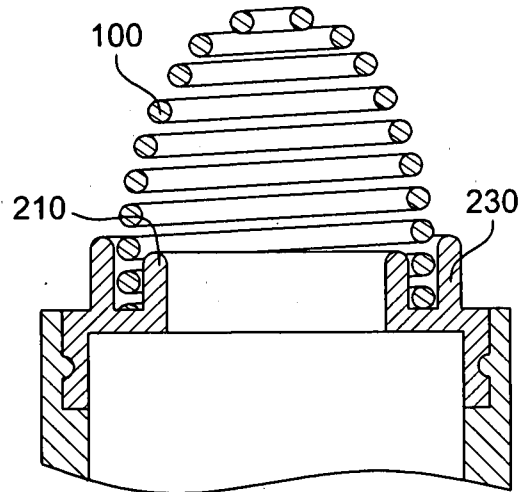

Fig. 24

INTERNATIONAL SEARCH REPORT

International application No
PCT/IB2010/050649

A. CLASSIFICATION OF SUBJECT MATTER
INV. A45D40/26
ADD.

According to International Patent Classification (IPC) or to both national classification and IPC

B. FIELDS SEARCHED

Minimum documentation searched (classification system followed by classification symbols)
A45D

Documentation searched other than minimum documentation to the extent that such documents are included in the fields searched

Electronic data base consulted during the international search (name of data base and, where practical, search terms used)

EPO-Internal

C. DOCUMENTS CONSIDERED TO BE RELEVANT

Category*	Citation of document, with indication, where appropriate, of the relevant passages	Relevant to claim No.
Y	US 4 744 377 A (DOLAN JR HOWARD D [US]) 17 May 1988 (1988-05-17) the whole document	1-7, 10-15
Y	WO 2006/130642 A1 (PROCTER & GAMBLE [US]; WYATT PETER JONATHAN [US]; WILSON DAVID EDWARD) 7 December 2006 (2006-12-07) the whole document	1-7, 10-15
A	US 2007/289602 A1 (SIMMONS JOAN LILLIAN [CA]) 20 December 2007 (2007-12-20) the whole document	1-15
A	GB 2 284 750 A (OREAL [FR]) 21 June 1995 (1995-06-21) the whole document	1-15
	-/--	

Further documents are listed in the continuation of Box C.

See patent family annex.

* Special categories of cited documents :

"A" document defining the general state of the art which is not considered to be of particular relevance

"E" earlier document but published on or after the international filing date

"L" document which may throw doubts on priority claim(s) or which is cited to establish the publication date of another citation or other special reason (as specified)

"O" document referring to an oral disclosure, use, exhibition or other means

"P" document published prior to the international filing date but later than the priority date claimed

"T" later document published after the international filing date or priority date and not in conflict with the application but cited to understand the principle or theory underlying the invention

"X" document of particular relevance; the claimed invention cannot be considered novel or cannot be considered to involve an inventive step when the document is taken alone

"Y" document of particular relevance; the claimed invention cannot be considered to involve an inventive step when the document is combined with one or more other such documents, such combination being obvious to a person skilled in the art.

"&" document member of the same patent family

Date of the actual completion of the international search

11 June 2010

Date of mailing of the international search report

24/06/2010

Name and mailing address of the ISA/

European Patent Office, P.B. 5818 Patentlaan 2
NL - 2280 HV Rijswijk
Tel. (+31-70) 340-2040,
Fax: (+31-70) 340-3016

Authorized officer

Nicolás, Carlos

INTERNATIONAL SEARCH REPORT

International application No
PCT/IB2010/050649

C(Continuation). DOCUMENTS CONSIDERED TO BE RELEVANT		
Category*	Citation of document, with indication, where appropriate, of the relevant passages	Relevant to claim No.
X,P	WO 2009/037609 A1 (PROCTER & GAMBLE [US]; WYATT PETER JONATHAN [US]; SANFORD RONALD ALAN) 26 March 2009 (2009-03-26) the whole document -----	1-4,6, 12,14,15

INTERNATIONAL SEARCH REPORT

Information on patent family members

International application No PCT/IB2010/050649

Patent document cited in search report	Publication date	Patent family member(s)	Publication date																																
US 4744377	A	17-05-1988	NONE																																
WO 2006130642	A1	07-12-2006	<table style="width: 100%; border-collapse: collapse;"> <tr> <td style="width: 15%;">AU</td> <td style="width: 15%;">2006252567</td> <td style="width: 15%;">A1</td> <td style="width: 55%;">07-12-2006</td> </tr> <tr> <td>CA</td> <td>2610718</td> <td>A1</td> <td>07-12-2006</td> </tr> <tr> <td>CN</td> <td>101188958</td> <td>A</td> <td>28-05-2008</td> </tr> <tr> <td>EP</td> <td>1898743</td> <td>A1</td> <td>19-03-2008</td> </tr> <tr> <td>JP</td> <td>2008541941</td> <td>T</td> <td>27-11-2008</td> </tr> <tr> <td>KR</td> <td>20080011419</td> <td>A</td> <td>04-02-2008</td> </tr> <tr> <td>US</td> <td>2006272668</td> <td>A1</td> <td>07-12-2006</td> </tr> <tr> <td>US</td> <td>2010000566</td> <td>A1</td> <td>07-01-2010</td> </tr> </table>	AU	2006252567	A1	07-12-2006	CA	2610718	A1	07-12-2006	CN	101188958	A	28-05-2008	EP	1898743	A1	19-03-2008	JP	2008541941	T	27-11-2008	KR	20080011419	A	04-02-2008	US	2006272668	A1	07-12-2006	US	2010000566	A1	07-01-2010
AU	2006252567	A1	07-12-2006																																
CA	2610718	A1	07-12-2006																																
CN	101188958	A	28-05-2008																																
EP	1898743	A1	19-03-2008																																
JP	2008541941	T	27-11-2008																																
KR	20080011419	A	04-02-2008																																
US	2006272668	A1	07-12-2006																																
US	2010000566	A1	07-01-2010																																
US 2007289602	A1	20-12-2007	NONE																																
GB 2284750	A	21-06-1995	<table style="width: 100%; border-collapse: collapse;"> <tr> <td style="width: 15%;">FR</td> <td style="width: 15%;">2713454</td> <td style="width: 15%;">A1</td> <td style="width: 55%;">16-06-1995</td> </tr> <tr> <td>US</td> <td>5575579</td> <td>A</td> <td>19-11-1996</td> </tr> </table>	FR	2713454	A1	16-06-1995	US	5575579	A	19-11-1996																								
FR	2713454	A1	16-06-1995																																
US	5575579	A	19-11-1996																																
WO 2009037609	A1	26-03-2009	<table style="width: 100%; border-collapse: collapse;"> <tr> <td style="width: 15%;">WO</td> <td style="width: 15%;">2009037608</td> <td style="width: 15%;">A2</td> <td style="width: 55%;">26-03-2009</td> </tr> <tr> <td>US</td> <td>2009071499</td> <td>A1</td> <td>19-03-2009</td> </tr> <tr> <td>US</td> <td>2009071500</td> <td>A1</td> <td>19-03-2009</td> </tr> </table>	WO	2009037608	A2	26-03-2009	US	2009071499	A1	19-03-2009	US	2009071500	A1	19-03-2009																				
WO	2009037608	A2	26-03-2009																																
US	2009071499	A1	19-03-2009																																
US	2009071500	A1	19-03-2009																																