



(51) International Patent Classification:

A61M 16/08 (2006.01) A61M 16/10 (2006.01)  
A61M 16/16 (2006.01) H05B 3/40 (2006.01)

(21) International Application Number:

PCT/IB2013/055439

(22) International Filing Date:

3 July 2013 (03.07.2013)

(25) Filing Language:

English

(26) Publication Language:

English

(30) Priority Data:

61/667,554 3 July 2012 (03.07.2012) US

(71) Applicant: **KONINKLIJKE PHILIPS N.V.** [NL/NL];  
High Tech Campus 5, NL-5656 AE Eindhoven (NL).

(72) Inventors: **ARCILLA, Mabini**; c/o High Tech Campus 5,  
NL-5656 AE Eindhoven (NL). **GARDE, Smita**; c/o High  
Tech Campus 5, NL-5656 AE Eindhoven (NL).

(74) Agents: **STEFFEN, Thomas** et al.; High Tech Campus  
Building 5, NL-5656 AE Eindhoven (NL).

(81) Designated States (unless otherwise indicated, for every  
kind of national protection available): AE, AG, AL, AM,  
AO, AT, AU, AZ, BA, BB, BG, BH, BN, BR, BW, BY,  
BZ, CA, CH, CL, CN, CO, CR, CU, CZ, DE, DK, DM,  
DO, DZ, EC, EE, EG, ES, FI, GB, GD, GE, GH, GM, GT,  
HN, HR, HU, ID, IL, IN, IS, JP, KE, KG, KN, KP, KR,

KZ, LA, LC, LK, LR, LS, LT, LU, LY, MA, MD, ME,  
MG, MK, MN, MW, MX, MY, MZ, NA, NG, NI, NO, NZ,  
OM, PA, PE, PG, PH, PL, PT, QA, RO, RS, RU, RW, SC,  
SD, SE, SG, SK, SL, SM, ST, SV, SY, TH, TJ, TM, TN,  
TR, TT, TZ, UA, UG, US, UZ, VC, VN, ZA, ZM, ZW.

(84) Designated States (unless otherwise indicated, for every  
kind of regional protection available): ARIPO (BW, GH,  
GM, KE, LR, LS, MW, MZ, NA, RW, SD, SL, SZ, TZ,  
UG, ZM, ZW), Eurasian (AM, AZ, BY, KG, KZ, RU, TJ,  
TM), European (AL, AT, BE, BG, CH, CY, CZ, DE, DK,  
EE, ES, FI, FR, GB, GR, HR, HU, IE, IS, IT, LT, LU, LV,  
MC, MK, MT, NL, NO, PL, PT, RO, RS, SE, SI, SK, SM,  
TR), OAPI (BF, BJ, CF, CG, CI, CM, GA, GN, GQ, GW,  
KM, ML, MR, NE, SN, TD, TG).

**Declarations under Rule 4.17:**

- as to applicant's entitlement to apply for and be granted a patent (Rule 4.17(ii))
- as to the applicant's entitlement to claim the priority of the earlier application (Rule 4.17(iii))

**Published:**

- with international search report (Art. 21(3))
- before the expiration of the time limit for amending the claims and to be republished in the event of receipt of amendments (Rule 48.2(h))

(54) Title: A COMPACT HUMIDIFIER

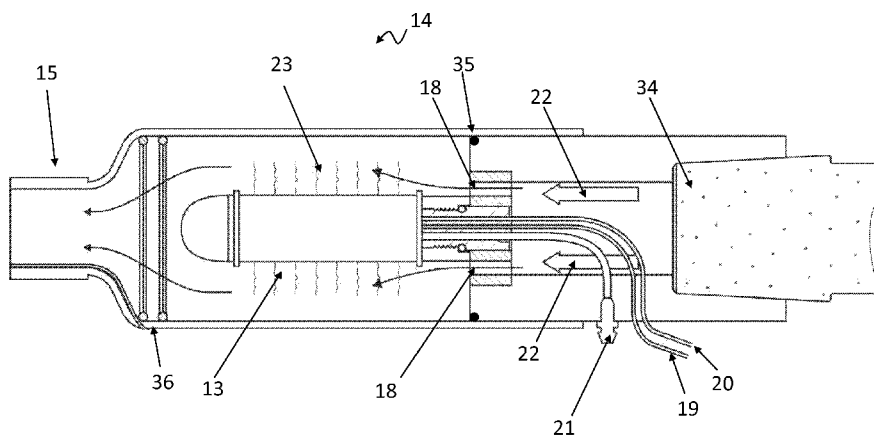

FIG. 3

(57) Abstract: The invention relates to a humidifier that can be integrated with a ventilator allowing it to continue humidification during patient transport. The humidifier can be placed at the ventilator outlet port and have a size that adds minimal resistance and compliance in the inspiratory arm of the patient circuit. The innermost core of the humidifier is the heater element that is positioned inside a hydrophobic membrane, allowing for humidification of the gas flowing around the hydrophobic membrane.

WO 2014/006574 A1

A compact humidifier

## FIELD OF THE INVENTION

The present invention relates to disposable active respiration humidifier for invasive or non-invasive ventilation of a patient.

## 5 BACKGROUND OF THE INVENTION

Respiration humidifiers are used to humidify the inspiratory gas of respirators to physiological levels.

The upper airway of a patient normally warms and humidifies the inspired gases during normal breathing. However, this is compromised when inspired gas is delivered  
10 by invasive or non-invasive ventilator. During invasive ventilation, the use of endotracheal tube bypasses the upper airway and so upper airways cannot contribute to heating and humidification of the delivered gases. This may lead to bronchial inflammation and related respiratory complications. . During non-invasive ventilation, the nasal mucosa may not be able to adequately warm and humidify the inspired gas and can lead to thick mucus leading to  
15 increase in airway resistance and reduced lung compliance.

Hence in clinical practice, humidifiers are used to provide adequate heat and humidification to the delivered gas.

Generally humidifiers are rather bulky, heavy and may be characterized by a high degree of heat loss.

20 Humidifiers, such as heat and moisture exchangers (HME), also referred to as passive humidifiers may not be able to reliably maintain the temperature and humidity for high flow of inspired gas as humidity is usually maintained by the exhaled air. In contrast, heated humidifiers (HH), also referred to as active humidifiers try to maintain the temperature and humidity of delivered gas by controlling a heating plate that heats and  
25 evaporates the water in path of gas flow. However, these humidifiers introduce additional dead space or additional resistance in the circuit, or may have to be changed daily as for HMEs to avoid bacterial contamination, or cannot reliably deliver heated and humidified gas.

Such devices, which operate according to various principles, are arranged, in general, separated from the respirator.

One drawback of the separate arrangement for the user is, among other things, the large number of different tubing and connections.

Another drawback of the current humidifiers is that, during the transport of the patient, they need to be switched off and disconnected and thus switched to passive

5 humidification.

Hence, an improved humidifier would be advantageous, and in particular a humidifier for use in a patient ventilation circuit, which can be integrated within a respirator, would be advantageous.

Furthermore, efficient humidifier would be advantageous, and in particular a  
10 humidifier for use in a patient ventilation circuit, which can continue active humidification during the transport of the patient, would be advantageous.

A low cost, lightweight humidifier would also be advantageous, and in particular a humidifier for use in a patient ventilation circuit, which has a fast response rate, would be advantageous.

15 An improved humidifier would also be advantageous, and in particular a more efficient and compact humidifier for use in a patient ventilation circuit would be advantageous.

## OBJECT OF THE INVENTION

20 It is an object of the present invention to provide a humidifier that can be integrated with the ventilator allowing it to continue humidification during transport of a patient.

It is a further object of the invention to provide a humidifier that is compact, lightweight and low cost.

25 It is a further object of the present invention to provide an alternative to the prior art.

In particular, it may be seen as an object of the present invention to provide a humidifier that solves the above mentioned problems of the prior art by being placed in the inspiratory limb of the patient circuit.

30

## SUMMARY OF THE INVENTION

Thus, the above described object and several other objects are intended to be obtained in a first aspect of the invention by providing a humidifier for use in a patient ventilation circuit, the humidifier comprising: a heater for heating a liquid; a hydrophobic

membrane permeable to the vapour phase of the liquid, wherein the heater for heating the liquid is surrounded by the hydrophobic membrane permeable to the vapour phase of the liquid, thereby allowing for crossing of the membrane only by the vapour phase of the liquid.

5 The humidifier of the invention delivers optimally heated and humidified gas to the patient without the need to special heated-wire patient circuits.

Further the humidifier of the invention is compact and lightweight and adds minimal compliance, resistance and dead-space in the patient circuit.

10 In particular the characterizing position of the heater inside the hydrophobic membrane minimizes the heat loss and therefore improves the power efficiency of the humidifier.

In use, the heater heats the liquid producing vapours that can cross the hydrophobic membrane, as the membrane is permeable to vapour, while the liquid phase is blocked by the membrane.

15 The heater may include any means for heating a liquid, e.g. an ohmic resistance.

The hydrophobic membrane does not allow water, to cross the membrane. However, it is vapour permeable, thus allowing the vapour phase of the liquid to cross the membrane. The membrane surrounds the liquid and the heater, i.e. the heater and liquid are located inside the membrane.

20 Materials that can be used in the hydrophobic membrane may be polymer such as poly fluoro ethylene (PFE).

Generally, the liquid may be an aqueous solution, water based liquid or pure water.

25 In some other embodiments the humidifier further comprises a liquid chamber for containing the liquid.

The liquid is provided to the chamber through a supply line connected to an external water circuit or also simply to water canisters, bags or bottles. This has the advantage of allowing for use of the humidifier also during transportation of the patient.

30 In some other embodiments the humidifier further comprises a temperature sensor for sensing the temperature of the heater.

The temperature sensor may also be able to sense the temperature of the water, in the water chamber. The temperature sensor may also be able to sense the temperature of the air flowing outside the humidifier. These temperatures may be sensed by a single temperature sensor or by more than one sensor.

In some embodiments the temperature sensor is a thermocouple. The thermocouple may be located in between the heater and the liquid chamber sensing the difference in temperature between the liquid chamber and the heater.

5 In some further embodiments the heater for heating a liquid is comprised in a body and the hydrophobic membrane permeable to the vapour phase of the liquid is located onto an external surface of a housing for the body.

The housing may comprise a liquid chamber. The liquid chamber is a volume suitable for containing liquid to be heated by the heater and located between the hydrophobic membrane and the body, i.e. surrounding the body.

10 The liquid is supplied to the humidifier through a liquid channel comprised in the body. The fluid enters the liquid channel at the liquid supply inlet and flows towards the outlet, while is heated by the heater. The outlet of the liquid channel corresponds to the inlet of the liquid chamber comprised in the housing, where the liquid is further heated by the heater.

15 When in use the body is inserted into the housing so that the body is surrounded by the hydrophobic membrane and the vapour produced by heating the liquid, such as water, present in the liquid channel and liquid chamber can be released through the hydrophobic membrane.

In some embodiments the liquid chamber is comprised in the body.

20 In some other embodiments the liquid channel is not comprised in the body.

In some further embodiments the temperature sensor is comprised in the body.

The body may be made of metal, such as aluminium or aluminium alloys.

25 Thus, the body may be a compact metal block where chambers for accommodating the different elements of the humidifier, such as the heater, the temperature sensor and the liquid channel, have been extruded.

30 Thus in a second aspect of the invention a humidifier for use in a patient ventilation circuit is provided, comprising: a body comprising a liquid supply channel, a temperature sensor chamber and a heater chamber; a housing for the body, configured to contain the body, the housing comprising a hydrophobic vapour permeable membrane substantially surrounding the body and located onto at least an external surface of the housing.

The body may comprise a heater inside the heater chamber and a temperature sensor inside the temperature sensor chamber. When in use the heater and the temperature

sensor are connected via wiring to a control unit and a liquid, such as water, is provided to the liquid channel in order to be heated.

The liquid supply channel, also referred to as liquid channel, supplies water to the liquid chamber that may encompass the heater chamber.

5 In other embodiments the body further comprises at least one liquid passage between the liquid channel and the liquid chamber delimited by the hydrophobic membrane.

In other embodiments the housing further comprises at least one inlet of the liquid chamber between the liquid channel and the hydrophobic membrane.

10 The liquid heated by the heater flows through the liquid channel and reaches an outlet of the liquid channel, i.e. a liquid passage between the liquid channel and the hydrophobic membrane. An inlet of the liquid chamber in the housing corresponds to the outlet of the liquid channel in the body allowing the warmed liquid in the liquid channel to flow into the liquid chamber and vaporize, thereby crossing the hydrophobic liquid membrane.

15 Alternatively the outlet of the liquid channel may be comprised in the housing. It may also be that the inlet of the liquid chamber is comprised in the body.

In some embodiments the body is substantially cylindrical and the at least one inlet of the liquid chamber is disposed substantially annularly around the liquid channel.

20 In some further embodiments the heater is placed coaxially to the body and the liquid chamber is disposed substantially annularly around the heater.

In some embodiments the hydrophobic membrane is disposed substantially annularly around the body.

In further embodiments the liquid chamber encompasses the heater.

25 Other locations of the liquid chamber in relation to the heater are possible. In general the heater is configured to heat the liquid chamber, i.e. to heat the liquid contained into the liquid chamber, thus locations of the heater and the liquid chamber are so as to allow for direct or indirect contact between the heater and the liquid chamber. The heater may be in direct contact with the liquid contained in the liquid chamber. The heater may be in indirect contact with the liquid chamber by being in contact with elements that allow for heat transfer  
30 to the liquid chamber and in turn to the liquid therein contained.

In some embodiments the humidifier further comprises at least one fluid passage.

The fluid may be air, thus the fluid passage may be an air passage. The humidifier humidifies the air flowing outside the housing, i.e. at the surface of the

hydrophobic membrane. In order to direct and guide the air towards the area where vapour from the hydrophobic membrane is released, a fluid passage may be present. Thus, when the humidifier is inserted into a respiratory tube or into a connector between a respiratory tube and the outlet of a ventilator, it directs the air flow originated at the outlet of the ventilator towards the respiratory tube through the area where vapour from the hydrophobic membrane is released.

Thus, in some further embodiments the least one fluid passage is configured to allow fluid to flow externally to the hydrophobic membrane permeable to the vapour phase of the liquid.

In some embodiments at least one fluid passage is disposed substantially annularly around at least one part of the body.

The body may be described as comprising a first part and a second part, the first part comprising the at least one fluid passage. When the body is placed in the housing, the second part lies inside the housing, while the first part lies outside the housing.

In some embodiments the first part, comprising the at least one fluid passage has a cross section diameter larger than the cross section diameter of the housing.

Generally the function of the fluid passage is to direct and allow for air flow towards the area where the air is humidified and to hold the humidifier in the centre of the respiratory tube allowing for air flow with minimum restrictions. Thus, the fluid passage may be a single annular tube surrounding the heater. The fluid passage may also be multiple channels radiating from the centre of the body, thus having a spoke like fashion cross section, thereby allowing for minimum resistance to the air flow. The fluid passage may also have a size up to the diameter of the connector or respiratory tube in which the humidifier may be contained.

In some embodiments the humidifier has dimensions allowing it to be contained in a standard respiratory tube. The humidifier is compact and lightweight and can be fully integrated into a respiratory tube or contained in a connector having size of the order of magnitude of the respiratory tube.

The size of the humidifier has great advantages, e.g. it adds minimal compliance, resistance and dead-space in the patient circuit.

Further the reduced size allows for placing of the humidifier in the inspiratory limb, or to integrate it with the ventilator at the outlet port.

For example the size of the humidifier may be in the range between 30 and 180 mm, such as between 50 and 150 mm, preferably between 60 and 130 mm, even more

preferably between 75 and 120 mm. The diameter of the humidifier may be smaller than 50 mm, such as in the range between 40 and 5 mm, preferably smaller than 30 mm, such as in the range between 20 and 10 mm. For example the cross section of the humidifier may have a diameter of 12 mm.

5                   The size of the humidifier allows also for a faster response rate as a larger heating surface heats a small volume of water providing faster evaporation.

                  The described objects and several other objects are intended to be obtained in a third aspect of the invention by providing a respiratory tube comprising a humidifier according to the first aspect of the invention.

10                  The described objects and several other objects are intended to be obtained in a fourth aspect of the invention by providing a ventilation system comprising: a ventilator; a patient circuit comprising an expiration tube and an inspiratory tube, wherein the inspiratory tube comprises a humidifier according to first aspect of the invention.

                  The humidifier comprising the body and the housing may be inserted into the  
15                  inspiratory tube or into a connector that is coupled to the outlet of the ventilator on one side and to the inspiratory tube on the other side allowing for humidification of the air passing through the connector or through the inspiratory tube.

                  The humidifier can be coupled to the ventilator in in any orientation, i.e. 360° at the ventilator outlet port.

20                  The described objects and several other objects are intended to be obtained in a fifth aspect of the invention by providing a disposable housing for a humidifier for use in a patient ventilation circuit, the disposable housing comprising: an inlet, configured to receive a body comprising a heater and a liquid channel; an outlet allowing for release of vapour provided by said body; a compartment located between the inlet and outlet, for housing the  
25                  body; a hydrophobic vapour permeable membrane located at least onto the outlet, thereby allowing vapour to be released externally to the housing.

                  The use of a disposable housing has the advantage of avoiding bacterial contamination as membrane and housing are disposed after each use.

                  The body, i.e. the aluminium core containing the heater, the temperature  
30                  sensor and the liquid channel is re-useable and can be sterilized, e.g. in autoclave.

                  In some further embodiments the disposable housing according to the fifth aspect, further comprises fastening means to fasten the housing to the body.

                  The hydrophobic vapour permeable membrane may be fasten to the housing by fastening means such as crimps.



The invention further relates to a method to humidify air at the outlet of a ventilator, the method comprising inserting a humidifier according to the first aspect of the invention into a connector; placing the connector between the outlet of a ventilator and a respiratory tube, operating the humidifier while air is blown by the ventilator, thereby  
5 providing humidified air at the end of the respiratory tube, i.e. at the proximal part of the respiratory tube.

The main idea of the invention is a humidifier for use in a patient ventilation circuit comprising a heater for heating water and a hydrophobic vapour permeable membrane surrounding the heater in contact with the water, thereby allowing the vapour produced by  
10 heating the water to pass through the membrane, while water in the liquid form is blocked at the surface of the membrane.

The first, second, third and other aspects and embodiments of the present invention may each be combined with any of the other aspects and embodiments. These and other aspects of the invention will be apparent from and elucidated with reference to the  
15 embodiments described hereinafter.

#### BRIEF DESCRIPTION OF THE FIGURES

The humidifier according to the invention will now be described in more detail with regard to the accompanying figures. The figures show one way of implementing the  
20 present invention and is not to be construed as being limiting to other possible embodiments falling within the scope of the attached claim set.

Fig. 1 is a simplified cross-sectional view of a part of a humidifier according to one aspect of the invention.

Fig. 2 is a simplified cross-sectional view of another part of a humidifier  
25 according to some embodiments of the invention.

Fig. 3 is a simplified cross-sectional view of a respiratory tube including a humidifier according to some embodiments of the invention.

Fig. 4 is a perspective view of a ventilator system according to some  
30 embodiments of the invention.

#### DETAILED DESCRIPTION OF AN EMBODIMENT

Fig. 1 is a simplified cross-sectional view of a housing, also referred to as a cartridge, for the core of the humidifier according to one aspect of the invention.

Fig. 1 shows a disposable housing 1 for a humidifier for use in a patient ventilation circuit comprising an inlet 2 configured to receive a body 3. The inlet 2 is an opening in the housing 1 allowing for insertion of a body. The inlet 2 may comprise fastening means 4 designed to mate with a complementary fastening means 5 onto the body 3 as shown in Fig. 2. For example, a helical ridge wrapped around the body 3, i.e. an external thread 5 on body 3 may be used complementary to an internal thread 4 on internal surface of the inlet 2.

Fastening means 4 insure fastening of the body to the housing. To avoid eventual leakage of the liquid, such as water, introduced via liquid channel 6 of body 3, areas 7 are present on the inlet 2 complementary to o-ring seal 38 on body 3.

Fastening means 4 as shown in Fig. 1 and complementary fastening means 5 as shown in Fig. 2 are represented in a nut and bolt fashion. However, other fastening means may be used employing different mechanisms such as interference fit, or press-fit between parts on the housing 1 and on the body 3.

The housing 1 comprises at least one inlet 8 allowing for liquid entering the liquid chamber 37. When in use, the liquid introduced via liquid inlet 12 flows through liquid channel 6 of body 3 reaching the liquid passage or outlet 33 corresponding to the inlet 8 of the liquid chamber 37 in the housing 1. The hydrophobic membrane 9 is hydrophobic, i.e. water, introduced via liquid channel 6 of body 3 and present in the liquid chamber 37, due to intermolecular interactions does not maintain contact with the membrane. The hydrophobic membrane 9 is permeable to vapour, i.e. the vapour produced by heating the liquid in the liquid chamber 37 and liquid channel 6 getting in contact with membrane 9 crosses the membrane, while liquid is not able to pass.

The housing 1 comprises also means for fastening the hydrophobic membrane 9 to the external surface of the housing, such as crimps 32.

The housing 1 is disposable as after use may be removed by, e.g. unscrewing it from its core, i.e. the body 3 and replaced with a new housing.

The body 3 may be reused and it may be easily sterilised, e.g. in an autoclave.

Fig. 2 is a simplified cross-sectional view of the core, i.e. body 3, of a humidifier according to some embodiments of the invention.

The core, i.e. body 3, of the humidifier comprises a liquid, such as water, supply channel 6, a temperature sensor chamber 10 and a heater chamber 11.

Liquid, such as water flows into the water supply channel 6 through a water supply port 12 which can be connected via tubing or can be snapped directly to a water bottle or a water canister. Optionally the supply of water to the water channel 6 and in turn to the

water chamber 37 can be controlled through the presence of a leak sensor probe detecting water leak in any orientation. In this way the water supply to the humidifier can be easily shut down if needed.

5 The temperature sensor chamber 10 accommodates a temperature sensor, such as a thermocouple for temperature control of the humidifier.

The heater chamber 11 accommodates a heater element. The temperature sensor may sense the temperature of the heater element inside the heater chamber and eventually control its temperature through a control unit (not shown).

10 The body 3 may be made of metal, such as a heat conductive metal. For example body 3 may be made of aluminium or aluminium alloys. Thus, heater element, temperature sensor and water supply channel 6 are enclosed into a shell of conductive metal.

The body 3 comprises also a fastening mean complementary to the one in the housing, e.g. an external thread 5 complementary to internal thread 4 on the internal surface of the housing 1.

15 The body 3 may further comprise o-ring seal 38 that when the housing is sealed with the body to ensure from eventual liquid leakage.

20 The body 3 may comprise a first part 17 and a second part 16. When the body is placed into the housing the second part 16 lies completely inside the housing 1, while the first part 17 lies outside the housing 1. The first part 17 may comprise at least one passage 18 allowing the flow 22 of the air from the outlet 34 of a ventilator to reach the area 23 where the air is humidified and heated before entering the respiratory tube 15, as shown in Fig. 3. Passage 18 may be disposed substantially annularly around body 3 as shown in Fig. 2. In some other embodiments the passage 18 may be placed differently. Generally the passage is adapted to allow air flow towards area 23 and/or in contact with the external surface of the  
25 membrane 9 of housing 1.

In some embodiments the fluid passage is not comprised in the body 3.

30 In Fig. 2 and 3 the passage 18 is represented having a specific diameter. However, the diameter of the fluid passage may vary, e.g. up to the diameter of the connector or respiratory tube in which the humidifier is contained. The passage 18 is designed so as to allow for air flow with minimum restrictions. Thus optimization of dimension and shape of the passage may be achieved and implemented by means of computer simulation and/or experimentation directed towards minimization of air flow restrictions.

Fig. 3 is a simplified cross-sectional view of a respiratory tube including a humidifier according to the embodiment of the invention.

A humidifier 13 comprising a core 3 and a housing 1 as shown in Fig. 3 is located inside a connector 14 connecting the outlet 34 of a ventilator (not shown) with a respiratory tube 15, such as an inspiratory tube.

The humidifier 13 is placed coaxially inside the connector 14. However in  
5 other embodiments the humidifier 13 may be placed differently to further minimize resistance in the respiratory tube 15 of the patient circuit.

Optionally the o-rings 35 may be used to insure tight connection between the connector 14 and the outlet 34.

Leak sensor probe 36 may be positioned inside the connector 14 to detect and  
10 avoid leakage.

Fig. 3 shows also the electrical connection 19 to the temperature sensor inside chamber 10 and electrical connection 20 to supply the heater inside chamber 11 with electricity. Water is supplied via tubing 21.

In some embodiments the humidifier 13 may be placed directly inside  
15 respiratory tube 15.

When in use, air generated via a ventilator system (not shown) reaches the respiratory tube via an outlet 34. Here air flow in the direction of arrows 22 and through passage 18 reaches area 23 of connector 14, surrounding the humidifier 13. Inside humidifier  
20 13 the water present in chamber 10 and provided via tubing 21 is heated by the heater element located inside heater chamber 11. Heating of the liquid produces vapours that, passing through the hydrophobic, vapour permeable membrane 9 of the housing 1, are released in the area 23. The flow of air passing through area 23 gets therefore humidified and heated before entering the respiratory tube 15.

Fig. 4 is a perspective view of a ventilator system according to some  
25 embodiments of the invention. A ventilator 24 has an air outlet 25 and an air inlet 26 respectively connected to an inspiratory tube 27, also referred to as inhalation limb and an expiratory tube 28, referred to as exhalation limb. From Fig. 4 it can be noticed that due to its limited size, humidifier 29 may be easily integrated into the inhalation limb 27 of the ventilation system 30.

The humidifier of the invention may be used for adult, paediatric and neonatal  
30 ventilation therapies that require heated humidification of gases for home or hospital use. This humidifier may also have applicability to other gas humidification products.

Although the present invention has been described in connection with the specified embodiments, it should not be construed as being in any way limited to the

presented examples. The scope of the present invention is set out by the accompanying claim set. In the context of the claims, the terms “comprising” or “comprises” do not exclude other possible elements or steps. Also, the mentioning of references such as “a” or “an” etc. should not be construed as excluding a plurality. The use of reference signs in the claims with  
5 respect to elements indicated in the figures shall also not be construed as limiting the scope of the invention. Furthermore, individual features mentioned in different claims, may possibly be advantageously combined, and the mentioning of these features in different claims does not exclude that a combination of features is not possible and advantageous.

## CLAIMS:

1. A humidifier (13) for use in a patient ventilation circuit, said humidifier comprising:
  - a heater (11) for heating a liquid,
  - a hydrophobic membrane (9) permeable to the vapour phase of said liquid,5 wherein said heater for heating said liquid is surrounded by said hydrophobic membrane permeable to the vapour phase of said liquid, thereby allowing for crossing of said membrane only by the vapour phase of said liquid.
2. A humidifier according to claim 1 further comprising a liquid chamber (37) 10 for containing said liquid.
3. A humidifier according to claim 1 or 2 further comprising a temperature sensor (10) for sensing the temperature of said heater.
- 15 4. A humidifier according to claims 1 or 2, wherein said heater (11) for heating a liquid is comprised in a body (3) and said hydrophobic membrane (9) permeable to the vapour phase of said liquid is located onto an external surface of a housing (1) for said body.
5. A humidifier according to claims 1 or 2, wherein said liquid chamber (37) 20 encompasses said heater.
6. A humidifier according to claim 4, wherein said housing further comprises at least one inlet (8) of said liquid chamber (37) between said liquid channel (6) and said hydrophobic membrane (9). 25
7. A humidifier according to claim 6, wherein said body (3) is substantially cylindrical and said at least one inlet (8) of said liquid chamber (37) is disposed substantially annularly around said liquid channel (6).

8. A humidifier according to claims 6 or 7, wherein said heater is placed coaxially to said body and said liquid chamber (37) is disposed substantially annularly around said heater (11).

5 9. A humidifier according to claims 6 or 7, wherein said hydrophobic membrane (9) is disposed substantially annularly around said body (3).

10. A humidifier according to claims 1, 2, 6 or 7, further comprising at least one fluid passage (18).

10

11. A humidifier according to claims 1, 2, 6 or 7, said humidifier having dimensions allowing to be contained in a standard respiratory tube.

12. A respiratory tube (27) comprising a humidifier (29) according to claim 1.

15

13. A ventilation system (30) comprising:

- a ventilator (24);
- a patient circuit comprising an expiration tube (28) and an inspiratory tube (27), said inspiratory tube (27) comprising a humidifier (29) according to claim 1.

20

14. A disposable housing (1) for a humidifier for use in a patient ventilation circuit, said disposable housing comprising

- an inlet (2), configured to receive a body (3), said body comprising a heater (11) and a liquid channel (6);

25

- an outlet (8) allowing for release of vapour provided by said body,
- a chamber (31) located between said inlet (2) and outlet (8), for housing said body;
- a hydrophobic vapour permeable membrane (9) located at least onto said outlet (8), thereby allowing vapour to be released externally to said housing.

30

15. A disposable housing (1) according to claim 14, said disposable housing further comprising fastening means (4) to fasten said housing to said body.

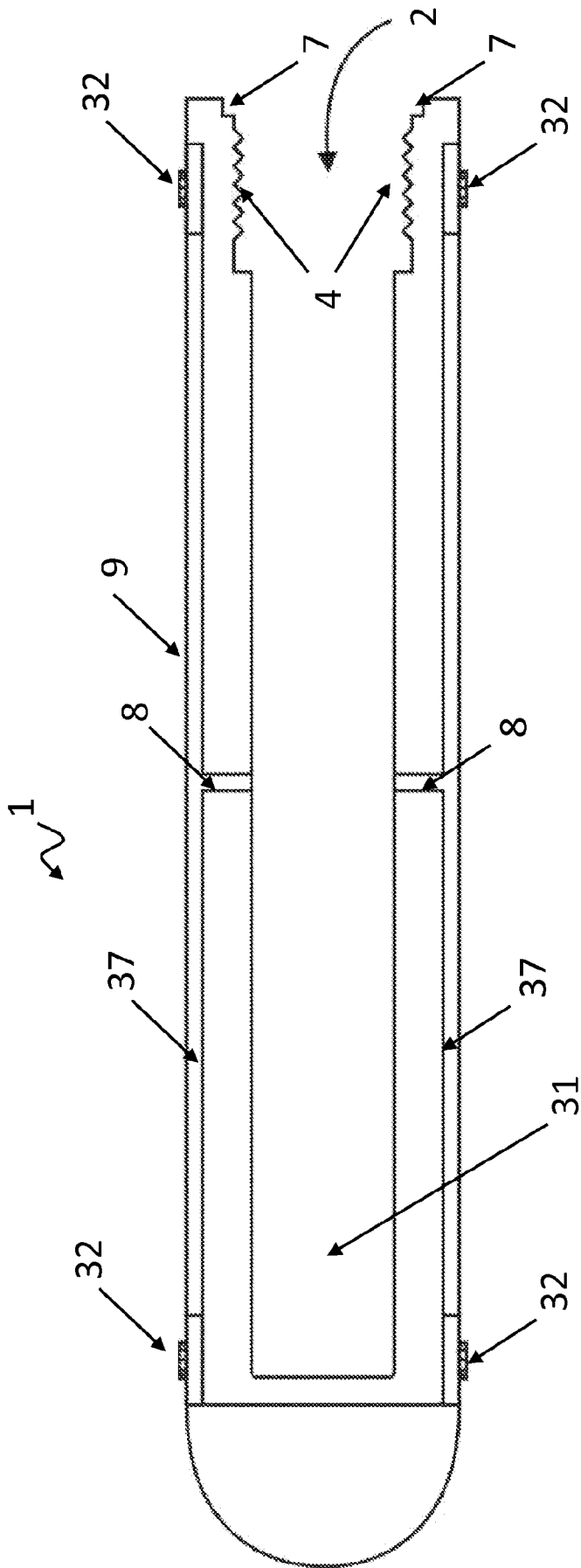

FIG. 1



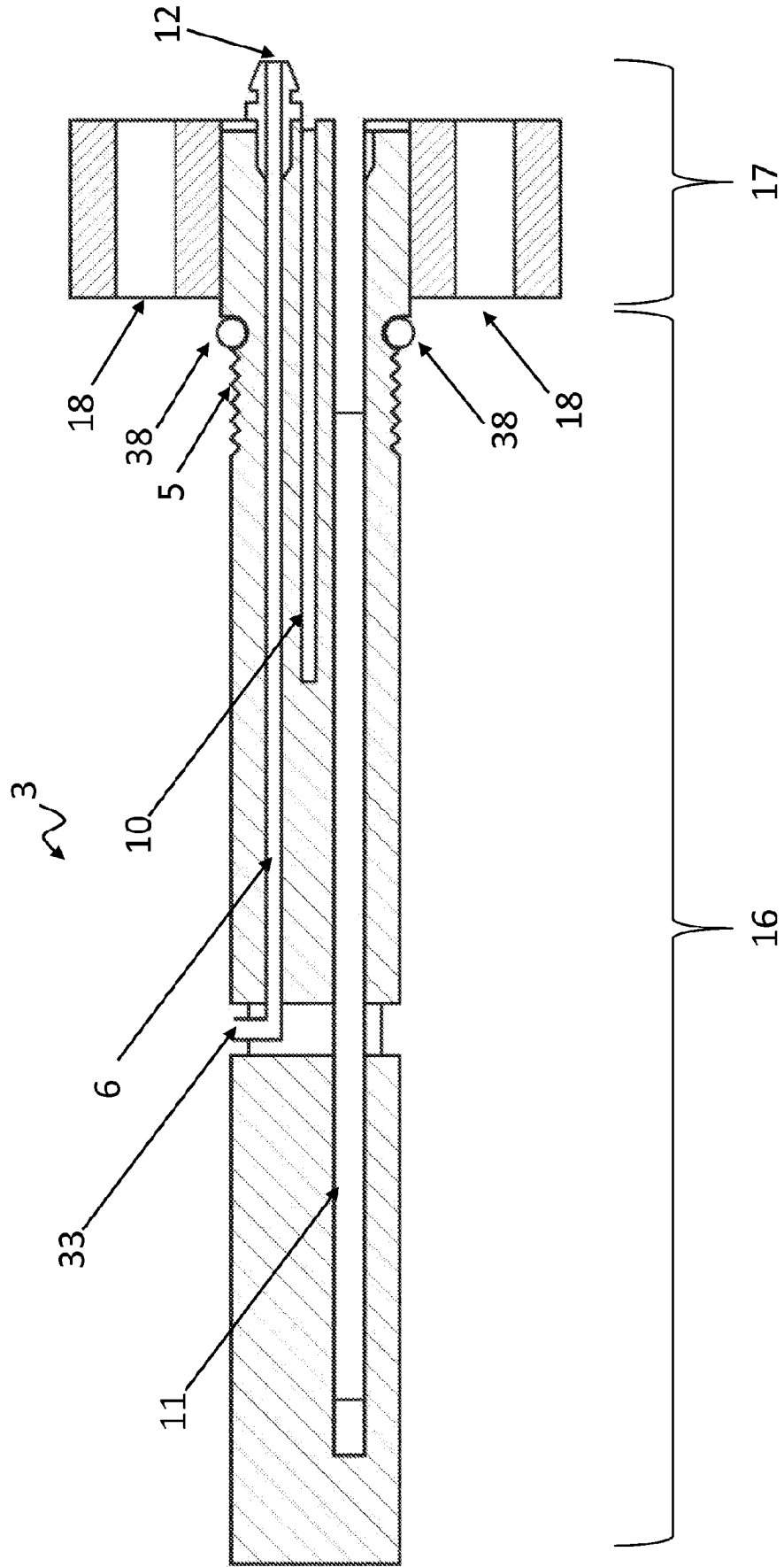

FIG. 2

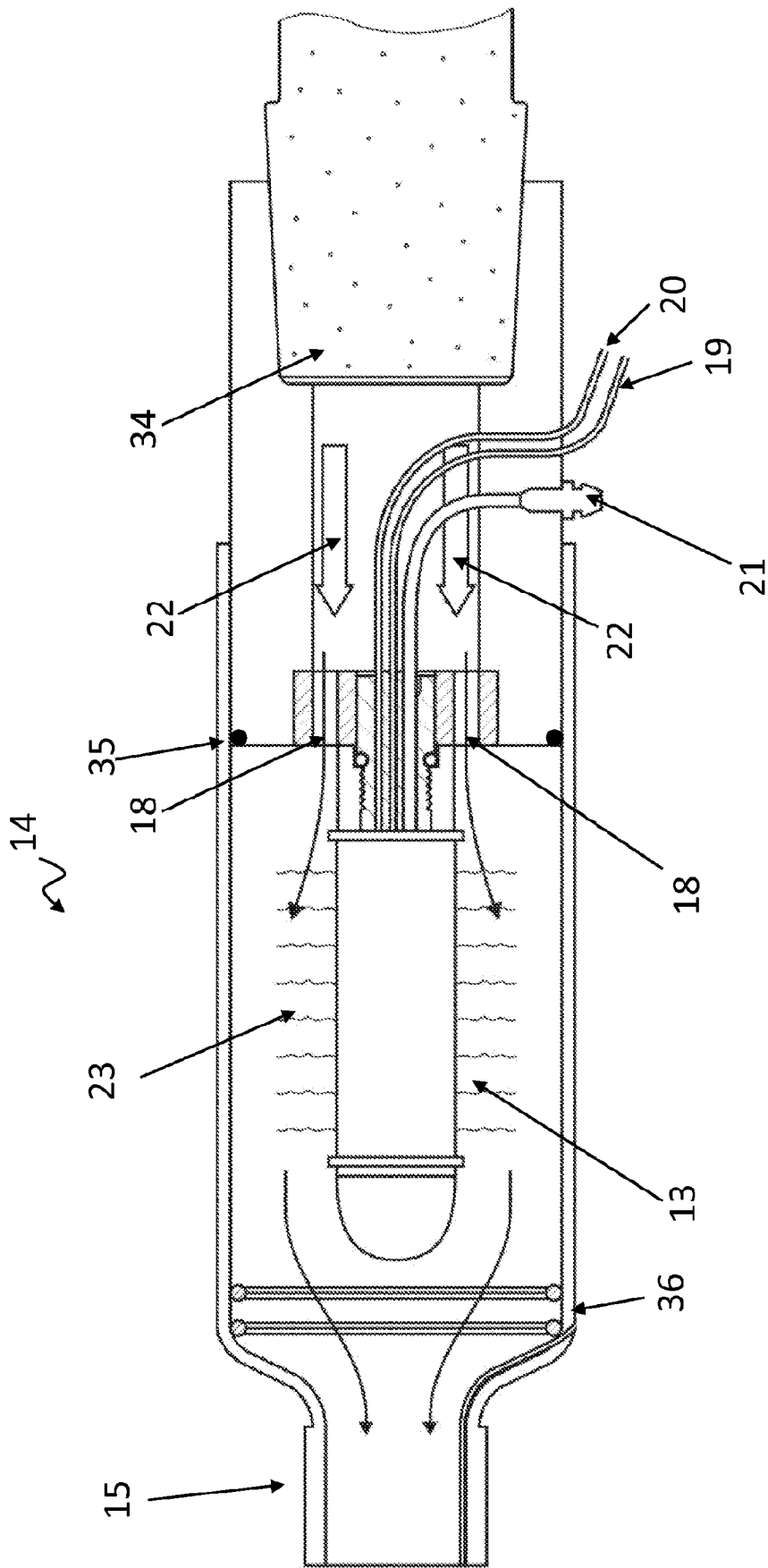

FIG. 3

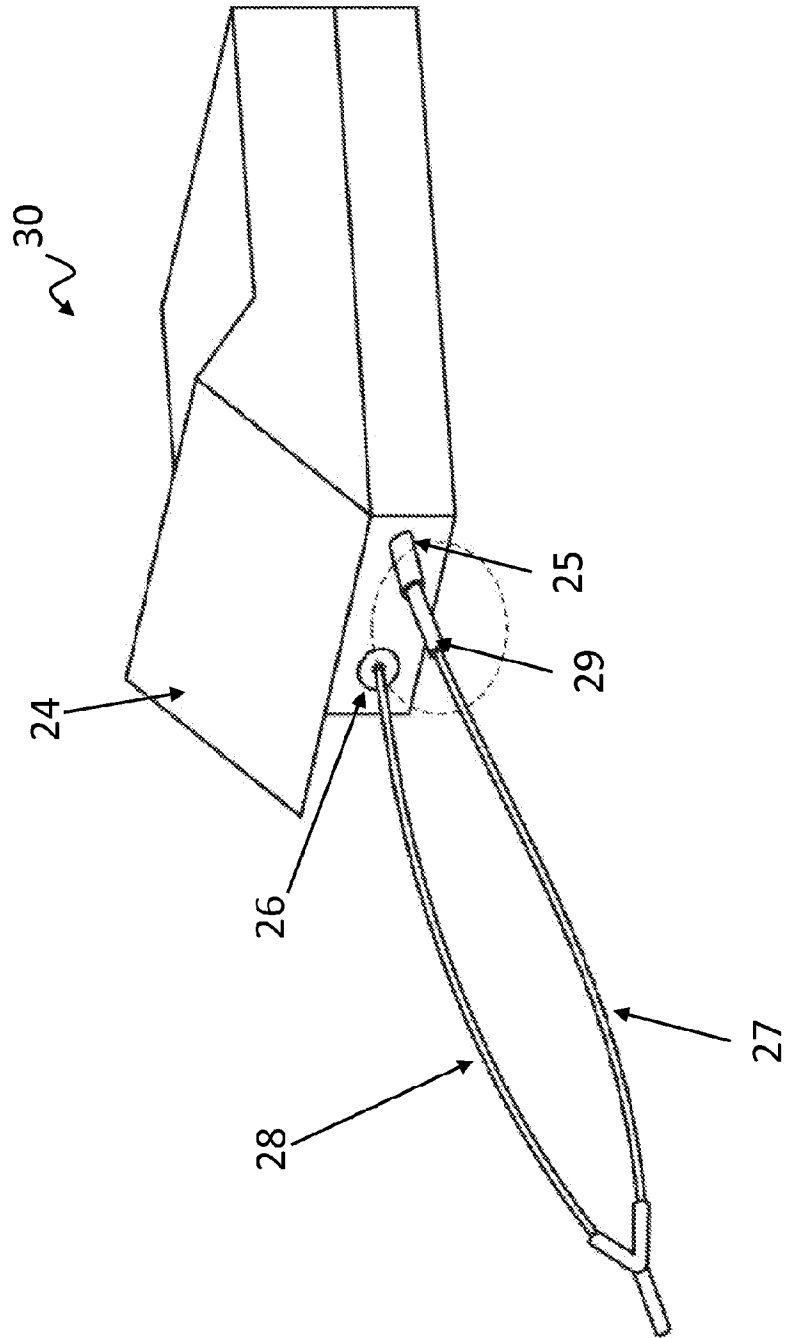

FIG. 4

## INTERNATIONAL SEARCH REPORT

International application No  
PCT/IB2013/055439

A. CLASSIFICATION OF SUBJECT MATTER INV. A61M16/08 A61M16/16 A61M16/10 H05B3/40 ADD.		
According to International Patent Classification (IPC) or to both national classification and IPC		
B. FIELDS SEARCHED		
Minimum documentation searched (classification system followed by classification symbols) A61M H05B B01D		
Documentation searched other than minimum documentation to the extent that such documents are included in the fields searched		
Electronic data base consulted during the international search (name of data base and, where practicable, search terms used) EPO-Internal, WPI Data		
C. DOCUMENTS CONSIDERED TO BE RELEVANT		
Category*	Citation of document, with indication, where appropriate, of the relevant passages	Relevant to claim No.
A	EP 0 521 726 A1 (JAPAN GORE TEX INC [JP]) 7 January 1993 (1993-01-07) abstract column 1, lines 1-20 -----	1-13
X	US 2003/192953 A1 (NITTA KAZUFUKU [JP]) 16 October 2003 (2003-10-16) -----	1-6, 10-12, 14,15 13
Y	abstract; figures 1-4,9, 15 paragraphs [0041] - [0048], [0055] -----	
X	WO 03/099367 A2 (ANTHONY JEAN-MICHEL [BE]) 4 December 2003 (2003-12-04) -----	1-10
Y	abstract; figures 2,3 page 8, lines 1-32 page 9, lines 1-15 -----	13
	-/--	
<input checked="" type="checkbox"/> Further documents are listed in the continuation of Box C. <input checked="" type="checkbox"/> See patent family annex.		
* Special categories of cited documents :		
"A" document defining the general state of the art which is not considered to be of particular relevance	"T" later document published after the international filing date or priority date and not in conflict with the application but cited to understand the principle or theory underlying the invention	
"E" earlier application or patent but published on or after the international filing date	"X" document of particular relevance; the claimed invention cannot be considered novel or cannot be considered to involve an inventive step when the document is taken alone	
"L" document which may throw doubts on priority claim(s) or which is cited to establish the publication date of another citation or other special reason (as specified)	"Y" document of particular relevance; the claimed invention cannot be considered to involve an inventive step when the document is combined with one or more other such documents, such combination being obvious to a person skilled in the art	
"O" document referring to an oral disclosure, use, exhibition or other means	"&" document member of the same patent family	
"P" document published prior to the international filing date but later than the priority date claimed		
Date of the actual completion of the international search  21 November 2013	Date of mailing of the international search report  28/11/2013	
Name and mailing address of the ISA/ European Patent Office, P.B. 5818 Patentlaan 2 NL - 2280 HV Rijswijk Tel. (+31-70) 340-2040, Fax: (+31-70) 340-3016	Authorized officer  Moraru, Liviu	

## INTERNATIONAL SEARCH REPORT

International application No

PCT/IB2013/055439

C(Continuation). DOCUMENTS CONSIDERED TO BE RELEVANT		
Category*	Citation of document, with indication, where appropriate, of the relevant passages	Relevant to claim No.
X	US 5 062 145 A (ZWAAN PAUL [NZ] ET AL) 29 October 1991 (1991-10-29) abstract; figure 7 column 2, lines 49-68 column 3, lines 1-28 -----	1-5,10
X	US 5 367 604 A (MURRAY CHARLES G [NZ]) 22 November 1994 (1994-11-22) abstract; figure 1 column 3, line 66 - column 4, line 62 -----	1-5,10
Y	WO 2012/077052 A1 (KONINKL PHILIPS ELECTRONICS NV [NL]; ARCILLA MABINI [US]) 14 June 2012 (2012-06-14) abstract; figure 1 -----	13
A		1-12
Y	US 6 510 848 B1 (GIBERTONI LUCIO [IT]) 28 January 2003 (2003-01-28) the whole document -----	13
A		1-12
A	EP 1 281 413 A2 (SENKO MED INSTR MFG [JP]) 5 February 2003 (2003-02-05) the whole document -----	1-15

## INTERNATIONAL SEARCH REPORT

Information on patent family members

International application No

PCT/IB2013/055439

Patent document cited in search report	Publication date	Patent family member(s)	Publication date
EP 0521726	A1	07-01-1993	DE 69216697 D1 27-02-1997
			DE 69216697 T2 12-06-1997
			EP 0521726 A1 07-01-1993
			JP 2688662 B2 10-12-1997
			JP H0518572 A 26-01-1993
			US 5273689 A 28-12-1993
-----			
US 2003192953	A1	16-10-2003	AU 719885 B2 18-05-2000
			AU 3186797 A 09-02-1998
			CA 2261594 A1 22-01-1998
			DE 69735060 T2 27-07-2006
			EP 0934091 A1 11-08-1999
			ES 2251027 T3 16-04-2006
			JP H1028737 A 03-02-1998
			KR 20000023824 A 25-04-2000
			US 6394084 B1 28-05-2002
			US 2002170559 A1 21-11-2002
			US 2003192953 A1 16-10-2003
			WO 9802199 A1 22-01-1998
-----			
WO 03099367	A2	04-12-2003	AT 357944 T 15-04-2007
			AU 2003237692 A1 12-12-2003
			DE 60312849 T2 04-10-2007
			EP 1507568 A2 23-02-2005
			ES 2283782 T3 01-11-2007
			JP 2005527305 A 15-09-2005
			US 2006012057 A1 19-01-2006
			WO 03099367 A2 04-12-2003
-----			
US 5062145	A	29-10-1991	AU 614875 B2 12-09-1991
			AU 4175189 A 05-04-1990
			DE 3932766 A1 05-04-1990
			FR 2636845 A1 30-03-1990
			GB 2223694 A 18-04-1990
			GB 2252515 A 12-08-1992
			JP H02193680 A 31-07-1990
			NZ 226784 A 28-10-1992
			US 5062145 A 29-10-1991
-----			
US 5367604	A	22-11-1994	AU 3713193 A 28-10-1993
			EP 0567158 A2 27-10-1993
			JP H0663139 A 08-03-1994
			US 5367604 A 22-11-1994
-----			
WO 2012077052	A1	14-06-2012	NONE
-----			
US 6510848	B1	28-01-2003	US 6510848 B1 28-01-2003
			US 2003127095 A1 10-07-2003
			US 2005166915 A1 04-08-2005
-----			
EP 1281413	A2	05-02-2003	EP 1281413 A2 05-02-2003
			JP 2003111774 A 15-04-2003
			NZ 520208 A 28-02-2003
			US 2003028139 A1 06-02-2003
-----			