

*M. K. Pierce,*  
*Screen-Threading Metal Pipe.*  
*N<sup>o</sup> 104,196.*                      *Patented June 14, 1870.*

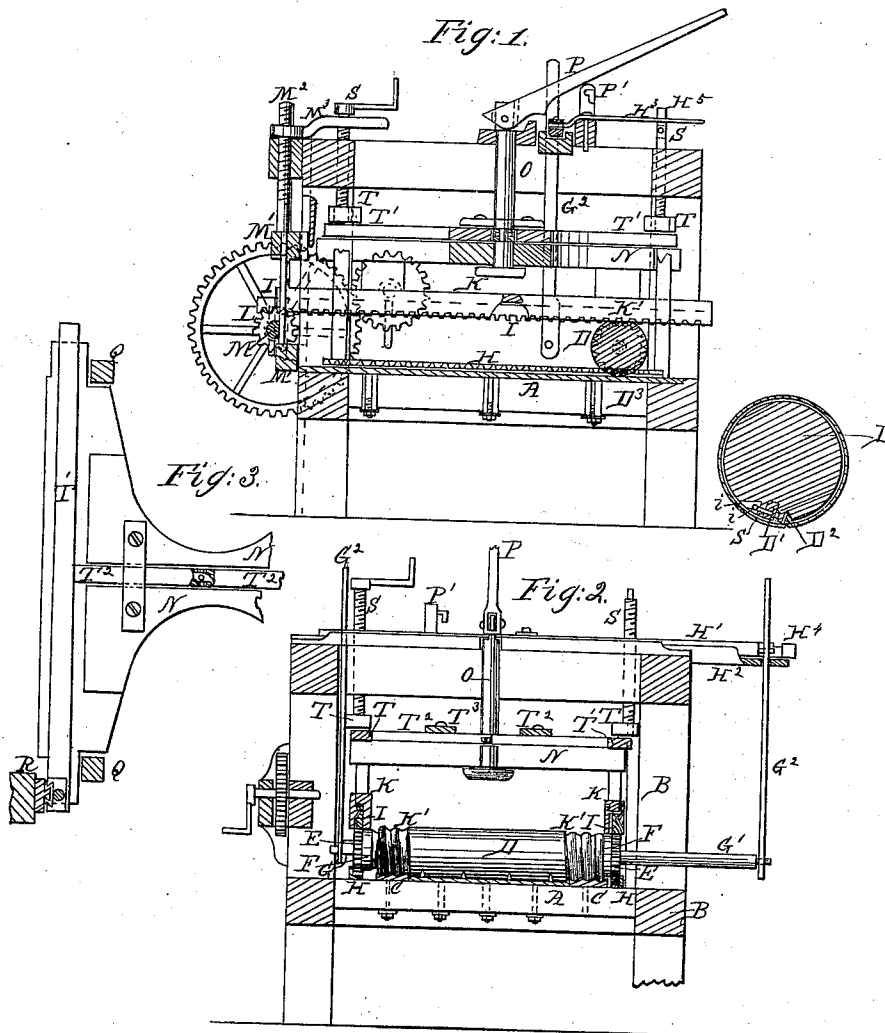

Witnesses

*J. Baker*  
*Edgar L. ...*

Inventor

*M. K. Pierce*  
*M. K. Pierce*

# United States Patent Office.

M. K. PIERCE, OF CALAHAN'S RANCH, CALIFORNIA.

Letters Patent No. 104,196, dated June 14, 1870.

## IMPROVED SHEET-METAL-PIPE FORMING AND THREADING-MACHINE.

The Schedule referred to in these Letters Patent and making part of the same.

### To all whom it may concern:

Be it known that I, M. K. PIERCE, of Calahan's Ranch, in the county of Siskiyou and State of California, have invented a new and improved Sheet-metal-pipe Forming and Threading-Machine; and I do hereby declare that the following is a full, clear, and exact description thereof, which will enable others skilled in the art to make and use the same, reference being had to the accompanying drawing forming part of this specification.

This invention relates to new and useful improvements in machinery for forming sheet-metal pipe and forming screw-threads on them.

It consists in the combination with a bed-plate, having oblique grooves and ribs along each margin, of a forming-roller, having spiral-grooves and projections at the ends, so corresponding to those on the bed that, when placed thereon, its projections will fit in the grooves of the bed, and the projections of the latter will fit in the grooves of the former, and operating gear for pressing the roller down upon a sheet placed between it and the bed, and attached at one end to the roller, and rolling the latter along the bed, to impart, by the said grooves and projecting spiral threads to the sheet, which is rolled up at the same time into tubular form, and forced upon punches, which are so arranged in the bed as to punch the lapping edges of the plate, to form the rivet-holes for connecting them.

Figure 1 a sectional elevation of my improved machine.

Figure 2 is a transverse section of the same, and

Figures 3 and 4 are details.

Similar letters of reference indicate corresponding parts.

A is a table or bed, supported in a strong rectangular framing, B, and having on each side a plate or bar, C, with grooves and projections corresponding to the grooves and projections of the screw-thread required on the pipe to be formed. These grooves and projections are pitched obliquely to the longitudinal axis of the table, according to the pitch required for the screw.

D is a cylinder, having on each end spiral threads or grooves and projections, so arranged relatively to the plates C that the projections of one fit the grooves of the other. This cylinder has gear-teeth E, friction-wheels F, and projecting axles G G', the latter being longer than the former.

On each side of the table A is a toothed rack, H, in which the teeth E of the cylinder are designed to work, and above these racks are other racks, I, also designed for the said teeth to gear with, and arranged to slide back and forth on beams K, by which they are supported. They also gear with pinions L on the shaft M, at the end of the machine, on which is a large

toothed wheel, by which the operating force is applied. These beams K are supported on a frame, N, suspended by a rod, O, from a lever, P, at the top of the frame, between vertical guides Q R, so as to be lowered down upon the cylinder to impart the pressure, or to be raised to admit the roller to be raised for applying the plates to be formed and to remove those acted upon, the said pressure being applied to the frame N by the screws S and blocks T, which are screwed down upon the frame after the plate has been placed under the roller, forcing the parts K' of the beams K down upon the friction-rollers F.

The frame N is raised by the lever P and rod O by forcing the said lever down; the latter is held down and the frame up by swinging it to the right previous to forcing it down, to engage it with the hook P'.

In order to provide space under the blocks T for thus raising the frame N, I have provided sliding bars T' on the frame N, under the blocks, and connected them by bars T<sup>2</sup> to pins or arms T<sup>3</sup> on the rod O, by which, when the lever is turned around, as above described, to engage with the hook P', the bars T' will be drawn from under the blocks. After the frame is let down, the lever P is turned back to the left, thereby forcing the plates back under the blocks.

The projecting axles G G' of the roller are connected to bars G<sup>2</sup>, suspended from a lifting device at the top for raising the cylinder off the bed for shifting the plates.

The lifting device consists of a sliding-bar, H<sup>1</sup>, arranged in a groove or race in a transverse beam, H<sup>2</sup>, and a vibrating and lifting lever, H<sup>3</sup>, the said beam being provided with vertical holes for the passage of the bars G<sup>2</sup>, and the sliding bar H<sup>1</sup>, having pins H<sup>4</sup>, arranged to be forced through holes in the bars G<sup>2</sup> by the lever H<sup>3</sup>, when they are caused to stand vertically by suitably adjusting the roller, so that, by pressing the long arm of the lever H<sup>3</sup> down over its fulcrum, after the pins have been thrust in the holes in the said bars, the roller will be raised. This lever is engaged with the catch H<sup>5</sup> for holding the roller up.

The latter is provided with a longitudinal groove in its surface for the reception of a clamping-bar, D, which is secured by small screws passing through the radial longitudinal ribs, said bar being designed for holding the end of the sheet to be formed, which is inserted between the wall of the groove and the bar, and the latter is secured or otherwise pressed against the said end.

The said roller is also provided with a row of holes, D<sup>2</sup>, for the reception of the punches D<sup>3</sup>, fixed in the bed, and adjusted relatively to the roller, for punching the sheet at the parts where the two ends lap, to form the holes for riveting them together.

The roller, after having the sheet attached as de-

scribed, is placed in position on the bed, and in connection with the toothed racks, care being taken to so place it that, when it has performed one revolution, the holes  $D^2$  will arrive at and coincide with the punches to receive them in punching the holes. The frame  $N$  is then let down in the manner described, and the wheel on the shaft  $M$  set in motion, to draw the rack-bars  $I$ , and roll the cylinder along, by which the threads will be formed in the sheet, and the latter will be bent up to form the tube.

For making different sizes of tubes, cylinders  $D$ , of different sizes, are used; and the screws  $S$  are adjusted higher or lower, as required, and, to accommodate the pinions  $L$  and shaft  $M$  to the variations of the frame  $N$  and rack bars  $I$ , the bearings of the said shaft are connected to a vertically-adjustable frame,  $M^1$ , fixed to slide on the end of the frame, and provided with an adjusting-screw,  $M^2$ , and adjusting-nut,  $M^3$ . I propose to arrange the punches  $D^2$  in the bed for adjustment along the same as may be required for rollers of different sizes.

Having thus described my invention,

I claim as new and desire to secure by Letters Patent—

1. The combination of the bed  $A$ , plates  $C$  with oblique grooves and projections, and cylinder  $D$  with grooves and projections fitting those in the plates  $C$ , all arranged for operation substantially as specified.

2. The combination with the bed  $A$ , plates  $C$ , spirally-grooved cylinder  $D$  and the toothed racks  $H$   $I$ , pinions  $E$ , and friction-rollers, substantially as specified.

3. The combination with the spirally-grooved cylinder  $D$ , and toothed racks  $I$  of the guide-beams  $K$ , and pressing-frame  $N$ , substantially as specified.

4. The combination with the frame  $N$  of the sliding plates  $T^1$ , adjusting screws  $S$ , blocks  $T$ , arms  $T^2$ , lifting and oscillating rod  $O$ , and lever  $P$ , substantially as specified.

5. The combination with the spirally-grooved cylinder  $D$  of the lifting bars  $G^2$ , beam  $H^2$ , bars  $H^1$ , and lever  $H^3$ , all substantially as specified.

6. The combination, with the rack-bars  $I$  and adjustable frame  $N$ , of the vertically-adjustable frame  $M^1$ , driving-shaft  $M$ , and pinions  $L$ , all substantially as specified.

7. The combination, with the bed  $A$ , plate  $C$ , and spirally-grooved roller  $D$ , of the punches  $D^2$ , substantially as specified.

8. The cylinder  $D$ , provided with the projecting axles  $G^1$   $G^1$ , punch-holes  $D^2$ , clamping-bar  $D^1$ , and clamping-screws, all substantially as specified.

M. K. PIERCE.

Witnesses:

J. W. BLACKBURN,  
I. A. DENNY.