



(86) Date de dépôt PCT/PCT Filing Date: 2004/10/20
 (87) Date publication PCT/PCT Publication Date: 2005/05/06
 (45) Date de délivrance/Issue Date: 2013/10/08
 (85) Entrée phase nationale/National Entry: 2006/04/19
 (86) N° demande PCT/PCT Application No.: EP 2004/011953
 (87) N° publication PCT/PCT Publication No.: 2005/039648
 (30) Priorité/Priority: 2003/10/20 (EP03078086.0)

(51) Cl.Int./Int.Cl. *C07D 473/18* (2006.01),
A61K 47/48 (2006.01), *A61K 51/04* (2006.01),
A61P 35/00 (2006.01), *C07C 229/76* (2006.01),
C07D 209/20 (2006.01), *C07D 231/12* (2006.01),
C07D 233/58 (2006.01)
 (72) Inventeurs/Inventors:
 ALBERTO, ROGER, CH;
 ZOBİ, FABIO, CH
 (73) Propriétaire/Owner:
 UNIVERSITAET ZUERICH, CH
 (74) Agent: OSLER, HOSKIN & HARCOURT LLP

(54) Titre : UTILISATION DE COMPLEXES METAL/TRICARBONYLE EN TANT QU'AGENTS CHIMIOTOXIQUES ET
 RADIOTHERAPEUTIQUES

(54) Title: USE OF METAL TRICARBONYL COMPLEXES AS RADIOTHERAPEUTIC CHEMOTOXIC AGENTS

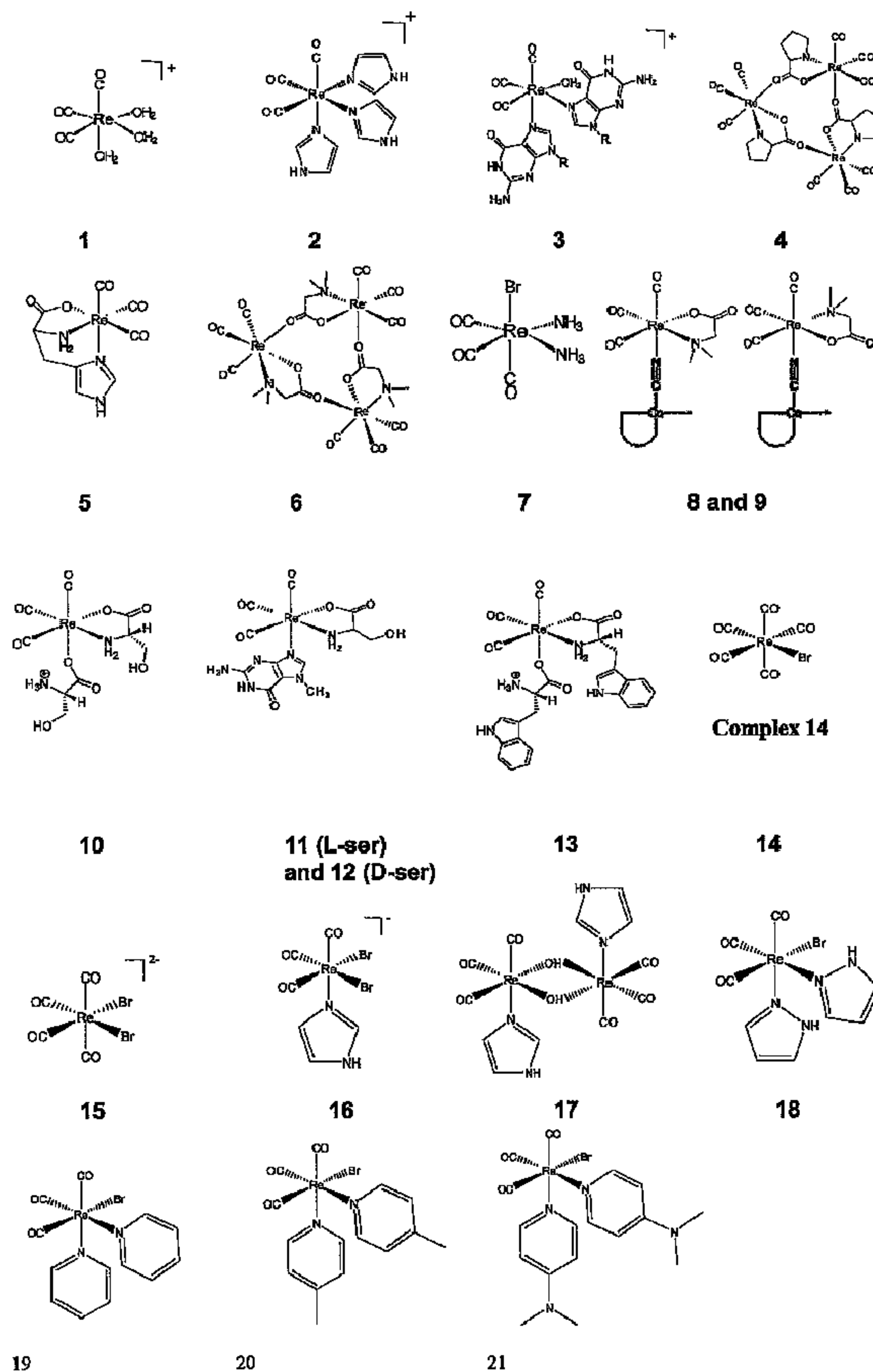

(57) Abrégé/Abstract:

The invention relates to the use of metal tricarbonyl compounds of the general formula $[M(CO)_3L]$, wherein M is rhenium or technetium or an isotope thereof and L is a ligand, for the preparation of a medicament for the treatment of cancer that is both

(57) **Abrégé(suite)/Abstract(continued):**

radiotherapeutic and chemotoxic when a radioactive metal is used and chemotoxic when cold rhenium or macroscopic amounts of long-lived Tc-99 is used. The medicament is in particular chemotoxic by causing intrastrand linkages in DNA. In a specific embodiment at least one of L is not OH₂. The invention further relates to novel compounds of the general formula $M(CO)_3X_1X_2X_3$ and their use, wherein M is rhenium or technetium or an isotope thereof and at least one of X₁, X₂ and X₃ is a monodentate ligand; or two of X₁, X₂ and X₃ are part of a bidentate ligand and the other one is optionally a monodentate ligand.

(12) INTERNATIONAL APPLICATION PUBLISHED UNDER THE PATENT COOPERATION TREATY (PCT)

(19) World Intellectual Property
Organization
International Bureau



(43) International Publication Date
6 May 2005 (06.05.2005)

PCT

(10) International Publication Number
WO 2005/039648 A3

- (51) International Patent Classification⁷: **A61K 51/04**, 51/08, A61P 35/00
- (21) International Application Number: PCT/EP2004/011953
- (22) International Filing Date: 20 October 2004 (20.10.2004)
- (25) Filing Language: English
- (26) Publication Language: English
- (30) Priority Data: 03078086.0 20 October 2003 (20.10.2003) EP
- (71) Applicant (for all designated States except US): **UNIVERSITÄT ZÜRICH** [CH/CH]; Winterthurerstrasse 190, CH-8057 Zürich (CH).
- (72) Inventors; and
- (75) Inventors/Applicants (for US only): **ALBERTO, Roger** [CH/CH]; St. Georgenstrasse 54, Ch-8400 Winterthur (CH). **ZOBI, Fabio** [IT/CH]; Sandacker 12, CH-8052 Zürich (CH).
- (74) Agent: **VAN SOMEREN, PETRONELLA FRANCISCA HENDRIKA MARIA**; Arnold & Siedsma, Sweelinckplein 1, NL-2517 GK The Hague (NL).
- (81) Designated States (unless otherwise indicated, for every kind of national protection available): AE, AG, AL, AM, AT, AU, AZ, BA, BB, BG, BR, BW, BY, BZ, CA, CH, CN, CO, CR, CU, CZ, DE, DK, DM, DZ, EC, EE, EG, ES, FI, GB, GD, GE, GH, GM, HR, HU, ID, IL, IN, IS, JP, KE, KG, KP, KR, KZ, LC, LK, LR, LS, LT, LU, LV, MA, MD, MG, MK, MN, MW, MX, MZ, NA, NI, NO, NZ, OM, PG, PH, PL, PT, RO, RU, SC, SD, SE, SG, SK, SL, SY, TJ, TM, TN, TR, TT, TZ, UA, UG, US, UZ, VC, VN, YU, ZA, ZM, ZW.
- (84) Designated States (unless otherwise indicated, for every kind of regional protection available): ARIPO (BW, GH, GM, KE, LS, MW, MZ, NA, SD, SL, SZ, TZ, UG, ZM, ZW), Eurasian (AM, AZ, BY, KG, KZ, MD, RU, TJ, TM), European (AT, BE, BG, CH, CY, CZ, DE, DK, EE, ES, FI, FR, GB, GR, HU, IE, IT, LU, MC, NL, PL, PT, RO, SE, SI,

[Continued on next page]

(54) Title: USE OF METAL TRICARBONYL COMPLEXES AS RADIOTHERAPEUTIC CHEMOTOXIC AGENTS

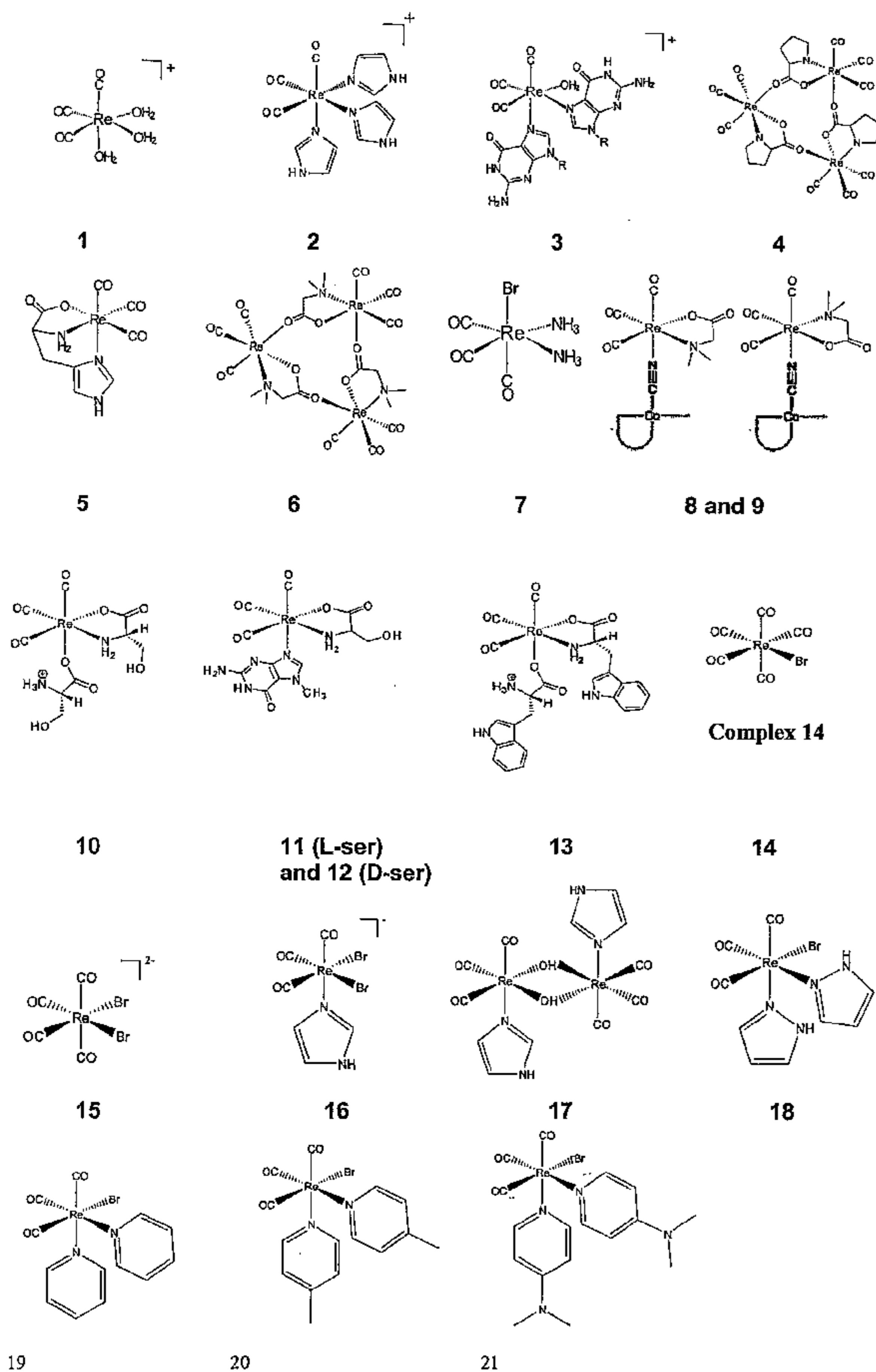

(57) Abstract: The invention relates to the use of metal tricarbonyl compounds of the general formula $[M(CO)_3L_n]^{+}$, wherein M is rhenium or technetium or an isotope thereof and L is a ligand, for the preparation of a medicament for the treatment of cancer that is both radiotherapeutic and chemotoxic when a radioactive metal is used and chemotoxic when cold rhenium or macroscopic amounts of long-lived Tc-99 is used. The medicament is in particular chemotoxic by causing intrastrand linkages in DNA. In a specific embodiment at least one of L is not OH₂. The invention further relates to novel compounds of the general formula $[M(CO)_3X_1X_2X_3]^{+}$ and their use, wherein M is rhenium or technetium or an isotope thereof and at least one of X₁, X₂ and X₃ is a monodentate ligand; or two of X₁, X₂ and X₃ are part of a bidentate ligand and the other one is optionally a monodentate ligand.

WO 2005/039648 A3

WO 2005/039648 A3



SK, TR), OAPI (BF, BJ, CF, CG, CI, CM, GA, GN, GQ,
GW, ML, MR, NE, SN, TD, TG).

(88) Date of publication of the international search report:
24 November 2005

Published:

— *with international search report*

For two-letter codes and other abbreviations, refer to the "Guidance Notes on Codes and Abbreviations" appearing at the beginning of each regular issue of the PCT Gazette.

USE OF METAL TRICARBONYL COMPLEXES
AS RADIOTHERAPEUTIC CHEMOTOXIC AGENTS

The present invention relates to the use of metal
5 tricarbonyl complexes for the preparation of a medicament for
the treatment of cancer. The invention further relates to
novel chemotoxic and optionally radiotherapeutic compounds
for use in the treatment of cancer and in methods of
monitoring the presence of these compounds in the body.

10 It is now generally accepted that the cytotoxicity of
the leading anticancer drug cisplatin is due to the formation
of 1,2-intrastrand adducts between the N7 atoms of two
adjacent guanine residues in DNA. The products of this
interaction are d(GpG)cross-links and less frequently d(ApG).
15 Not only have these adducts been observed both *in vitro* and
in vivo, but clinically inactive compounds fail to form such
cross-links.

Early structure-activity relationship studies
indicated that for any cis-PtA₂X₂ analogue of cisplatin (A₂ is
20 two amines or a bidentate amine ligand and X is an anionic
leaving group) the carrier amine ligand had to have at least
one proton for the drug to retain its anticancer activity.
This observation, along with the realization that d(GpG) can
assume different conformations around the metal core, led to
25 the hypothesis that hydrogen bonding interactions between
bound G ligands and the carrier amine of the drug were
important for the stabilization of the DNA distortion induced
by the intrastrand lesion. It was also demonstrated that the
guanine O6 H-bonding to carrier amine ligand hydrogen is not
30 important for the bases to assume a particular orientation
around the metal center and it was hypothesized that the
small size of the NH group rather than its hydrogen-bonding
ability is important for the anticancer activity of the drug.

One of the major disadvantages of cisplatin are its severe toxic side effects due to nonspecificity of the drug and the relatively large amounts to be administered. The drug is unspecific in its interaction with DNA and virtually any
5 base can be platinated. Furthermore, many malignant tumors develop resistance to the drug. Also the coordination sphere of the metal ion cannot be derivatized with targeting agents as the molecules thus obtained lose their activity. Therefore, much interest remains in synthesizing metal
10 complexes that are capable of binding to DNA bases in a fashion similar to cisplatin but do not present the disadvantages listed above.

Future cancer therapy will *inter alia* consist of a combination of several drugs or several effects which
15 complement each other. The inventors contemplated that such a combination can also consist of radiotherapy and chemotherapy and might bring along important therapeutic advantages to cure cancer. Such therapeutic strategies would be in particular versatile if radio- and chemotoxicity would be
20 based on one single compound. It was, therefore, considered by the inventors that it is desirable to employ compounds that might function mechanistically as cisplatin derivatives, causing intrastrand linkages of DNA by coordination of the metal center to two purine bases, in combination with an
25 inherent radioactivity of the metal center. Such a class of compounds would act to inhibit DNA transcription while delivering a highly localized radiation dose in the target tumor tissues. The molecules may also be precisely localized in the body by well-established imaging techniques, allowing
30 an exact quantification of the amounts of agent in the target tissues.

On the basis of these considerations it is the object of the present invention to provide novel transition-metal complexes which combine both properties.

It was found according to the invention that the
5 $[M(CO)_3]^+$ core (M = Re, Tc) can bind oligonucleotides comprising a GG motif with good stability and can cause similar structural changes in DNA as cisplatin. This was unexpected because the skilled person would expect
10 coordination of this core to DNA bases to result in sterically too crowded complexes to have good stability. It was furthermore found that the $[M(CO)_3]^+$ core surrounded by a proper set of ligands is chemotoxic and when M is a radioactive isotope also radiotoxic.

The invention thus relates to the use of metal
15 tricarbonyl compounds $[M(CO)_3L_3]^+$, wherein M is rhenium or technetium or an isotope thereof and L is a ligand, for the preparation of a chemotoxic and optionally radiotherapeutic medicament for the treatment of cancer. In case cold rhenium or macroscopic amounts of long-lived Tc-99 are used the
20 medicament is chemotoxic. In the case of a radioactive metal the compound is also radiotherapeutic.

The invention relates in particular to the use of tricarbonyl compounds of the general formula $[M(CO)_3L_3]^+$, wherein M is an isotope of rhenium (in particular Re(I)) or
25 technetium (in particular Tc(I)) and L is a ligand for the preparation of a medicament for the treatment of cancer that is both chemotoxic by causing intrastrand linkages in DNA and radiotoxic. In a particular embodiment at least one of L is not OH_2 .

30 In a particular embodiment of the use of the invention the tricarbonyl compounds are of the general formula:

4

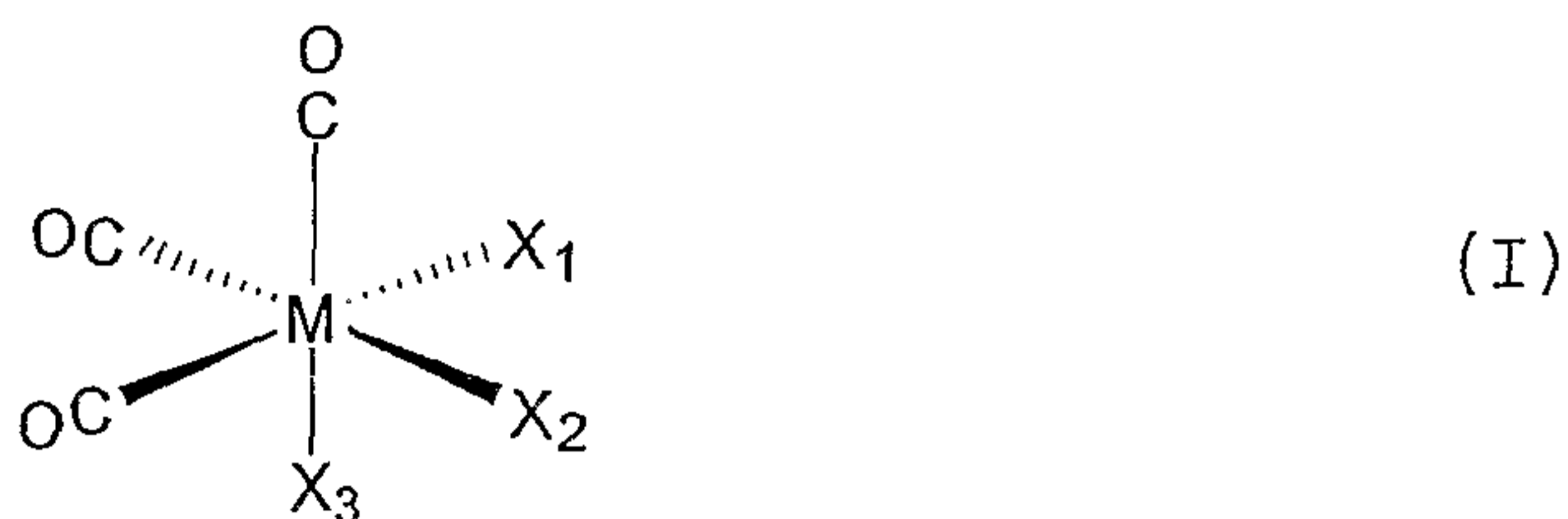

5

wherein

M is rhenium (Re(I)) or technetium (Tc(I)) or an isotope thereof;

at least one of X_1 , X_2 and X_3 is a monodentate ligand; or
 10 two of X_1 , X_2 and X_3 are part of a bidentate ligand and the other one is optionally a monodentate ligand.

The invention also relates to novel compounds of formula I as such. The following specification about the compounds thus relates to the compounds *per se*, as well as to
 15 the compounds of which the use is claimed.

The ligands serve two characteristics. First, they improve the rate and stability of binding to DNA. This concerns in particular the monodentate ligands. The compounds of the invention may thus have one monodentate (for example
 20 complex 16), two monodentate (e.g. complex 18) or three monodentate ligands (e.g. complex 2). The presence of at least two monodentate ligands serves also to protect the $[M(CO)_3]^+$ core from interacting with serum proteins. Such compounds are thus pro-drugs. In the intracellular space,
 25 these ligands are released and the drug is formed. A bidentate ligand serves exclusively protection. Complexes like 6, 10-13 are novel and are pro-drugs. The bidentate ligands are released and the compound becomes active in cross-linking DNA. Compounds comprising exclusively mono- or
 30 bidentate ligands are unspecific (as is cisplatin) but linking a targeting biomolecule to either of them makes them target specific.

The monodentate ligands can be the same or different and can be selected from the group consisting of halogens, CO, aromatic heterocycles, thioethers, isocyanides.

Aromatic heterocycles are five- or six-membered aromatic rings in which one or more of the members of the ring is an element other than C, e.g. N, S, O, P and mutual combinations thereof.

Within this group the halogens are selected from the group consisting of bromo, iodo, fluoro, chloro. Examples of suitable aromatic heterocycles are selected from the group consisting of pyridine, pyrimidine, pyrazine, imidazole, pyrazole, triazole, tetrazole, thiazole, oxazole and organic molecules having one of this group as an integral part. Suitable examples of thioethers are selected from the group consisting of linear substituted dialkyl-thioethers or cyclic thioethers such as tetrahydrothiophen and other organic molecules containing a thioether functionality as an integral part of it, and examples of suitable isocyanides are selected from organic molecules comprising a terminal -NC group coupled to an alkyl chain optionally comprising a terminal functionality such as a -COOH, -NH₂, -X, -SH, -OH group. Each one of the halogens can be combined with the same one or two halogens or with each one of the aromatic heterocycles and/or with each one of the thioethers and/or each one of the isocyanides.

Each one of the monodentate ligands can be part of a larger molecule. For example, imidazole can be the side chain of a histidine in a peptide. The peptide in turn can be a targeting peptide.

When the compounds of the invention comprise a bidentate ligand it can be selected from amino acids and dicarboxylates.

In a particular embodiment the bidentate ligand is an anionic amino acid. The advantage thereof is that amino acids are cleaved from the Re(I)- or Tc(I)-center at lower pH as encountered e.g. in cancer cells and lysosomes, thus, releasing the active part of the complex as a drug. Suitably, the amino acid is a non-natural α - or β -amino acid. In a particularly useful embodiment the non-natural amino acid is N,N-dimethyl glycine. While not wishing to be bound by theory, it is believed that since the two methyl groups are sterically demanding and the ligand is weaker bound to Re(I) or Tc(I) than unmethylated glycine, this entails easier release at lower pH.

In a specific embodiment a compound of the invention is a complex selected from complexes 6, 10, 11, 12, 13 and 18 as depicted in **Figure 16**.

Compounds of general formula I above are considered to have the required chemotoxic activity if they meet the following criteria. If at least two of the ligands in a compound as shown in formula I have been exchanged by guanine or guanosine after 3 days at 37°C with guanine or guanosine being present in a slight excess over rhenium or technetium, the starting complex is considered to have the claimed utility for cancer treatment.

The compounds of the invention can be derivatized in the sense that X_1 and/or X_2 and/or X_3 are coupled to a targeting moiety. Targeting moieties are known in the art and the skilled person is very well capable of selecting a targeting moiety that meets his needs. Suitable examples of targeting moieties are bombesin, neurotensin, somatostatin, glucosamine, nucleosides, nuclear localizing sequence peptides (NLS-peptides) oligonucleotides, nucleus targeting molecules such as anthracyclines, acridines and other intercalators, as well as derivatives or analogues thereof.

The compounds herein described and used in accordance with the invention are based on mono-nuclear octahedral complexes of metal ions which combine the inherent radioactivity of the metal center with the mechanistic properties of cisplatin. This is unexpected since octahedral complexes are in general believed to be sterically too crowded to interact with DNA in a comparable way. Despite that, the present inventors have demonstrated that two nucleo-purines bind the Re(I) center in cis arrangement and do so at a rate comparable to that of platinum compounds leading to a chemotoxic activity comparable to cisplatin.

X-ray structures (see **Example 4**) of technetium and rhenium complexes bound specifically to two guanines via the N7 atoms together with kinetic and thermodynamic data of the interaction of $[M(CO)_3(H_2O)_3]^+$ (wherein M = Re, Tc and isotopes thereof) with G and 2dG experimentally prove the intended structural properties. Correspondingly, comparison of these data with those of $[Pt(NH_3)_2(H_2O)_2]^{2+}$, shows that **1** and **2** are potential chemotoxic agents affecting DNA like cisplatin. The radiotoxic mode of action of Re-186/188 is well established. As in the Pt case, two guanine ligands can adopt several conformations in an octahedral $[(CO)_3Re(I)(purine)_2X]$ complex (X = H₂O, Br).

It is also shown by the present inventors that rhenium complexes with at least two available coordination sites influence the tertiary structure of Φ X174 DNA by altering the electrophoretic mobility of the open circular and the supercoiled form of plasmid DNA. The $[Re(I)(CO)_3]^+$ moiety displays a principally similar reactivity pattern with plasmid DNA as e.g. cisplatin. It binds selectively to two free guanines, implying a possible interaction with adjacent guanines in DNA as well. The induced changes involve covalent

binding to two bases rather than simple electrostatic interaction.

Furthermore, it was shown now that at a 200 μM concentration rhenium complexes are capable of inhibiting proliferation of certain types of human cancer cell lines.

The improvements of the above mentioned compounds over the current state of the art are the following. Mono-nuclear octahedral $^{186}\text{Re}(\text{I})$ or $^{188}\text{Re}(\text{I})$ complexes can combine the radioactivity of the metal center with the ability of intra- or interstrand linking in DNA. Such a class of compounds can inhibit DNA transcription while delivering a highly localized radiation dose in the target tumor tissues. This type of complex can thus act as chemotoxic radiopharmaceuticals suitable for cancer therapy. Mono-nuclear octahedral $^{99\text{m}}\text{Tc}(\text{I})$ complexes can be used as diagnostic analogs of the above $^{186}\text{Re}(\text{I})$ or $^{188}\text{Re}(\text{I})$ compounds.

Compounds of the invention can easily be combined with vectors (i.e. polypeptides) that allow targeting, active uptake and degradation in the cytoplasm. A targeting biomolecule might be attached to X_1 or X_2 or X_3 , or X_2/X_3 might be part of a larger structure, e.g. the imidazole side chain of histidine in a peptide or a GG motif in an oligonucleotide. In the latter case, the GG motif protects the $\text{Re}(\text{I})$ active core but is released after oligonucleotide degradation in the cytoplasm.

Furthermore, non-radioactive substances with a structure identical to the radioactive ones can be added (tracer addition) to improve the therapeutic efficacy while the analogous radioactive compounds allow monitoring biodistribution. This is not possible with any current, metal based or organic chemotoxic agent in clinical use.

As it is well known that by combining radiotherapy and chemotherapy, important therapeutic advantages can be

obtained to cure cancer, the above mentioned molecules are the first example of a molecular species comprising both properties (i.e. radioactivity and chemotoxicity) in one molecule.

5 Contrary to most other strategies which result in the design of Re(I) based compounds exclusively suited for radiotherapeutic purposes where the metal core is prevented from interacting further at the target site, the compounds of the invention can, upon delivery, actively participate in the
10 biochemistry at the desired target tumor site.

The invention further allows for systematic drug discovery. By varying the substituents X_1 , X_2 and X_3 at different positions various types of compounds can be obtained without undue burden. As a consequence, the
15 molecules may be fine-tuned towards their interaction with DNA bases. Of course the decisive test is if such compounds meet the activity criteria.

According to a further aspect thereof, the invention relates to pro-drugs. In such compounds the ligands are
20 released from the pro-drug to generate the active form of the drug e.g. when the pH decreases as in cancer cells. Suitable examples of pro-drugs of the invention are compounds of formula I wherein at least two of X_1 , X_2 and X_3 are a monodentate ligand or part of a bidentate ligand as defined
25 above. Furthermore, the pro-drug can be coupled to targeting agents or metabolically active substances which might increase the therapeutic index. The ligands on the pro-drugs can protect the $[M(CO)_3]^+$ core and can dissociate and release the "active form" of the drug in cancer cells.

30 In the case of pro-drugs, in the compounds of formula I X_1 represents, for example, a monodentate ligand whereas X_2 and X_3 are monodentate ligands or form together a bidentate chelator. The definitions of X_1 , X_2 and X_3 are as described

above. X_2X_3 represent the protecting group ligand(s) forming the pro-drug which are released in the cell to form the drug. X_1 influences the efficacy of DNA binding and the release of the pro-drug.

5 The different aspects of the invention are explained in **Figure 1**. In this figure compound I reacts with isolated G or DNA to form intra- or interstrand cross-links (**Examples 4, 5 and 7**), compound II reacts with G or DNA to form intra- or interstrand cross-links (**Example 3 and 13**). Compounds I and 10 II are considered as drugs since they also conjugate to serum proteins and can therefore not immediately be taken up by the cell, thus, they are inactive, compound III is an intermediate. It can directly react with DNA (drug) after being taken up in the cell. Since it does not strongly 15 interact with serum proteins, it can be considered as a pro-drug (**Example 13, complex 8**) or it can lose one ligand, become compound II and act as a drug. The real pro-drugs are IV and V. Both do not react with serum proteins (hence they are pro-drugs) but could in principle directly react with 20 DNA. More likely and shown in **Example 8** is the loss of ligands X_2 and X_3 to form compound II which is then the drug. Pathways 1- 5 are drugs, pathways 6-8 are pro-drugs.

 In this application the words "chemotoxic" and "cytotoxic" are used interchangeably. A compound is for 25 example in itself chemotoxic but it has a cytotoxic effect on a cell. Cytotoxicity testing thus relates to the effect a compound will have on a cell, whereas chemotoxicity is an inherent feature of a compound. Furthermore, the words "compound" and "complex" are used interchangeably.

30 The present invention will be further elucidated in the Examples that follow and that are in no way intended to limit the invention. Reference is made to the following figures:

Figure 1 shows a general scheme for the compounds and reaction pathways of the compounds claimed.

Figure 2 shows the activity test for compounds of the invention.

5 Figure 3 shows the HPLC-MS chromatograph of Example 3.

Figure 4 shows the X-ray crystal structures of $[\text{Re}(9\text{-MeG})_2(\text{H}_2\text{O})(\text{CO})_3](\text{ClO}_4)$ and of $[\text{Re}(9\text{-MeG})_2(\text{CH}_3\text{OH})(\text{CO})_3](\text{ClO}_4)$.

Figure 5A shows the aromatic region (7.0-9.0 ppm) at the end of the reaction of 1 with $d(\text{CpGpG})$.

10 Figure 5B shows the pH dependence study confirming that the bis $[\text{Re}(\text{CO})_3d(\text{CpGpG})(\text{H}_2\text{O})]^-$ adduct binds to N7 atoms of guanine residues.

Figure 6A shows the action of cisplatin on $\Phi\text{X} 174$ plasmid DNA. Lines 4-8 show the increased amount of scrambling as a consequence of cis-GG binding of cisplatin.

Figure 6B shows the interaction of complex 1 on $\Phi\text{X}174$ plasmid DNA at conditions as described above. The result is similar to the one observed with cisplatin in Figure 6A.

Figure 6C shows the interaction of the cationic Complex 2 with $\Phi\text{X}174$ plasmid DNA. No scrambling of DNA is observed.

Figure 7, lanes 2-7 show that the complexes with two labile cis ligands induce scrambling in $\Phi\text{X}174$ plasmid DNA, whereas in lanes 8-14 no structural change is observed.

25 Figure 8A shows the interaction of $\Phi\text{X} 174$ plasmid DNA with complexes 1 and 6. Obviously, complex 6 causes DNA scrambling which is indicative for GG cross-links, comparable to cisplatin.

Figure 8B shows the structure of the pro-drug 6 and the resulting drug 1 and the X-ray structure of the pro-drug.

Figure 8C shows the schematized conversion of the pro-drug 6 to the active drug.

Figure 9A shows incubation of Φ X174 plasmid DNA with complexes 1 and 7 according to the procedure described in **Example 6**.

Figure 9B shows same samples after incubation with histidine to release the metal complexes and to reconstitute the original shape of Φ X174 plasmid DNA.

Figure 10 shows a typical XTT cell proliferation assay for the determination of the cytotoxicity of the rhenium complexes as used in **Examples 10-13**.

Figure 11 is a graphic representation of the cytotoxicity (% of cell survival) exhibited by complexes 1, 3, 4 and 5 toward MDA-MB-4355 Breast Cancer Cells (ATCC #TB129).

Figure 12 is a graphic representation of the cytotoxicity (% of cell survival) exhibited by complexes 1, 3, 4 and 5 toward OVMZ-6-WT Ovarian Cancer Cells (obtainable from Deutsche Sammlung von Mikroorganismen und Zelllinien DSMZ GmbH).

Figure 13 is a graphic representation of the cytotoxicity (% of cell survival) exhibited by complexes 1, 3, 4 and 5 toward HSC45-M2 Gastric Cancer Cells (Deutsche Sammlung von Mikroorganismen und Zelllinien DSMZ GmbH).

Figure 14A is a graphic representation of the cytotoxicity (% of cell survival) exhibited by complexes 1 to 13 toward B16F1 mouse melanoma cells (Deutsche Sammlung von Mikroorganismen und Zelllinien DSMZ GmbH).

Figure 14B is a graphic representation of the cytotoxicity (% of cell survival) exhibited by complexes 1, 2 and 14 to 21 toward B16F1 mouse melanoma cells (ATCC) compared to cisplatin.

Figure 15 shows the coupling of the targeting moiety acridine to N-ethylamino-imidazole.

Figure 16 is an overview of compounds of the invention.

EXAMPLES

5 **EXAMPLE 1**

Synthesis of compounds of the invention with a monodentate ligand

1. *General method*

The compounds of the invention with monodentate
10 ligands generally can be synthesized by adding one equivalent of the ligand to a solution of **1**.

2. *Specific example ([Et₄N][ReBr₂(Im)(CO)₃] (**16**))*

As an example the synthetic procedure for **16** is given
15 below: (Et₄N)₂[ReBr₃(CO)₃] (**1**, 96 mg, 0.12 mmol) was dissolved in CH₂Cl₂ (5 mL). Imidazole (Im, 8 mg, 0.12 mmol) was added and the mixture was stirred at room temperature. After 30 min a white solid appeared. This was filtered and dried under vacuum. Yield.: 45 mg, 60%.

20 Elemental analysis calculated for **16**, C₁₄H₂₄N₃O₃Br₂Re (628,38): C, 26.75; H, 3.82; N, 6.68, found: C, 26.83; H, 3.71; N, 6.62.

EXAMPLE 2

25 Synthesis of compounds of the invention with a bidentate ligand

1. *General method*

The compounds of the invention with bidentate ligands
generally can be synthesized by adding one or more
30 equivalents of the ligand to a solution of **1**.

2. *Specific example ([Re(L-Ser)₂(CO)₃] (**10**))*

As an example the synthetic procedure for **10** is given below: $(\text{Et}_4\text{N})_2[\text{ReBr}_3(\text{CO})_3]$ (100 mg, 0.13 mmol) was dissolved in a methanol/water mixture (9:1, 5 mL). L-serine (48 mg, 0.46 mmol) was added and the mixture was stirred for 3 h at 50°C under a slight N_2 pressure. The reaction was monitored by HPLC and it was stopped when no further change could be observed (3h). The solution was allowed to equilibrate to room temperature and purified by HPLC. A white solid was obtained. Yield : 23 mg, 37%. Crystals suitable for x-ray analysis were obtained by slow evaporation of H_2O .

Elemental analysis calculated for **10**, $\text{C}_9\text{H}_{13}\text{N}_2\text{O}_9\text{Re}$ (479,41): C, 22.55; H, 2.73; N, 5.84, found: C, 23.17; H, 3.20; N, 5.47.

15 **EXAMPLE 3**

$[\text{M}(\text{CO})_3]^+$ binding to guanine

In order to test whether a metal tricarbonyl can bind to purine bases the following test was performed. A 1mM aqueous (or $\text{H}_2\text{O}/\text{CH}_3\text{OH}$ mixture) solution of compounds of general formula I incubated at 37°C for 3 days with a 6-fold excess of guanine shows more than 50% binding of one or two guanines to the metal center (**Figure 2**).

In water, (37°C) **16** reacts with 9-MeG stepwise. In our HPLC gradient complex **16** has a retention time (rt) of 13.9 min. After 1h a second peak is observed with rt of 17.4 min. HPLC-MS chromatography indicates that this species is $[\text{Re}(\text{Im})(9\text{-MeG})(\text{H}_2\text{O})(\text{CO})_3]$ (**16a**). After a further 12h a third and a fourth peak appear at 17.0 and 16.2 min which were identified by HPLC-MS chromatography as $[\text{Re}(9\text{-MeG})_2(\text{H}_2\text{O})(\text{CO})_3]^+$ (**3**) and $[\text{Re}(9\text{-MeG})(\text{H}_2\text{O})_2(\text{CO})_3]^+$ (**3a**) respectively. The relative height of the peaks, with species **3** and **3a** increasing in concentration, gave the only other change observed after a further 12h period of incubation (**Figure 3**).

This example shows, that guanines can substitute imidazole as a protecting ligand in compounds of general formula I. Compound 3 is a model for the structural feature of the $[M(CO)_3]^+$ moiety after cross-linking guanines in DNA.

5

EXAMPLE 4

Formation of a $[M(CO)_3]^+$ ($M = {}^{99}\text{Tc(I)}, \text{Re(I)}$) bis guanine adduct $[\text{Re}(9\text{-MeG})_2(\text{H}_2\text{O})(\text{CO})_3](\text{ClO}_4)$ (3)

$(\text{Et}_4\text{N})_2[\text{ReBr}_3(\text{CO})_3]$ (30 mg, 0.04 mmol) was dissolved in hot ($\sim 40^\circ\text{C}$) water (3 mL). AgClO_4 (28 mg, 0.14 mmol) was added and the mixture was stirred for 3 h after which time AgBr was filtered off. 9-methylguanine (16.5 mg, 0.1 mmol) was added and the mixture was heated to 50°C under a slight N_2 pressure. The colorless solution turned light yellow within minutes. The reaction was monitored by HPLC and it was stopped after 3.5 hr when no further change could be observed. The solution mixture was allowed to equilibrate to room temperature, concentrated and then purified on a short C18 column.

To the methanol fraction containing the purified complex 3% H_2O (v/v) was added. Pentane was allowed to diffuse into the solution depositing x-ray quality crystals. Yield : quantitative.

Elemental analysis calculated for 3, $\text{C}_{15}\text{H}_{16}\text{ClN}_{10}\text{O}_{10}\text{Re}$ (718.01): C, 25.09; H, 2.25; N, 19.51, found: C, 25.34; H, 2.70; N, 19.45.

The X-ray crystal structure is shown in Figure 4.

EXAMPLE 5

Interaction of $[M(CO)_3]^+$ with oligonucleotides

Figure 5A shows the ^1H NMR spectrum of the reaction of $[\text{Re}(\text{H}_2\text{O})_3(\text{CO})_3]^+$ (1) with 1 eq. of $d(\text{CpGpG})$ in D_2O . At 37°C the addition of 1 to a solution of $d(\text{CpGpG})$ causes the disappearance in the spectrum of the resonances due to the H8

signals of free d(CpGpG) and the appearance of a new set of sharp well separated peaks of the non equivalent H8 protons.

Figure 5A shows the aromatic region (7.0-9.0 ppm) at the end of the reaction of **1** with d(CpGpG) (1h incubation).

5 The two guanine bases bind to Re(I) through N7, a fact corroborated by the pH independence of the H8 resonances at pH values near 2 (**Figure 5B**). In fact all chemical shifts of the H8 are unaffected by lowering the pH below 4, contrary to what is expected for a free guanine N7.

10

EXAMPLE 6

Interaction of complexes 1 and 2 with Φ X 174 plasmid DNA

Φ X174 plasmids were purchased from Promega and used without further purification. Φ X174 RF plasmid DNA (0.1 mg) 15 was mixed with the corresponding rhenium complexes in H₂O at [complex]/[bp] 0.018-1.8/1. The mixtures were incubated in water at 37°C for 22 h in the dark before analyzing by gel electrophoresis. The pH of the mixtures remained constant at \approx 7 in all cases. Experiments performed in 1 mM or 10 mM NaClO₄ 20 showed no significant difference in the binding of **1** to Φ X174 RF plasmid DNA.

DNA binding was examined by gel electrophoretic mobility shift assays through 9 cm 0.75% agarose slab gels with TAE running buffer. The gels were run at RT, with 25 voltages varying between 50 and 75 V. Running time depended upon the voltage and were usually between 1.5-2 h. The resultant gels were stained with ethidium bromide in the buffer at a concentration of \approx 0.3 μ g/mL. Bands were visualized by software UV transillumination equipped with a 30 digital camera.

Figure 6A shows the action of cisplatin on Φ X 174 plasmid DNA. Lines 4-8 show the increased amount of scrambling as a consequence of cis-GG binding of cisplatin.

Figure 6B shows the interaction of complex 1 on Φ X174 plasmid DNA at conditions as described above. The result is similar to the one observed with cisplatin in Figure 6A.

Figure 6C shows the interaction of the cationic Complex 2 with Φ X174 plasmid DNA. No scrambling of DNA is observed.

It follows that $[M(CO)_3]^+$ interacts with Φ X174 plasmid DNA in a fashion similar to cisplatin. It is also shown that the interaction is not due to electrostatic effects.

10

EXAMPLE 7

Two cis labile ligands are required to induce structural changes of Φ X174 plasmid DNA

In this example, Φ X174 plasmid DNA has been incubated with different complexes containing mono- or bidentate ligands. The complexes 1 and 3 comprise cis-labile ligands whereas complexes 4 and 5 are stable towards substitution with two G's.

Figure 7, lanes 2-7 show that the complexes with two labile cis ligands induce scrambling in Φ X174 plasmid DNA, whereas in lanes 8-14 no structural change is observed. If the two cis labile ligands are only slowly released, then the precursor complex can be considered as a prodrug. This behavior is described in Example 8.

25

EXAMPLE 8

Preparation of a pro-drug

A pro-drug containing complex 1 as the effective drug contains two labile ligand in cis arrangement which are slowly released from the Re(I) center. After cleavage of the labile ligands a complex of the composition $[M(X_1)(OH_2)_2(CO)_3]$ is formed which represents the active drug. We describe here

30

the synthesis of such a pro-drug containing N,N-dimethyl-glycine as the cis-labile ligand.

Complex 1 (Et₄N)₂[ReBr₃(CO)₃] (100 mg, 0.13 mmol) was dissolved in a methanol/water mixture (4:1, 10 mL).

5 N,N-dimethylglycine (70 mg, 0.7 mmol) was added and the mixture was stirred for 12 h at 50°C under a slight N₂ pressure. The solution was allowed to equilibrate to room temperature concentrated and purified on a short C18 filter. A white crystalline solid was obtained. Yield : 20 mg, 40%.

10 Crystals suitable for x-ray diffraction were obtained by slow diffusion of ether in a CH₃CN solution of the complex. Elemental analysis calculated for 6, C₂₁H₂₄N₃O₁₅Re₃ (1117.05): C, 22.58; H, 2.17; N, 3.76, found: C, 23.19; H, 2.78; N, 3.84. ¹H NMR (500 MHz, DMSO-d₆, d/ppm): 4.18 (s, 2H), 3.46 (s, 3H),
15 3.15 (s, 3H).

FT-IR for 6 (KBr, ν/cm⁻¹): (C=O) 2022 (s), (C=O) 1911 (b), (C=O) 1890 (s), (C=O) 1866 (s). ESI-MS for 6 (ESI+, 40V, m/z): 1117.0 ([M]⁺). HPLC R_t for 6 (HPLC, Gradient 1, min): 15.7.

20 **Figure 8A** shows the interaction of ΦX174 plasmid DNA with complexes 1 and 6. Obviously, complex 6 causes DNA scrambling which is indicative for GG cross-links, comparable to cisplatin.

Figure 8B shows the structure of the pro-drug 6 and
25 the resulting drug 1 and the X-ray structure of the pro-drug.

The interaction of complex 6 with guanine has been studied according to the test outlined in **Example 4**. NMR and HPLC experiments clearly show, that the bidentate ligand N,N-dimethyl-glycine is cleaved and replaced with two
30 guanines, the same that happens in ΦX174 plasmid DNA. **Figure 8C** shows the schematized conversion of the pro-drug 6 to the active drug.

EXAMPLE 9Stability of the $[M(CO)_3]^+$ Φ X174 plasmid DNA adduct

As outlined in **Example 6**, complexes with cis-labile ligands can bind to Φ X174 plasmid DNA, presumably through GG
5 inter- or intrastrand cross-links. In case of cisplatin binding to DNA, this interaction is irreversible. *In vitro* studies with the complexes **1** and **7** have been performed to assess this stability for two examples of compounds claimed inhere.

10 Complexes **1** and **7** were incubated with Φ X174 plasmid DNA as described in **Example 6**. Subsequently, the plasmid was challenged with histidine to cleave the complexes from Φ X174 plasmid DNA. Although a 100-fold excess of histidine was employed, no release could be observed, i.e. the structural
15 changes in Φ X174 plasmid DNA could not be reversed. The gel electrophoresis traces after 22h are shown in **Figure 9A**.

Figure 9A shows incubation of Φ X174 plasmid DNA with complexes **1** and **7** according to the procedure described in **Example 6**. **Figure 9B** shows same samples after incubation with
20 histidine to release the metal complexes and to reconstitute the original shape of Φ X174 plasmid DNA.

EXAMPLE 10Cytotoxicity Procedure

25 In a typical experiment (see **Figure 10**) an average of 2000 cells were grown in microtiter plates (tissue culture grade, 96 wells, flat bottom) in a final volume of 100 μ L culture medium per well in a humidified atmosphere (37°C, >6.5% CO₂). After 24 h the rhenium complex was added to the
30 wells (final concentrations 200 μ M based on Re) and the cells were grown for further 24 h under a humidified atmosphere. After the incubation period 50 μ L of the XTT labeling mixture were added to each well. The plates were incubated again for

4 h. After the this final incubation period the spectrophotometrical absorbance (optical density OD) of each well was measured at 450 nm.

Control experiments were performed as described above without the addition of the rhenium compounds. Blanks were obtained by adding 50 μ L of H₂O instead of the XTT labeling mixture. Experiments were done in double and the results represent the average.

The % of cell survival was calculated base on the relative OD of the samples. Maximum control OD was set to 100% cell survival.

EXAMPLE 11

Cytotoxicity of [Re(I)(CO)₃]⁺ complexes (200 μ M) towards MDA-MB-4355 Breast Cancer cell line

Figure 11 shows a graphic representation of the cytotoxicity (% of cell survival) exhibited by complexes 1, 3, 4 and 5 toward MDA-MB-4355 Breast Cancer Cells. The results clearly indicate that compounds 1, 3 and 4 inhibit cell proliferation. Complex 5 is stable under the conditions indicated in Example 3 and does not show cytotoxicity towards this breast cancer cell line.

EXAMPLE 12

Cytotoxicity of [Re(I)(CO)₃]⁺ complexes (200 μ M) towards OVMZ-6-WT Ovarian Cancer cell line

The procedure is as described in Example 10 and Figure 10. Only the cancer cell line varies.

Figure 12 shows a graphic representation of the cytotoxicity (i.e. % of cell survival) exhibited by complexes 1, 3, 4 and 5 toward OVMZ-6-WT Ovarian Cancer Cells. The results clearly indicate that compound 1 inhibits cell proliferation in this cancer cell line.

EXAMPLE 13Cytotoxicity of [Re(I)(CO)₃]⁺ complexes (200 μM) towards HSC45-M2 Gastric Cancer cell line

The procedure is as described in **Example 10** and **Figure 10**. Only the cancer cell line varies.

Figure 13 shows a graphic representation of the cytotoxicity (i.e. % of cell survival) exhibited by complexes **1, 3, 4** and **5** toward HSC45-M2 Gastric Cancer Cells. The results clearly indicate that compound **5** inhibits cell proliferation in this cancer cell line.

EXAMPLE 14Cytotoxicity of different rhenium complexes towards B16 F1 mouse melanoma cells

The procedure is as described in **Example 10** and **Figure 10**. Only the cancer cell line varies.

Figure 14A shows a graphic representation of the cytotoxicity (i.e. % of cell survival) exhibited by complexes **1** to **13** toward B16 F1 mouse melanoma cells. The results clearly indicate that compounds **1** and **2** strongly inhibit cell proliferation. Due to poor water solubility the concentration of compounds **4, 5, 6** and **11** to **13** is lower than 200 mM. Consequently the above-mentioned compounds might show higher cytotoxicity at 200 mM.

Figure 14B shows a graphic representation of the cytotoxicity (i.e. % of cell survival) exhibited by complexes **1, 2** and **14** to **21** toward B16 F1 mouse melanoma cells. The results clearly indicate that compounds **1, 2** and **14** to **18** inhibit cell proliferation to an extent comparable to cisplatin.

EXAMPLE 15Coupling of the compounds of the invention to a targeting moiety

In this example, the targeting moiety represents
5 acridine (A), a non-receptor binding but nucleus targeting
organic molecule. Acridine has been derivatized with an
isocyanide and an imidazole group for binding to the $[M(CO)_3]^+$
moiety. The basic and active structures are those of
complexes **16** and **18**, both of which have been shown to
10 crosslink Φ X174 plasmid DNA. The general reaction scheme for
the preparation of the nucleus targeting agents is given in
Figure 15.

Compound A has been coupled to N-ethylamino-imidazole
by standard coupling techniques. A was dissolved in THF and
15 activated with dicyclohexylcarbodiimide (DCC) and
N-hydroxysuccinimide. After activation was complete, 0.9 eq.
of the imidazole derivative was added and the mixture stirred
for 12 h at RT. HPLC showed quantitative conversion of A \rightarrow B.
The compound was used without further purification.

20 Compound A was activated as described above and mixed
with a 50-fold excess of 1,2-diamino-ethane in THF. The
solution was allowed to stir overnight. The solvent was
removed *in vacuo* and the residue washed several times with
saturated $NaHCO_3$. The residue was dissolved in methanol and
25 purified by column chromatography (silica gel, MeOH/ CH_2Cl_2 1/3
v/v). Compound C was then mixed with isocyano-acetic
acid-ethylester and reacted for 48h. After this time C
converted quantitatively to D. The reaction mixture was
purified by column chromatography (silica gel, CH_2Cl_2 /hexane
30 2/1).

One equivalent of compound D is now reacted with **1** to
yield a compound $[Re(D)Br_2(CO)_3]^-$, a composition according to
formula I.

EXAMPLE 16Monitoring the biodistribution of the compounds of the invention

The complexes of general formula I are synthesized
5 with $^{99m}\text{Tc}(\text{I})$ following the same procedures as outlined for
rhenium. The starting complex $\mathbf{1} (^{99m}\text{Tc}(\text{I}))$ is prepared from the
Isolink Kit or according to a published procedure (Alberto et
al. J. Am. Chem. Soc. 1999, 121(25), 6076-6077). The "cold"
cytotoxic rhenium complexes are mixed with the "hot"
10 radiotoxic $^{99m}\text{Tc}(\text{I})$ or $^{188/186}\text{Re}(\text{I})$ complexes. Since these
complexes with either isotope of Tc(I) or Re(I) are analogues
to each other, imaging with standard techniques SPECT cameras
allows to follow where the compounds are accumulating.

The embodiments of the present invention for which an exclusive property or privilege is claimed are defined as follows:

1. A metal tricarbonyl compound selected from the group consisting of the compounds as depicted herein below:

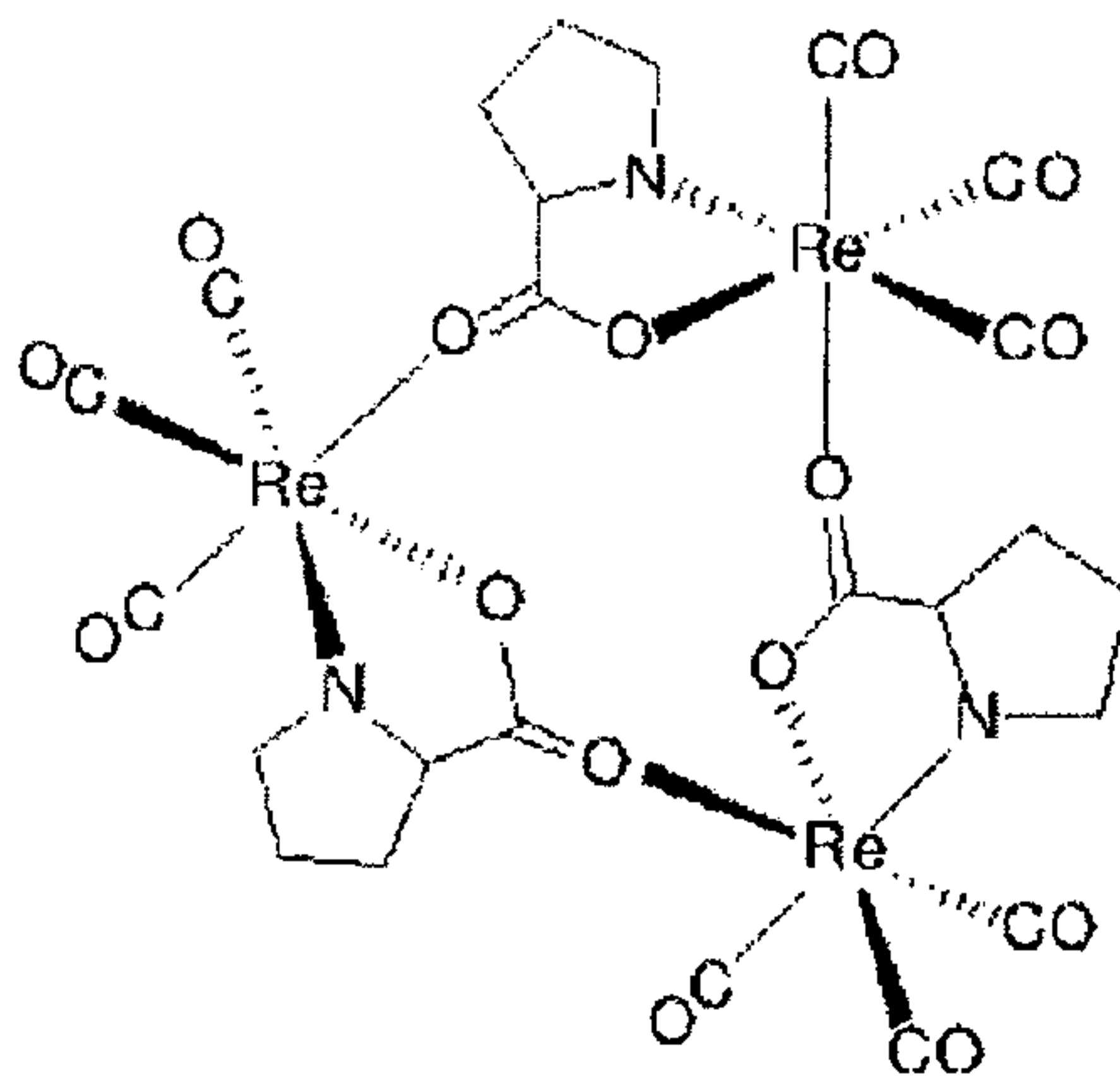

4

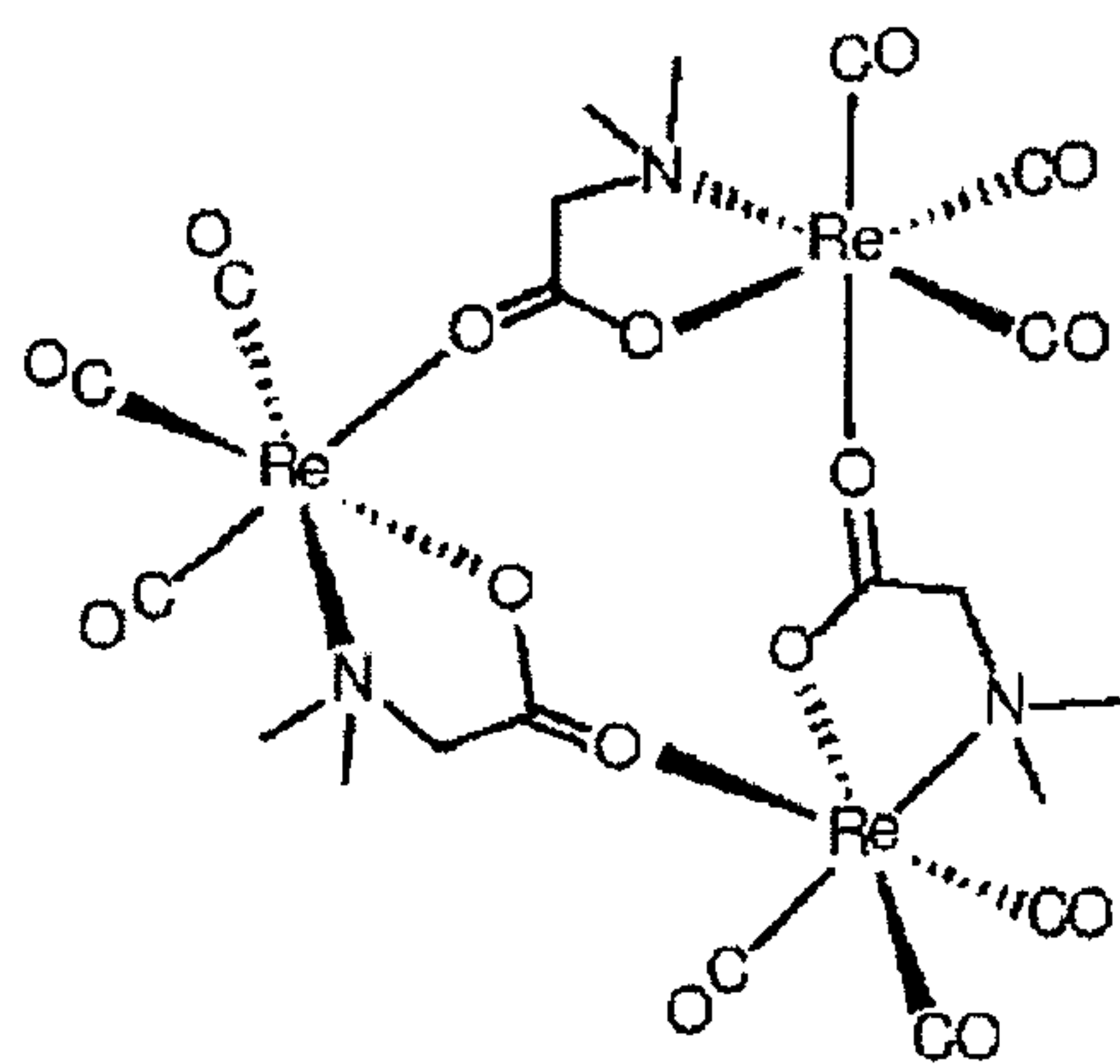

6

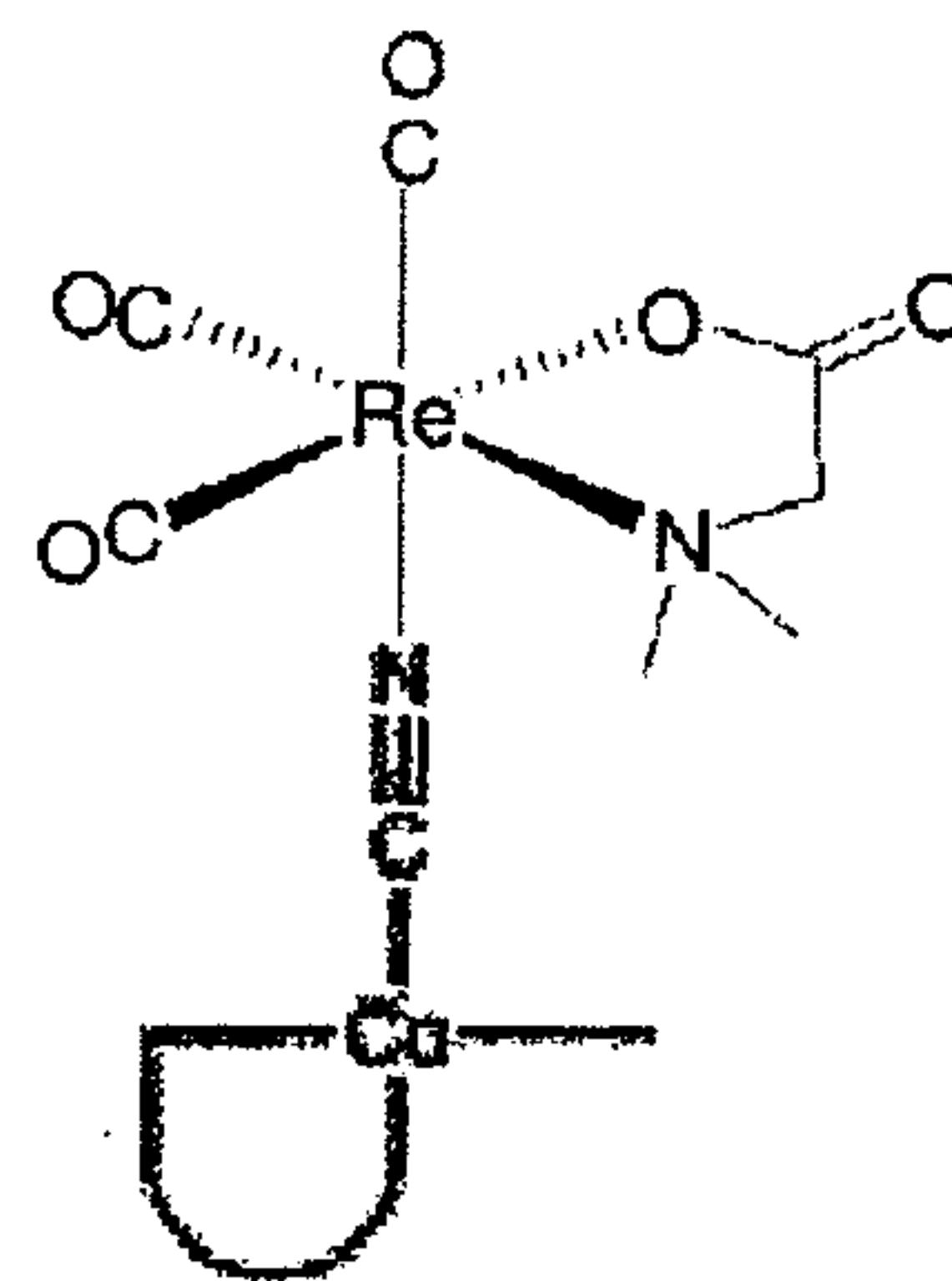

8

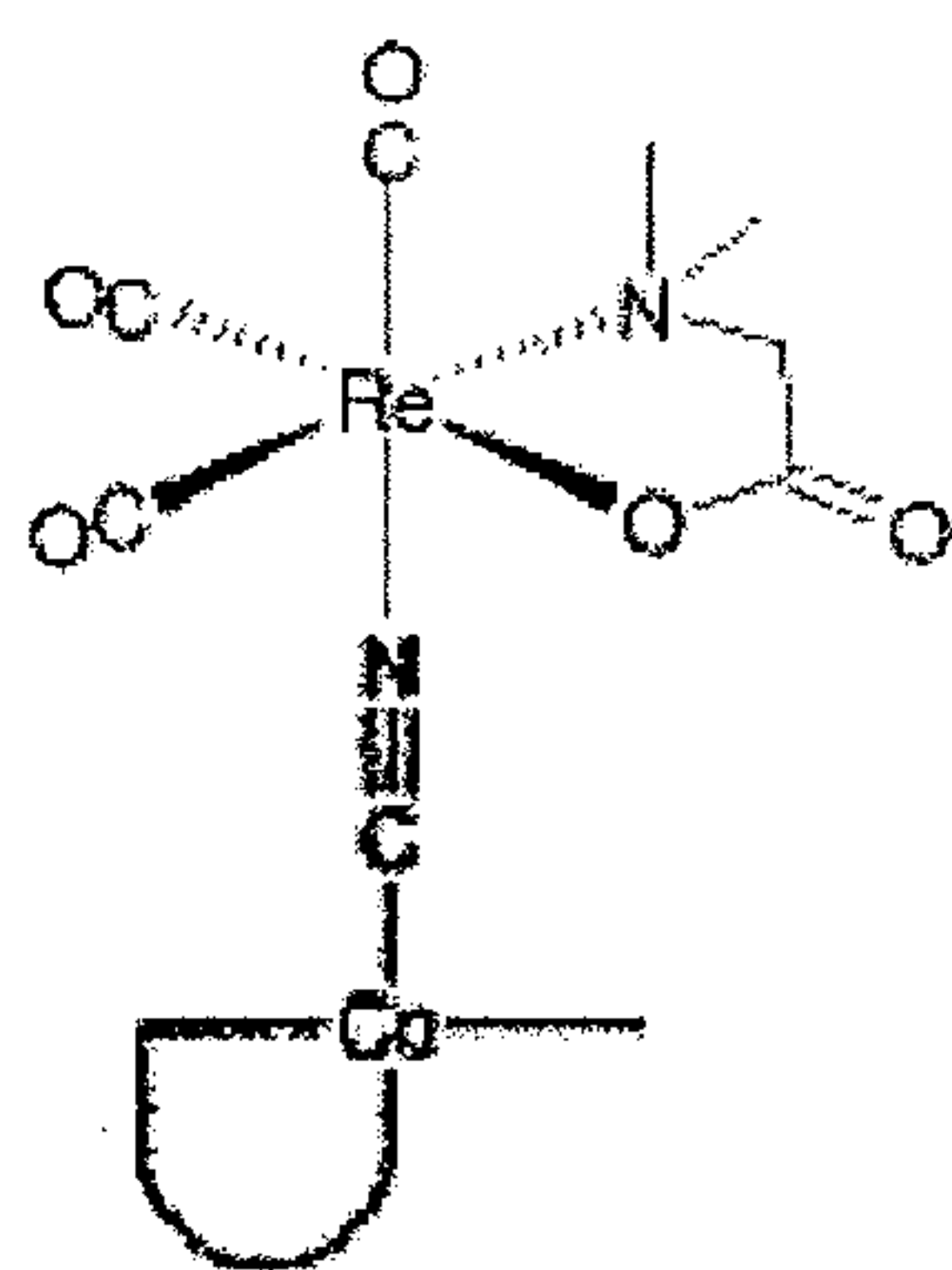

9

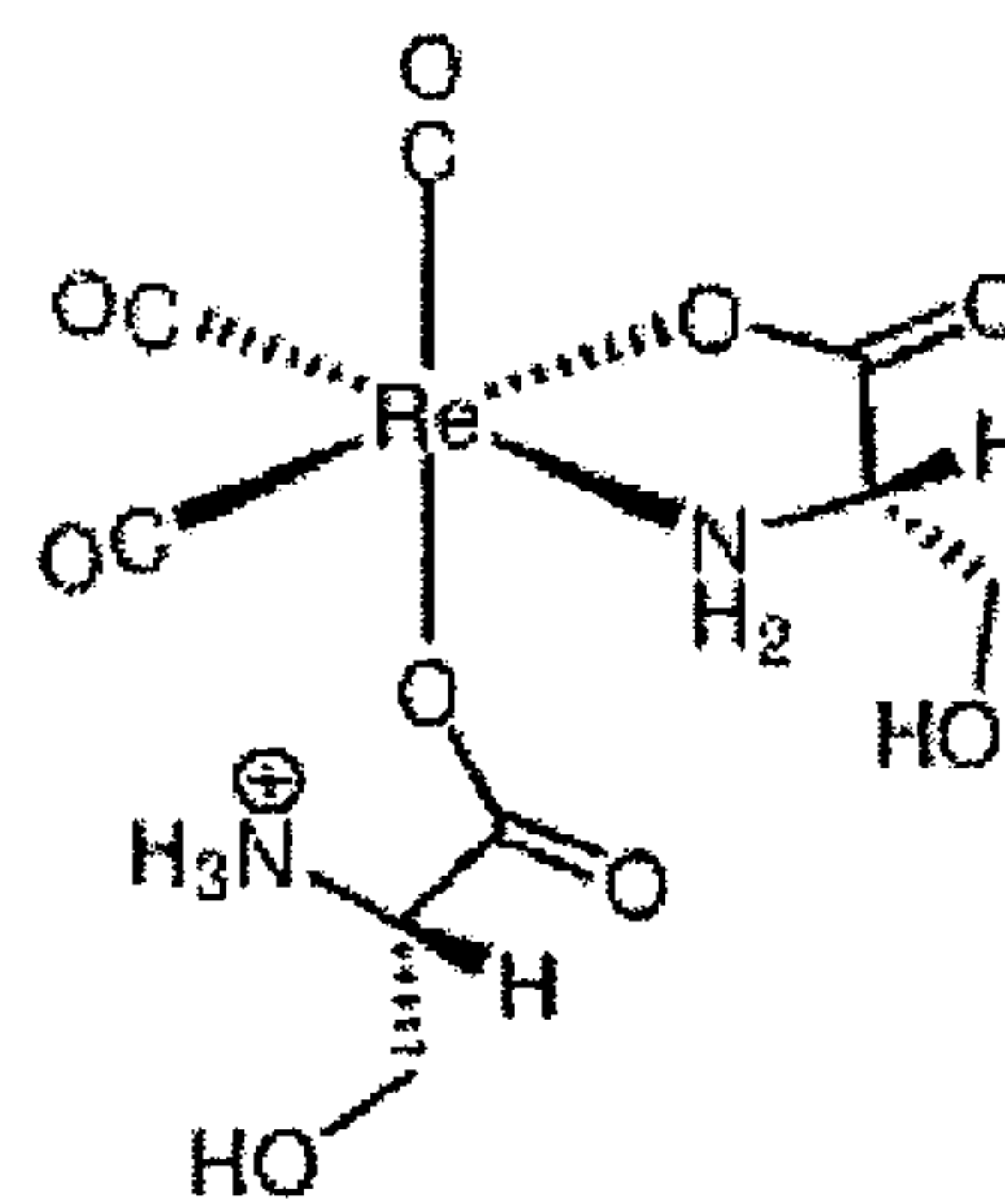

10

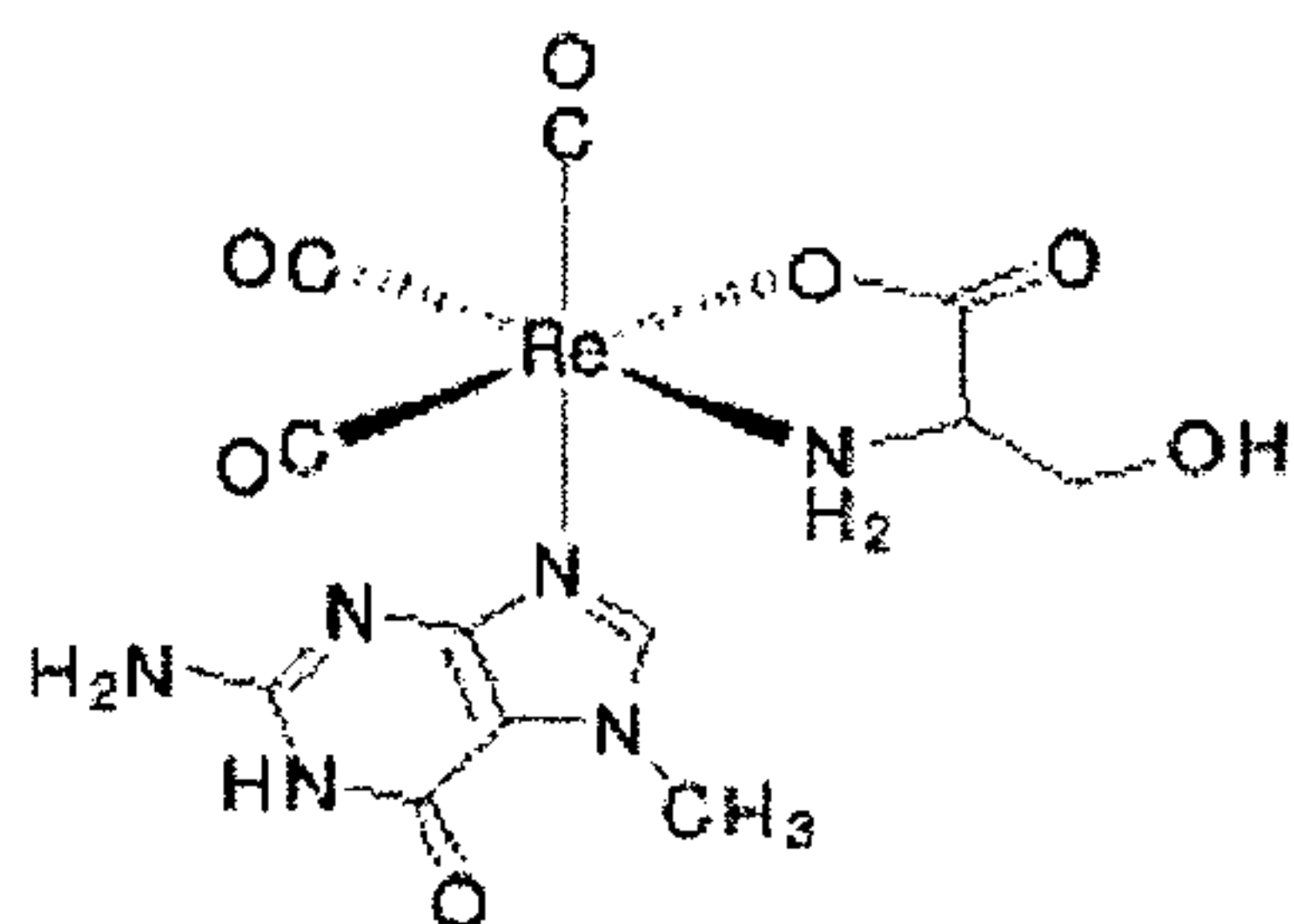

11 (L-ser) and 12 (D-ser)

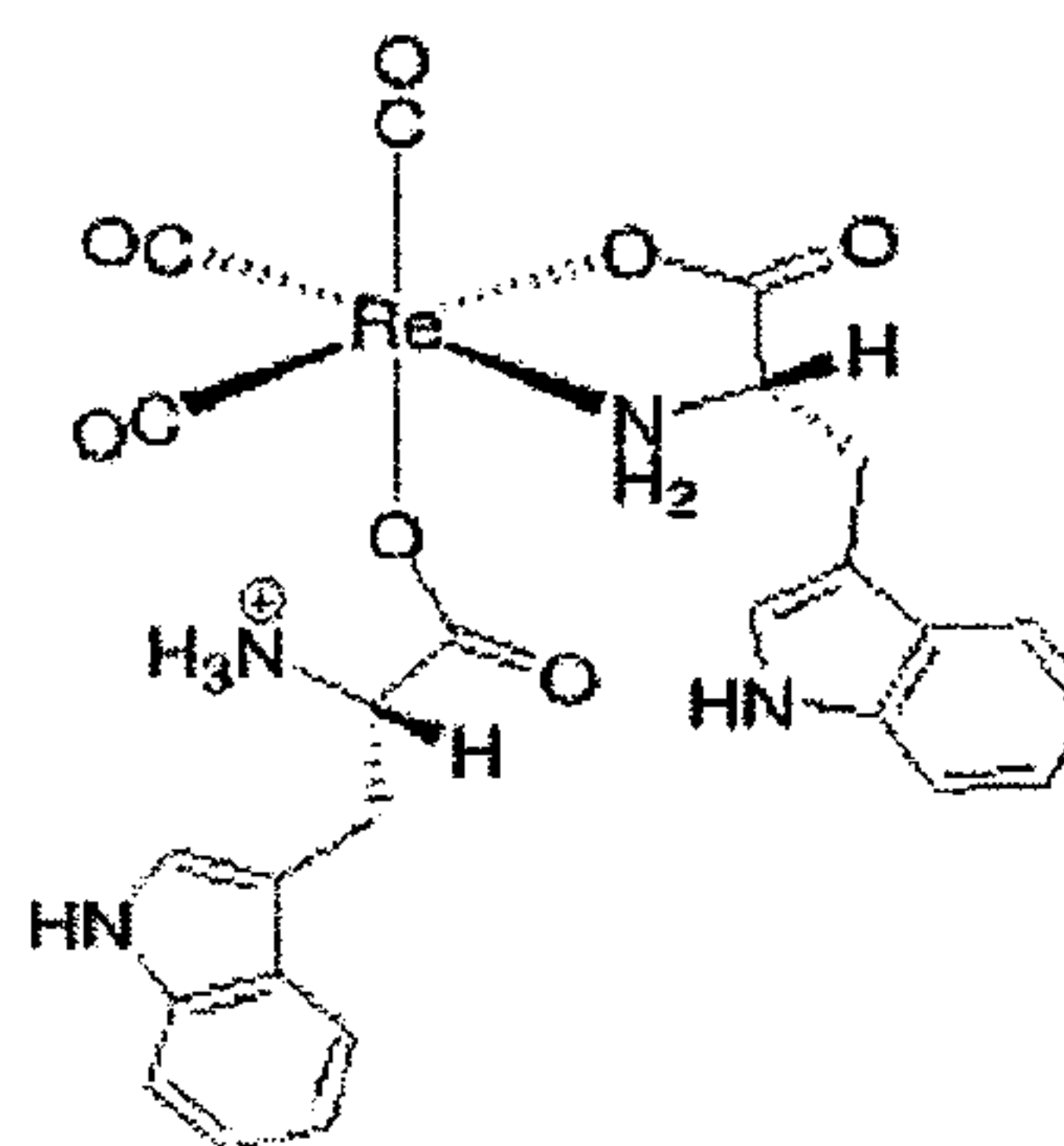

13

and

2. A compound as claimed in claim 1, wherein one or more ligands thereof are coupled to a targeting moiety, wherein the targeting moiety is selected from the group consisting of bombesin, neurotensin, somatostatin, glucosamine, nucleosides, nuclear localizing sequence peptides (NLS-peptides), oligonucleotides, and nucleus targeting molecules.

3. The compound of claim 2, wherein the nucleus targeting molecules are anthracyclines or acridines.

4. A compound according to any one of claims 1 to 3, for use in the treatment of cancer.

5. Use of a compound according to any one of claims 1 to 3, for the preparation of a chemotoxic medicament for the treatment of cancer.

6. Use according to claim 5 wherein the medicament is radiotherapeutic.

7. Use of a compound according to any one of claims 1 to 3 for the treatment of cancer.

1/12

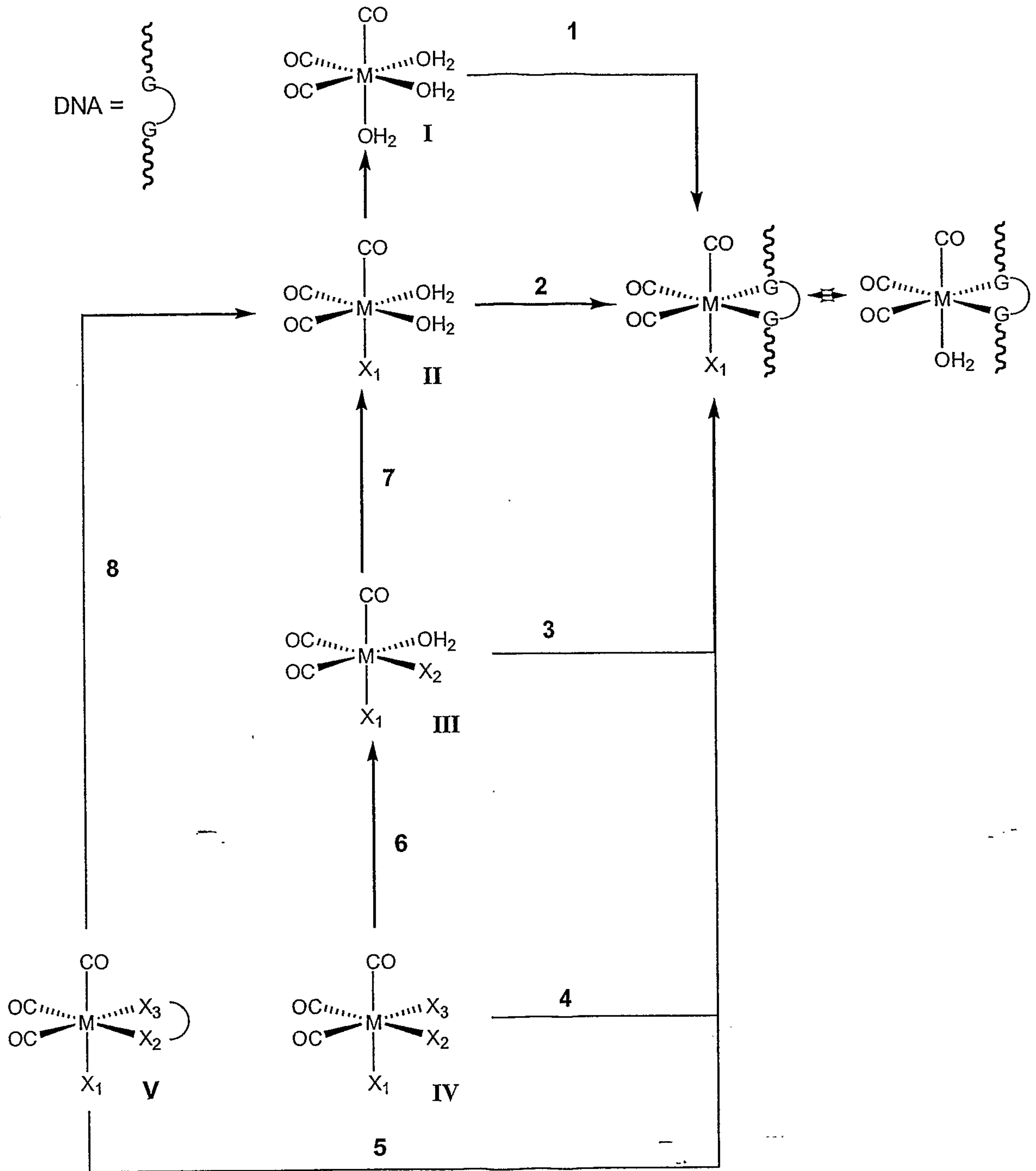

Fig. 1

2/12

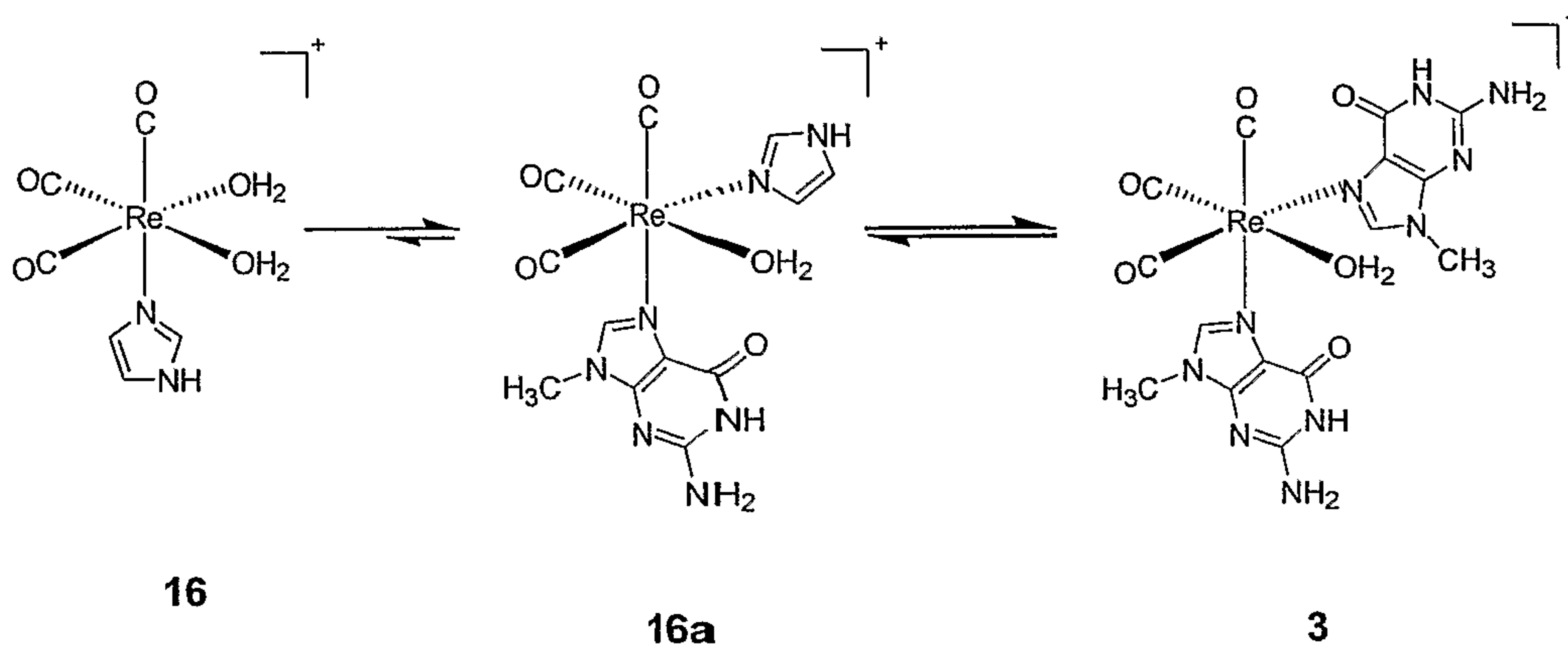

Fig. 2

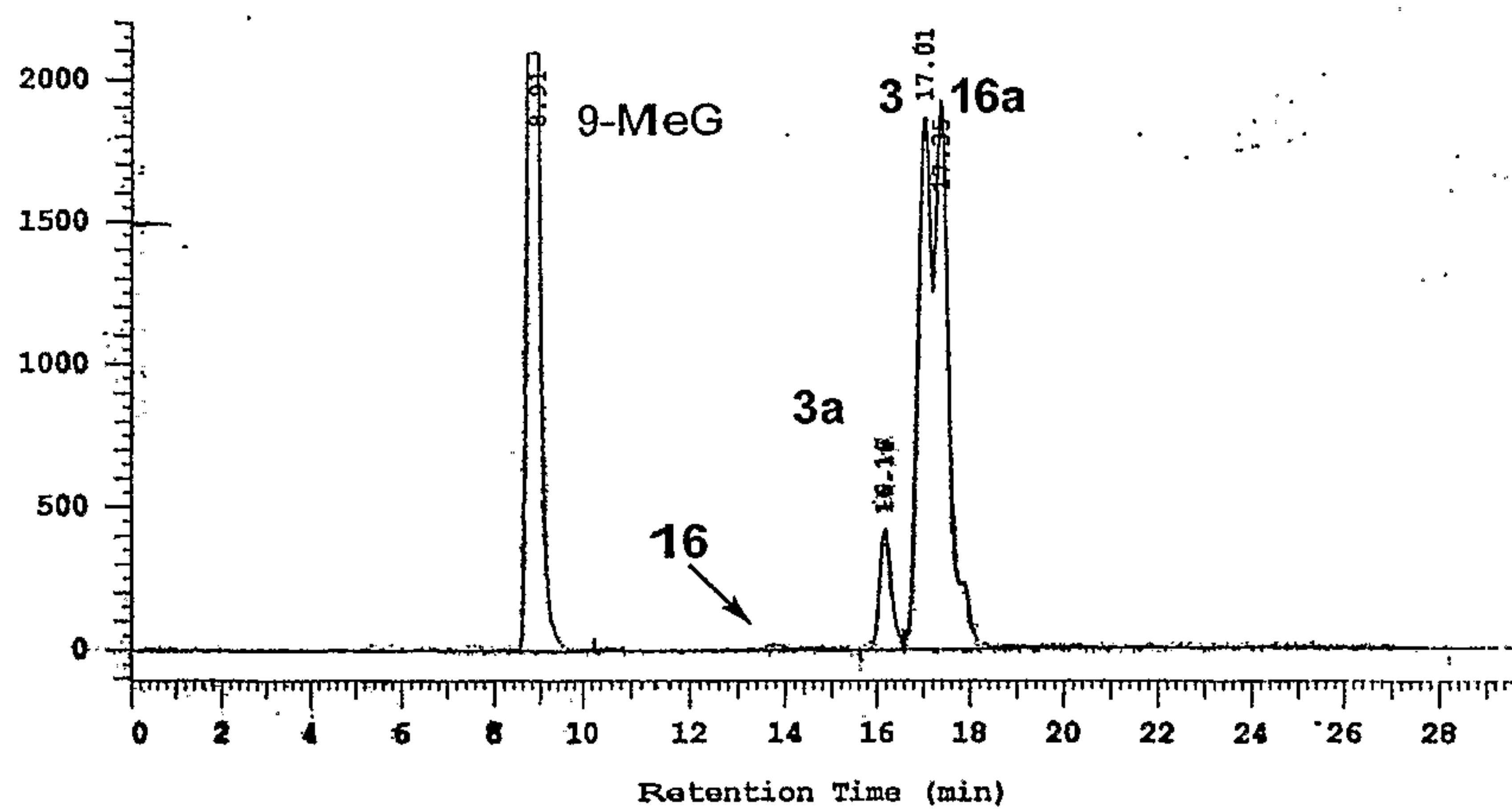

Fig. 3

3/12

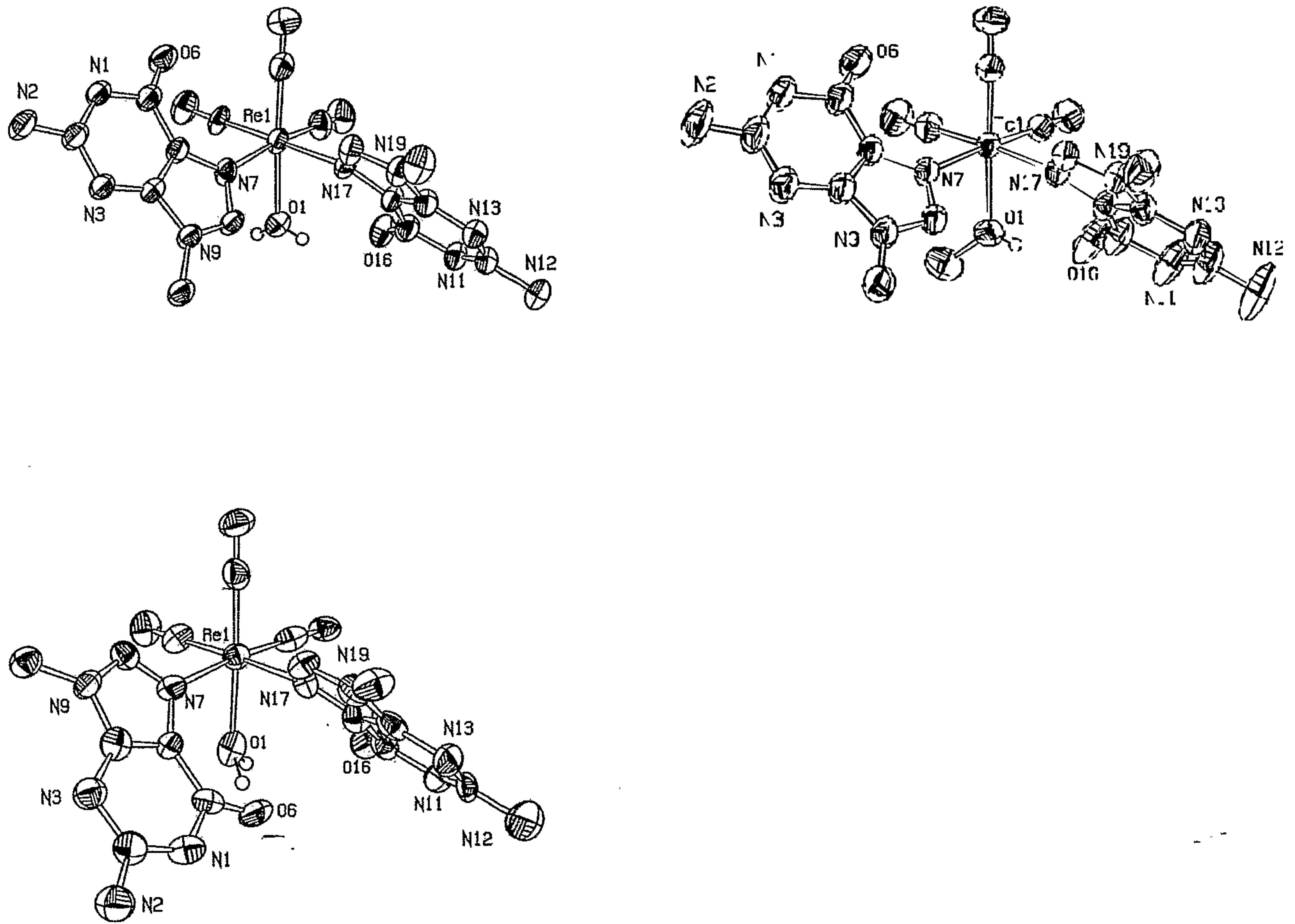

Fig. 4

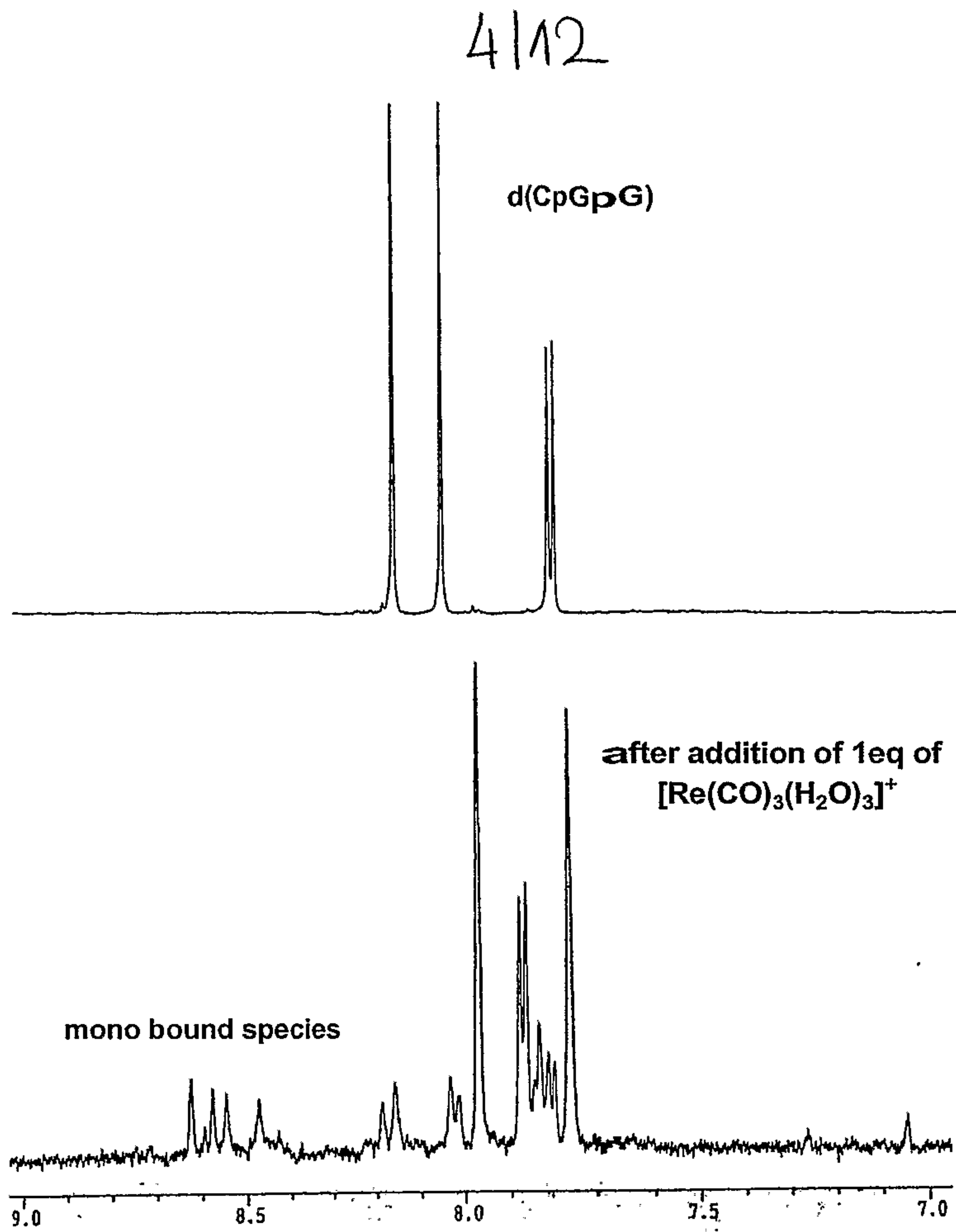

Fig. 5A

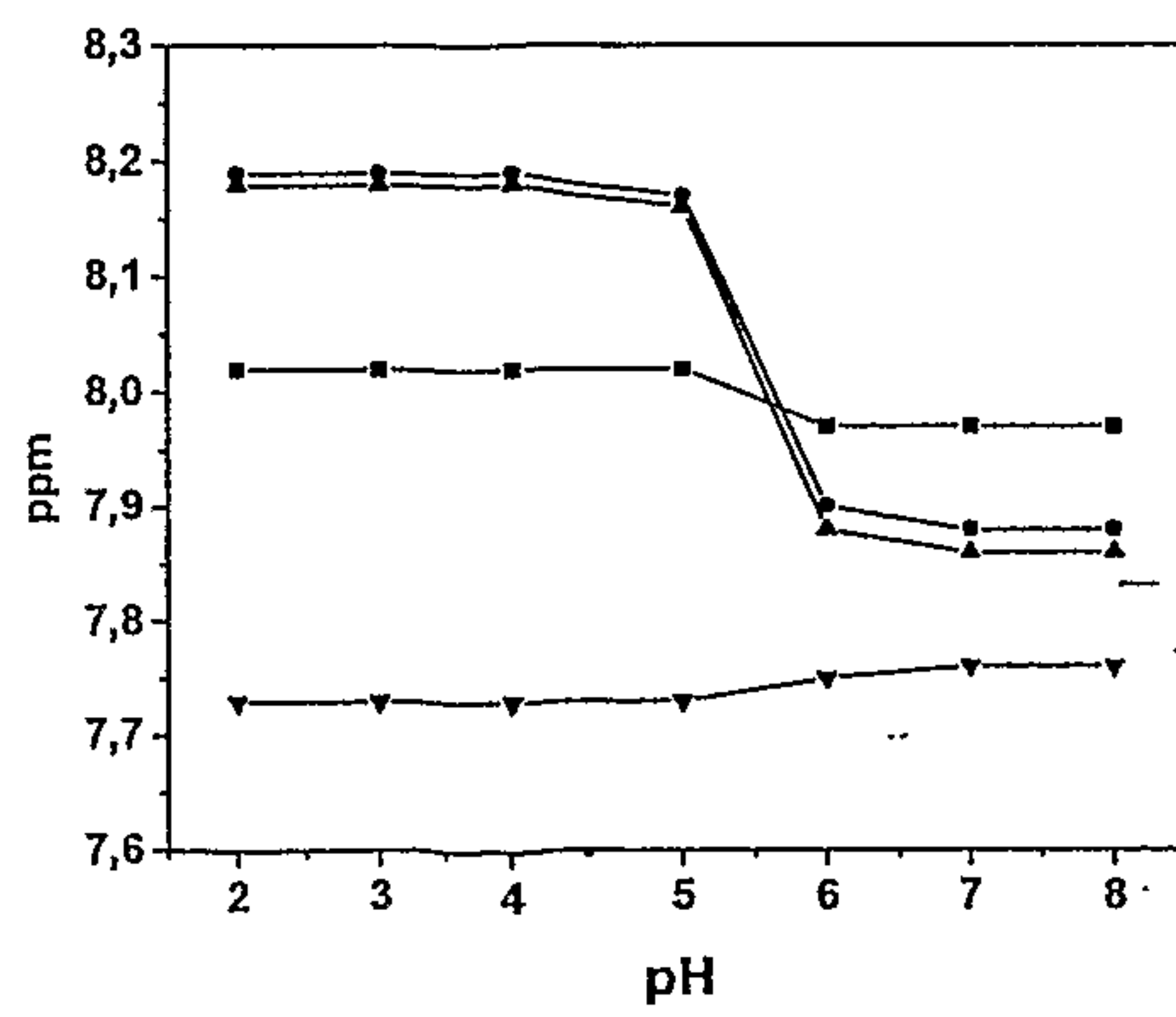

Fig. 5B

5/12

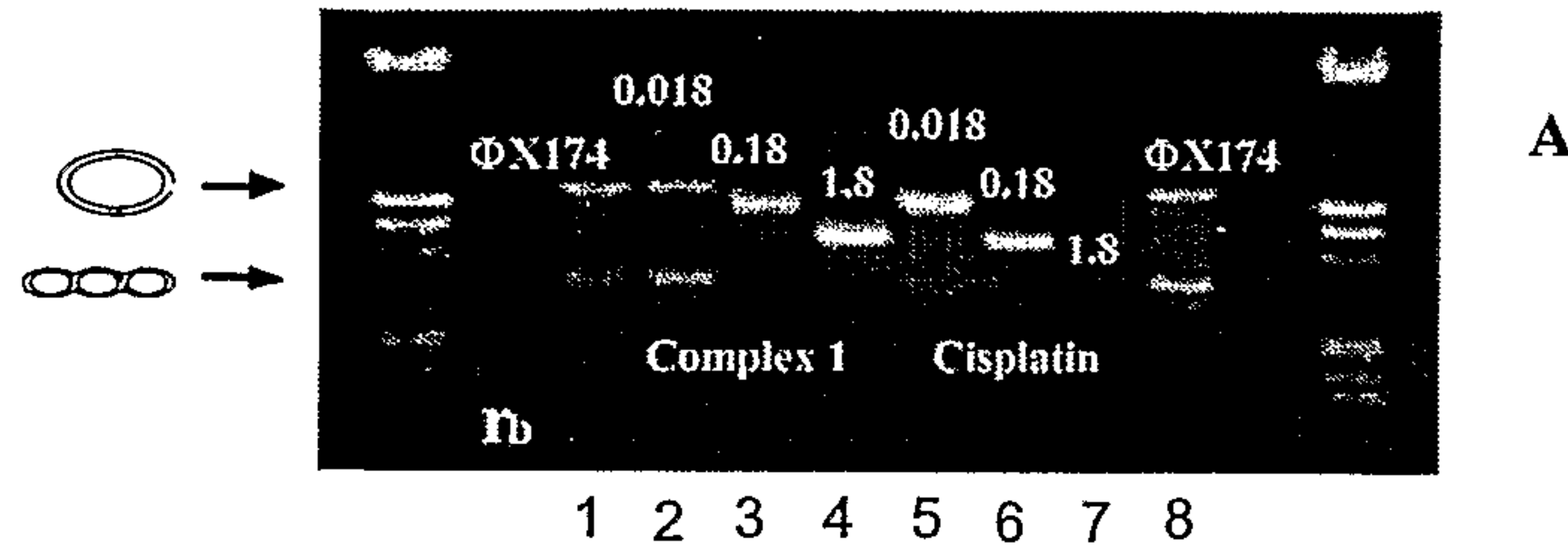

Fig. 6A

H₂O, incubated at 37°C, 22h

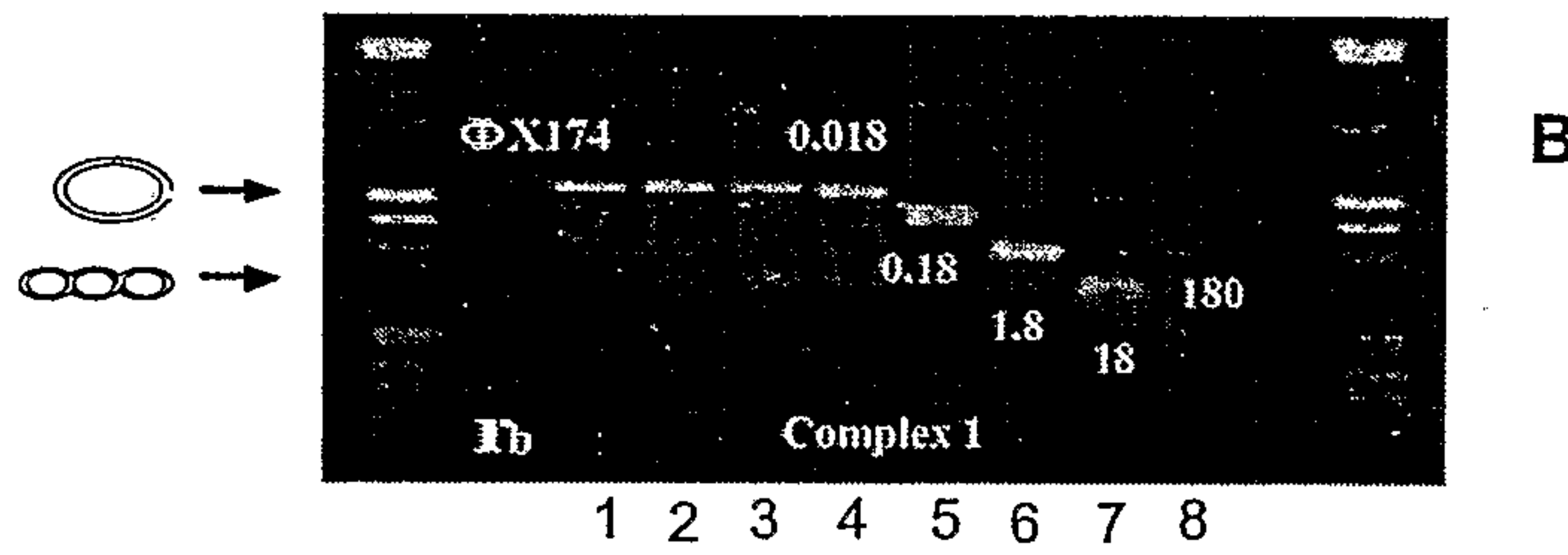

Fig. 6B

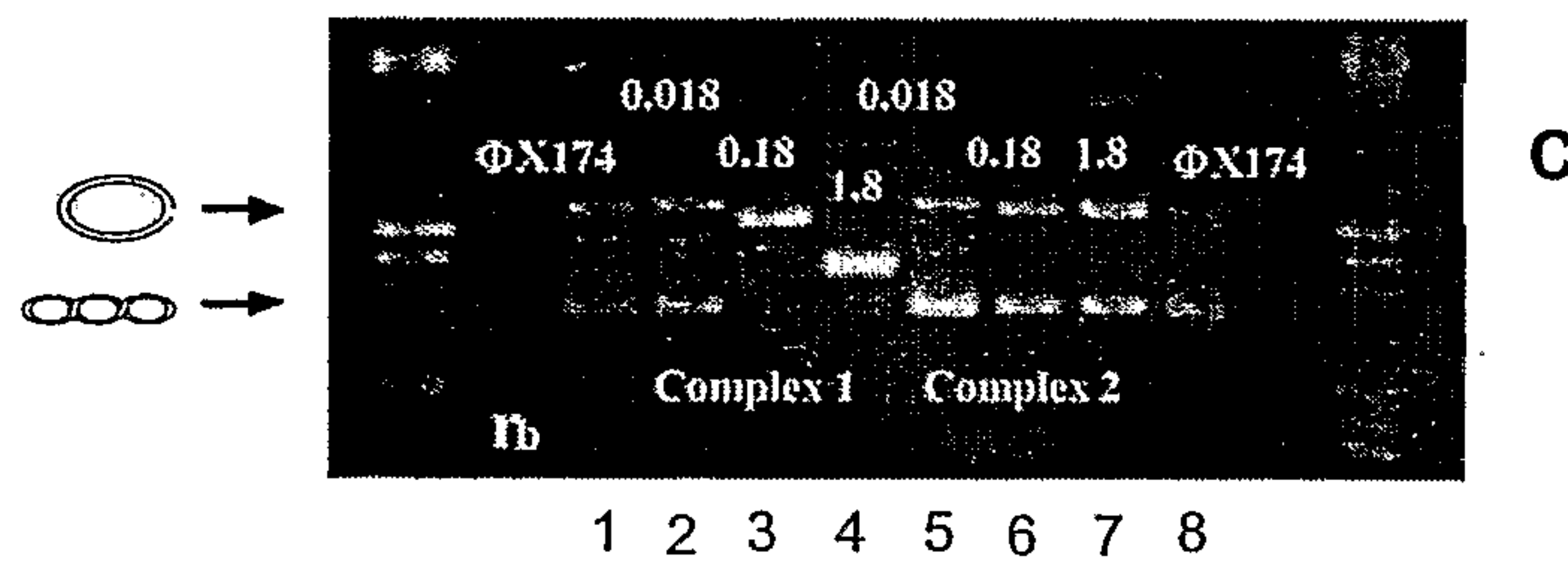

Fig. 6C

6/12

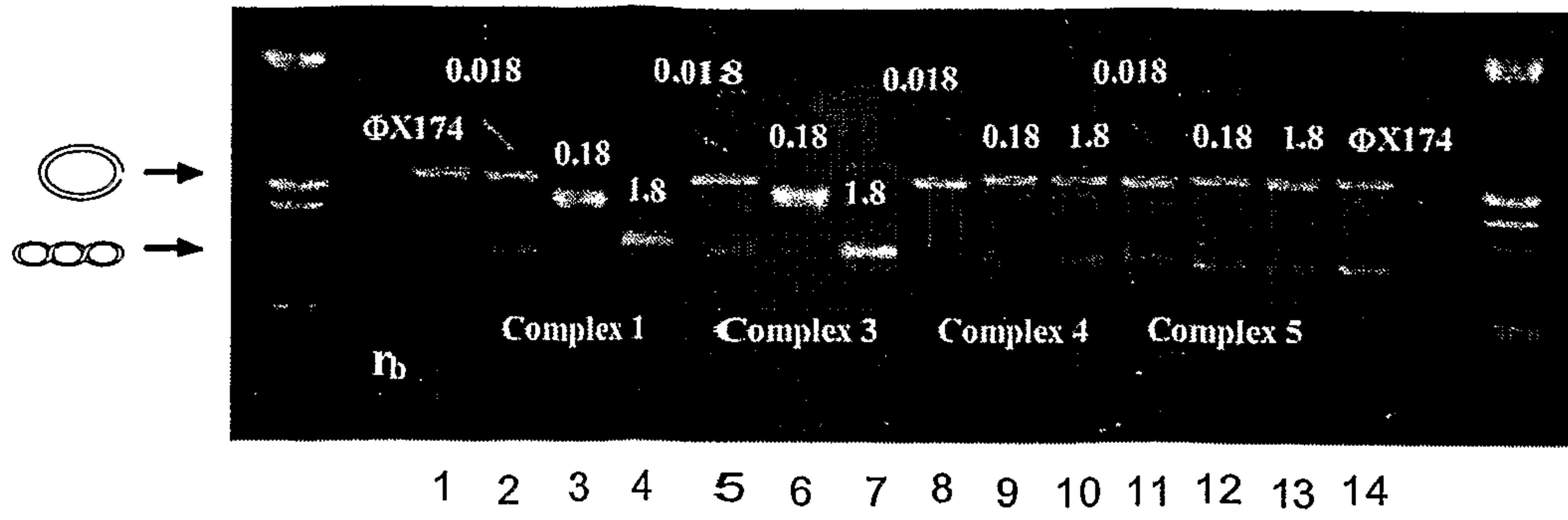

Fig. 7

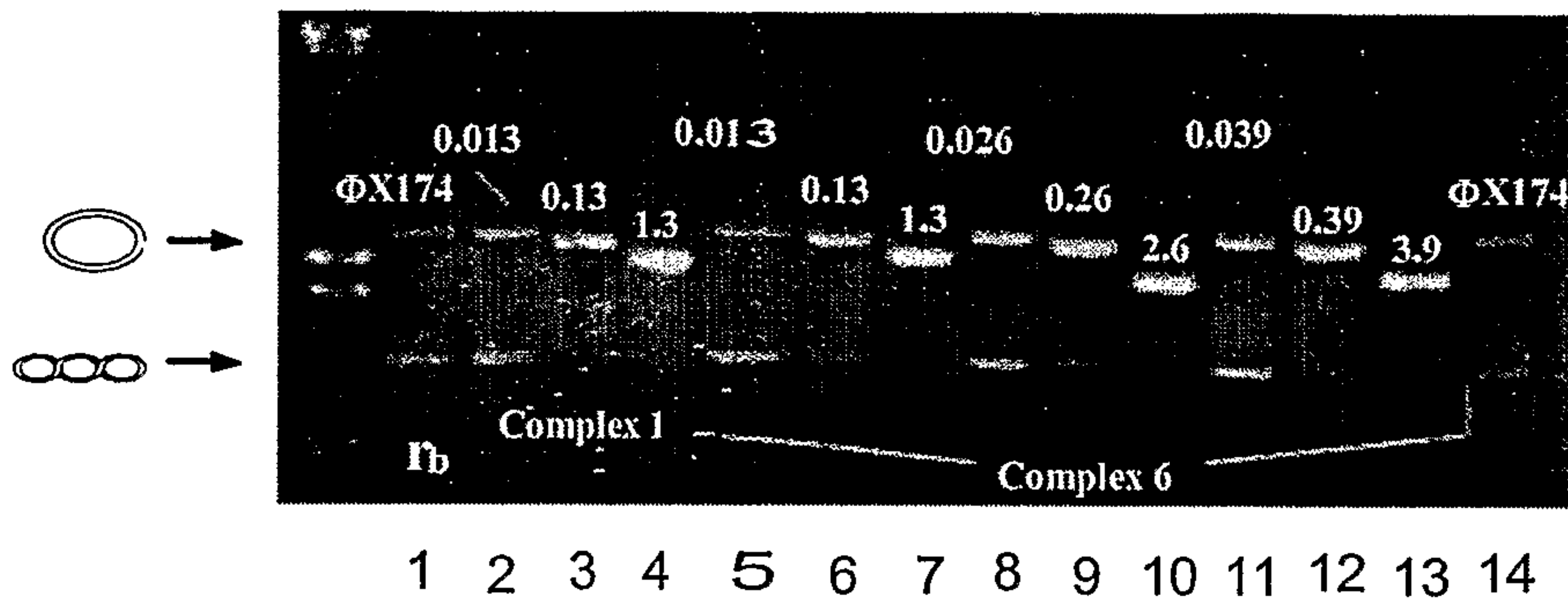

Fig. 8A

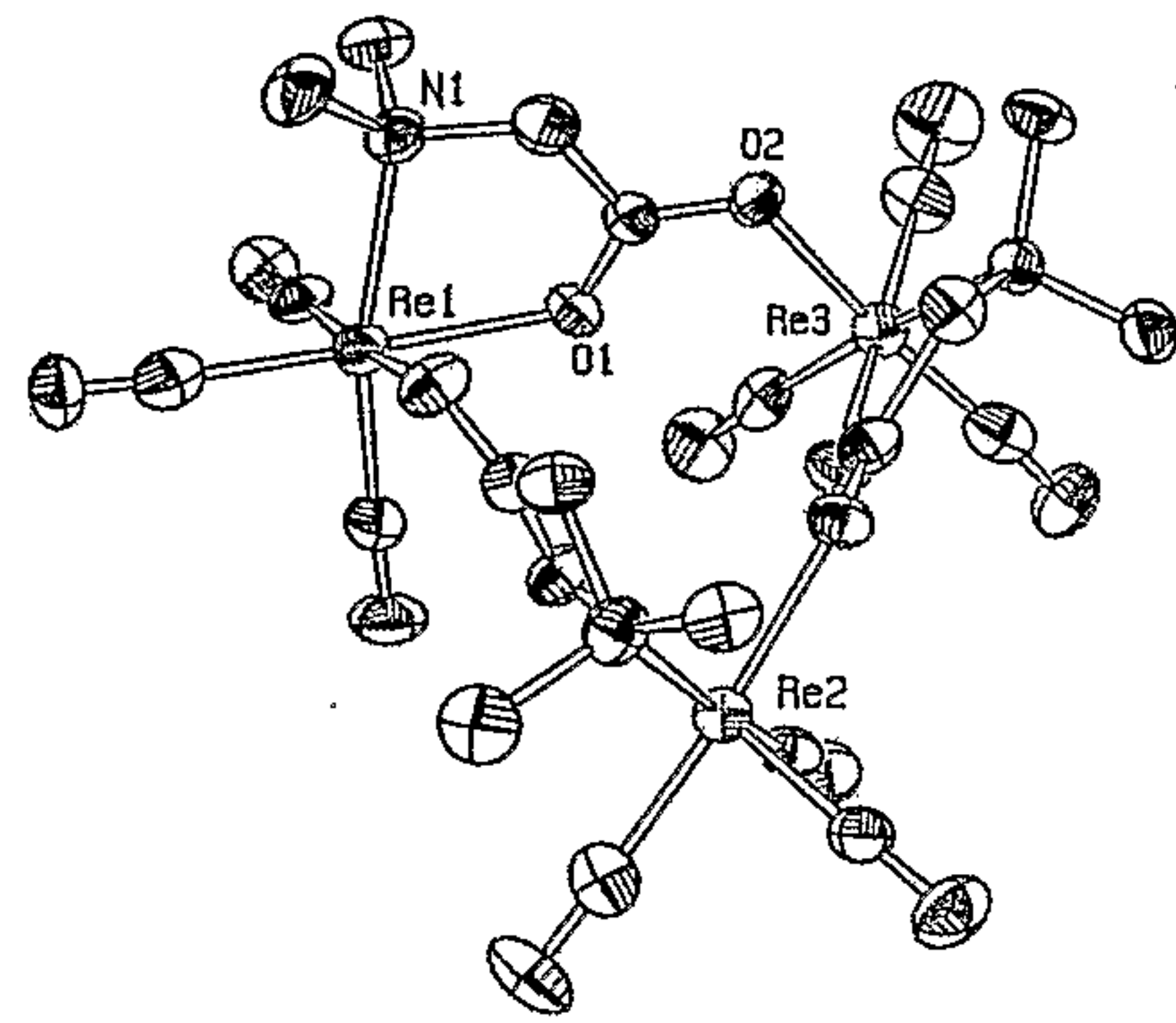
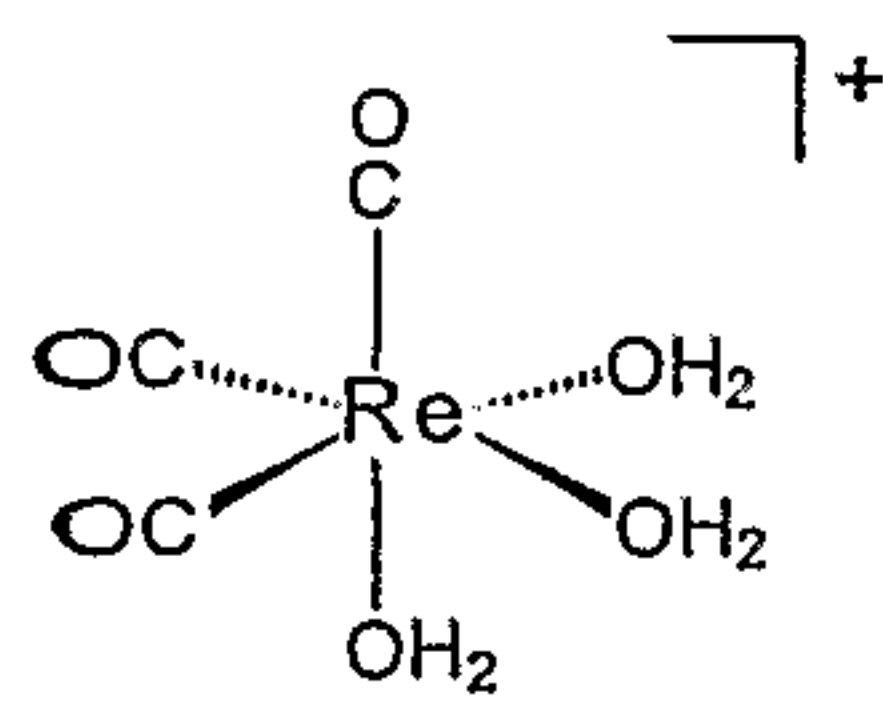
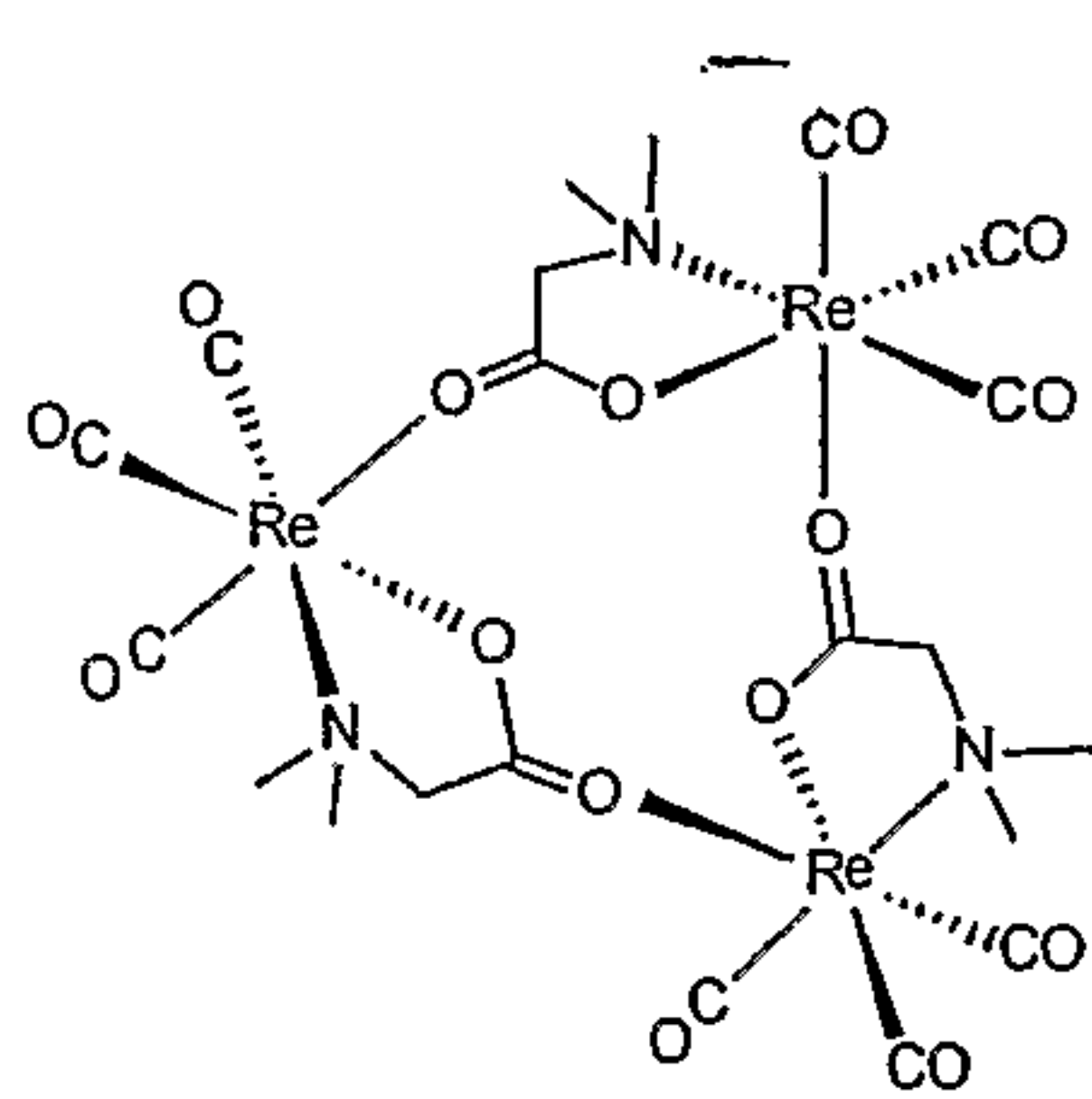

Fig. 8B

7/19

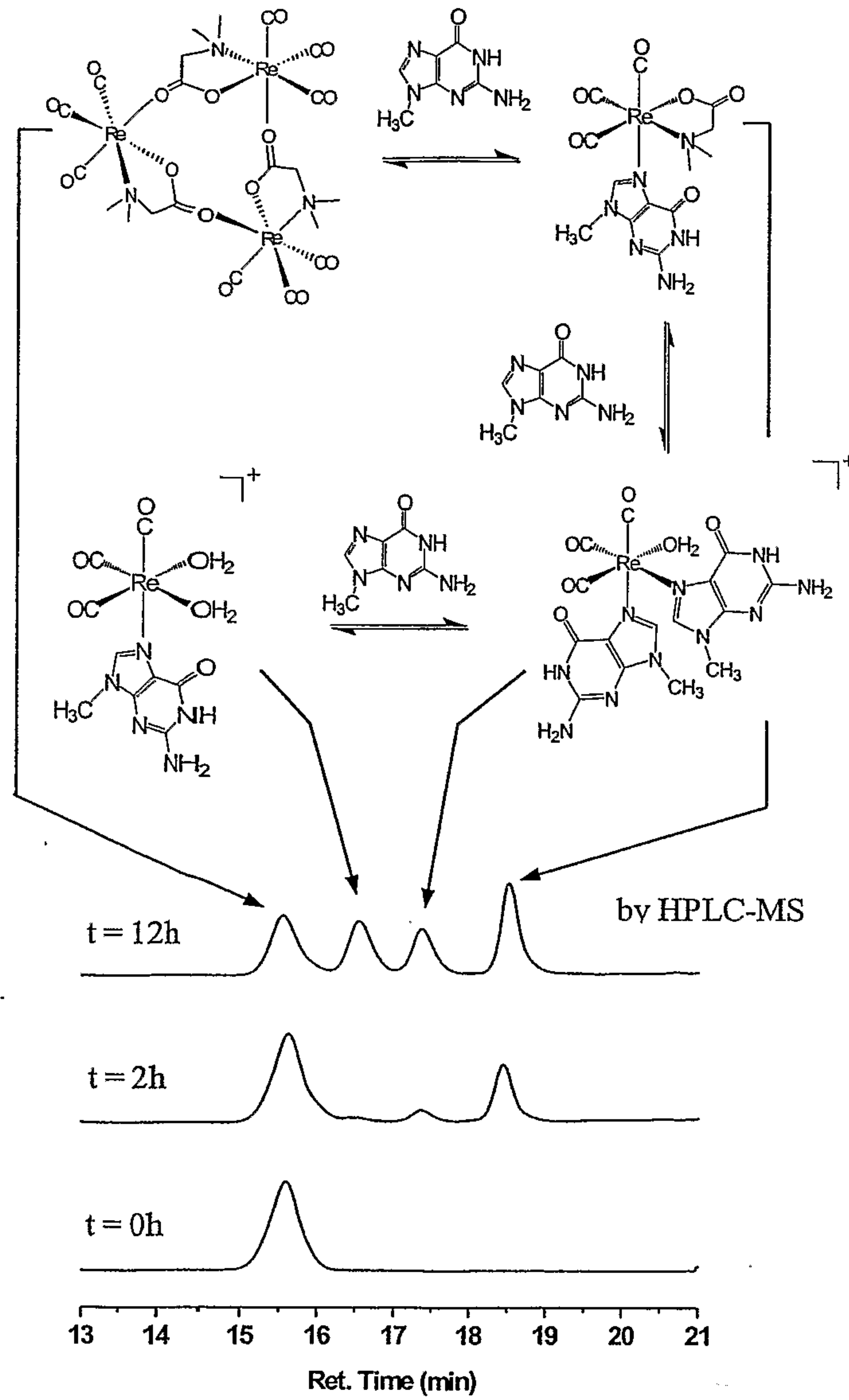
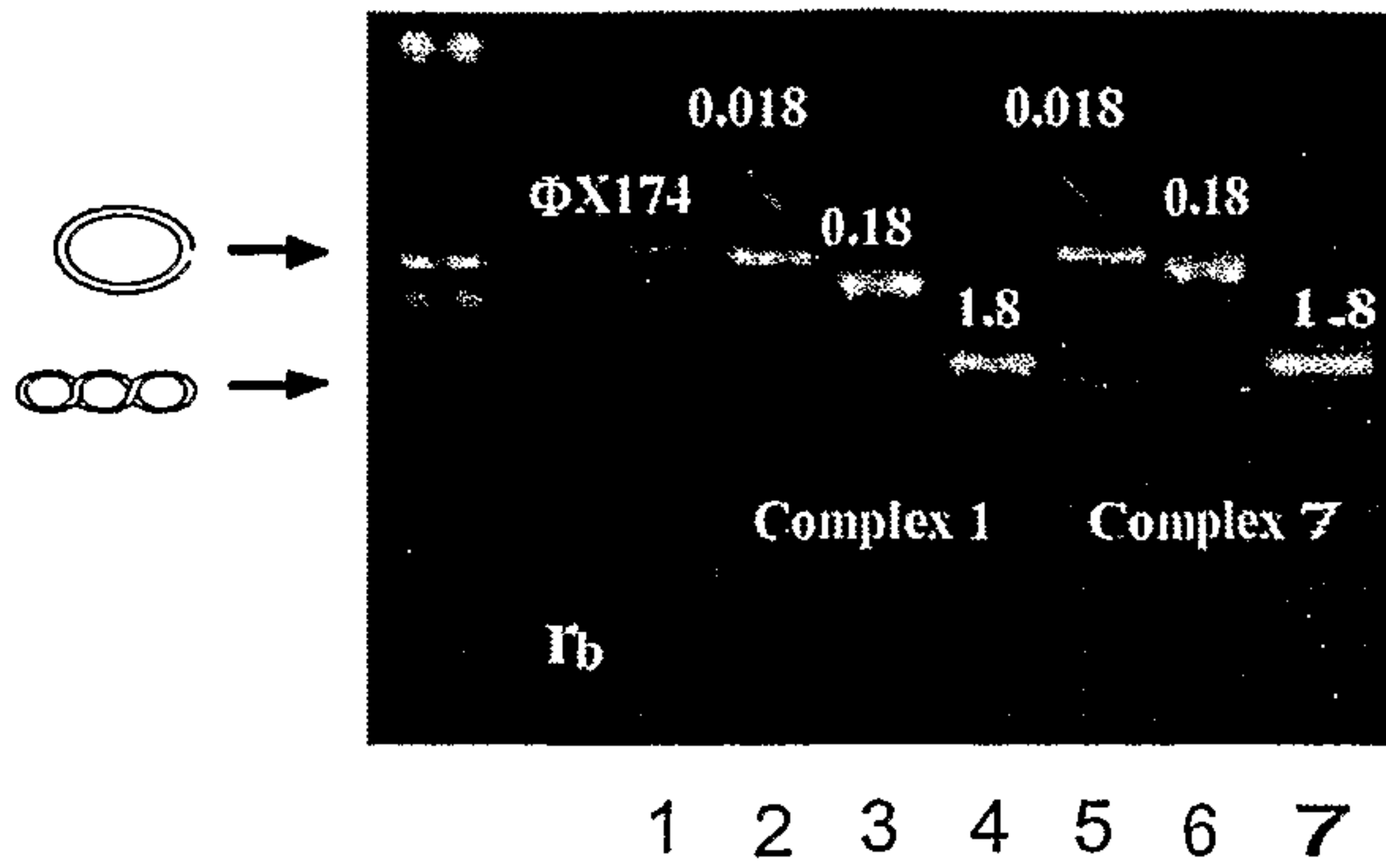
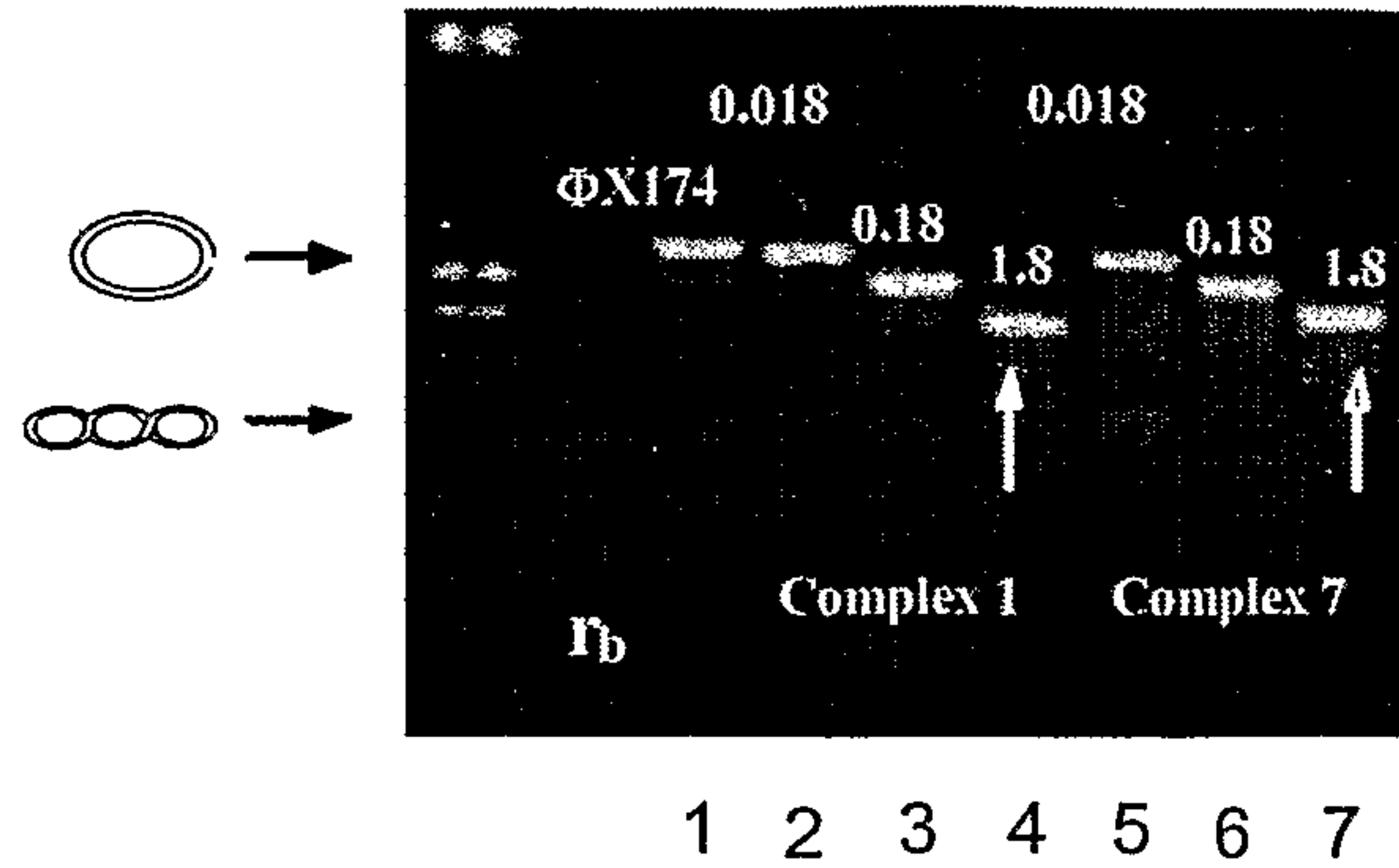

Fig. 8C

8/12
Fig. 9



A



B

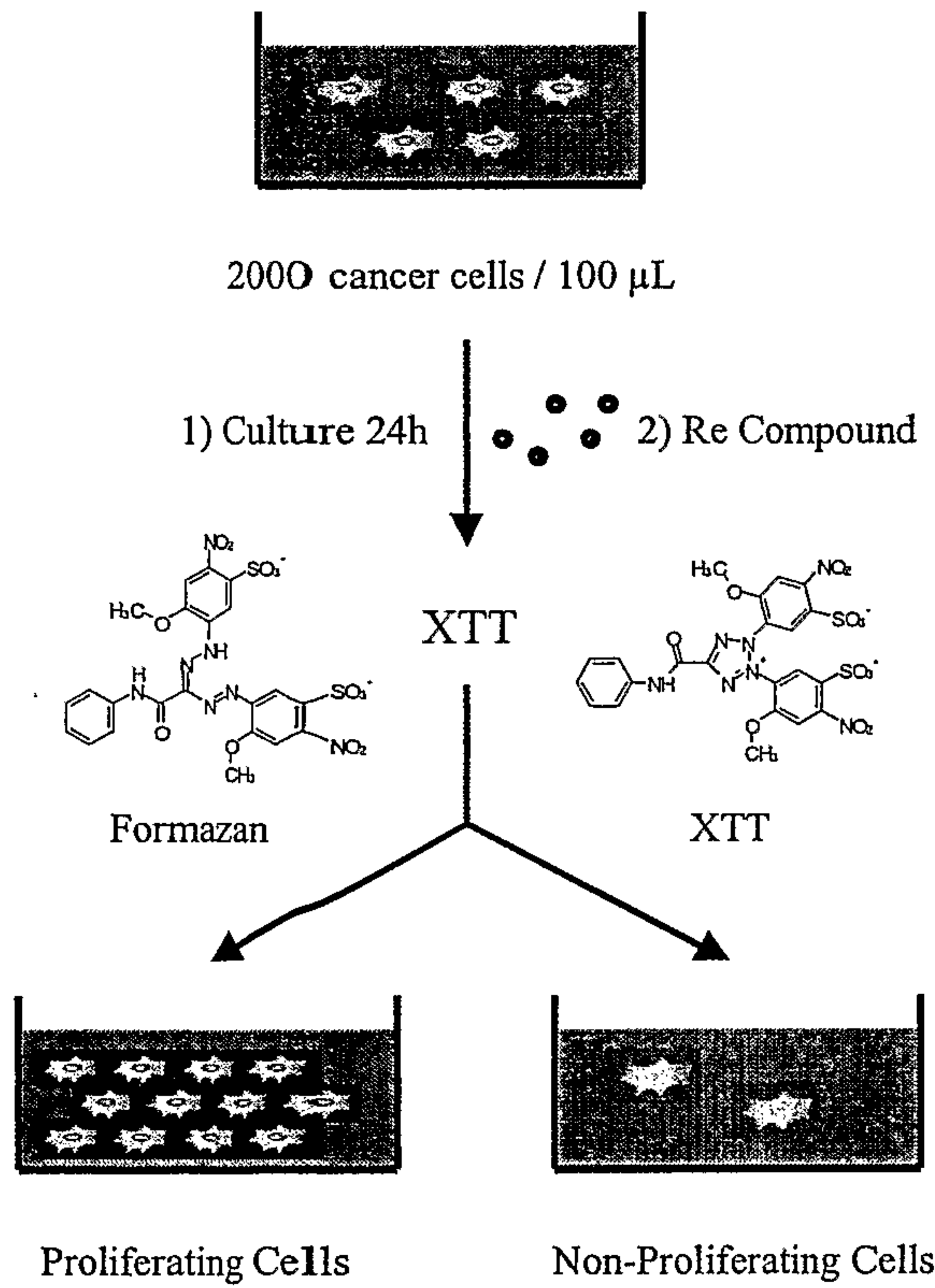
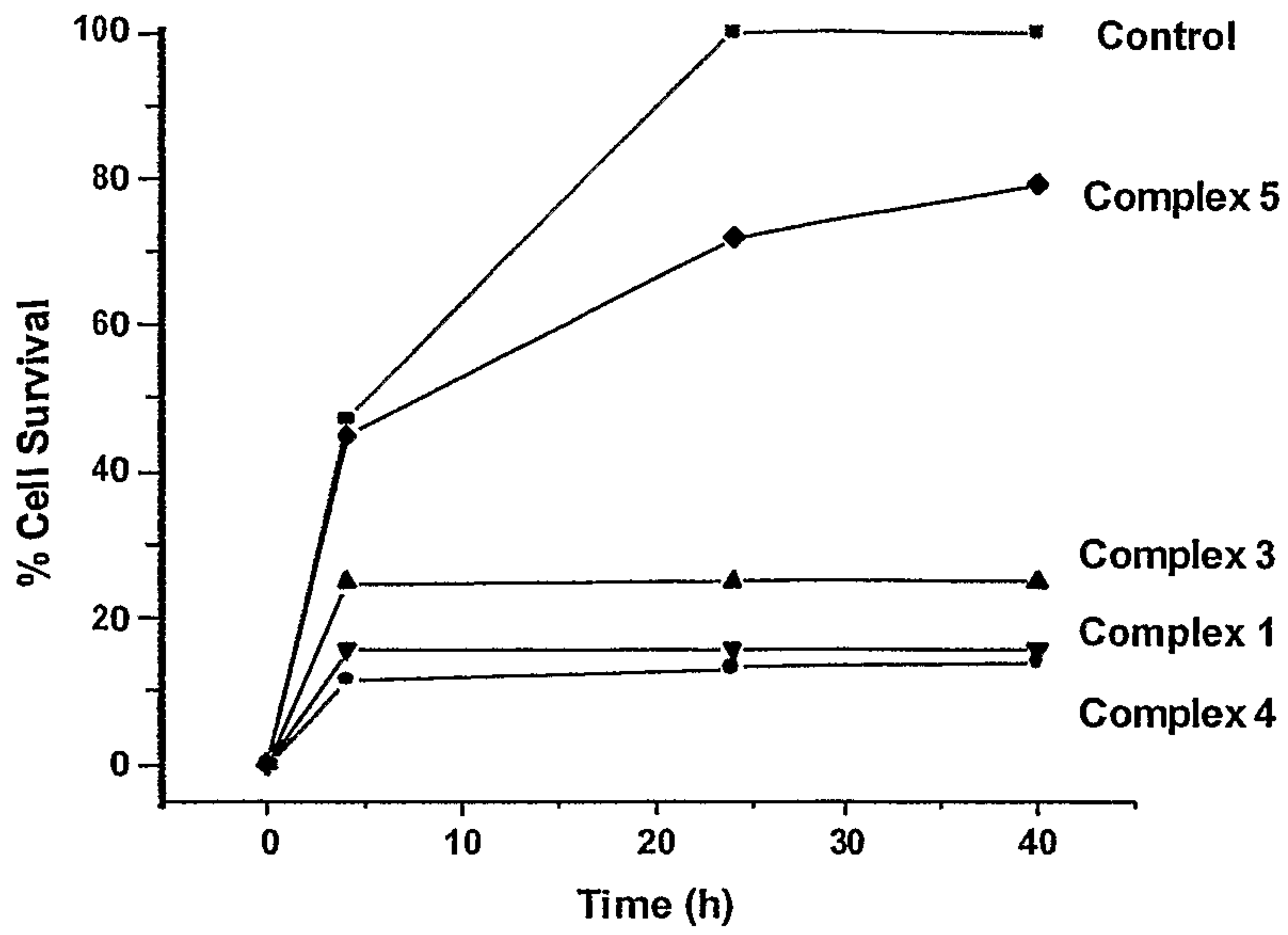

Fig. 10

9/12



Effect of Re Compunds on Proliferation of MDA-MB-4355 Breast Cncer Cells

Fig. 11

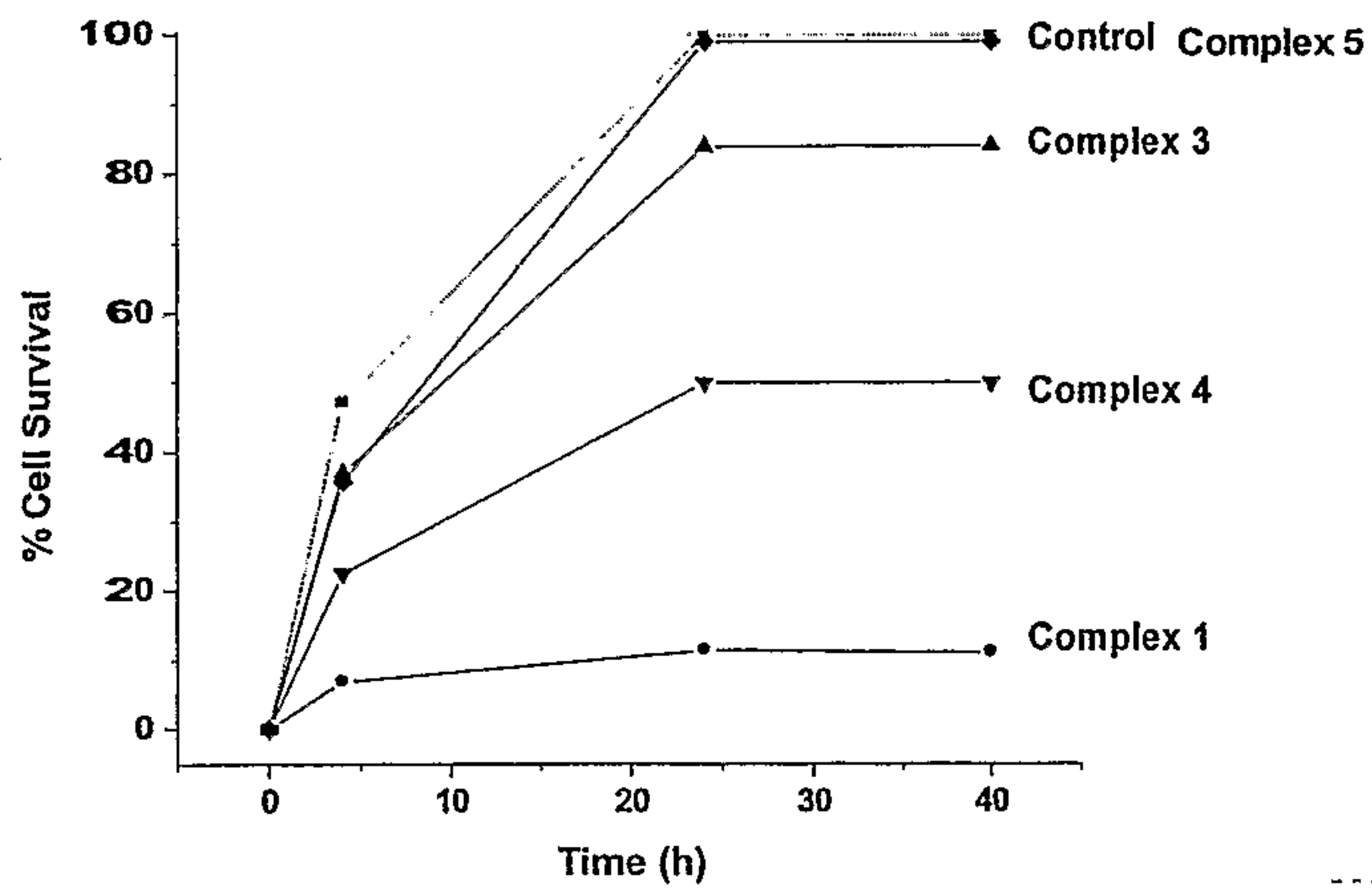

Effect of Re Compunds on Proliferation of OVMZ-6-WT Ovarian Cancer Cells

Fig. 12

10/12

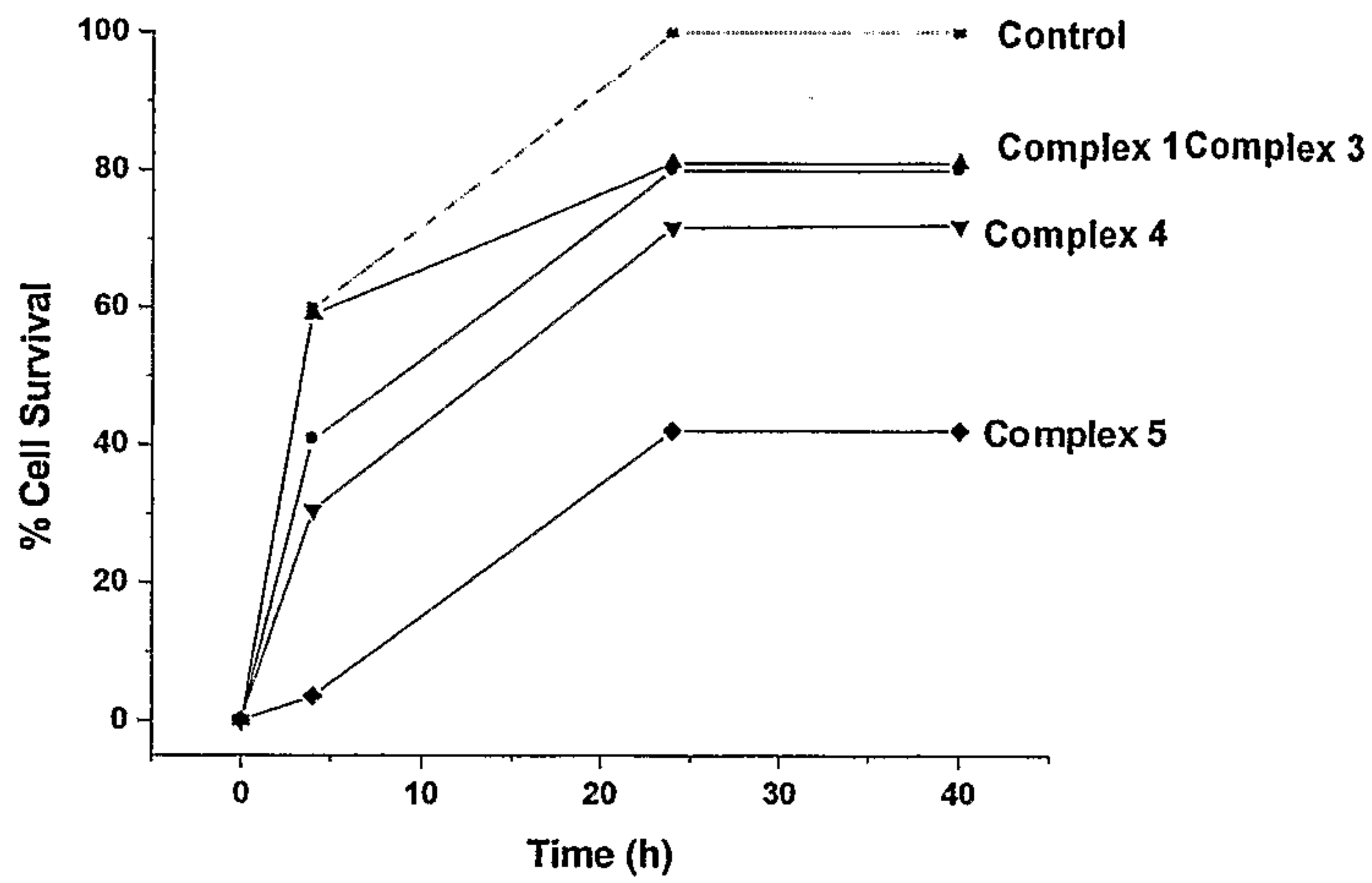

Effect of Re Compounds on Proliferation of HSC45-M2 Gastric Cancer Cells

Fig. 13

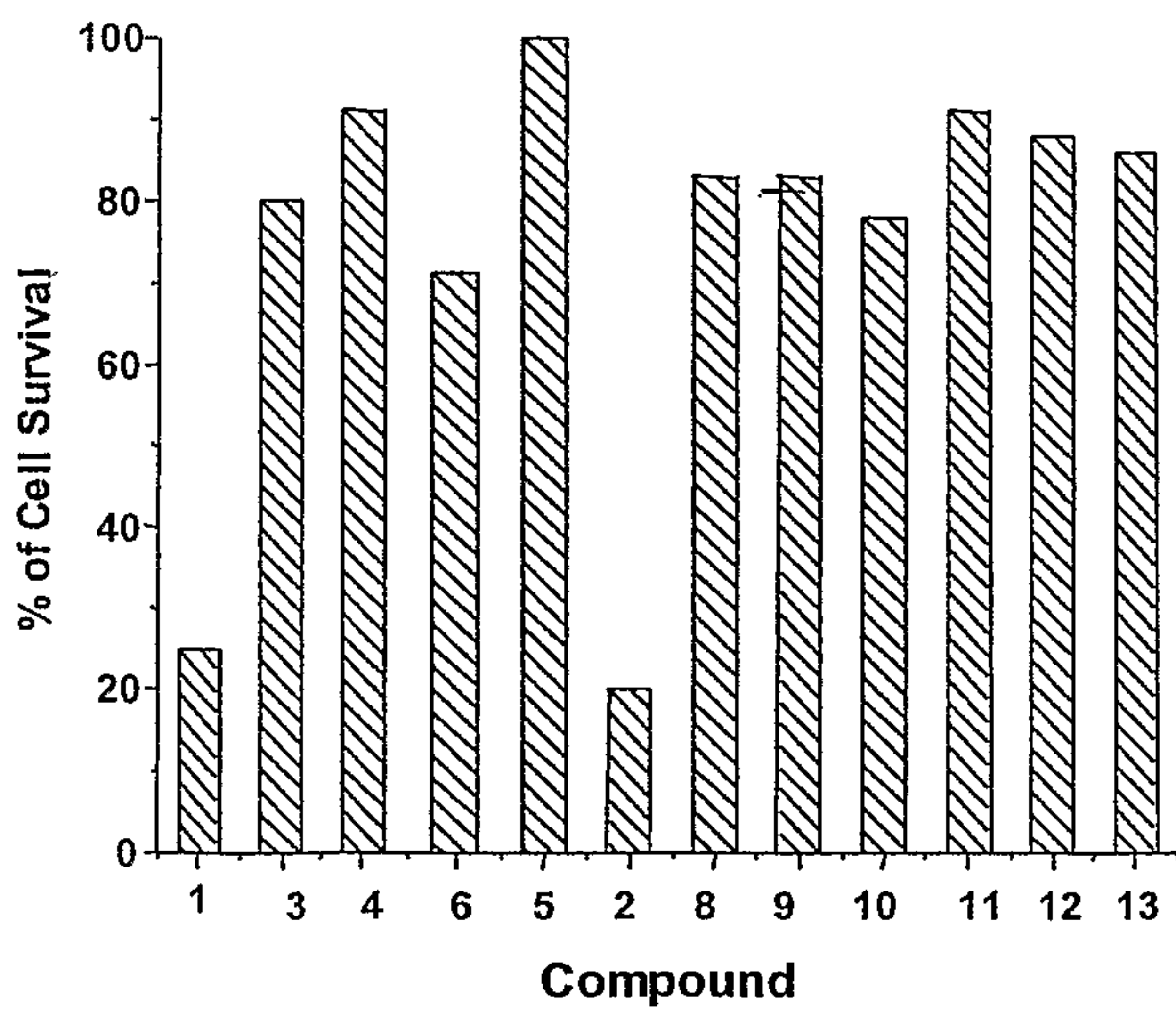

Fig. 14A

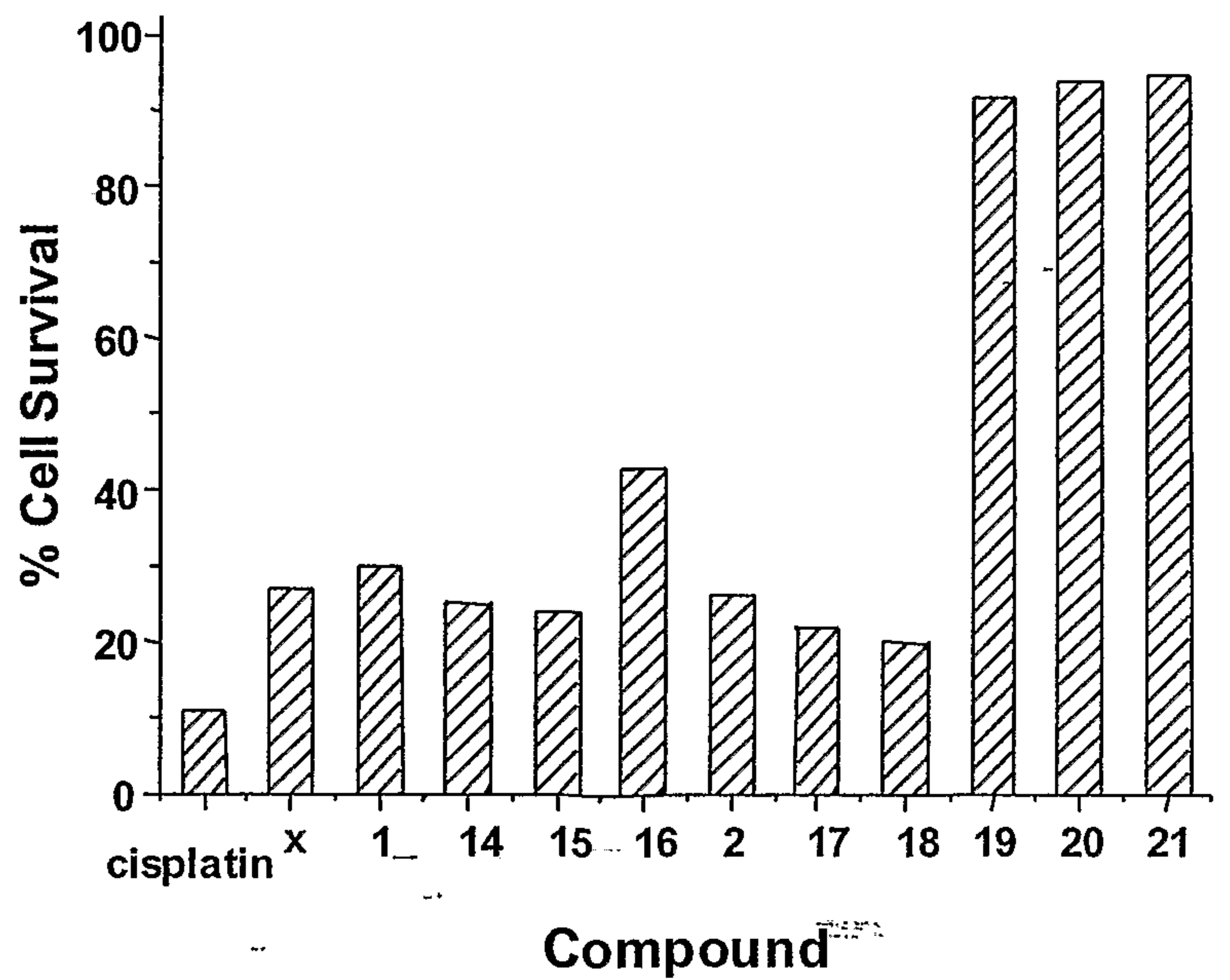
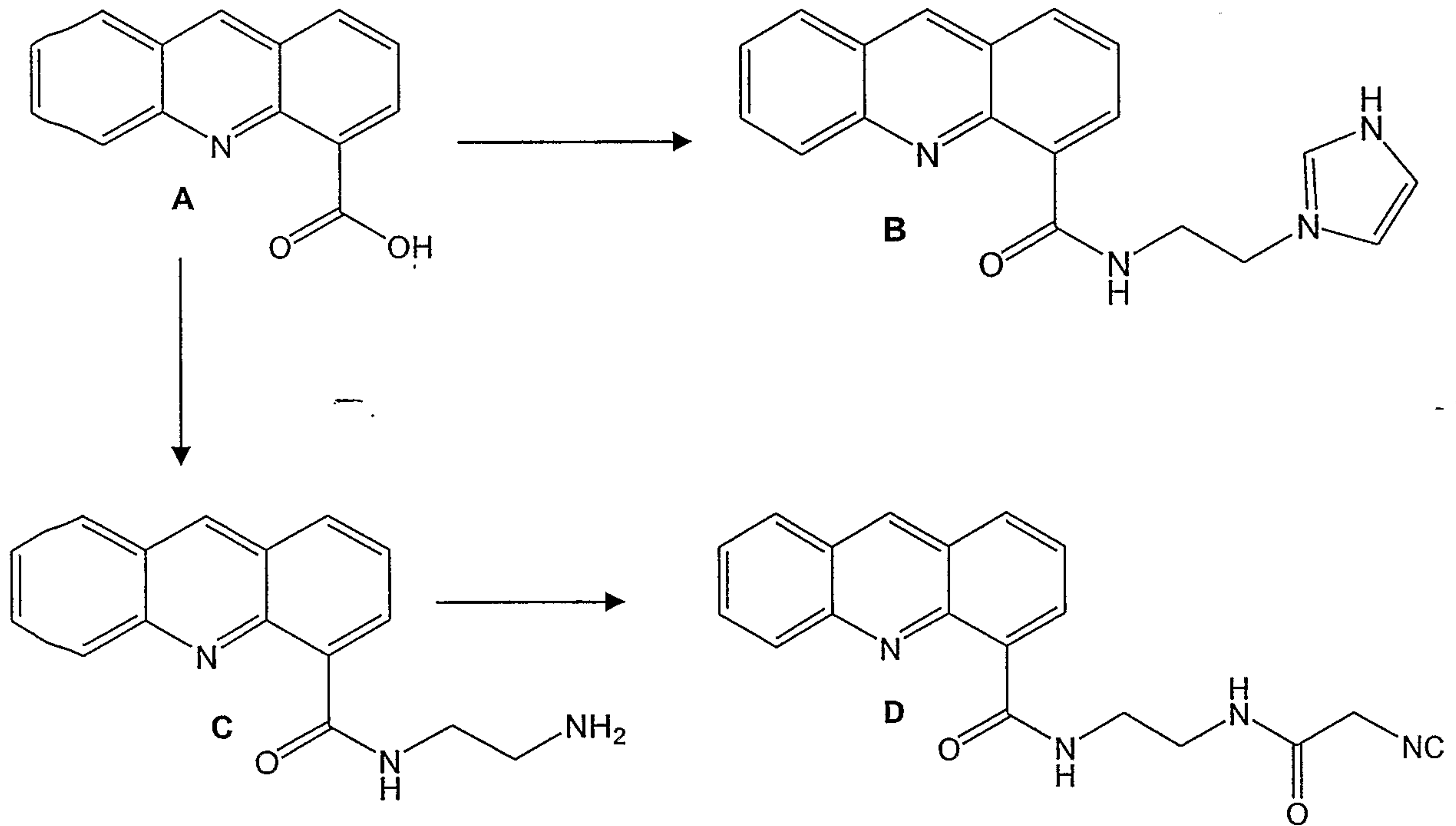

Fig. 14B

11/19

Fig. 15



12/12

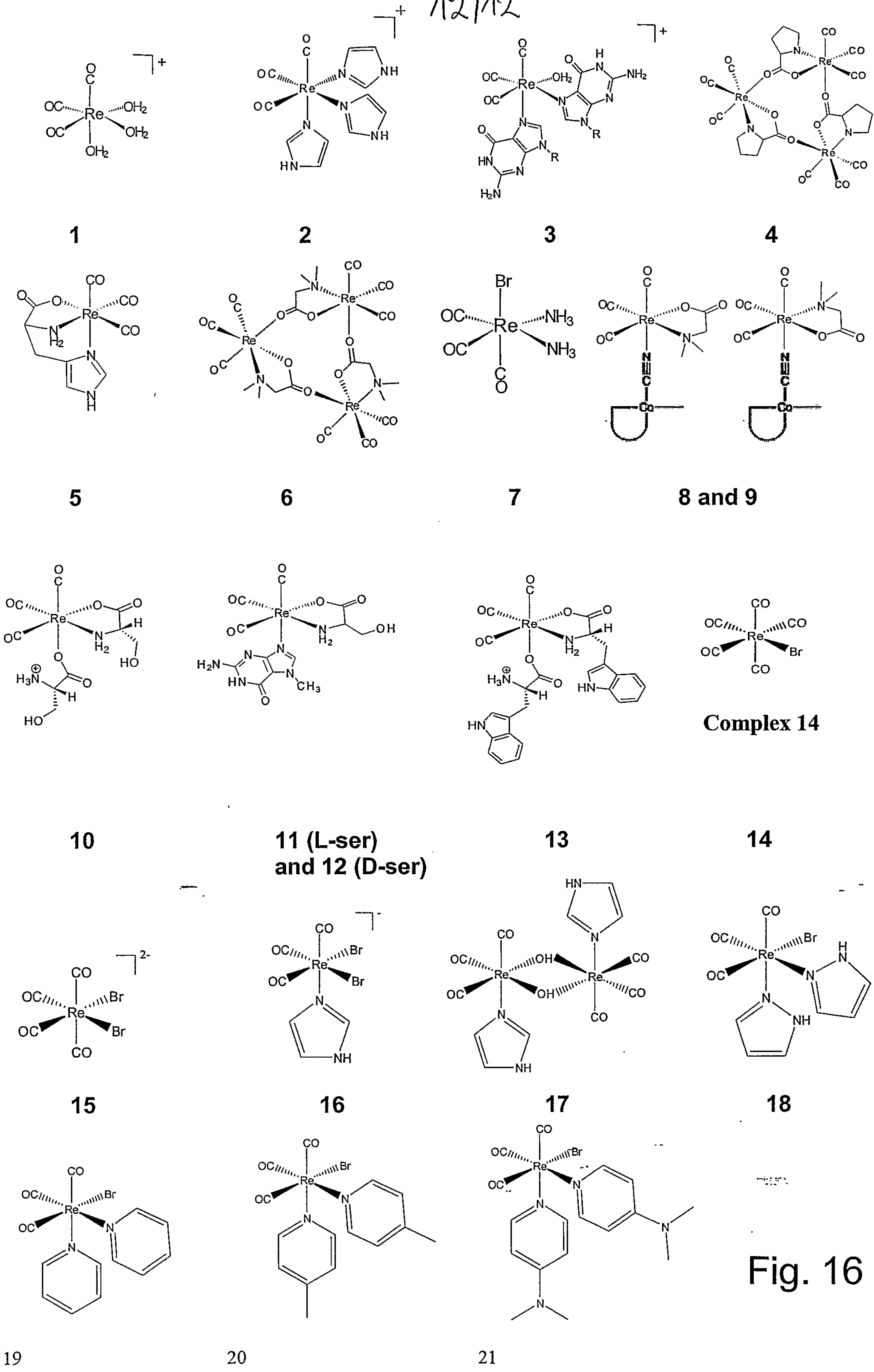
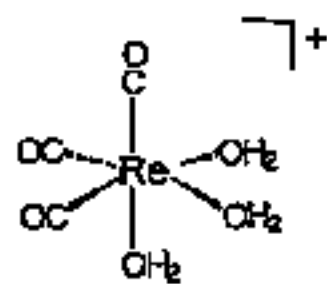
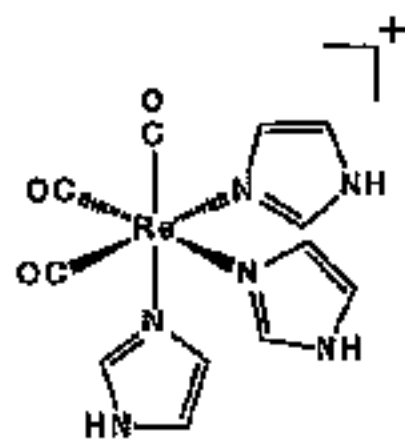

Fig. 16



1



2

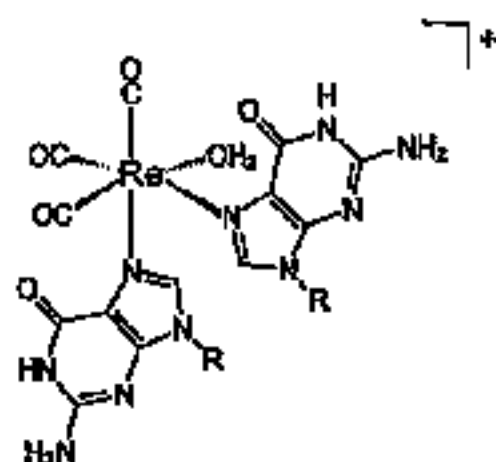

3

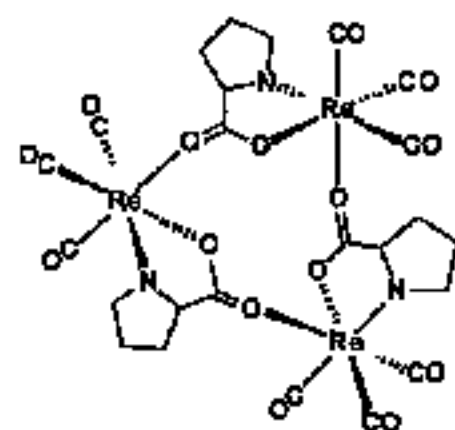

4

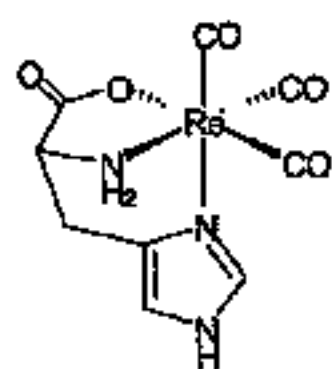

5

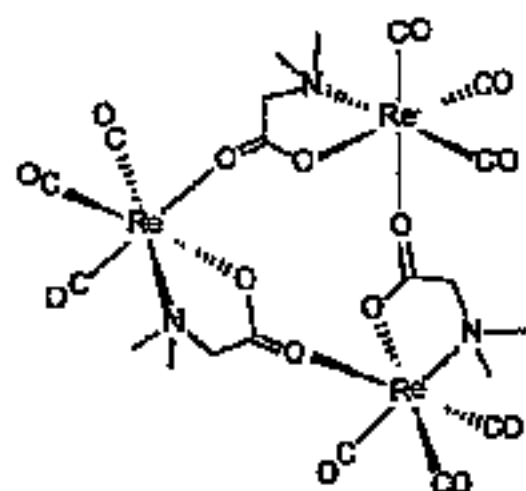

6

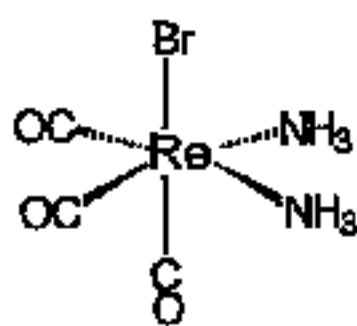

7

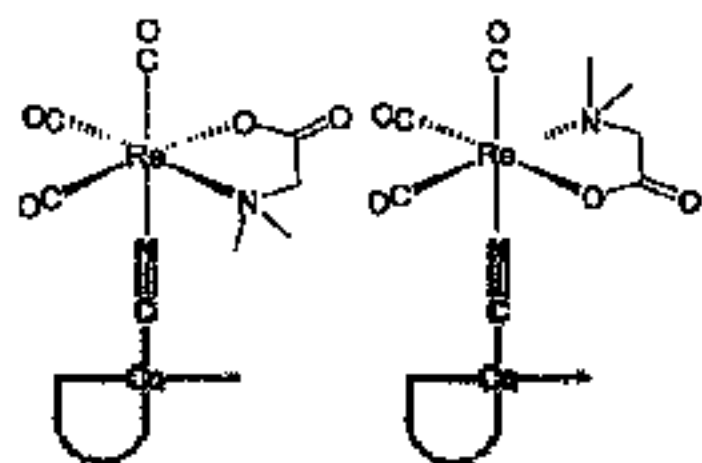

8 and 9

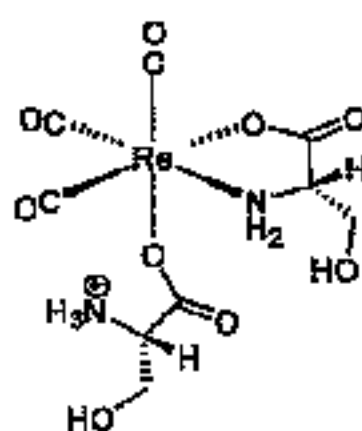

10

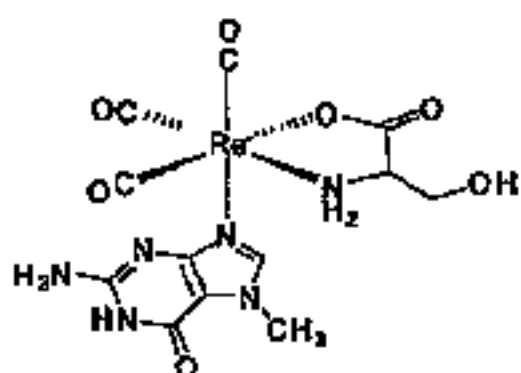

11 (L-ser)
and 12 (D-ser)

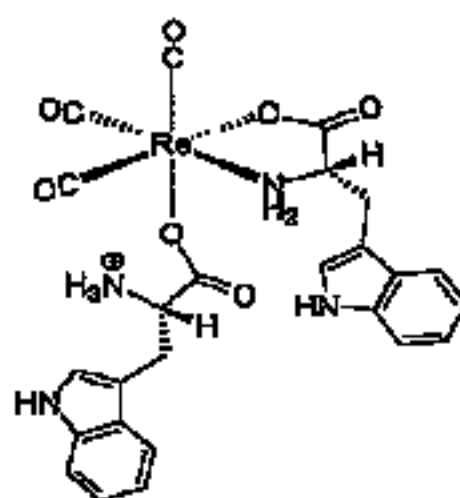

13

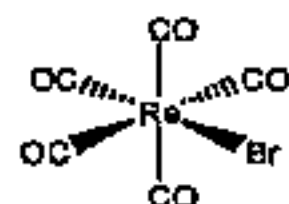

Complex 14

14

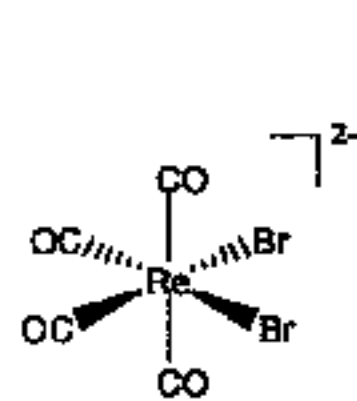

15

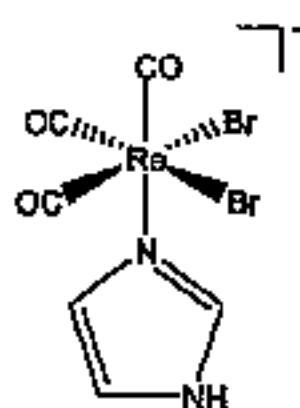

16

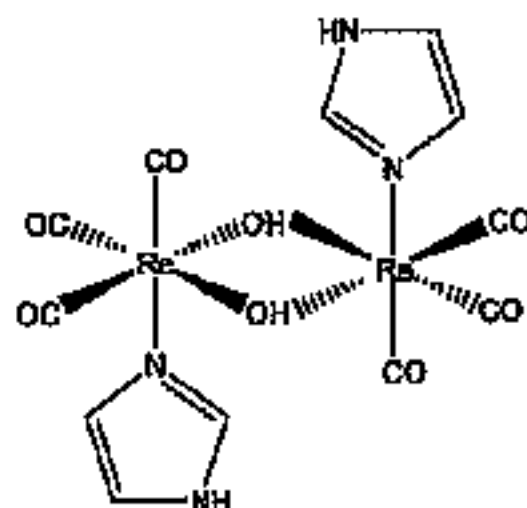

17

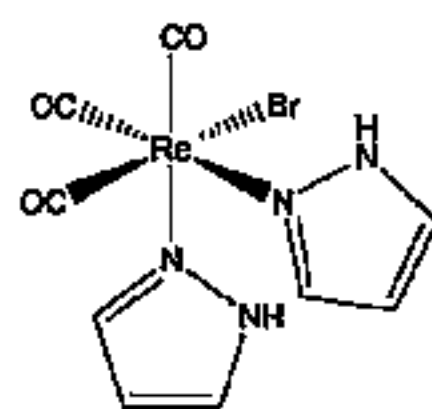

18

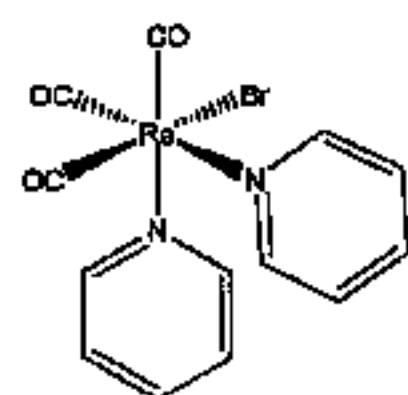

19

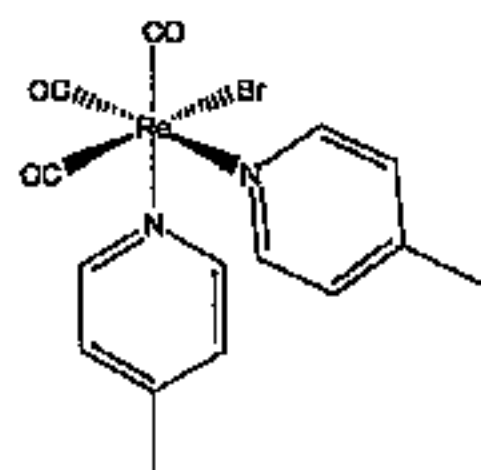

20

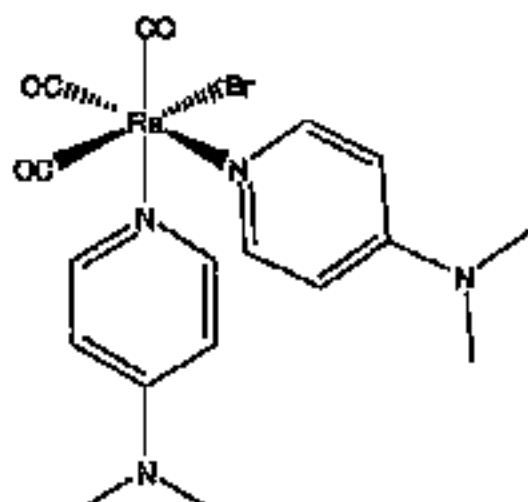

21