

March 19, 1940.

F. ASHWORTH
MOCCASIN LASTING MACHINE

2,193,796

Filed March 22, 1939

2 Sheets-Sheet 1

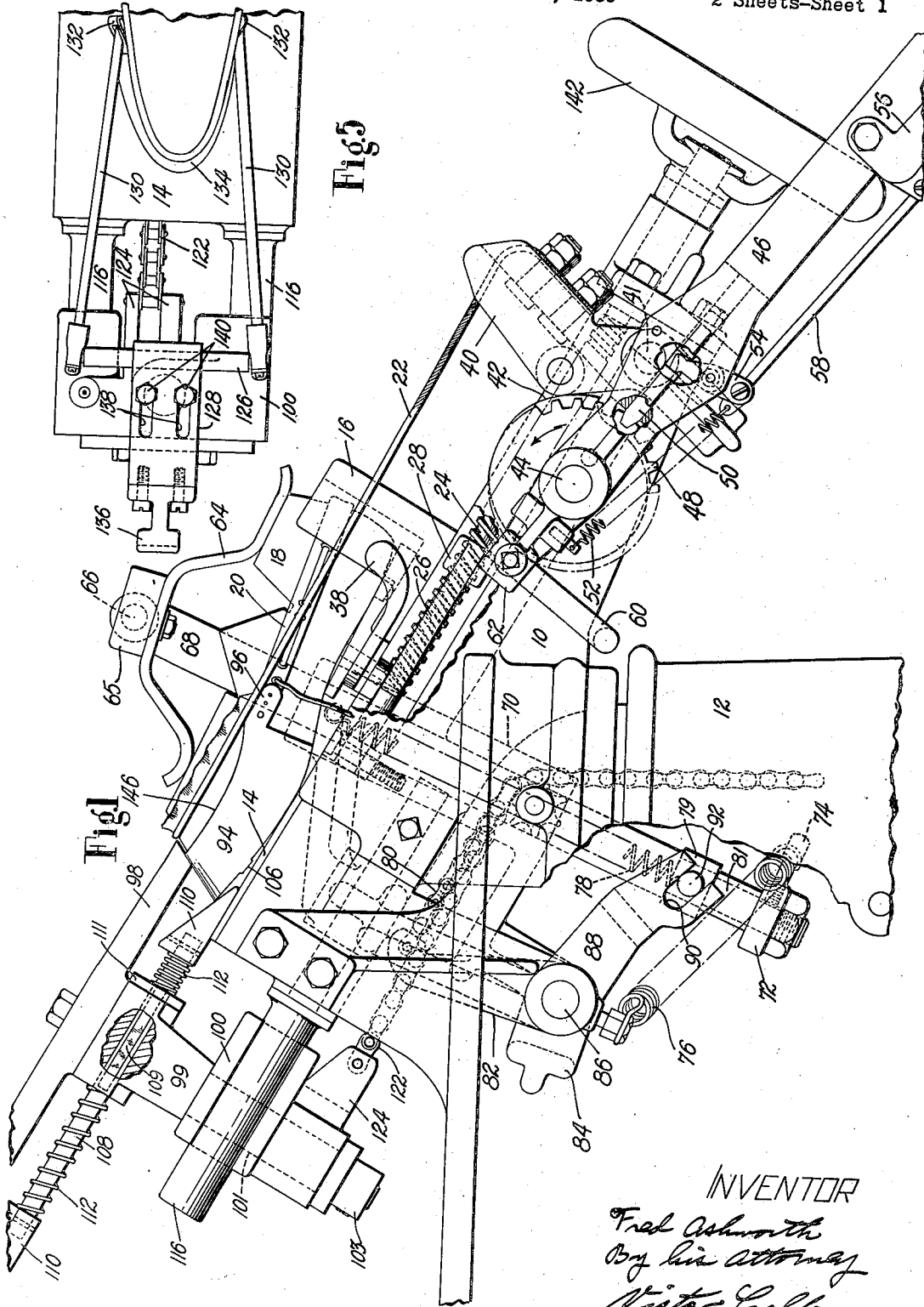

INVENTOR
Fred Ashworth
By his attorney
Victor Cobb.

UNITED STATES PATENT OFFICE

2,193,796

MOCCASIN LASTING MACHINE

Fred Ashworth, Wenham, Mass., assignor to
United Shoe Machinery Corporation, Borough
of Flemington, N. J., a corporation of New
Jersey

Application March 22, 1939, Serial No. 263,454

23 Claims. (Cl. 12-7)

The present invention relates to machines for shaping the foreparts of moccasins over lasts. A machine of this type is illustrated and described in United States Letters Patent No. 2,086,526, granted July 13, 1937, on an application of mine. The machine illustrated in said patent is provided with a flexible forepart lasting member or cable which operates on the forepart of a moccasin bottom on its last, the moccasin bottom being that portion of the moccasin which covers the bottom and the periphery of the foot. In its operation the cable moves upwardly over the periphery of the forepart of the last, which is supported in generally upright position, stretching the forepart of the moccasin bottom and gathering it inwardly against the periphery of the last. After the lasting operation has been completed the cable holds the forepart of the moccasin bottom in lasted position while the moccasin bottom is secured to the last.

It is an object of the invention to provide a moccasin lasting machine of the type above described which is adapted to be employed in practicing a novel method of making moccasins described in an application for United States Letters Patent Serial No. 240,546, filed November 15, 1938, by myself and Corwin W. Baker. In accordance with the method set forth in that application a forepart clamp is applied to the periphery of the forepart of the moccasin bottom after the moccasin bottom has been shaped over the last and the clamp is secured to the last to hold the forepart in lasted position while it is trimmed and a toe piece is attached thereto. In accordance with a feature of the present invention the illustrated machine is provided with means, herein illustrated as a pusher, for operating on a forepart embracing clamp portable with the moccasin bottom and last to urge said clamp into clamping engagement with the forepart. While the illustrated means for operating on a forepart embracing clamp is shown in a machine having a flexible forepart lasting cable, it is to be understood that the invention is not limited in its scope to a clamp operating means embodied in a machine provided with a lasting cable, but could be incorporated in a moccasin lasting machine provided with a different type of lasting mechanism without departing from the invention. In practicing the method set forth in the application above referred to, the upper edge of the forepart clamp is employed as a guide for the forepart trimming knife. With this in view the clamp employed in the practice of said method is provided with inwardly extending tabs which engage

the margin of the sole portion of the moccasin bottom to locate the clamp in a predetermined position heightwise of the last such that the upper edge of the clamp is correctly located for guiding the trimming knife. For insuring the correct positioning of the clamp heightwise of the last the illustrated machine, in accordance with a further feature of the invention, is provided with means for urging the clamp heightwise of the last into the desired position. The illustrated means for urging the clamp heightwise of the last comprises a wedge constructed and arranged to enter the space between the work support and the toe end of the sole portion of the moccasin bottom and to act on the bottom edge of the clamp. The pusher and the wedge operate simultaneously on the clamp in response to the advancement of a carrier to which the pusher is fixed and on which the wedge is so mounted that it can yield in the direction of the length of the last.

For advancing the moccasin bottom on its last into position to be operated upon by the lasting cable the illustrated machine is provided with a work carriage and a hand screw for operating the carriage which are similar in their construction and operation to corresponding parts in the machine illustrated in the patent above referred to. In accordance with a further feature of the invention the hand screw operates in members constructed and arranged to be disengaged from the screw to permit the operator to advance the carriage while the screw remains stationary. This construction enables the operator to effect the greater part of the advancement of the carriage without resorting to the hand screw, thus facilitating the operation of the machine.

These and other features of the invention will now be described with reference to the accompanying drawings and pointed out in the appended claims.

In the drawings:

Fig. 1 is a side elevation of the head of a machine embodying the present invention;

Fig. 2 is a plan view of the machine illustrated in Fig. 1;

Fig. 3 is a detail plan view partly in section illustrating part of the mechanism for operating the work carriage;

Fig. 4 is a detail view in side elevation illustrating the pusher which operates on the forepart embracing clamp; and

Fig. 5 is a plan view illustrating an alternative mechanism for working the forepart embracing

clamp into clamping engagement with the moccasin.

Referring to Fig. 1, the illustrated machine comprises a head 10 mounted on a standard 12 and provided with a work supporting table 14 which inclines upwardly away from the operator, the operator's position being at the right of the machine, as seen in Fig. 1, facing the heel end of a moccasin in the machine. Slidably mounted in the table 14 is a work carriage 16 which receives the heel portion of a last in generally upright position, for example a last 18 illustrated in Fig. 1 on which a moccasin bottom 20 has been assembled. The work carriage 16 is moved in a direction lengthwise of the last to bring the forepart of the moccasin bottom into position to be operated upon by a flexible forepart lasting member herein illustrated as a stranded wire or cable 22. The advancement of the work carriage is divided into two parts, the initial advancement being effected by merely taking hold of the carriage itself and moving it forwardly or to the left, as seen in Fig. 1, until further movement of the carriage is resisted by the engagement of the forepart of the moccasin bottom with the cable. The work carriage is then further advanced by the operation of a hand screw 24 to take up any slack remaining in the cable and to press the forepart of the moccasin bottom firmly into engagement with the cable, the cable engaging the margin of the moccasin bottom along a line as near the bottom of the last as practicable. The hand screw operates on threaded members mounted on the bottom of the work carriage and constructed and arranged to be disengaged from the hand screw in order to permit the initial movement of the work carriage above described. Referring to Figs. 2 and 3, the illustrated screw engaging members comprise arms 26 pivotally mounted on the bottom of the work carriage 16 and provided at their ends nearest the heel end of the last with inwardly extending heads 28 which are concaved and internally threaded, providing a structure resembling a diametrically split nut constructed and arranged for engagement with the hand screw 24. The threaded heads 28 are normally held in operative engagement with the hand screw 24 by a tension spring 30 which operates on a rocker lever 32 pivoted to the bottom of the work carriage 16 and having two upstanding pins 34 which operate in cam slots 36 provided in the arms 26. For disengaging the threaded heads 28 from the hand screw the rocker lever 32 is provided with a thumb lever 33 which is bent so as to position the free end of the lever for convenient engagement by the thumb of the operator's right hand as he grips the work carriage preparatory to its initial advancement, see Fig. 1.

For operating the lasting cable 22 the illustrated machine is provided with mechanism which in its general organization and in many of its details of construction is substantially the same as the cable operating mechanism illustrated and described in my patent above referred to. Referring to Fig. 2, the illustrated machine is provided with two cable carriers 40 on a rock shaft 41 and two cams 42 secured to a shaft 44 and arranged to swing the cable carriers to the right, as seen in Fig. 1, to operate the cable. For operating the cams 42 the illustrated machine is provided with a hand lever 46 which is freely mounted on the shaft 44. Secured to the shaft 44 adjacent to the hand lever 46 is a gear 48

and slidably mounted in the hand lever is a detent 50 which operates on the gear 48 and is constructed and arranged for movement relatively to the gear in a line common to the diameter of the gear. The detent 50 is normally held retracted by a spring 52 (Fig. 1) which operates on a short lever 54 pivoted to the hand lever and constructed and arranged to operate in grooves 55 (Fig. 2) provided in opposite sides of the detent. The detent is operable at the will of the operator by upward movement of an auxiliary lever 56 carried by the hand lever 46 and connected by a link 58 to the short lever 54. In operating the cable 22 the hand lever 46 is moved upwardly, rotating the cams 42 in the direction of the arrow in Fig. 1. When the hand lever is not being operated it is held in the position illustrated in Fig. 1 by a bent rod 60 which is secured to an extension 62 of the hand lever and arranged to engage the machine head.

For holding the last against upward movement during the operation of the cable the illustrated machine is provided with a holddown mechanism which is similar in its construction and operation to a holddown mechanism illustrated and described in United States Letters Patent No. 2,084,326, granted June 22, 1937, on an application of Rene E. Duplessis. Referring to Fig. 1, the illustrated holddown is a bar 64 the forward end of which is bent downwardly for engagement with the upper surface of the forepart of the last and the rear portion of which is bent downwardly and arranged to engage the upper surface of the rear part of the last. The holddown bar is secured to a block 65 swiveled on a rod 66 which in its operative position extends inwardly over the last from the upper end of a shaft 68 extending generally heightwise of the last and mounted in a bearing in a bracket 70 secured to the machine head. On the lower portion of the shaft 68 there is secured a collar 72 to which is secured a screw eye 74 which provides an anchorage for one end of a spring 76 (Fig. 2) the opposite end of which is anchored to a stud extending downwardly from the machine head. The spring 76 operates to maintain the holddown initially in a position remote from the work table 14 and to the left of the shaft 68, as shown in Fig. 2. The holddown is yieldingly held at the limit of its upward movement by a spring 78 the lower end of which is anchored to a square block 79 loosely mounted on the shaft 68 and the upper end of which is anchored to the bracket 70. The block 79 is confined between a shoulder on the shaft 68 and a spacer 81 mounted on the shaft. The holddown is moved downwardly into engagement with the last by the operation of a treadle (not shown) which is connected by a chain 80 to an arm 82 which is the upstanding member of a rocker 84 carried by a cross shaft 86 mounted in brackets extending downwardly from the machine head, the other element of said rocker being an arm 88 which is provided at its free end with a yoke which engages opposite sides of the square block 79 and holds it from turning with the shaft 68. The arm 88 acts on studs 92 in the square block 79, each arm of the yoke being provided with an open-ended slot 90 (Fig. 1) which receives one of said studs. The rocker 84 is swung in a clockwise direction, as seen in Fig. 1, by the operation of the holddown treadle, thus imparting downward movement to the shaft 68 and bringing the holddown bar 64 into engagement with

the last, in which position it is held by a treadle latch (not shown).

For holding the forepart of the moccasin bottom in latched position a forepart clamp is provided. This clamp is first brought into clamping engagement with the forepart of the moccasin bottom by mechanism now to be described and is then secured to the last in any suitable manner,—for example a forepart clamp 94 illustrated in Fig. 1 has rearwardly extending perforated tabs 96 through which tacks are driven to secure the clamp to the last. For bringing the clamp 94 forcibly into engagement with the toe end of the moccasin bottom the illustrated machine is provided with a pusher shown herein as a rigid bar 98 which is secured midway between its ends to a swivel block 99. The swivel block has a stem 101 which extends downwardly into a bore in a carrier 100 and is held against upward movement by a collar 103 secured to its lower end. Referring to Fig. 4, the bar 98 has a beveled work engaging surface 102 at one end for use in lasting men's moccasins and at its opposite end the bar 98 has a beveled face 104 which is downwardly offset from the surface 102 to arrange it to operate on small size moccasins. The clamp 94 is provided with inwardly extending tabs one of which is illustrated at 106 in Fig. 1, which tabs serve to position the clamp heightwise of the moccasin bottom. In order to force the clamp 94 upwardly to bring the tabs firmly into engagement with the sole portion of the moccasin bottom, thus to locate the clamp heightwise of the moccasin bottom, the illustrated machine is provided with a slide rod 108 which is mounted in a bore in the swivel block 99 and has secured to each end a lifter or wedge 110 the bottom surface of which is constructed and arranged to lie flat against the work table 14 while the upper surface is arranged to engage and lift the clamp member as the wedge moves toward the heel end of the last. For holding the slide rod 108 against turning movement in the swivel block 99 it is slabbed off at opposite sides thereof along a section of the rod which extends through the swivel block, as illustrated at 109 in Fig. 1. This slabbed off portion of the slide rod slides through an opening in a plate 111 secured to the swivel block 99, said opening having straight side walls which engage the slabbed off portions of the slide rod and hold said rod against turning movement in the swivel block. The wedges 110 are spaced from the swivel block 99 by two springs 112 on the slide rod 108. During the advancement of the carrier 100 one wedge 110 engages the clamp 94 while the pusher bar 98 is still spaced therefrom and as the carrier completes its advancement and brings the pusher bar forcibly against the clamp 94 one of the springs 112 is compressed and acts on the wedge 110 to force it into the space between the table and the bottom of the toe end of the clamp, thereby forcing the clamp upwardly until the tabs 106 provided on the clamp are brought forcibly into engagement with the sole portion of the moccasin bottom. For mounting the pusher carrier 100 fixed parallel bars 116 (Fig. 2) extend through bearings or heads 114 at opposite sides of the carrier. For yieldingly holding the carrier 100 in its retracted position a compression spring 118 is mounted in a longitudinal bore in each bar 116. The springs 118 act on a crossbar 120 secured to the carrier 100, the inner walls of the parallel bars 116 being provided with slots through which the end portions of the crossbar extend into the interior of said parallel bars. The carrier 100 is

advanced to operate the pusher bar 98 and one of the wedges 110 by the depression of a treadle (not shown) which is connected by a chain 122 (Fig. 1) to lugs 124 on the lower portion of the carrier.

In Fig. 5 there is illustrated an alternative mechanism for working the forepart clamp into clamping engagement with the forepart of the moccasin bottom. This mechanism, which may be mounted on a swivel block similar to the swivel block 99, comprises a crossbar 126 which is secured in a plate 128 on the swivel block and carries at its outer ends two push rods 130, ball and socket connections being provided between the crossbar and the push rods to permit the push rods to swing in any direction. The free ends of the push rods are rounded for engagement within hollow brackets 132 extending outwardly from opposite ends of a forepart clamp 134. At its end opposite the crossbar 126 the plate 128 carries a pusher member 136 which, when the swivel block is reversed from its position in Fig. 5, is arranged to operate on the forepart clamp in the same manner as the pusher bar 98 illustrated in Fig. 1. In order to permit the push rods 130 to be adjusted lengthwise of the last for operation on clamps of different sizes parallel slots 138 are provided in the plate 128 through which slots extend screws 140 which secure the plate to the swivel block.

In the operation of the illustrated machine a last with a moccasin bottom assembled thereon is arranged in generally upright position with its forepart resting on the work table 14 and its rear part supported in the carriage 16. The moccasin bottom is tacked to the last in the region of the back seam but the forepart is not attached to the last but lies substantially flat on the work table. With the fingers of one hand the operator gathers the margin of the moccasin bottom in against the periphery of the last while with the other hand he grips the carriage 16 and advances it to bring the upturned margin of the forepart of the moccasin bottom into engagement with the forepart lasting cable 22. Preferably the operator will grip the work carriage with his right hand and in so doing will engage the thumb lever 38 and disengage the internally threaded heads 28 (Fig. 3) of the arms 26 from the hand screw 24 in order to permit the carriage to be moved freely in its guideway. The cable 22 is arranged to engage the forepart of the moccasin bottom as near the sole portion of the last as practicable. The upturned margin of the moccasin bottom will in most cases extend only about one-half an inch above the cable since the moccasin bottom has not been stretched over the last prior to the operation of the illustrated machine. After the operator has advanced the work carriage 16 as above described sufficiently to take most of the slack out of the cable he releases his grip on the work carriage, permitting the arms 26 to return the internally threaded heads 28 to their position of engagement with the hand screw 24, and thereupon the operator turns the hand wheel 142 at the end of the hand screw 24, thereby further advancing the work carriage 16, thus taking the remaining slack out of the lasting cable and forcing the moccasin bottom firmly into the loop of the cable. After the holddown bar 64 has been brought into engagement with the top of the last as illustrated in Fig. 1, the forepart of the moccasin bottom is latched by drawing the cable rearwardly by means of the cable operating mechanism hereinbefore described. As the cable moves

rearwardly it travels up the incline of the periphery of the forepart of the last 18 carrying the forepart of the moccasin bottom with it and stretching and shaping the forepart about the last. Preferably, and as herein illustrated, the moccasin bottom is mounted on a special last such as that illustrated and described in the application for United States Letters Patent before referred to. The peripheral surface of the forepart of the illustrated last has a uniform gradient which facilitates the operation of the lasting cable and the forepart of the last is so constructed that the cable is in gripping engagement with the entire forepart of the moccasin bottom in all stages of its operation. After the lasting operation has been completed the operator inspects the work and if necessary pulls up the sides of the forepart with hand pincers. A clamp such, for example, as the clamp 34 illustrated in Fig. 1, is then applied to the forepart of the moccasin bottom and the pusher bar 92 and wedge 110 are operated to bring the clamp into clamping engagement with the moccasin bottom and into predetermined position heightwise of the moccasin bottom. The clamp is then secured to the last and remains with the last while the forepart is trimmed. After the clamp has been secured to the last the pusher 92 is returned to its rest position and the tension of the lasting cable is released by downward movement of the cable operating hand lever 46. After the tension of the cable has been sufficiently released to permit the cross shaft 44 to turn freely the operator completes the return movement of the cable by turning the knurled knob 144 (Fig. 2) secured to the cross shaft. Preferably the upper edge 146 of the clamp 94 serves as a guide for the trimming knife. After the forepart has been trimmed the clamp may be removed and the last pulled and a toe piece secured to the forepart of the moccasin bottom. I have found, however, that better results are obtained by employing a method set forth in the application above referred to. In accordance with this method the clamp 94 remains on the last after the trimming operation, and the upper portion of the forepart of the last which, as illustrated in said application, is separate from the body portion of the last, is removed to permit a toe piece to be attached to the moccasin bottom while the forepart of the moccasin bottom is still held against the last by the clamp.

Having thus described my invention, what I claim as new and desire to secure by Letters Patent of the United States is:

1. In a machine for shaping moccasins over lasts, the combination with a support for a last with a moccasin bottom thereon, and forepart lasting means, of means other than said forepart lasting means for operating on a forepart-embracing clamp portable with the moccasin bottom and last to urge said clamp into clamping engagement with the forepart.

2. In a machine for shaping moccasins over lasts, the combination with a support for a last with a moccasin bottom thereon, and forepart lasting means, of a pusher constructed and arranged to operate on a forepart-embracing clamp portable with the moccasin bottom and last to force said clamp into clamping engagement with the forepart.

3. In a machine for shaping moccasins over lasts the combination with a support for a last with a moccasin bottom thereon, and forepart lasting means, of means constructed and ar-

ranged to move a forepart-embracing clamp heightwise of the last into proper position to clamp the forepart against the last.

4. In a machine for shaping moccasins over lasts, the combination with a support for a last with a moccasin bottom thereon, and forepart lasting means, of a lifter for bringing a forepart-embracing clamp into a predetermined position heightwise of the last.

5. In a machine for shaping moccasins over lasts, the combination with a support for a last in generally upright position with a moccasin bottom thereon, and forepart lasting means, of a wedge constructed and arranged to enter the space between the support and the toe end of the moccasin bottom and to urge a forepart-embracing clamp heightwise of the last.

6. In a machine for shaping moccasins over lasts, the combination with a support for a last with a moccasin bottom thereon, and forepart lasting means, of a member for working a forepart clamp into clamping engagement with the forepart of the moccasin bottom, and another member for urging said clamp heightwise of the last.

7. In a machine for shaping moccasins over lasts, the combination with a support for a last in generally upright position with a moccasin bottom thereon, and forepart lasting means, of a pusher for forcing a forepart clamp into clamping engagement with the moccasin bottom, and a lifter for positioning the clamp heightwise of the last.

8. In a machine for shaping moccasins over lasts, a table for supporting a last in generally upright position with a moccasin bottom thereon, means constructed and arranged to operate on a forepart-embracing clamp to urge said clamp into clamping engagement with the forepart, and a wedge constructed and arranged to enter a space between the table and the sole portion of the moccasin bottom and to urge said clamp heightwise of the last.

9. In a machine for shaping moccasins over lasts, a table for supporting a last in generally upright position with a moccasin bottom thereon, means constructed and arranged to operate on a portable forepart-embracing clamp to urge said clamp into clamping engagement with the forepart, a wedge constructed and arranged to enter a space between the table and the sole portion of the moccasin bottom and to urge said clamp heightwise of the last, and a holddown for holding the last and moccasin bottom against the table.

10. In a machine for shaping moccasins over lasts, a table for supporting a last in generally upright position with a moccasin bottom thereon, a member constructed and arranged to engage a forepart clamp which engages the periphery and the sole portion of the moccasin bottom and to urge said clamp lengthwise of the last against the toe end of the moccasin bottom, and a wedge constructed and arranged to enter a space between the table and the sole portion of the moccasin bottom at its toe end and to urge said clamp against the sole portion of the moccasin bottom.

11. In a machine for shaping moccasins over lasts, the combination with a support for a last with a moccasin bottom thereon, and forepart lasting means, of a pusher for forcing a forepart clamp into clamping engagement with the moccasin bottom, a member constructed and arranged to engage said clamp and to position it

heightwise of the last, and a carrier for the pusher and said positioning member.

12. In a machine for shaping moccasins over lasts, the combination with a support for a last with a moccasin bottom thereon, and forepart lasting means, of a pusher for forcing a forepart clamp into clamping engagement with the moccasin bottom, a member constructed and arranged to engage said clamp and to position it heightwise of the last, and a carrier for the pusher and said positioning member, said carrier being mounted for rectilinear movement toward and from the toe end of the last.

13. In a machine for shaping moccasins over lasts, the combination with a support for a last with a moccasin bottom thereon, and forepart lasting means, of a pusher for forcing a forepart clamp into clamping engagement with the moccasin bottom, and a carrier for the pusher, said carrier being mounted for rectilinear movement toward and from the toe end of the last.

14. In a machine for shaping moccasins over lasts, the combination with a support for a last with a moccasin bottom thereon, and forepart lasting means, of a reversible pusher the ends of which are in different positions heightwise of the last, said pusher being arranged to force a forepart clamp into clamping engagement with the moccasin bottom, a carrier for the pusher, and means for moving the carrier toward the toe end of the last.

15. In a machine for shaping moccasins over lasts, a table for supporting a last in generally upright position with a moccasin bottom thereon, a pusher constructed and arranged to engage a forepart clamp which engages the periphery and the sole portion of the moccasin bottom and to urge said clamp lengthwise of the last against the toe end of the moccasin bottom, a wedge constructed and arranged to enter a space between the table and the sole portion of the moccasin bottom at its toe end and to urge said clamp against the sole portion of the moccasin bottom, a carrier to which the pusher is fixed and on which the wedge is so mounted that it can yield in the direction of the length of the last, and means for moving the carrier toward the toe end of the moccasin bottom.

16. In a machine for shaping moccasins over lasts, the combination with a support for a last with a moccasin bottom thereon, and a forepart lasting member, of means for working a forepart clamp into clamping engagement with the forepart of the moccasin bottom, means for urging said clamp heightwise of the last, and operating mechanism constructed and arranged to render said last-mentioned means effective and thereafter to render said first-mentioned means effective.

17. In a machine for shaping moccasins over lasts, the combination with a support for a last with a moccasin bottom thereon, and forepart lasting means, of a pusher for forcing a forepart clamp into clamping engagement with the moccasin bottom, a member constructed and arranged to engage said clamp and to position it heightwise of the last, and a carrier for the pusher and said positioning member, said carrier being constructed and arranged for rectilinear movement toward and from the toe end of the last, said pusher and said member being so arranged rela-

tively to each other on the carrier that said member engages the clamp and positions it heightwise of the last before the pusher engages the clamp.

18. In a machine for shaping moccasins over lasts, the combination with a support for a last with a moccasin bottom thereon, and forepart lasting means, of means for working a forepart clamp into forepart-embracing and clamping position including a pair of members constructed and arranged to operate on opposite end portions of said clamp.

19. In a machine for shaping moccasins over lasts, means for working a forepart clamp into forepart-embracing and clamping position comprising a pair of push rods constructed and arranged to operate on opposite end portions of the clamp, a carrier for the push rods, and means for moving the carrier toward the toe end of a moccasin on the last thereby to operate said push rods.

20. In a machine for shaping moccasins over lasts, the combination with a support for a last with a moccasin bottom thereon, and forepart lasting means, of mechanism for operating said lasting means including a lever, a locking member on the lever for rendering the lever effective, means for holding the locking member normally in retracted position, and means on the lever for rendering said locking member effective.

21. In a machine for shaping moccasins over lasts, the combination with a support for a last with a moccasin bottom thereon, and forepart lasting means, of a cam for operating the lasting means, a hand lever for operating the cam, a locking member for rendering the hand lever effective, means operating on the locking member to hold it normally in retracted position, and an auxiliary means on the hand lever for rendering said locking member effective.

22. In a machine for shaping moccasins over lasts, forepart lasting means, a work carriage constructed and arranged for movement to position the work relatively to the forepart lasting means, a screw for moving the carriage to bring the work forcibly into engagement with the forepart lasting means, and screw engaging means on the carriage constructed and arranged to be disengaged from the screw to permit the operator to advance the carriage while the screw remains stationary.

23. In a machine for shaping moccasins over lasts, the combination with a flexible forepart lasting cable constructed and arranged to extend rearwardly of a last in the machine along both sides of the last and beyond its heel end, and an operating means to which the ends of the cable are anchored, of a work carriage constructed and arranged for movement to position the work relatively to the forepart lasting cable, a screw for moving the carriage to bring the work forcibly against the cable and to tension the cable about the work, screw engaging means on the carriage comprising two internally threaded members which in their operative positions mesh with the screw, and means operable at the will of the operator to disengage said members from the screw to permit the operator to bring the work into engagement with the cable while the screw remains stationary.

FRED ASHWORTH.