

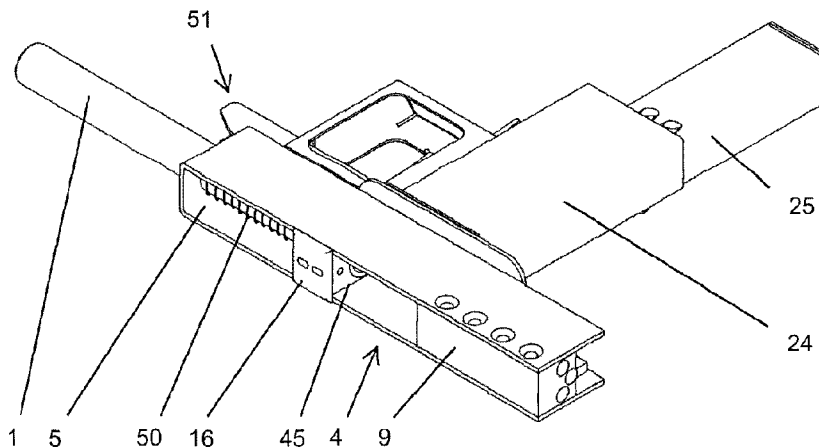

(22) Date de dépôt/Filing Date: 2015/06/25  
 (41) Mise à la disp. pub./Open to Public Insp.: 2015/12/26  
 (45) Date de délivrance/Issue Date: 2022/02/22  
 (30) Priorité/Priority: 2014/06/26 (AT A 507/2014)

(51) Cl.Int./Int.Cl. *F41A 3/26* (2006.01),  
*F41A 3/66* (2006.01)  
 (72) Inventeur/Inventor:  
CONLE, HENNING, CH  
 (73) Propriétaire/Owner:  
CONLE, HENNING, CH  
 (74) Agent: BORDEN LADNER GERVAIS LLP

(54) Titre : ARME DE POING  
 (54) Title: HANDGUN



(57) Abrégé/Abstract:

In the case of a fully automatic handgun having a barrel (1) and a blowback open bolt firing breech mechanism, which is mounted in a displaceable manner on a guide (45), the blowback breech mechanism has a slide with an essentially U-shaped bracket (5), on which a breechblock (9) is arranged. The slide is mounted in a displaceable manner on the guide (45) and on the barrel (1).

**Abstract**

In the case of a fully automatic handgun having a barrel (1) and a blowback open bolt firing breech mechanism, which is  
5 mounted in a displaceable manner on a guide (45), the blowback breech mechanism has a slide with an essentially U-shaped bracket (5), on which a breechblock (9) is arranged. The slide is mounted in a displaceable manner on the guide (45) and on the barrel (1).

**HANDGUN**

The invention relates to a fully automatic handgun having a barrel and a blowback open bolt firing breech mechanism, which is mounted in a displaceable manner on a guide.

The weapon according to the invention is constructed in accordance with the known principle of a blowback open bolt breech firing mechanism. In the case of a ready-to-fire weapon, there is no cartridge in the chamber and the breech mechanism is secured in a rear position. By virtue of the trigger being activated, the breech mechanism is freed and moved forward, in the direction of the barrel, by a spring. In the process, it carries along a cartridge out of the magazine, pushes it into the chamber and ignites it as a result of the impact of the firing pin on the primer of the cartridge. As a result of the mass inertia, the breech mechanism secures the cartridge case in the chamber essentially until the bullet has left the barrel. The cartridge case and the breech mechanism are then moved rearwards by the chamber pressure until the breech mechanism, when pressure on the trigger has been released, is arrested again. The cartridge case is ejected during the return movement. If the trigger remains pulled, this operation is repeated as long as there is ammunition present.

It is desirable to create such a weapon which can be produced in as straightforward and advantageous a manner as possible.

In one aspect, the invention provides a handgun of the type mentioned in the introduction, in that the blockback breech mechanism has a slide with an essentially U-shaped bracket, on which a breechblock is arranged, and in that the slide is

mounted in a displaceable manner on the guide and on the barrel.

Further features and advantages of the invention can be gathered from the following description of a preferred exemplary embodiment of the invention, with reference to the attached drawings, in which (not to scale):

10 fig. 1 shows a side view of a preferred embodiment of a handgun according to the invention,

fig. 2 shows the handgun in an oblique view,

15 fig. 3 shows the handgun in an oblique view as seen from a different perspective,

fig. 4 shows a U-shaped bracket of the handgun,

20 fig. 5 shows a barrel of the handgun,

figs. 6a and 6b show a magazine well of the handgun,

figs. 7a and 7b show a barrel holder of the handgun,

25 fig. 8 shows a carrier plate of the handgun,

fig. 9 shows a locking part of the handgun,

30 fig. 10 shows a wall element of the magazine well of the handgun,

figs. 11a and 11b show a breechblock of the handgun,

figs. 12a and 12b show a guide of the handgun,

fig. 13 shows a catch of the handgun,  
fig. 14a and 14b show a trigger of the handgun,  
5 fig. 15 shows a safety bracket of the handgun,  
fig. 16 shows a locking lever of the handgun, and  
10 figs. 17a and 17b show a firing pin of the handgun.

An embodiment of the handgun according to the invention which is illustrated in the drawings has a barrel 1, of which the chamber end 2 is fastened on a barrel holder 3. A breech  
15 mechanism 4, which is configured in the manner of a blowback breech mechanism, essentially comprises a bracket 5 which is bent in a U-shaped manner and has two legs 6 and a base 7, which connects the legs. The base 7 has an opening 8, through which the barrel 1 is guided. A breechblock 9 is fastened at  
20 the free ends of the legs 6. The breechblock 9 is preferably screwed to the legs 6, but can also be fastened thereon in some other manner, e.g. by riveting or welding. For screw connection, the ends of the legs have countersunk holes 10 and the breechblock 9 has threaded bores 11, into which  
25 countersunk screws can be screwed in through the countersunk holes 10. The bracket 5 can easily be produced by virtue of being punched out of the metal sheet and bent.

In the embodiment illustrated, the barrel holder 3 (figs. 7a  
30 and 7b) comprises a quadrilateral tube, of which the opposite walls 12, 13 have bores 31a, 31b, in which the chamber end 2 of the barrel 1 can be accommodated. A depression 14 is provided at the chamber end 2 of the barrel 1 (fig. 5) and, when the barrel 1 is in the installed position, said

depression is oriented towards the upper end 15 of the barrel holder 3 and is arranged in the interior of the barrel holder 3.

5 A locking part 16 (fig. 9) comprises a cuboidal block 17, which is plugged into the end 15 of the barrel holder 3. On its underside 18, the locking part has an aperture 19, of which the curvature corresponds to the external diameter of the chamber end 2 of the barrel 1. The depth of the aperture  
10 19 on the locking part 16 corresponds approximately to the depth of the aperture 14 on the barrel 1, and the remaining length L1 on the underside 18 of the locking part 16 is essentially equal to the length L2 of the aperture on the  
15 the resulting protrusion 20, in the aperture 14 on the barrel 1 and fixes the latter both axially and in the circumferential direction.

In order to fasten the locking part 16, a bore 21 is provided  
20 therein, and bores 22 are likewise provided in the walls 12, 13 of the barrel holder 1, it being possible for a locking pin to be plugged through said bores. The locking pin can be secured for its part, for example, by grub screws in bores 23 on the locking part 16.

25 The weapon according to the invention has a magazine well 24 (figs. 6a and 6b), in which a box magazine 25 which is known per se is accommodated, as is known per se, in a releasable manner. The magazine well 24, which, at the same time, can  
30 form a handle, but may also be enclosed by a casing, e.g. made of wood or plastics material, in order for carrying, holding and shooting comfort to be enhanced, can likewise easily be produced by virtue of being punched out of the metal sheet and bent, and it is U-shaped with two side walls 26, 27 and a rear

wall 28. The fourth wall is formed by a U-shaped wall element 86 (fig. 10), which is inserted between the side walls 26, 27 and of which the side walls 79, 80 are connected, e.g. spot welded, to the side walls 26, 27.

5

Two lugs 29, 30, which are bent outward at right angles, are located at the upper ends of the side walls 26, 27 of the magazine well 24. An aperture 56 with two outwardly bent lugs 57 for bearing a locking lever 81 (fig. 16) is provided in one  
10 wall 26.

A carrier plate 32 (fig. 8), which is preferably likewise produced by virtue of being punched out of the metal sheet, is U-shaped with two legs 33, 34, by way of which it is fastened  
15 on, e.g. welded to, the lugs 29, 30 of the magazine well 24. The base 35 of the carrier plate 32 has two bores 36, 37, through which a guide 38 for the breechblock 9 can be screwed to the carrier plate 32. In the embodiment illustrated, the guide 38 (figs. 12a and 12b) is a solid, cuboidal block with  
20 two threaded bores 39, 40, the positioning of which corresponds to that of the bores 36, 37 on the carrier plate. On the upper side, which is located opposite the carrier plate 38, a cuboidal block has a guide groove 41, in which a crosspiece 42 on the underside of the breechblock 9 can be  
25 displaced.

The breechblock 9 also has arranged on it a recessed breech face 43 and a fixed, possibly interchangeable, firing pin 44 (figs. 17a and 17b). The firing pin 44 may be interchangeable,  
30 for which purpose, for example, two spare mounts 85 may be provided in the breechblock 9.

The legs 6 of the U-shaped bracket 5 are guided such that they can be displaced in a longitudinal direction on a respective

guide 45 on opposite sides of the barrel holder, which is essentially U-shaped. The base of the U shape is formed in each case by one of the mutually opposite walls 46, 47 of the barrel holder 3. The side walls of the U-shaped guides are formed by upper and lower protrusions. The upper protrusions 48, 49 are formed by a projecting periphery on the locking part 16 and the lower protrusions are formed by the legs 33, 34 of the carrier plate 32.

10 The slide, comprising the U-shaped bracket 5 and the breechblock 9, is thus guided in three ways, that is to say by way of the opening 8 on the bracket 5, by the legs 6 on the barrel holder 3 and by the crosspiece 42 on the guide part 38. The slide is pushed forward by a compression spring 50, which is clamped in between the barrel holder 3 and the base 7 of the bracket 8 and encloses the barrel 1.

In its rear position, which is illustrated in figs. 1 to 3, the slide is retained by a catch 51, which is illustrated in 20 fig. 13 and preferably comprises a punched sheet-metal part, which has been bent in a U-shaped manner, and two legs 52, 53 and a base 54. Latching hooks 55a, 55b are arranged at the ends of the legs 52, 53 of the catch 51 and act on the base 7 of the U-shaped bracket 5. The free ends of the legs 52, 53, 25 for reasons relating to stability, may be connected to one another. The catch 51 can be pivoted about an axis 58, which are defined by bores 59, 60 in the legs 52, 53.

A trigger 61 (figs. 14a and 14b), which likewise preferably 30 comprises a punched sheet-metal part which has been bent in a U-shaped manner, has, in two legs 62, 63, bores 64, 65, which likewise define a pivot axis which, in the installed state, coincides with the axis 58 of the catch and is formed by a

common bolt. The trigger 61 is somewhat narrower than the catch 51 and is accommodated between the legs 52, 53 thereof.

The two legs 62, 63 of the trigger 61 have abutment surfaces  
5 66, 67, by way of which they butt against a lower edge 68 of  
the base 54 of the catch 51 when the trigger 61 is pulled, as  
a result of which the catch 51 is pivoted in a  
counterclockwise direction in fig. 1 and the slide 4 is freed,  
in which case the latter, accelerated by the force of the  
10 spring 50, is moved forward in the direction of the barrel 1.

During this process, the crosspiece 42 pushes a cartridge out  
of the magazine 25 and introduces it into the chamber. As soon  
as the breechblock 9 is right in its forward position, the  
15 cartridge is ignited by the firing pin 44, whereupon the slide  
is moved back again by the cartridge under the action of the  
chamber pressure. The catch 51 is subjected to loading in the  
clockwise direction by a spring (not illustrated) and moves in  
this direction as soon as pressure on the trigger 61 is  
20 released. During the return movement of the slide, the  
cartridge strikes against the guide 38 and is thus ejected  
upward.

A safety bracket 69 is provided in order to prevent a shot  
25 from being fired unintentionally, said safety bracket likewise  
preferably comprising a punched sheet-metal part which has  
been bent in a U-shaped manner, and being mounted such that it  
can be pivoted about an axis 70. The legs 71, 72 of the safety  
bracket have hooks 73, 74, which act on the upper edge 75 of  
30 the base 54 of the catch 51 when the safety bracket 69 is  
located in its basic position, into which it is pushed in the  
clockwise direction by a spring (not illustrated).

The handle part 76 of the safety bracket 69 is located within the trigger 61, and in extension thereof, and is supported laterally, by way of protrusions 90, 91, on the side walls 46, 47 of the barrel holder 3. Since, when it is not subjected to pushing action, the safety bracket 69 blocks the catch 51, the catch 51 and thus also the slide are secured should the trigger be pulled unintentionally or the weapon be subjected to such pronounced impact that the catch 51 unlocks. If, however, the safety bracket 69 is subjected to pushing action at the same time, it can be assumed that the user is holding the weapon sufficiently firmly in his hand and is intending to shoot.

In the case of the barrel holder 3 (figs. 7a and 7b), the one wall 13 of the profile tube has been removed over approximately 2/3 of the length and pairs of bores 77, 78 are provided in the two adjacent walls 46, 47, the bolts running along the axes 58 and 70 of the catch 51 and of the trigger 61, and/or of the safety bracket 69, being plugged through said bores. This makes it possible to form a trigger assembly 89 which is easy to install and remove.

The locking lever 81 according to figure 16 is likewise preferably produced from a punched sheet-metal part which has been bent in a U-shaped manner, and it has a base 82 and side walls 83, 84, of which the corners 87, 88 engage in an aperture in a wall of the magazine 25.

**CLAIMS:**

1. An automatic handgun, comprising:

a barrel;

a blowback breech mechanism having a slide with a substantially U-shaped bracket and a breechblock disposed on said U-shaped bracket;

said U-shaped bracket being formed of an angled metal sheet, said U-shaped bracket being a part having been punched out of a metal sheet and bent;

said U-shaped bracket having legs with free ends, said legs being aligned substantially parallel with an axis of said barrel;

said breechblock being accommodated between said legs at said free ends of said legs and said breechblock being affixed thereto; and

said slide being mounted for displacement on a guide and on said barrel, and said slide being open on an upper side and a lower side.

2. The handgun according to claim 1, which comprises a compression spring disposed to enclose said barrel and clamped in between said U-shaped bracket and said guide.

3. The handgun according to claim 1, wherein said guide is arranged on a trigger assembly.

4. The handgun according to claim 1, wherein said barrel projects through an opening formed in a base of said U-shaped bracket.

5. The handgun according to claim 1, wherein said guide is formed with two mutually opposite U-shaped depressions, and said legs of said U-shaped bracket are guided in said depressions.

6. The handgun according to claim 5, wherein said guide is arranged on a barrel holder, and said barrel is releasably fastened on said barrel holder.

7. The handgun according to claim 6, wherein said barrel holder is substantially cuboidal in a guide region and said U-shaped depressions are delimited by protrusions disposed thereon.

8. The handgun according to claim 7, wherein a pair of protrusions are disposed on a locking part, said locking part is fastened at an end of said barrel holder, and said locking part engages in a depression on said barrel.

9. The handgun according to claim 6, wherein said barrel holder comprises a rectangular profile tube with two openings in opposite walls, through which said barrel projects transversely to a longitudinal direction of said profile tube.

10. The handgun according to claim 9, which comprises a locking part plugged into an end of said profile tube and fastened there.

11. The handgun according to claim 1, further comprising a magazine well and a carrier plate disposed on said magazine

well, and a second guide for said slide fastened at said carrier plate.

12. The handgun according to claim 11, wherein said carrier plate is formed with a pair of protrusions.

13. The handgun according to claim 11, which comprises a barrel holder fastened on said magazine well.

14. The handgun according to claim 11, which comprises a pivotably mounted catch arranged on said magazine well acting on a base of said U-shaped bracket.

15. The handgun according to claim 14, wherein said catch is bent substantially in a U-shape and has two legs, at the ends of which latching hooks are arranged, and wherein a trigger, which is mounted along a same axis as the catch, acts on a base that connects said two legs.

16. The handgun according to claim 15, wherein a pivotally mounted safety bracket acts on said base, on a side opposite said trigger, and wherein a handle part of said safety bracket extends past said trigger.

17. The handgun according to claim 16, wherein said catch, said trigger and said safety bracket are mounted on said barrel holder.

18. The handgun according to claim 17, wherein said trigger forms a part of a trigger assembly fastened on said magazine well.

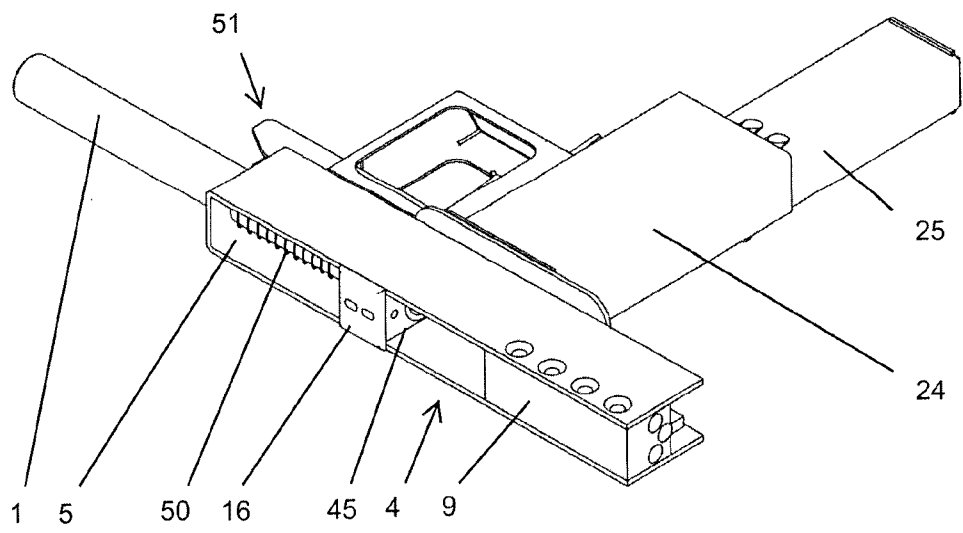
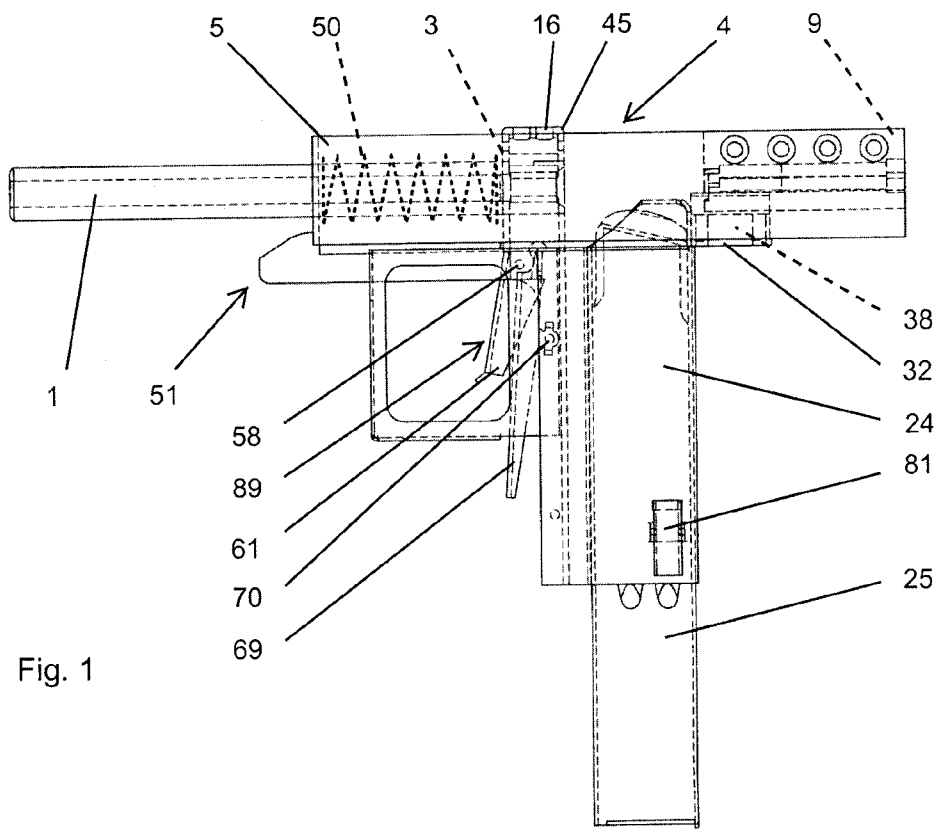

Fig. 3

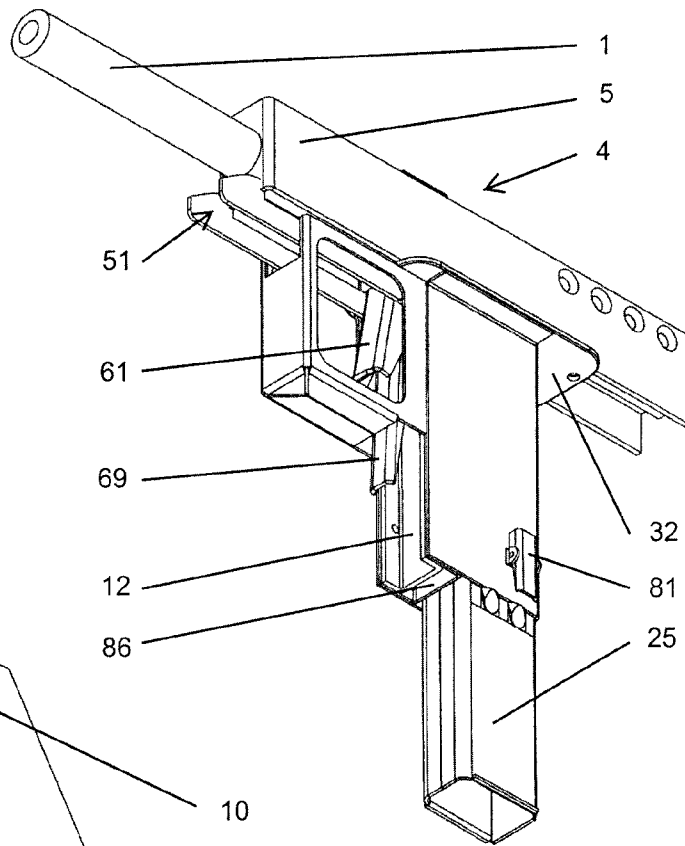
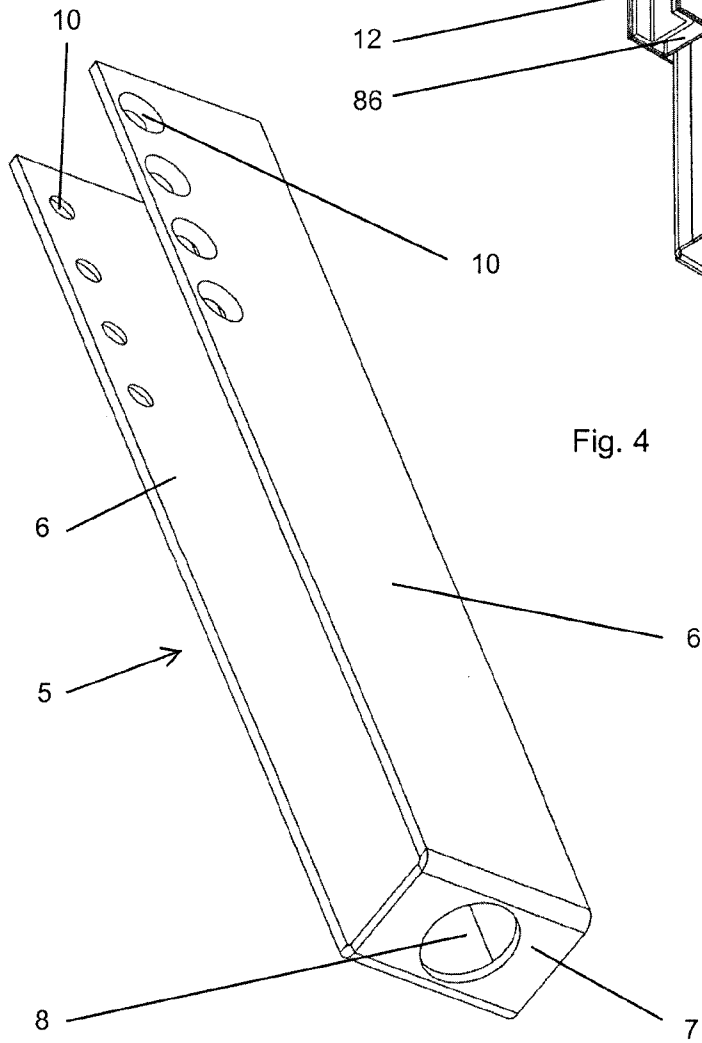

Fig. 4



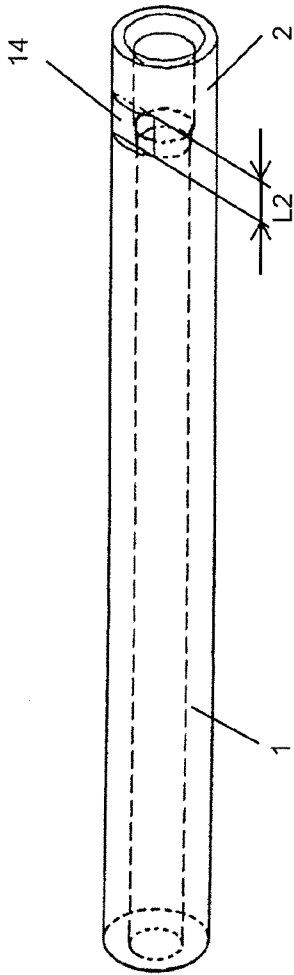

Fig. 5

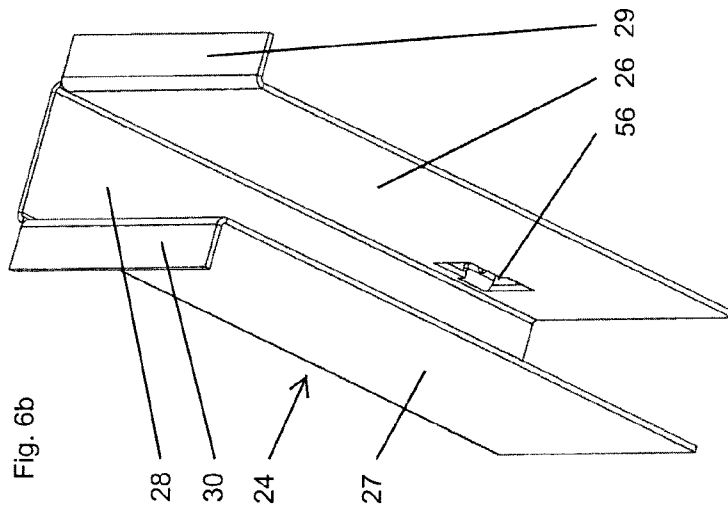

Fig. 6b

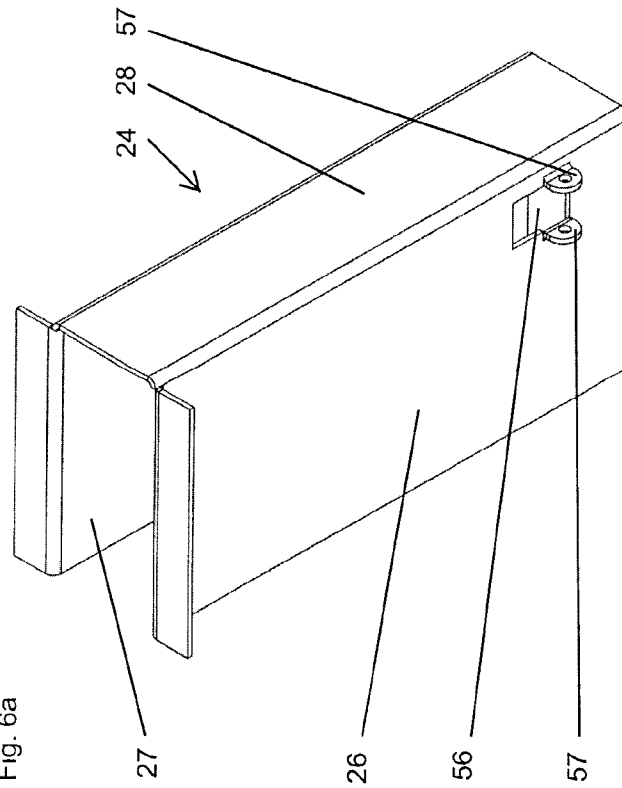

Fig. 6a

Fig. 7a

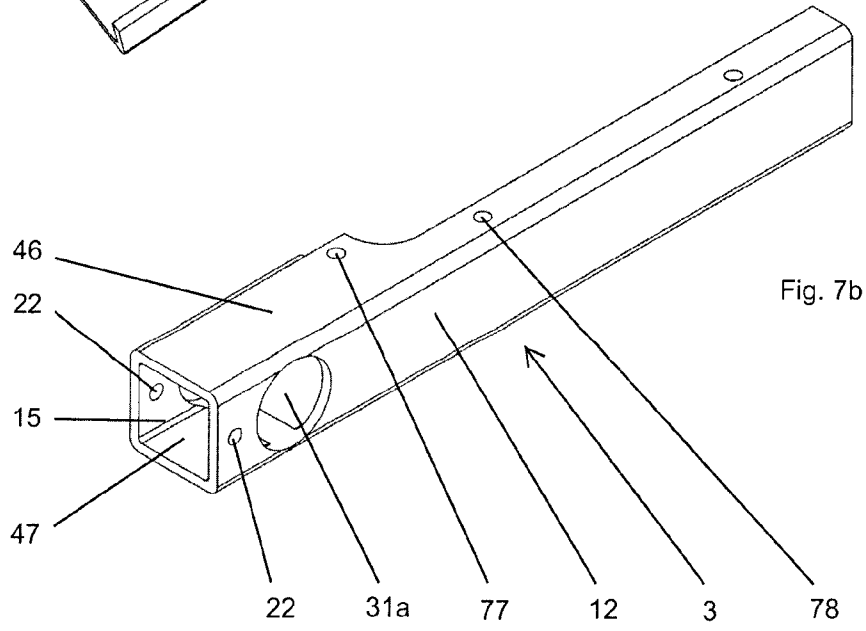
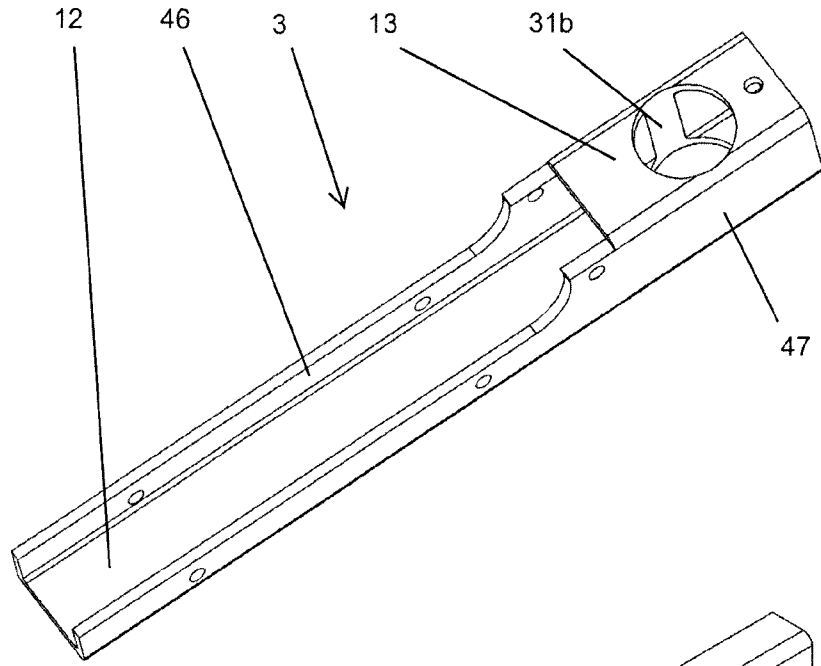

Fig. 7b

Fig. 8

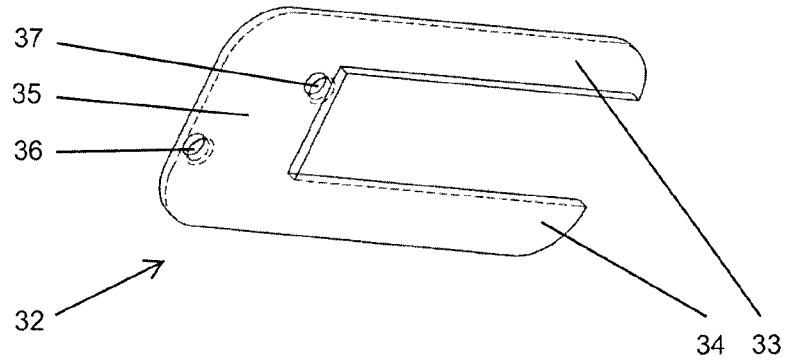

Fig. 9

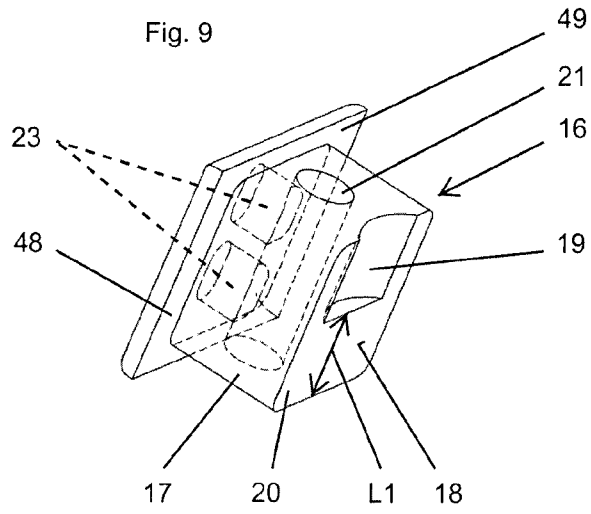
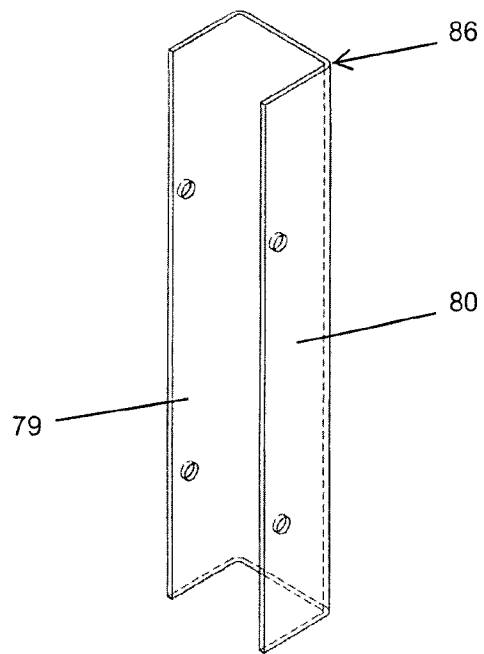

Fig. 10



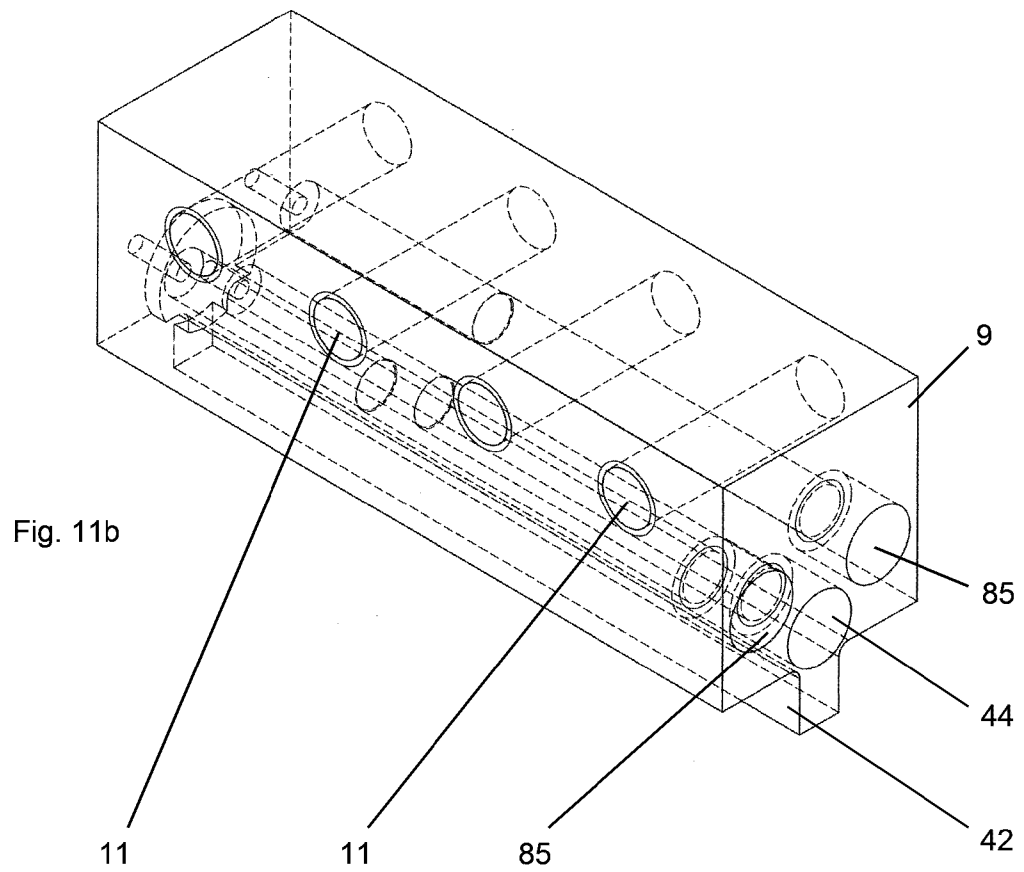
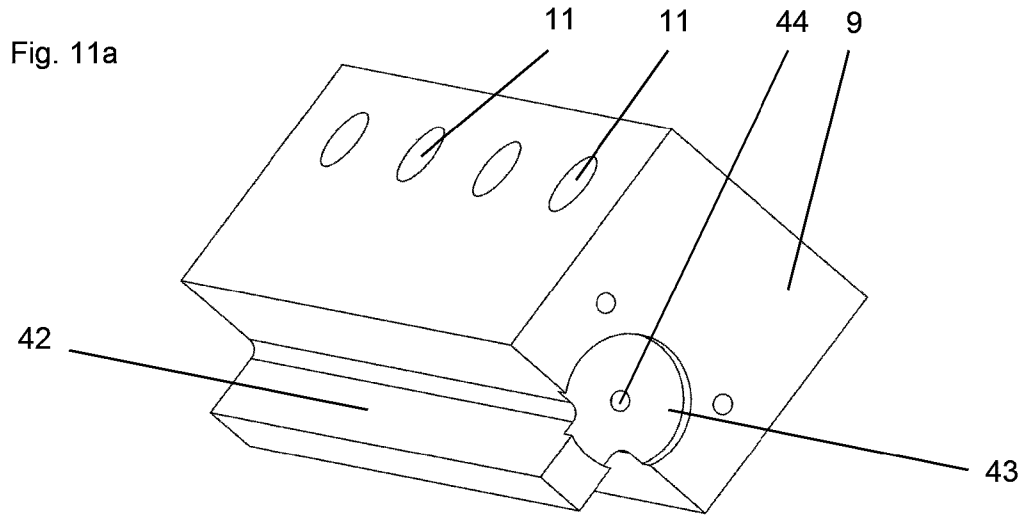

Fig. 12a

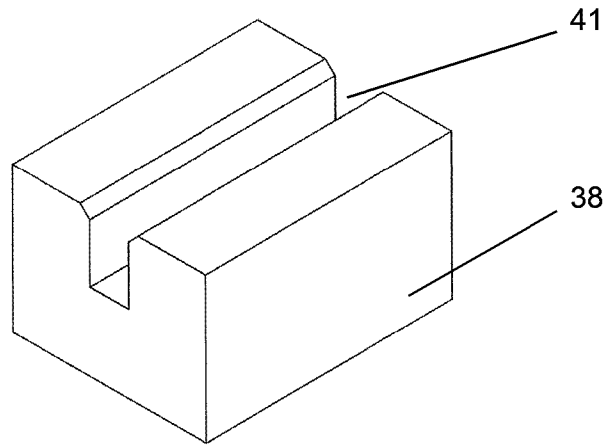

Fig. 13

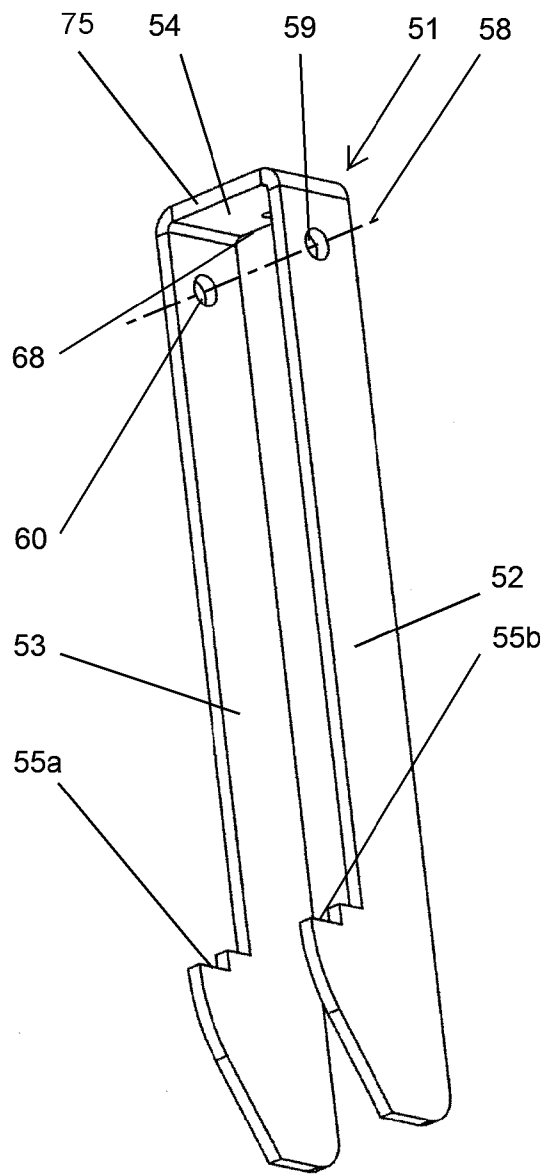

Fig. 12b

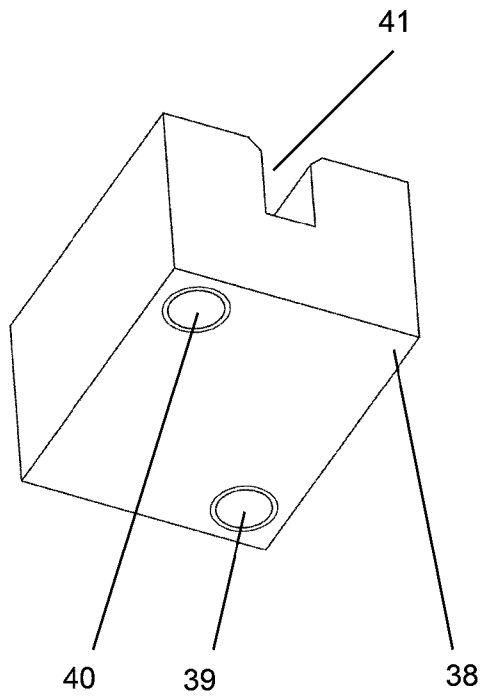

Fig. 14a

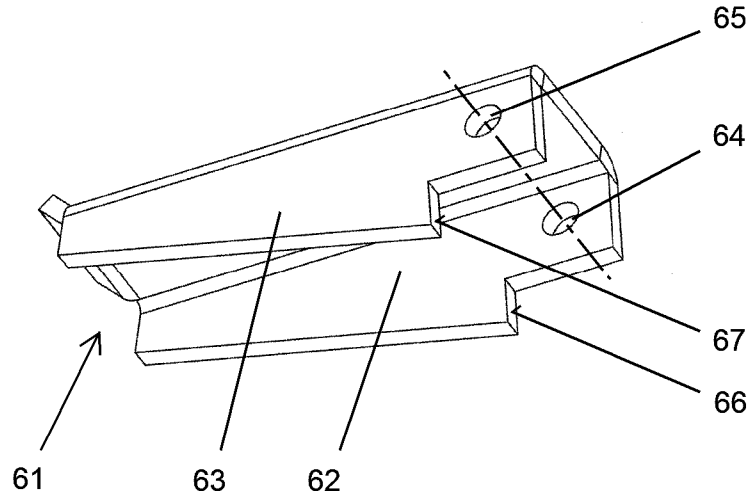
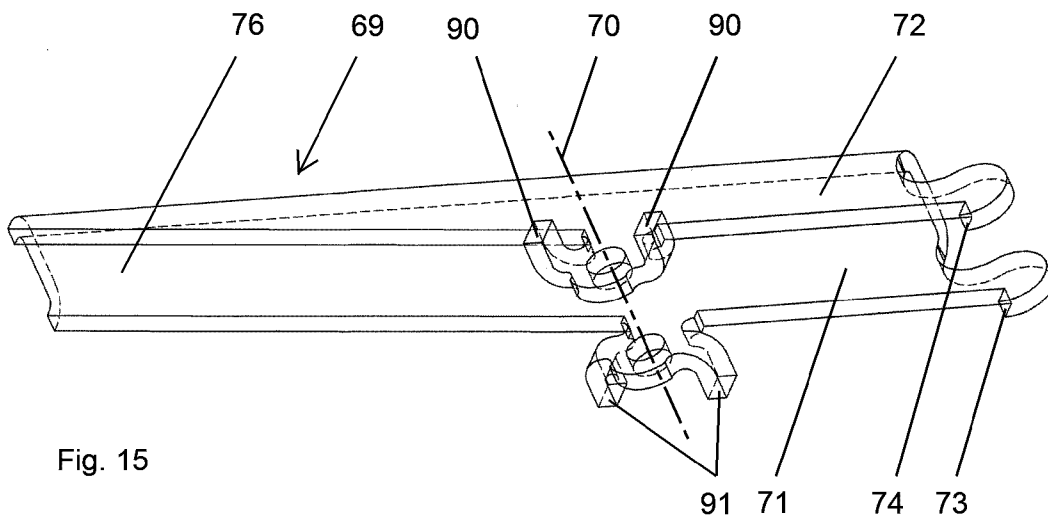
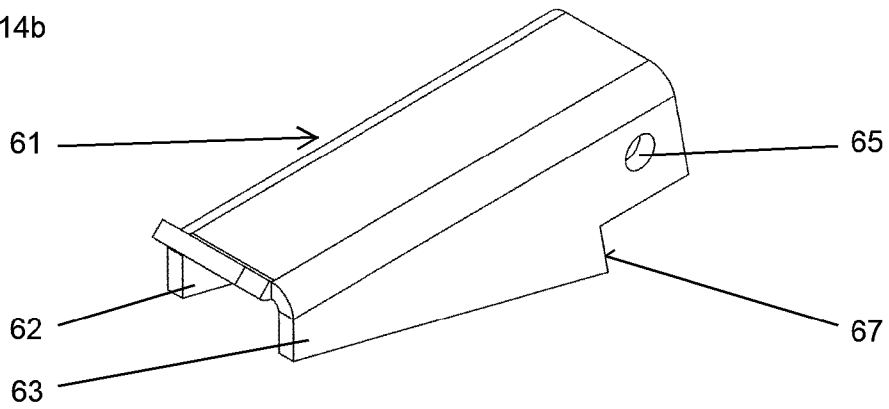

Fig. 14b



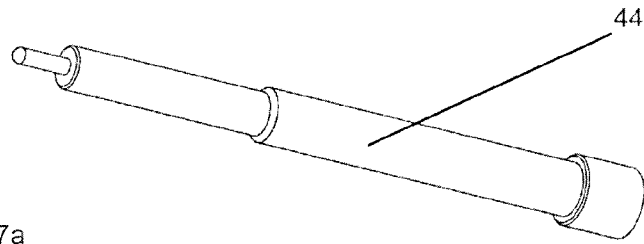

Fig. 17a

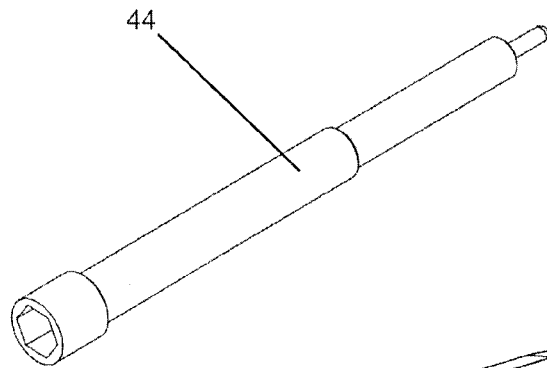

Fig. 17b

Fig. 16

