

(No Model.)

7 Sheets--Sheet 1.

S. D. TUCKER.

TRIPPING MOTION FOR PRINTING MACHINES.

No. 573,425.

Patented Dec. 15, 1896.

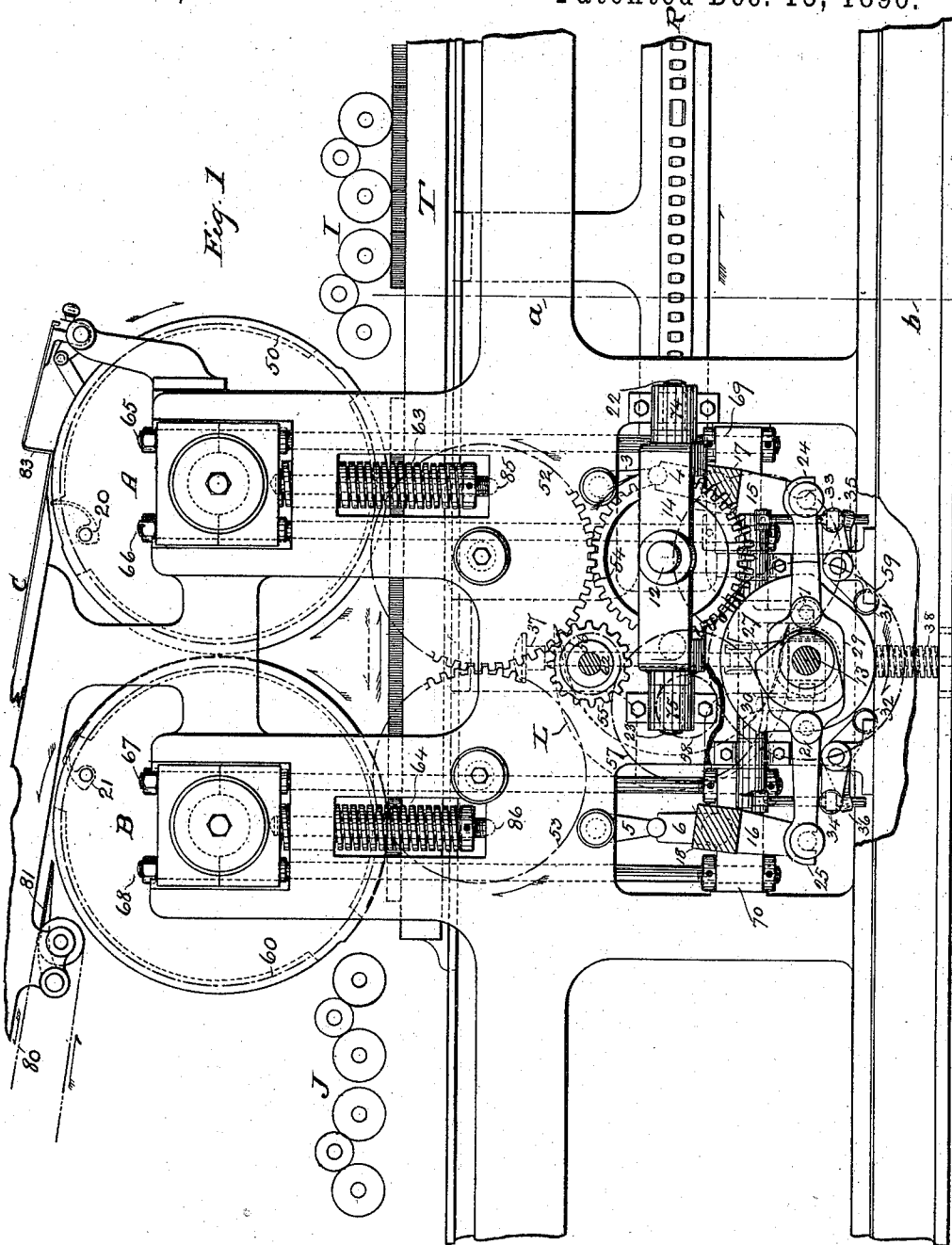

Attest  
J. F. Keloe  
Geo. H. Bette.

Inventor:  
Stephen D. Tucker  
by  
Philip Munson & Phelps,  
Attys

S. D. TUCKER.  
TRIPPING MOTION FOR PRINTING MACHINES.

No. 573,425.

Patented Dec. 15, 1896.

Fig. 2.

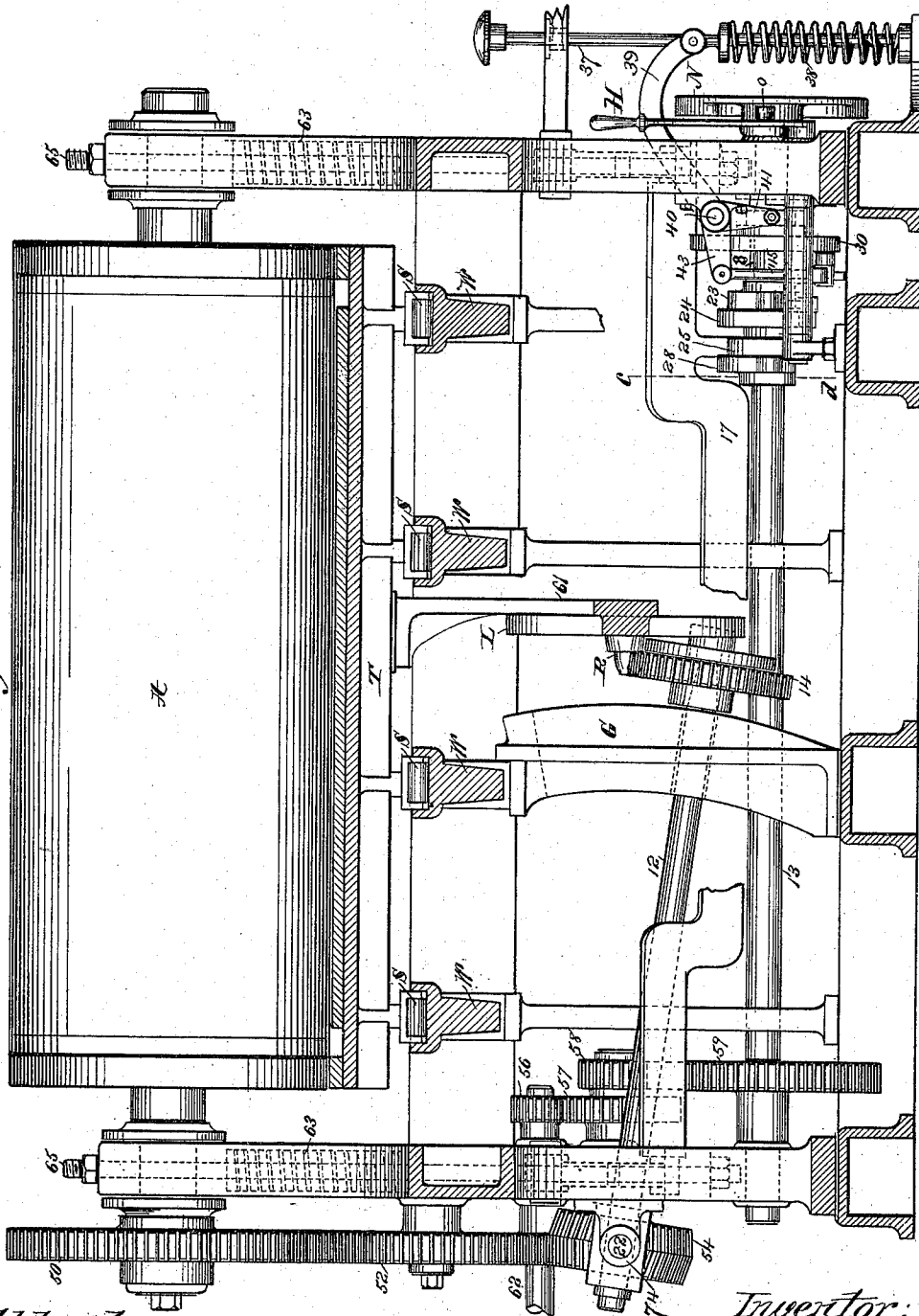

Attest:  
*J. F. Mohr*  
*Geo. H. Botts.*

Inventor:  
*Stephen D. Tucker,*  
 by  
*Philip Munson, Printer.*  
*Hills*

S. D. TUCKER.

TRIPPING MOTION FOR PRINTING MACHINES.

No. 573,425.

Patented Dec. 15, 1896.

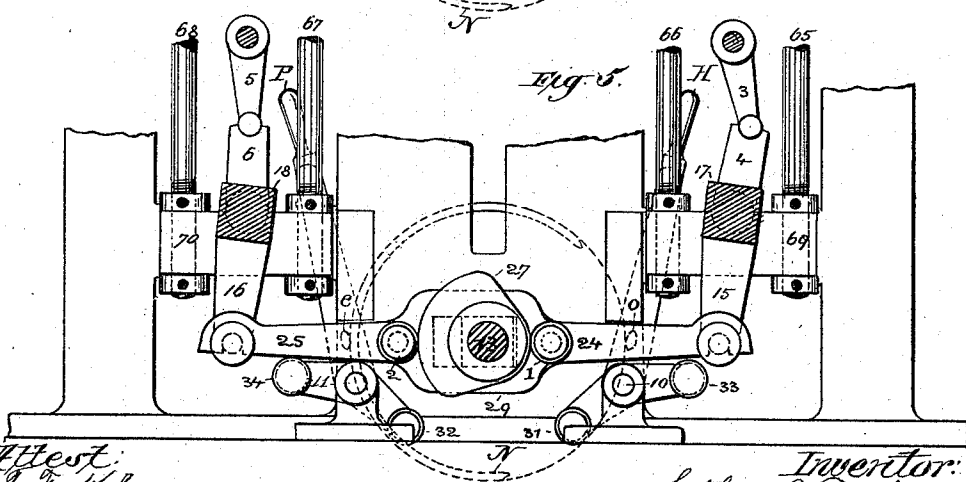
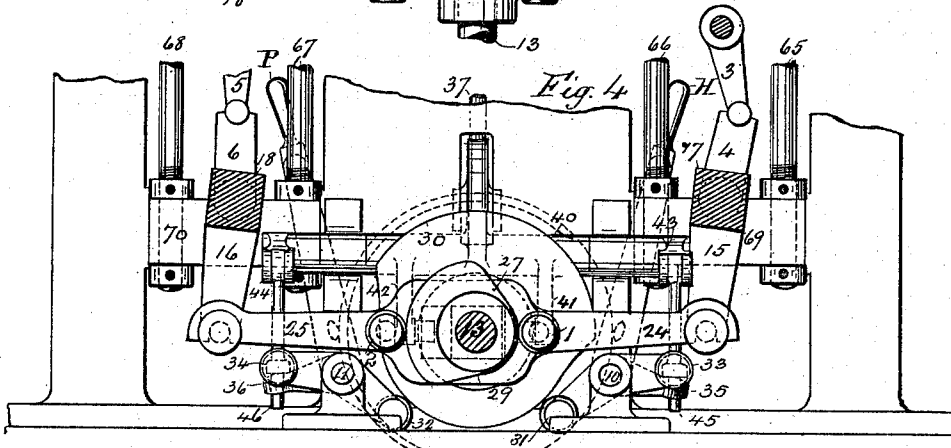
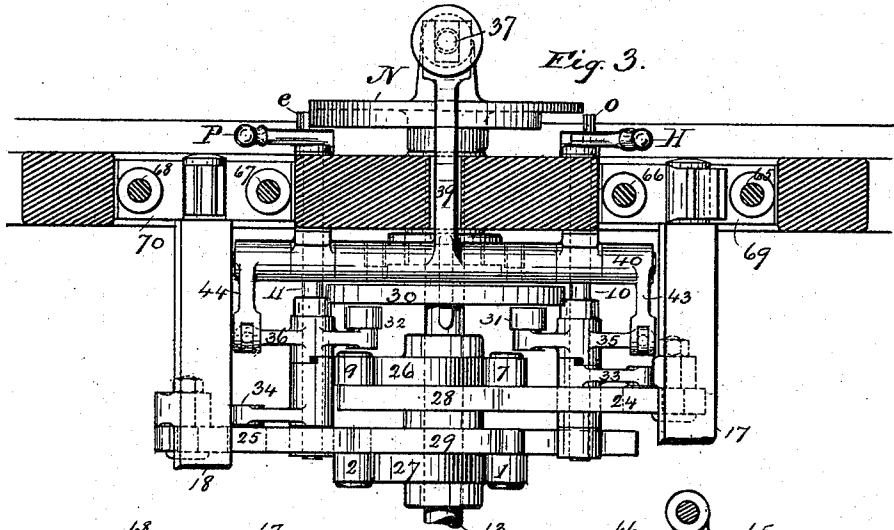

Attest:  
 J. F. Mahoe  
 Geo. H. Batts

Inventor:  
 Stephen D. Tucker  
 by  
 Philipp Rumann & Phelps  
 Attys

S. D. TUCKER.  
TRIPPING MOTION FOR PRINTING MACHINES.

No. 573,425.

Patented Dec. 15, 1896.

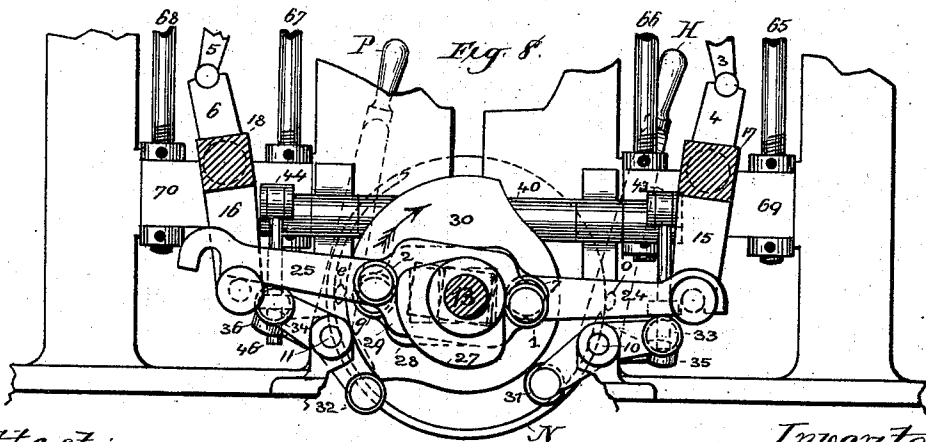
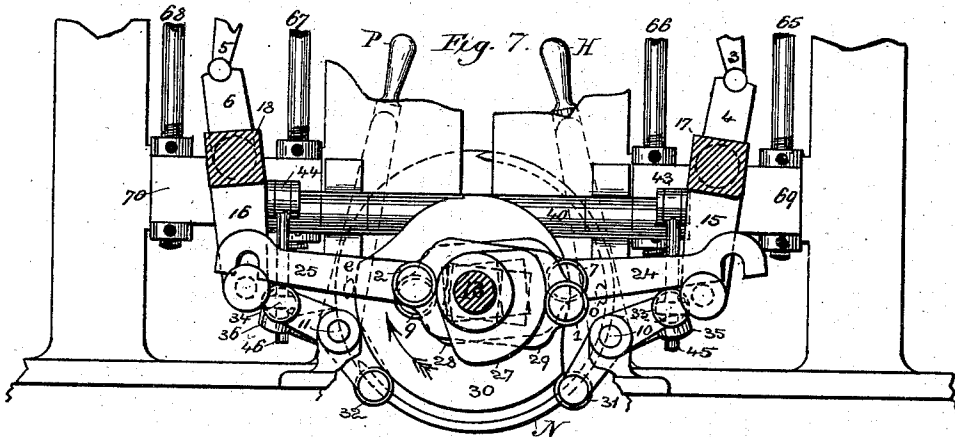
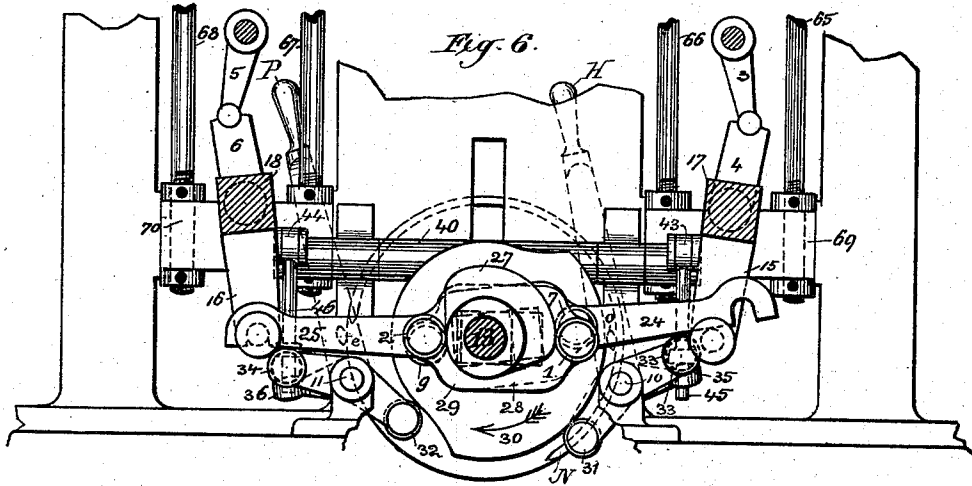

Attest:  
T. F. Kehoe  
Geo. H. Potts

Inventor:  
Stephen D. Tucker  
by  
Philip Munson Phelps  
Atty

S. D. TUCKER.  
TRIPPING MOTION FOR PRINTING MACHINES.

No. 573,425.

Patented Dec. 15, 1896.

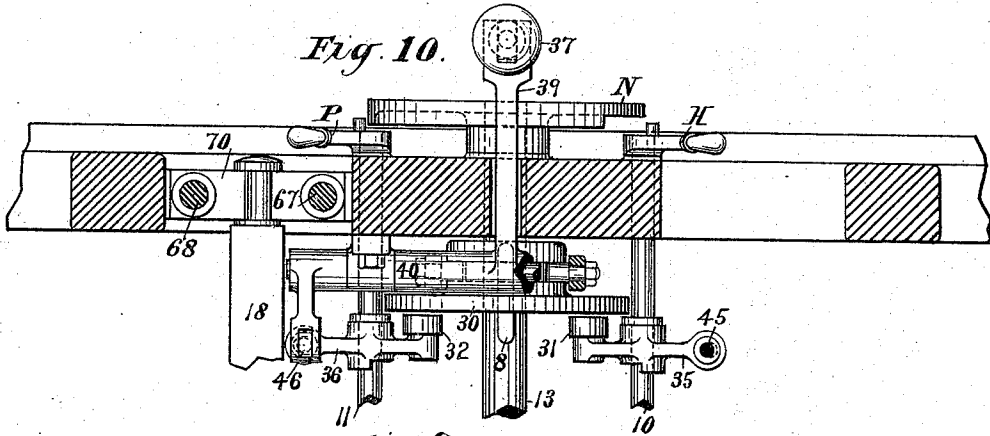

Fig. 10.

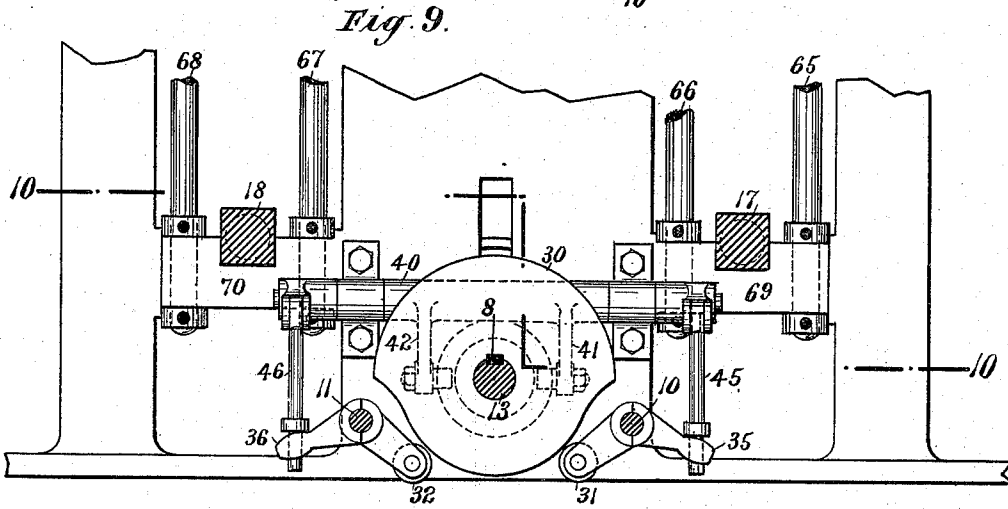

Fig. 9.

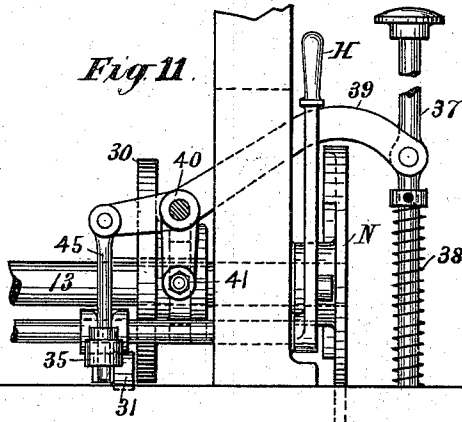

Fig. 11.

Attest:  
 Geo. H. Batts.  
 J. F. Kehoe.

Inventor  
 Stephen D. Tucker  
 by *Chas. Munson & Phelps*  
 Atty.

S. D. TUCKER.

TRIPPING MOTION FOR PRINTING MACHINES.

No. 573,425.

Patented Dec. 15, 1896.

Fig. 12.

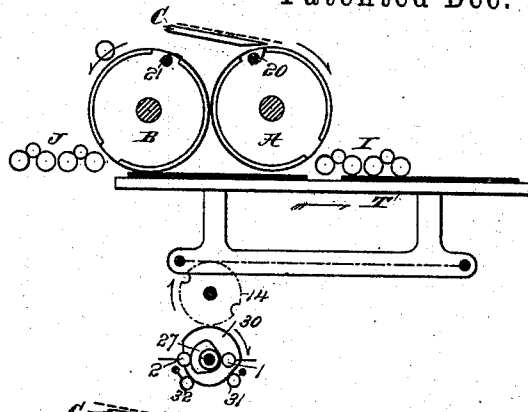

Fig. 13.

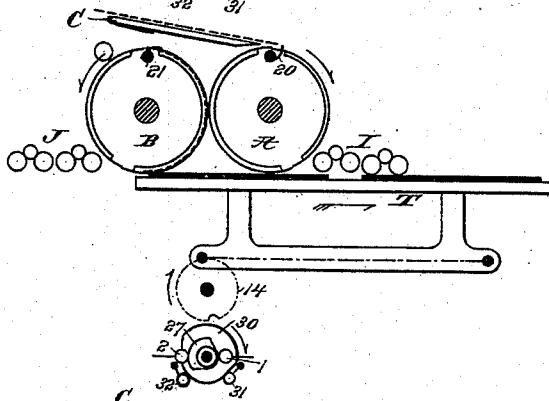

Fig. 14.

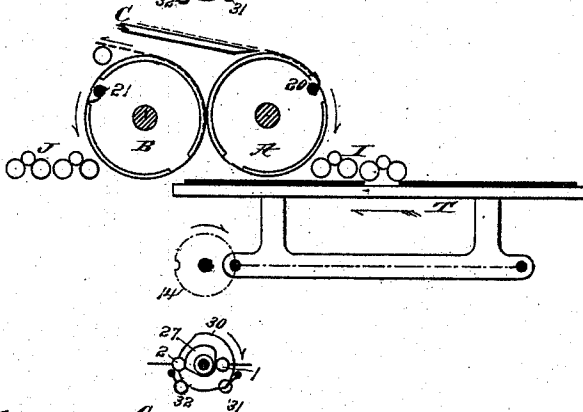
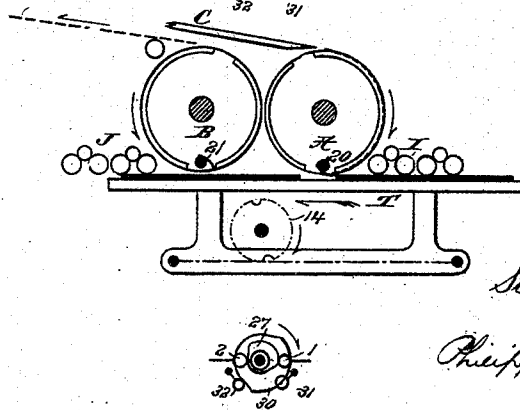

Fig. 15.



Attest:

T. F. Kehoe

Geo. H. Potts

Inventor:

Stephen D. Tucker

by

Chas. Sumner Phelps

Attys

S. D. TUCKER.  
TRIPPING MOTION FOR PRINTING MACHINES.

No. 573,425.

Patented Dec. 15, 1896.

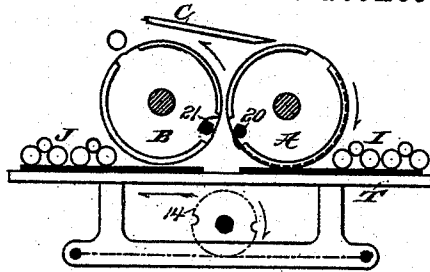

Fig. 16.

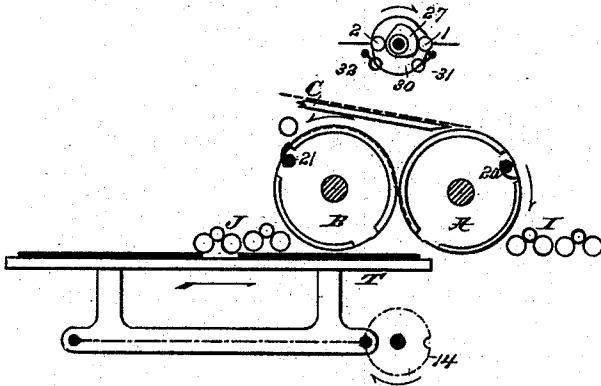

Fig. 17.

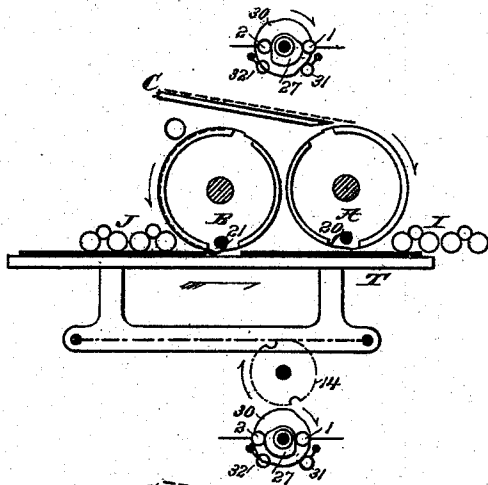

Fig. 18.

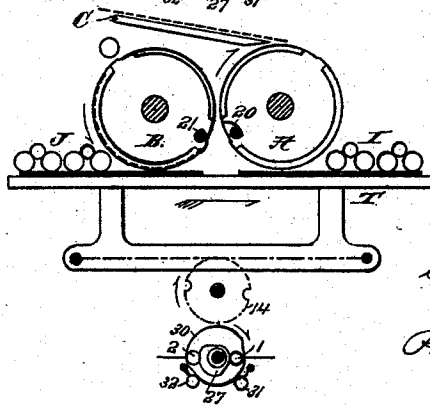

Fig. 19.

Attest:  
J. F. Schaefer  
Geo. H. Potts

Inventor:  
Stephen D. Tucker  
by  
Philip J. Johnson  
Attys

# UNITED STATES PATENT OFFICE.

STEPHEN D. TUCKER, OF NEW YORK, N. Y., ASSIGNOR TO ROBERT HOE,  
THEODORE H. MEAD, AND CHARLES W. CARPENTER, OF SAME PLACE.

## TRIPPING-MOTION FOR PRINTING-MACHINES.

SPECIFICATION forming part of Letters Patent No. 573,425, dated December 15, 1896.

Application filed November 17, 1892. Serial No. 452,299. (No model.)

*To all whom it may concern:*

Be it known that I, STEPHEN D. TUCKER, a citizen of the United States, residing at New York, county of New York, and State of New York, have invented certain new and useful Improvements in Tripping-Motions for Double-Cylinder Flat-Bed Printing-Machines, fully described and represented in the following specification and the accompanying drawings, forming a part of the same.

This invention relates to that class of printing-machines in which two rotating impression-cylinders cooperate with a flat reciprocating type-bed that carries two printing-forms, and more especially to such of these machines as are provided with a single feed-table and one delivery mechanism and have their impression-cylinders furnished with means for transferring the sheets from the primary to the secondary cylinder, so that such sheet may be perfected while passing continuously through the machine; but this invention may also be applied to such printing-machines when they are provided with means for feeding sheets to each of their impression-cylinders and with two deliveries and operate to print two sheets with one impression each. In these machines the cylinders must be alternately lowered into printing position, so that each may produce an impression during every second revolution, and during its alternating revolution each cylinder must be raised out of printing relation to the bed, so as to avoid contact with the printing-form then passing beneath it, which is a time when the cylinder does not carry a sheet to be printed. This alternate raising and lowering action of the cylinders is automatically performed, and a machine equipped with means for accomplishing it will properly perform so long as sheets are regularly fed to it; but in consequence of the possibility of failing to feed the sheets regularly or other defective action it is requisite that this raising and lowering mechanism shall be within the control of the feeder and a tripping of the said mechanism be possible at such times as will prevent any improper action of the machine.

The present invention provides a tripping mechanism of such improved construction

that it may not only operate to control the vertical movements of the cylinders independently of their automatic action, but be capable of operating only at such times as the cylinders may properly be so acted upon and then first upon the primary impression-cylinder and thereafter upon the secondary impression-cylinder; and the invention consists in the specific constructions and combinations of parts for carrying it into practical effect and means for insuring the perfect bringing of the parts when once tripped into action and for locking them against untimely operation, as is hereinafter explained at length and specified in the claims.

A practical embodiment of the invention is shown in the accompanying drawings, in which—

Figure 1 is a side elevation, as seen from the gear side of the machine, of so much of a double-cylinder flat-bed printing-machine as is requisite to illustrate the present invention. In this view such of the lower parts as would obscure others more important to be illustrated are broken away upon the section-line *c d* of Fig. 2, and some of the gearing is shown in dotted lines only. Fig. 2 is a transverse sectional elevation of the same machine on the line *a b* of Fig. 1, as seen in looking toward the impression-cylinders. Fig. 3 is an enlarged sectional plan view. Figs. 4, 5, 6, 7, 8, and 9 are enlarged side elevations of the cylinder raising and lowering mechanisms and of the tripping mechanism, as seen from the gear side of the machine. Fig. 10 is a plan view of the parts shown in Fig. 9, taken on the sectional line of said Fig. 9; and Fig. 11 is a side elevation of the same parts. Figs. 12 to 19 are diagrams illustrating the parts shown in various positions which they have during a complete reciprocation of the type-bed.

The printing-machine illustrated is, in its general characteristics, of the common type of machine. It consists of two rotating impression-cylinders A B and a flat reciprocating type-bed T, which cooperates therewith in producing the impressions necessary to perfect a sheet.

The primary impression-cylinder A and the secondary impression-cylinder B are each

mounted in the framework so as to be capable of vertical movement, which is attained by mounting their shafts in journal-boxes constructed to slide between guides, which are provided in the side frames. These cylinders A and B are respectively provided with sheet-carrying grippers or fingers 20 21, of ordinary construction, which are rocked to close and seize the sheet in order to hold and carry it upon the surface of the cylinder and rocked to open and release the sheet when it is to be delivered by the primary to the secondary cylinder or by the secondary cylinder to the delivery devices, which carry it out of the machine.

The cylinders A B are so positioned as to be nearly in contact, and they are rotated in unison by means of wheels 50 60, which do not gear together, but respectively mesh with intermediates 52 53, which are geared together and the former of which gears with and imparts motion to the double-faced pinion 54 on the outer end of the oscillating shaft 12, at the opposite or inner end of which shaft is carried the bed-driving pinion 14.

The type-bed T horizontally reciprocates upon rollers carried by sliders S in ways W, as is usual, and it is provided centrally with a hanger, as 61, which supports a double-faced rack R, with which said pinion 14 engages. At each end of this rack R it is provided with curved shoes L, forming guide-ways which when engaged by the elongated inner end of the shaft 12 directs said shaft upward at one end and downward at the other end of each stroke of the bed, and thus carries the pinion 14 from the lower to the upper and from the upper to the lower side of the double-faced rack R, so that it will drive the rack, and hence the bed, first in one direction and then in the other, the size of the pinion 14 in this instance being such that it makes four revolutions to one complete reciprocation of the type-bed. This shaft 12 is hung at its outer end in a journal-box that is provided with oppositely-projecting studs 22 23, which turn in bearings 74 75, secured to the side frame. It is thus capable of vertical oscillation in the guide G, in which movement the double-faced pinion 54 it carries first engages its one face and then its other face with the wheel 52. The main driving-shaft 62, which will be provided with the usual driving-pulleys, is mounted in one side frame and carries outside the frame a driving-pinion 55, (of sixteen teeth,) which meshes with the toothed wheel 52, (an intermediate,) that gears with the cylinder-wheel 50, (of sixty-four teeth,) said wheel 52 in turn gearing with the wheel 53 (an intermediate) and the latter with the cylinder-wheel 60, (of sixty-four teeth.) On its inner end said driving-shaft carries a driving-pinion 56, (of twenty teeth,) which gears with a wheel 57, (of fifty teeth,) that is mounted on a stud and carries a pinion 58, (of twenty teeth,) which engages a wheel 59,

(of sixty-four teeth,) that is fast upon and drives the cam-shaft 13. The main shaft 62 thus drives both the cylinders and the bed, and the relation of the gearing is such that the bed-driving shaft 12 makes four revolutions to one of the cam-shaft 13. Of course any other gearing might be adopted for moving these various parts concertedly.

The type-bed T is provided with the two forms necessary to print the opposite sides of a sheet, which forms are inked by suitable inking devices I J, provided at the outer sides of the impression-cylinders and arranged in position to suitably ink the forms on the bed as they pass beneath them. A feed-board C is provided, from which the sheets may be successively fed to the grippers 20 of the primary cylinder A, and a delivery mechanism, as the guiding-conductors 81 and endless carrying-tapes 80, for receiving the perfected sheets from the grippers 21 of the secondary cylinder and delivering them in succession from the machine.

It will now be understood that a sheet fed from the table C against the drop-guides 83 to be taken by the grippers 20 of the primary impression-cylinder A, as in Figs. 12, 13, and 14, will, when carried by said cylinder into contact with the appropriate form on the type-bed T, be printed upon one side, as in Figs. 15 and 16, while the bed is traveling in the direction indicated by the dotted arrow in Fig. 1, and then be delivered to the grippers 21 of the secondary impression-cylinder B, as in Fig. 17, and be printed upon the opposite side by that cylinder from the appropriate form on the type-bed, as in Figs. 18, 19, and 12, while the latter is traveling in the direction indicated by the full-lined arrow, as in Fig. 1, and that when the grippers 21, carrying this perfected sheet, arrive at a convenient point beneath the feed-board C said grippers will be opened to release this sheet to the delivery mechanism, as in Figs. 13, 14, and 15.

In Fig. 12 the mechanisms are in the positions which they have when the grippers of the primary cylinder are closely approaching the sheet-seizing point and just previous to the time when they close to take a sheet from the feed-board C, which is also the time when the secondary cylinder is about to discharge a perfected sheet to the delivery mechanism, Fig. 13 showing an intermediate position and Fig. 14 the position of the parts at the moment when the grippers are closed upon the sheet.

The two forms on the type-bed are imposed in opposite directions, and during the making of the first impression or printing upon one side of the sheet the cylinders A and B each makes one revolution and the type-bed makes a movement in the direction of the dotted arrow, Fig. 1, the sheet being carried by the primary cylinder A and pressed into contact with the right-hand form carried by the type-bed, as in Figs. 15 and 16, during which printing operation the cylinder B, being raised, re-

volves out of printing position, and when during this revolution of the two cylinders their grippers 20 and 21 meet and pass a common point the grippers 20 open to release the once-printed sheet and the grippers 21 close to seize this sheet and carry it around upon the secondary cylinder B, as in Fig. 17. During the next revolution of the said cylinders A and B, at which time the type-bed makes its movement in the direction of the full-lined arrow, the cylinder B, then lowered into printing position, presses the unprinted face of the once-printed sheet into contact with the left-hand form carried by the type-bed, as in Figs. 18, 19, and 12, and the cylinder A, then raised, revolves out of printing position, the two cylinders thus being actively engaged in printing only during alternate revolutions of them. Now in order that when the primary impression-cylinder A is cooperating with the type-bed T to impart the first impression to the sheet the form carried by the bed then passing beneath the secondary cylinder B may not have contact with that cylinder, and that when the second impression-cylinder B is cooperating with the type-bed T to impart the second impression to said sheet the form carried by the bed then passing beneath the primary cylinder A may not have contact with that cylinder, both of said cylinders are provided, as is customary, with automatic means for alternately raising and lowering them at appropriate times. This raising and lowering of these cylinders is accomplished as follows: Each cylinder has its sliding journal-boxes seated upon springs, as 63 64, which springs are housed in recesses in the side frames and retained in position by means of spindles, as 85 86, which are screw-threaded and provided with nuts to adjust the resilient power of said springs. The journal-boxes at the opposite ends of the cylinder A are each provided with a pair of vertical rods 65 66, and the journal-boxes at the opposite ends of the cylinder B are each provided with a pair of vertical rods 67 68, which rods extend through said journal-boxes, are guided in suitable slots in the side frames, and have their lower ends secured to vertically-sliding heads 69 70, that move in suitable guideways provided in the side frames, and all of these rods have screw-threaded lower ends furnished with nuts, whereby the pressure of the cylinders upon the forms may be accurately adjusted.

The cylinders are drawn downward into printing position by the action of toggles, as 3 4 and 5 6, when said toggles are straightened and are raised by the action of the springs 63 64 when said toggles are rocked out of alinement. The members 3 5 of the toggles are pivoted to the side frames, and the members 4 6 of the toggles project from rock-shafts 17 18, whose bearings rock in the sliding heads 69 70, that are duplicated in the opposite side frames of the machine, and from which rock-shafts at one side of the ma-

chine depend rock-arms 15 16, through which said rock-shafts are actuated by means of connecting-rods 24 25, which have hooked ends, so that they may be engaged with and disengaged from studs at the ends of said rock-arms 15 16. Each of these connecting-rods 24 25 is a prolongation of a yoke, as 28 29, both of which yokes embrace and are guided by the cam-shaft 13, and these yokes are each provided with pairs of friction-rollers, as 7 9 and 1 2, which are respectively engaged by the impression-cams 26 27, which cams, being fast on said shaft 13 and of like shape and alinement, cause the connecting-rods 24 25 to concertedly reciprocate.

Normally the connecting-rods 24 25 have their hooked ends engaged with the studs on the rock-arms 15 16, as in Fig. 4, and it therefore results that as the cam-shaft 13 revolves the toggles 3 4 and 5 6 are alternately rocked out of alinement to permit a cylinder to rise out of printing position (see cylinder A in Fig. 1) and into alinement to draw a cylinder downward into printing position. (See cylinder B in Figs. 1 and 12.) The cam-shaft 13 makes one revolution to two revolutions of the cylinders A B and to each complete reciprocation of the type-bed, and the impression-cams 26 27 are so positioned on the cam-shaft 13 that the cam 26 begins to straighten the toggles 3 4 to depress the impression-cylinder A where the grippers 20 of that cylinder are seizing the sheet, as in Fig. 14, so as to carry it onward to be printed, while the cam 27 begins to operate to straighten the toggles 5 6 to depress the impression-cylinder B as the grippers 21 of that cylinder are moving away from the sheet-delivery point and are carrying the sheet onward for a second printing, as in Fig. 17, the lowering of each cylinder thus begun being completed to bring it into printing relation thereto just before it is engaged with its cooperative form on the bed. The movements are also so timed that when the primary cylinder A is pressing a sheet into contact with one form upon the type-bed and printing the first impression thereon the toggles 3 4 will be straightened, so as to depress the said cylinder into printing position, and at the same time the toggles 5 6 will be thrown out of alinement, so as to permit the cylinder B to be raised out of printing position, (see Fig. 15), and when this sheet is carried upon the secondary impression-cylinder B and is being pressed by it into contact with the other form upon the type-bed, and thus printed with its second impression, the said toggles 5 6 will be straightened, so as to depress the cylinder B into printing position with respect to this form and the toggles 3 4 will be thrown out of alinement, so as to permit the primary cylinder to be raised out of printing position with respect to the other form and thus prevent its contact therewith. (See Fig. 18.) The latter positions of the toggles are shown in Fig. 1, where the parts are in the positions

they have at the time when the primary impression-cylinder is about to receive a sheet and the secondary impression-cylinder is just finishing its impression and the type-bed is traveling in the direction of the full-line arrow. So long as sheets are regularly fed from the table C to the grippers 20 of the primary cylinder A these printing operations may proceed without interruption and a sheet will be perfected at each second revolution of the said cylinders A and B; but it sometimes happens in these rapidly-operating mechanisms that a feeder will fail to feed a sheet to or properly adjust one, so that it will be taken into the machine by the grippers 20 of the primary impression-cylinder A, and since, in case of the absence of a sheet on said cylinder, it will result that the form on the type-bed will, if the primary impression-cylinder is brought into printing position, imprint an impression upon the naked blanket carried by said cylinder, mechanism must be provided whereby said cylinder shall be maintained out of printing relation to its form during any revolution of it when it carries no sheet, and since, if the primary cylinder A has made its active or printing revolution without being supplied with a sheet, there will be a like absence of a sheet upon the secondary impression-cylinder B during its succeeding printing revolution, when it ordinarily would be lowered into printing position, said cylinder B must also be maintained out of printing relation to the bed during its said succeeding revolution. This maintaining of the two impression-cylinders out of printing position at such times as they are unprovided with a sheet to be printed upon is accomplished by a tripping mechanism whereby the toggle-connecting rods 24 25 are tripped, so that during the appropriate revolution of each of these cylinders their toggles may not be straightened to draw the cylinder down into printing position.

In practical operation if the grippers of the cylinder A fail to take a sheet during the printing rotation of that cylinder the toggles of that cylinder, as has been shown, must be tripped, so that it will remain out of printing position, and since the secondary cylinder, which at this time, when irregular action has required the tripping movement to be made, will be operating to complete the printing upon or perfecting a previous sheet already received by it from the primary cylinder, (see Figs. 19, 12, and 13,) it becomes necessary that the trip-motion shall be so arranged to operate that the primary cylinder A will be the first to trip, and that its tripping shall always be followed by the tripping of the secondary cylinder after it has printed the sheet then upon it and been raised out of printing position, thus insuring the perfecting of the sheet then being acted upon by the secondary cylinder and leaving both cylinders raised for appropriate non-action in the absence of a sheet. It is also necessary, in order to secure a per-

fect operation of the cylinders as well as a perfect cooperation between them, that it shall only be possible to trip the primary cylinder at an appropriate time, which is when the cylinder is raised out of printing position and at a time when it should receive a sheet, and that the primary impression-cylinder A shall always come into printing position first, so that the secondary cylinder when it operates shall always be furnished with a sheet. To accomplish these results, the constantly-revolving cam-shaft 13, which carries the impression-cams 26 27, through which the toggles are automatically operated to raise and lower first one impression-cylinder and then the other, and which makes one revolution for each sheet fed or during a complete reciprocation of the type-bed, is provided with a tripping-cam 30, that is capable of moving sidewise upon said shaft, guided by a feather 8, which movement is accomplished by means of a tripping-rod 37. This tripping-rod 37 is seated upon a spring 38 and moves a treadle or rock lever 39, fast upon an oscillating shaft 40, that carries rock-arms 41 42, which enter a grooved collar attached to the cam 30, this cam being thus moved inward by the rock-arms 41 42 and outward by the spring 38. When moved inward, this cam 30 as it revolves bears upon the inner ends of and depresses rock-arms 31 32, which project from hubs that rock freely upon shafts 10 11 and have offsets that abut against similar offsets on hubs fast on said shafts, from which extend rock-arms 33 34, the said arms 33 34 being made separate pieces, so as to provide for the hand tripping hereinafter explained. The movement of the rock-arms 31 32 is thus transmitted to the rock-arms 33 34, which thus act to lift the hooked ends of the connecting-rods 24 25 free from the studs on the ends of the toggle rock-arms 15 16, and these operations are so timed that this cam 30 will disconnect said rods 24 25 just before the impression-cams 26 27 respectively begin the operation of throwing the toggles into alignment, whereby one or the other cylinder would be lowered into printing position. When this tripping-cam 30 is free to do so, it is moved outward by the spring 38 and becomes inactive, and it then revolves with the cam-shaft, but at one side of and therefore inoperatively with relation to the arms 31 32.

To perform the tripping operation, the tripping-rod 37 is depressed, thus through the treadle-lever 39, the rock-shaft 40, and its rock-arms 41 42 throwing the tripping-cam 30 laterally into the vertical plane of or in alignment with the studs or bowls on the inner ends of the arms 31 32, as in Fig. 4, and as this cam constantly revolves in the direction indicated by the arrow its high part will bear upon the inner end of the rock-arm 31, raise the rock-arm 33, lift the connecting-rod 24, and disengage its hooked end from the rock-arm 15, as in Fig. 6. This causes the rod 24, when moved by the cam 26, to pass ineffect-

ively over the rock-arm 15, thus leaving the primary cylinder in its raised or non-printing position, during which movement of the rod 24 its companion rod 25 will have drawn the rock-arm 16 inwardly, thus throwing the toggles 5 6 out of alinement and allowing the secondary impression-cylinder to be raised, which movement is shown in Fig. 6. When, however, the high part of the tripping-cam 30 during this same rotation of it reaches and bears upon the inner end of the rock-arm 32, which is before the connecting-rod 25 begins its return movement, said rock-arm 32 will be actuated to raise the rock-arm 34 to lift the hooked end of the rod 25 out of engagement with the rock-arm 16, and thus disconnect these parts, as in Fig. 7, so that during its return or outward movement this rod 25 will pass ineffectively over the arm 16. Thus when tripped the primary impression-cylinder A will remain raised out of printing position and the secondary impression-cylinder B will also remain raised, and the two cylinders will be maintained in such raised positions so long as the tripping-rod 37 and treadle-lever 39 are depressed.

In order that the tripping-cam 30 may be moved laterally inward to carry its enlarged part into operative relation to the rock-arms 31 32, said arms are so positioned that normally their inner ends are a little farther away from the cam-shaft 13 than is the low part of the cam, and as said cam, when inoperative, turns in a different vertical plane and when operative turns in the same vertical plane in which said arms vibrate and slides laterally outward from one position to the other it follows that it can only be moved over the ends of and into operative relation to said rock-arms when, during its rotation, its low part is laterally opposite said arms, as in Figs. 1, 4, 19, 12, and 13, and the relative extent of the enlarged and low parts of said cam is such and the enlarged part of the cam is so related to the said rock-arms in their normal positions that the cam can only be moved past said rock-arms for engagement therewith after the rear end of its enlarged part has cleared the position of the rock-arm 32 (as is about to be accomplished in Fig. 8) and before the leading end of its enlarged part arrives at the position of the rock-arm 31, (as is about to be accomplished in Fig. 4,) and thus it must always first engage the rock-arm 31 that moves the tripping devices of the primary cylinder, and then in proper time engage the rock-arm 32 that moves the tripping devices of the secondary cylinder. This tripping-cam makes one revolution to two revolutions of the impression-cylinders, and as the arms 31 32 are normally so related to it that while about a quarter-revolution of the cam will take place between the contact of its enlarged part with the rock-arm 31 and its subsequent engagement with the rock-arm 32, and consequently between the tripping of the primary and secondary cylinders, said trip-

ping-cam 30 can only be moved into action during about a sixth of a revolution of it, for the reason that when the rear end of its enlarged part has cleared the plane occupied by the arm 31 that a farther sixth-revolution of it will bring said leading end at the plane occupied by the rock-arm 31. The movement of the cam 30 to produce the tripping action can therefore can only be made after its enlarged part has passed the end of the rock-arm 32, which acts upon the tripping devices of the secondary cylinder and before the leading end of its enlarged part has reached the inner end of the rock-arm 31, which acts upon the tripping devices of the primary cylinder, and then only while said cam is making about a sixth of a revolution, during which the impression-cylinders will make about a one-third revolution. When, however, the leading portion of the enlarged part of this cam passes the inner end of the rock-arm 31 without that cam having been moved sidewise into engagement with said rock-arm, it will of course be too late to slide the cam, since it will then abut laterally against said rock-arm, and thus be prevented from moving past it, and hence there can be no tripping action through either rock-arm until the enlarged part of the cam has passed the inner ends of both of the rock-arms 31 32 and again presents its low part to them, as in Figs. 4 and 19.

When, as in case of failure to provide it with a sheet, it becomes necessary to trip the cylinder A so as to maintain it out of printing position, its companion cylinder B will also be held in a raised position at the proper sequential time. This tripping action may be accomplished, as has been shown, during about a third of a revolution of the impression-cylinders or while the low part of the tripping-cam 30 is presented to the rock-arms 31 32, but its position relative to the impression-cams 26 27 is such that the cam 26 will act upon the rod 24 very shortly after the leading end of the cam 30 reaches a point where, if it has been moved into the same vertical plane, it will previously act upon the rock-arm 31 and uncouple the rod 24. The concerted movement of these cams 30, 26, and 27 is so timed with relation to the rotation of the cylinders that the low part of the cam 30 is only in position to enable it to be moved sidewise over the rock-arms 31 32 during that third revolution of the cylinder A when the grippers 20 are approaching and passing beyond the sheet-feeding point, where said grippers close to take a sheet from the feed-board C, which movement is substantially shown by Figs. 19, 12, 13, and 14, and the mechanisms are also so timed that the extent of travel of said grippers beyond the feeding-point, during which the tripping may be effected, shall not be too great, for the reason that the tripping must be effected before the impression-cam 26 begins to move the rod 24 to straighten

the toggles 3 4 to depress the cylinder A into printing position, which depression of it when no tripping is required should be begun immediately after the grippers 20 have taken a sheet at said feeding-point, because such depression is slowly made while the cylinder turns considerably and must be completed just before the head of the sheet meets the form which is to print upon it, as in Fig. 15.

From the foregoing it will be seen that the primary cylinder will always be tripped first and that when it has been tripped the secondary cylinder must also be tripped during its next alternating revolution. This is requisite because the tripping of the primary cylinder occurs when that cylinder has not taken a sheet during their coinciding revolutions when the secondary cylinder is carrying and perfecting a sheet, as in Figs. 18, 19, 12, and 13, while during its succeeding revolution this secondary cylinder will be without a sheet, not having received one from the primary cylinder. It will also appear that after these cylinders have been successively tripped the primary cylinder will always be the first to return to printing position through the withdrawal of the cam 30, followed by the secondary cylinder, and this is requisite because it is the primary cylinder to which is fed the sheet to be printed; first on one side by the primary and then on the other side by the secondary cylinder, and if the secondary cylinder was the first to be brought into printing position it could not then have received a sheet from the primary cylinder, and hence it is that the cam 30 must be locked against withdrawal until the primary cylinder once tripped is again carried into position to take a sheet.

It is essential that the tripping mechanism, when once set into operation, shall effectively operate to retain the primary cylinder raised out of printing position and continue to so operate until the entire motion is completed with respect to both cylinders.

The tripping rock-arm 31 actuates an auxiliary rock-arm 35, and the tripping rock-arm 32 actuates a similar auxiliary rock-arm 36, and these rock-arms 35 36 respectively engage collars provided on rods 45 46, that respectively depend from rock-arms 43 44, projecting from the opposite ends of the rock-shaft 40. Thus, when the treadle-lever 39 is moved and the cam 30 is entered into even slight engagement with the rock-arm 31 and said arm is rocked to lift the rod 24, the auxiliary rock-arm 35 at once engages and lifts the rod 45, and thus forces through the intermediate devices the tripping-cam 30 all the way inward, and thus supplements to completion any partial movement of the cam caused by a faulty foot movement of the operator, and when the high part of the cam 30 engages the rock-arm 32 the auxiliary rock-arm 36 is lifted to press against the collar on the rod 46 with like effect. These arms 35

36 thus successively continue to bear upwardly upon the rods 45 46 and press inwardly the arms 41 42 until the high part of the cam has passed the rock-arm 32, thereby preventing the withdrawal of the tripping-cam 30 from engagement with its operating rock-arm 31 or 32 so long as one of the rods 24 or 25 is held by its rock-arm 31 or 32 disconnected from the rock-arm 15 or 16 of the toggles. By these arrangements a timely as well as a complete tripping of both cylinders in their appropriate order is secured, and the tripping-cam once set into operation is moved into and locked in position during its entire period of active operation.

In making the tripping action the foot-lever 37 is quickly depressed to set the parts into action, which action, as has been explained, will, when once begun, be carried out in proper time with respect to both cylinders. If after such tripping action a sheet is properly fed to and taken by the grippers of the primary cylinder A when next in position to receive a sheet and the foot-lever 37 having in the meantime been released, the cam 30 will, after it has been compelled to complete its action, be moved by the spring 38 into its inactive position, the connecting-rods 24 25 will engage the rock-arms 15 16, and the printing operation will regularly proceed, the cylinders A and B being automatically raised and lowered until the necessity arises for another tripping action, which will be accomplished as has been explained.

In inking up the forms and when repeated failures to properly feed a sheet occur this tripping mechanism may be continued in action for any necessary period.

It is further important that a means shall be provided for raising either impression-cylinder by hand-tripping, so as to remove the cylinders from their printing positions while making the forms ready for printing. This is accomplished by elongating the shafts 10 11, to which the rock-arms 31 32 are secured, so that they protrude beyond or extend conveniently near to the side frame and providing them with hand-levers II P, which, upon being appropriately moved, will rock said shafts to trip and uncouple the rod 24 or 25, thus permitting the toggles to be rocked out of alinement and a cylinder to be raised by the action of the spring 63 or 64; but it is necessary that this hand-tripping shall not occur during the printing period of either cylinder. To govern this hand-tripping a safety-guard N is mounted fast upon the cam-shaft 13, so as to make turn for turn with the impression-cams 26 27 and tripping-cam 30, and it has a rim that is normally opposed to lozenge-shaped studs *o e*, projecting from the sides of the levers II P, which rim is provided with an opening or omitted part so proportioned and related to the cams 26 27 30 as to provide for the passage of the studs *o e* and hence for the hand movement of the levers

H P only during the non-printing movement of the cylinders, at which time the impression-cams 26 27 operate the toggles for the regular printing operation and the cam 30 may trip the toggles.

It will be observed that if the impression-cams 26 27 are alone active the rock-arms 31 32 are not moved, and hence their shafts are not rocked, but when the cam 30 is brought into action by the foot-tripping these arms 31 32, acting through the rock-arms 33 34, rock their shafts 10 11 and throw the levers H P inward, the studs *o* and *e* of which levers are then moved through the opening in said guard and thereafter travel against its inner periphery, as in Fig. 7, until, the cam 30 being free to move sidewise, the normal position of the levers is attained. So, also, when hand-moved the studs of these levers H P will similarly travel within the guard and be appropriately released and restored to their normal positions.

What I claim is—

1. The combination with mechanisms for raising and lowering the impression-cylinders, of rock-arms operating to trip said mechanisms out of action, a revolving tripping-cam having its enlarged part of such relative extent that it can be moved laterally into operative position over said arms but once during each revolution of it, and, means for sliding said cam, substantially as described.

2. The combination with mechanisms for raising and lowering the impression-cylinders, of rock-arms for tripping said mechanisms out of action and a sliding tripping-cam for actuating the arms, the rock-arms being mounted in such positions with relation thereto that said cam can only be moved into engagement with said arms when the low part of the cam is opposite the ends of both of said arms, substantially as described.

3. The combination with mechanisms for raising and lowering the impression-cylinders, of tripping rock-arms for disconnecting said mechanisms and a sliding tripping-cam for actuating the rock-arms, the inner ends of which rock-arms are so related to the cam and the latter is so constructed that during its forward rotation it can only be moved into engagement with the rock-arms after its high part has passed the trip-arm for the secondary cylinder, thus compelling the tripping action to be first performed with respect to the primary cylinder, substantially as described.

4. The combination with mechanisms for raising and lowering the impression-cylinders, of tripping rock-arms for disconnecting said mechanisms and a sliding tripping-cam for actuating said rock-arms, which rock-arms are mounted with their inner ends at one side of the cam-shaft so related to each other and to said cam that during its forward rotation it shall first operate the tripping rock-arm of the primary cylinder and then operate the

tripping rock-arm of the secondary cylinder, substantially as described.

5. The combination with mechanism for raising and lowering an impression-cylinder, of a tripping rock-arm operating to disconnect said mechanism, a tripping-cam for actuating said arm, means for sliding said cam laterally into engagement with the tripping rock-arm and an auxiliary rock-arm moved by the tripping rock-arm to press said cam into and hold it in complete engagement with the tripping rock-arm, substantially as described.

6. The combination with mechanisms for raising and lowering the impression-cylinders, tripping rock-arms operating to disconnect said mechanisms, a tripping-cam for actuating said arms, means for sliding said cam laterally into engagement with the tripping rock-arms, and auxiliary rock-arms respectively moved by the tripping rock-arms to press said cam into and hold it in complete engagement with the tripping rock-arms, substantially as described.

7. The combination with mechanisms for raising and lowering the impression-cylinders and rock-arms operating to trip said mechanisms out of action, of hand-levers independently operative to move said arms, and a rotating guard engaging said levers to control their movements, substantially as described.

8. The combination with mechanism for raising and lowering the impression-cylinders, the tripping rock-arms for disconnecting said mechanisms and the sliding tripping-cam, of the rocking shaft 40, its arms 41, 42, 43, 44, rock-arms 35, 36 and means connecting the arms 35, 36 and 43, 44, substantially as described.

9. The combination with the toggle rock-arms 15, 16 impression-cams, 26, 27 and connecting-rods 24, 25 of the sliding cam 30, rock-arms 31, 33 and 32, 34, substantially as described.

10. The combination with the toggle rock-arms 15, 16, impression-cams 26, 27, and connecting-rods 24, 25, the sliding cam 30, rock-arms 31, 33 and 32, 34, of the rocking shaft 40, its arms 41, 42, 43, 44, rock-arms 35, 36 and rods 45, 46, substantially as described.

11. The combination with mechanisms for raising and lowering the impression-cylinders, rock-arms operating to trip said mechanisms out of action, a revolving tripping-cam coacting with said rock-arms, and a rock-shaft carrying means for sliding said cam into operative position, of intermediate devices connecting said rock-arms and rock-shaft and operating to compel the tripping operation to be completed when once begun, substantially as described.

12. The combination with mechanisms for raising and lowering an impression-cylinder, a rock-arm operating to trip said mechanisms out of action, a revolving tripping-cam co-

acting with said rock-arm, and a rock-shaft  
carrying means for sliding said cam into op-  
erative position, of intermediate devices con-  
necting said rock-arm and rock-shaft and op-  
5 erating to compel a tripping operation to be  
completed when once begun, substantially as  
described.

In testimony whereof I have hereunto set  
my hand in the presence of two subscribing  
witnesses.

STEPHEN D. TUCKER.

Witnesses:

F. W. H. CRANE,  
E. L. SPEIR.