



INTERNATIONAL APPLICATION PUBLISHED UNDER THE PATENT COOPERATION TREATY (PCT)

<p>(51) International Patent Classification ⁶ : A61L 27/00, C12M 3/04</p>	<p>A1</p>	<p>(11) International Publication Number: WO 95/01810 (43) International Publication Date: 19 January 1995 (19.01.95)</p>																		
<p>(21) International Application Number: PCT/GB94/01455 (22) International Filing Date: 5 July 1994 (05.07.94) (30) Priority Data:</p> <table border="0"> <tr> <td>9314057.2</td> <td>7 July 1993 (07.07.93)</td> <td>GB</td> </tr> <tr> <td>9314471.5</td> <td>7 July 1993 (07.07.93)</td> <td>GB</td> </tr> <tr> <td>9314056.4</td> <td>7 July 1993 (07.07.93)</td> <td>GB</td> </tr> <tr> <td>9314580.3</td> <td>14 July 1993 (14.07.93)</td> <td>GB</td> </tr> <tr> <td>9320352.9</td> <td>2 October 1993 (02.10.93)</td> <td>GB</td> </tr> <tr> <td>9320368.5</td> <td>2 October 1993 (02.10.93)</td> <td>GB</td> </tr> </table> <p>(71) Applicant (for all designated States except US): SMITH & NEPHEW PLC [GB/GB]; 2 Temple Place, Victoria Embankment, London WC2R 3BP (GB). (72) Inventors; and (75) Inventors/Applicants (for US only): WOLOWACZ, Sorrel, Elizabeth [GB/GB]; 99 Carr Lane, Acomb, York YO2 5NH (GB). CARTER, Andrew, James [GB/GB]; 80 Debden Road, Saffron Walden, Essex CB11 4 AL (GB). SEARLE, Richard, John [GB/GB]; 12 Fairway Drive, Upper Poppleton, York YO2 6HE (GB). MATTHEWS, Jane, Bridget [GB/GB]; 84 South Bank Avenue, York YO2 1DP (GB). KING, John, B. [GB/GB]; Well Cottage, Chiselhurst Road,</p>		9314057.2	7 July 1993 (07.07.93)	GB	9314471.5	7 July 1993 (07.07.93)	GB	9314056.4	7 July 1993 (07.07.93)	GB	9314580.3	14 July 1993 (14.07.93)	GB	9320352.9	2 October 1993 (02.10.93)	GB	9320368.5	2 October 1993 (02.10.93)	GB	<p>Bromley, Kent BR1 2NW (GB). PALMER, Debra [GB/GB]; Shaftesbury, Ten Acres, Dorset SP7 8PW (GB). (74) Agent: WHITE, Martin; Corporate Patents & Trade Marks Dept., Smith & Nephew Group Research Centre, York Science Park, Heslington, York YO1 5DF (GB). (81) Designated States: AT, AU, BB, BG, BR, BY, CA, CH, CZ, DE, DK, ES, FI, GB, HU, JP, KP, KR, KZ, LK, LU, MG, MN, MW, NL, NO, NZ, PL, PT, RO, RU, SD, SE, SK, UA, US, VN, European patent (AT, BE, CH, DE, DK, ES, FR, GB, GR, IE, IT, LU, MC, NL, PT, SE), OAPI patent (BF, BJ, CF, CG, CI, CM, GA, GN, ML, MR, NE, SN, TD, TG). Published With international search report.</p>
9314057.2	7 July 1993 (07.07.93)	GB																		
9314471.5	7 July 1993 (07.07.93)	GB																		
9314056.4	7 July 1993 (07.07.93)	GB																		
9314580.3	14 July 1993 (14.07.93)	GB																		
9320352.9	2 October 1993 (02.10.93)	GB																		
9320368.5	2 October 1993 (02.10.93)	GB																		
<p>(54) Title: IMPLANTABLE PROSTHESIS, KIT AND DEVICE FOR MANUFACTURING THE SAME</p>																				
<p>(57) Abstract</p> <p>An implantable prosthesis comprises a biocompatible, synthetic, substantially bioresorbable matrix material seeded with fibroblasts.</p>																				

FOR THE PURPOSES OF INFORMATION ONLY

Codes used to identify States party to the PCT on the front pages of pamphlets publishing international applications under the PCT.

AT	Austria	GB	United Kingdom	MR	Mauritania
AU	Australia	GE	Georgia	MW	Malawi
BB	Barbados	GN	Guinea	NE	Niger
BE	Belgium	GR	Greece	NL	Netherlands
BF	Burkina Faso	HU	Hungary	NO	Norway
BG	Bulgaria	IE	Ireland	NZ	New Zealand
BJ	Benin	IT	Italy	PL	Poland
BR	Brazil	JP	Japan	PT	Portugal
BY	Belarus	KE	Kenya	RO	Romania
CA	Canada	KG	Kyrgystan	RU	Russian Federation
CF	Central African Republic	KP	Democratic People's Republic of Korea	SD	Sudan
CG	Congo	KR	Republic of Korea	SE	Sweden
CH	Switzerland	KZ	Kazakhstan	SI	Slovenia
CI	Côte d'Ivoire	LI	Liechtenstein	SK	Slovakia
CM	Cameroon	LU	Luxembourg	SN	Senegal
CN	China	LV	Latvia	TD	Chad
CS	Czechoslovakia	LU	Luxembourg	TG	Togo
CZ	Czech Republic	LV	Latvia	TJ	Tajikistan
DE	Germany	MC	Monaco	TT	Trinidad and Tobago
DK	Denmark	MD	Republic of Moldova	UA	Ukraine
ES	Spain	MG	Madagascar	US	United States of America
FI	Finland	ML	Mali	UZ	Uzbekistan
FR	France	MN	Mongolia	VN	Viet Nam
GA	Gabon				

IMPLANTABLE PROSTHESES, KIT AND DEVICE FOR MANUFACTURING THE SAME

The present invention relates to methods suitable for replacing or repairing broken or damaged connective tissue such as ligaments or tendons and to prostheses for use in such methods. Also disclosed is a device for use in forming such prostheses, as well as kits from which the prostheses can be formed.

It is known from United States Patent No. US5078744 to repair damaged ligaments such as the anterior cruciate ligament (ACL) by replacing part of the damaged ligament by a prosthetic ligament comprising purified connective animal tendon or ligament tissue fibres which are cross-linked and formed into groups of aligned fibres.

The most common method of repair or reconstruction of the ACL is to implant a prosthetic graft comprising autogenous tissues. Thus it is common surgical practice to harvest autogenous tissue eg. patellar tendon from the host and to form a prosthesis for implantation.

A number of synthetic non-bioresorbable materials have been used in the manufacture of prosthetic ligaments, the materials being chosen for their affinity for supporting or encouraging the ingrowth of fibroblasts, after implantation of the prosthesis.

According to the present invention there is provided an implantable prosthesis which, in a form prior to implantation in a host, comprises a biocompatible, synthetic, substantially bioresorbable matrix material seeded with fibroblasts.

By "synthetic", is merely meant a material which is not used naturally by the mammalian body in connective tissue repair or which is not a chemically modified form of such a material. Thus this term excludes collagen and artificially cross-linked collagen matrixes (although, if desired, collagen can be used in addition to the synthetic material).

The term "fibroblast" includes cells which are sometimes referred to as fibroblast, fibrocyte, tenocyte or synovioctye cells. This term also covers precursor cells to any of these cells.

5 By "substantially bioresorbable matrix material" is meant a three dimensional structure for supporting fibroblasts (which may be in the form of a scaffold, mesh or solid structure, for example) and which, in the implanted prosthesis, degrades substantially over time in a mammalian body, due to the chemical/biological action of body
10 components (as opposed to simply breaking due to physical strain on to the prosthesis). Desirably after the prosthesis has been implanted in an adult human for five years (more preferably after only one year's implantation) the bioresorbable material will have degraded to such an extent so that it makes no substantial
15 contribution to the structural integrity of the prosthesis.

Preferably the matrix may additionally comprise one or more of the following molecules: proteoglycans, glycosaminoglycans, fibronectin or its active binding domain, or one or more growth
20 factors e.g. bone morphogenetic protein (BMP) fibroblast growth factor, angiogenesis factor or other stimulatory factors.

In a further embodiment of the invention, the prosthesis or part thereof (e.g. area(s) of the prosthesis which will come into contact
25 with bone after implantation), may be impregnated with osteoinductive or osteoconductive agents, to enable more easy infiltration by bone cells. Examples of suitable osteoinductive materials susceptible to infiltration include hydroxyapatite, freeze-dried or demineralised bone, growth factors (e.g. bone
30 morphogenetic protein) etc. Impregnation may suitably be just before implantation of the prosthesis. Aptly such materials are incorporated into ends of the prosthesis.

In a further embodiment of the present invention, there is
35 provided a method of repairing or replacing damaged connective tissue in a human or non-human animal comprising the steps of: incubating a biocompatible, synthetic, substantially bioresorbable

matrix material in the presence of a suitable culture medium and of fibroblasts under suitable conditions for fibroblast seeding on or in the matrix and thereafter implanting the seeded matrix into a host.

5 Examples of suitable substantially bioresorbable synthetic polymers include polylactide (PLA), polyglycolide (PGA), polydioxanone, poly caprolactone (PCL), polyhydroxybutyrate (ICI BIOPOL™), polyhydroxybutyrate-co-hydroxyvalerate (ICI BIOPOL™), polyanhydrides, polyorthoesters, polyorthocarbonates, 10 polyaminocarbonates, polytrimethylene carbonate and co-polymers incorporating monomers from which the aforesaid polymers can be formed.

 When the prosthesis according to the present invention 15 comprises a copolymer, the copolymer may incorporate hydroxyvalerate and hydroxybutyrate monomers. In such copolymers the amount of hydroxyvalerate present may be from 1 to 47% mol. Other particularly suitable copolymers are PLA/PGA and PLA/PCL copolymers.

20

 Composites of a plurality the above substantially bioresorbable materials may also be suitable as or as part of the matrix material.

 The matrix be fabricated of two or more distinct materials (e.g. 25 distinct fibre types) with different degradation rates, providing a two or more phase loss of mechanical properties with time. Also, the different fibre types may possess different mechanical properties. For example, highly extendable fibres may be combined with less extendable fibres. The matrix may be designed to elongate to a 30 specified extent before the less extendable fibres prevent further extension. This design may be advantageous in exposing the cells to limited and controlled strain while protecting against damage to the forming tissue. For example, polycaprolactone fibres have a lower Young's modulus than polylactide fibres.

35

 Furthermore, one polymer may be coated with another polymer. This is advantageous where the material of choice on the

basis of mechanical properties is not necessarily the material of choice for cell culture (unless it is modified). Here a more biocompatible polymer may be used to coat a less biocompatible base material. For example, polylactide provides a better substrate for fibroblast proliferation than polycaprolactone. Polycaprolactone fibres could be coated with polylactide to improve compatibility with fibroblasts.

As indicated above, copolymeric materials may be used. This can be advantageous where the copolymers possess degradation rates intermediate between the rates of the homopolymers of which they are composed. Therefore, the degradation rate may be controlled by controlling the composition of the copolymer. Also, production of copolymer fibres by fibre spinning or extrusion may yield fibres with mechanical properties superior to those of homopolymers. Polylactide-Polyglycolide copolymers are good examples of both of these points.

Suitable fibroblasts for use in seeding the matrix may be autogenic fibroblasts, allogenic fibroblasts or xenogenic fibroblasts. Preferably, the fibroblasts are autogenic. The fibroblasts may originate from for example the dermis, tendons or ligaments. The fibroblasts for use in seeding the matrix may comprise a mixture of one or more of the above types of fibroblasts. Where the fibroblasts are autogenic, it is preferable to isolate them from the dermis, as this avoids the need for extensive invasive surgery.

The fibroblasts may be obtained according to any suitable method. A preferred method is by carrying out a skin biopsy.

The matrix material may be seeded with fibroblasts by placing the matrix in a culture vessel containing an appropriate culture medium (e.g. DMEM), in the presence of fibroblasts and incubating under cell culture conditions. The fibroblasts may be suspended in the culture medium and the resultant suspension added to the culture vessel either before or after addition of the matrix. The

number of fibroblasts/ml of medium may be varied according to the degree of seeding it is desired to establish.

5 The prosthesis of the present invention may be used to either partially or totally replace a damaged ligament, tendon, cornea, dermis, dura (or other body part comprising connective tissue). Where the damage is substantial, the damaged ligament or tendon may be totally surgically replaced by the prosthesis. Where the damage is less substantial the matrix may be designed so as to be
10 joined (e.g. by suturing) to the existing damaged ligament or tendon.

The matrix may be designed according to any one of a number of possibilities. Aptly the matrix is a fibrous structure. It may have loops or other structures at each end for aiding fixation to bone
15 (using for example either the "two tunnel" or the "over-the-top" technique). It may be formed by any appropriate technique - e.g. braiding, knitting, weaving, crocheting etc. The matrix is desirably in elongate form and is preferably flexible.

20 The device may closely mimic the natural structure and fixation of the ligament or tendon. For example, for ACL reconstruction, the device could be composed of a hierarchy of fibres bundled together in fascicular units, passing directly from the femur to the tibia or taking a spiral path around the axis of the device. Fixation may be to
25 the natural fixation areas of the ligament or tendon. Any appropriate fixation means may be used (e.g. screws, nails, staples or sutines). The fixation means may itself be bioresorbable, for example it may be formed of polyhydroxybutyrate.

30 The present invention further provides a kit for forming the prosthesis of the present invention comprising a synthetic biocompatible matrix material and a source of fibroblasts.

35 On incubation under suitable conditions, the fibroblasts will grow on and/or in the matrix, thus producing a matrix seeded with fibroblasts.

The kit may additionally comprise a suitable medium for the proliferation of fibroblasts.

5 Ideally the kit is presented in a sterile package. Alternatively the parts of the kit may be sterilised just before use. Prior to implantation, the components of the kit can be incubated together under appropriate culture conditions as above described to allow the fibroblasts to seed the prosthesis.

10 The fibroblasts may be in any suitable form ready for use. Thus aptly the fibroblasts may be cryopreserved.

The matrix, or components/precursors thereof, may be provided in lyophilised form.

15 In a preferred embodiment, the present invention comprises, an implantable prosthesis which in a form prior to implantation comprises a biocompatible synthetic substantially bioresorbable matrix material having a polymeric gel in intimate contact therewith, the gel having fibroblasts dispersed therein. This is advantageous in that the gel can support the cells in a true three-dimensional arrangement rather than merely supporting a monolayer on the surface of a material. The environment closely mimics the natural physiological environment of the cells. Also, incorporation of cells in a gel can provide for even cell distribution, preventing cells from pooling which might otherwise occur due to gravitational influence.

20 The present invention provides a method of repairing or replacing connective tissue in a human or other animal, comprising the steps of: incubating a biocompatible matrix material in the presence of a gel-forming composition and of fibroblasts under suitable conditions to form a prosthesis comprising a matrix contacting a polymeric gel, the gel having fibroblasts dispersed therein, and thereafter implanting the prosthesis into a host.

35 Suitable gel forming compositions include collagen gel forming compositions and fibrin gel forming compositions.

Fibroblasts in a collagen gel are capable of utilising the collagen and reorganising it. Under an appropriate mechanical stimulus they are capable of reorganising the fibrils into non-
5 randomly orientated, organised structures resembling the natural ultrastructure of ligament and tendons. A mechanical stimulus may be the prevention of gel contraction which would otherwise occur over time by fixing the gel at two points. The matrix may be designed to achieve this. Alternatively, the gel on or in the matrix
10 may be exposed to applied strain using a mechanised straining device to stimulate fibroblast alignment.

The method may comprise an additional step of incubating a gel-contacting matrix under suitable conditions for fibroblast
15 proliferation in the gel and thereafter implanting the matrix into a host.

In the preferred embodiment of the present invention, the matrix is seeded by means of incubating the matrix in the presence
20 of a suitable culture medium, a gel-forming composition and the fibroblasts to be seeded. An appropriate agent for causing gelation of the gel forming composition may also be used, if necessary.

Seeding the matrix in the presence of a gel-forming
25 composition, fibroblasts (and a gelling agent, if required) results in a gel-coated or filled matrix, the gel having fibroblasts dispersed therein. The gel can be formed by the interaction of the gelling agent and the gel-forming composition. A preferred gel is a collagen gel. A Type I, II or III collagen solution may be prepared using an
30 appropriate source of collagen. Thus for example a Type I collagen solution may be prepared from dermis (Type I collagen forms up to 70% of extracellular protein found in skin) as above described. Alternatively a Type I collagen solution may be prepared tendons, e.g. rat or bovine tendons, which comprise almost exclusively Type
35 1 collagen. The collagen may be extracted according to any of the standard methods known by those skilled in the art.

There are a number of suitable ways of incorporating the gel in or on the matrix. For example, the matrix may be suspended in such a manner that the gel-forming solution (optionally comprising fibroblasts) completely surrounds the matrix. A mould which surrounds the matrix may be used. Centrifugation or suction may alternatively be used to direct gel towards the matrix.

A kit for use in forming the prosthesis of the preferred embodiment can comprise a biocompatible matrix, a gel-forming composition and a source of fibroblasts.

Alternatively the kit may comprise a biocompatible matrix having a coating comprising a polymeric gel and/or having a polymeric gel incorporated therein and a source of fibroblasts. On incubation under suitable conditions the fibroblasts can invade the gel, thus producing a matrix bearing a gel having fibroblasts therein.

The prosthesis of the present invention offers an advantage over previously known prostheses which were designed to enhance ingrowth of fibroblasts after implantation and act as a scaffold through which fibroblasts can grow and form a new ligament, since it comprises fibroblasts prior to implantation. Thus the damaged tissue may be replaced by a prosthesis comprising viable fibroblasts which may be replicating. The fibroblasts may already substantially be aligned on implantation or at least oriented in a non-random manner. This process is speedier than previously known methods which rely on infiltration of prostheses by fibroblasts after implantation. It will be clear that the prosthesis may be implanted after an initial predetermined incubation period timed to result in seeding of the prosthesis with fibroblasts. Alternatively the prosthesis may be incubated for a longer incubation period than the initial incubation period so that the fibroblasts will be replicating and will have already started to secrete collagen fibrils when the prosthesis is implanted.

35

The prosthesis and method of the present invention offers other advantages over the common surgical practice or harvesting

host patellar tendon in that it avoids the need for carrying out an extensive surgical operation to harvest the tendon. A simple skin biopsy (a standard procedure which does not result in substantial scarring) can be used to obtain fibroblasts which can then be
5 proliferated in culture. In addition, the prosthesis can be designed to optimise fibroblast orientation. The cumulative effect of these advantages can result in a reduction in the length of a hospital stay.

10 In one preferred embodiment of the present invention, where a collagen gel contacts the matrix, the prosthesis of the present invention provides a source of collagen which can be used by the fibroblasts. The collagen in the gel is preferably in a non-cross-linked form.

15 In another preferred embodiment of the present invention a fibrin gel is used.

20 According to a further aspect of the present invention there is provided a device for culturing cells for use in forming a prosthesis according to the present invention, comprising a chamber for maintaining fibroblasts in a viable condition, the chamber being provided with means for releasably securing the matrix material and means adapted for applying strain to the matrix material along a single axis only. Such a device can be included in a kit as aforesaid.

25 If several straining means are present, the device of the present invention can apply strain to a plurality of samples at any one time. Thus the device may have one or more chambers adapted to retain a culture medium and may be provided with means for
30 releasably securing a plurality of matrix materials. This may be done simultaneously. Each of several chambers may be provided with means for releasably securing a plurality of matrix materials. Alternatively each chamber may be provided with means for releasably securing a single matrix material.

35 A chamber may be permanently fixed within the device. Alternatively the chamber may be releasably fixed so that it may be

removed from the device as desired, e.g. the chamber(s) may be removed to facilitate the securing and release of the matrix material.

5 A chamber may be made from any material which may be sterilised by suitable methods of sterilisation, e.g. gamma irradiation, steam sterilisation or ethylene oxide (ETO) sterilisation.

10 A chamber may have any desirable shape and size. Suitably the chamber may be cylindrical, cuboid or spherical. The dimensions of the chamber should be such that they enable the matrix material to be secured and to be subsequently extended on the application of strain. The device of the present invention can be adapted to apply a strain which causes e.g. up to 100% extension of the matrix material (relative to the material in unextended form).
15 Generally speaking however, an extension of up to 10%, or of up to 5% may be sufficient.

20 Thus the dimensions of the chamber can be such that they enable the matrix material to be extended to the desired level.

The dimensions of a chamber are desirably such that the chamber has a capacity of up to 75cm³, e.g. up to 50cm³. The chamber may be made from any suitable material, e.g. stainless steel or Perspex™ material. Preferably the material is autoclavable
25 to facilitate sterilisation.

30 Preferably the chamber is provided with a transparent or translucent window to enable the matrix material to be viewed during the time of culture. Examples of suitable materials include glass and polymethylmethacrylate (PERSPEX).

35 The chamber may comprise a closure, which may be removably or hingedly mounted to allow access to the inside of the chamber. Thus for example the chamber may comprise a glass cylinder wherein at least one of the ends is removable. Aply the chamber may be collapsible or telescopic.

The chamber is desirably thermostatically controlled and may be heated via a water jacket or other heating means. It may be provided with various sensors e.g. sensors of the CO₂ content within a head space of the chamber. A CO₂ source may also be provided.

The matrix material may be releasably secured by securing means within the chamber.

The means for applying strain may compare two elements which are movable within the chamber so that the spacing between the elements can be varied. Alternatively one element may be movable but the other may be fixed.

The securing means may be any suitable means for releasably securing the matrix sample. The design of the securing means depends upon the design of the ends of the matrix material. Thus for example where the matrix material comprises looped ends the securing means may comprise a pair of clips or hooks. Suitably the securing means may comprise for example a chuck or a lathe or jaws which may screw together or be held by springs. Aptly the securing means may be in the form of a slot or other opening such that the ends of the matrix material are designed to fit thereon. Thus for example the ends of the matrix material may be embedded in a resin which may be retained in a slot. The opposite arrangement can be used in which the opening is in the matrix material and the securing means fit therein. A yet further way of releasably securing the matrix material is to provide a spool, which may be generally cylindrical, about which matrix material can be wrapped and held in position by friction. The spool may be held in place by a gripping device. Two such spools may be provided - one for each of two gripping devices.

The matrix material to which strain is to be applied by the device of the present invention may comprise any suitable material for supporting viable cells. Cells may be present in or along the entire length of the matrix material. Alternatively part of the matrix

material, e.g. the ends thereof, may have no cells. The cells may be applied to the matrix material either before or after the matrix material has been secured under extension. It is preferable however to apply the cells to the material before securing the material under extension in the chamber.

The matrix material may be designed in the form of a prosthetic ligament or tendon. Where for example the matrix material is in the form of a prosthetic ligament, the ligament when unstrained is preferably in the range of from 1 to 30cm long. The matrix material should be chosen so that it is suitable for withstanding the magnitudes of strain which it will be subjected to on implantation, e.g. in the knee.

The means for applying strain may act by pulling both ends or one end of the matrix material, resulting in an extension of the matrix material. This may be done by various means, e.g. mechanical, electrochemical, electrical, piezoelectric, pneumatic, hydraulic or other means. The matrix material may be releasably attached to a stationary element at one end of the chamber and the opposing end of the matrix material may be attached to a tension applying member (for example a winding device). Suitably strain may be applied to the matrix material by means of a diaphragm, one side of the diaphragm lying within the chamber and the opposing side lying outside the chamber. A pivotally mounted lever may be used to apply strain.

The present invention also provides a method of culturing cells under strain which method comprises the steps of releasably securing a matrix material having viable cells in intimate contact therewith in a chamber, the chamber comprising an adequate amount of culture medium to cover the matrix and cells, and applying strain to the matrix material along a single axis.

Materials suitable for use in a matrix of the present invention can be assessed as exemplified below:-

Assessment of Materials

5

In order to make an initial assessment of suitable materials for supporting fibroblast growth, various materials were obtained (which are not to be construed as limiting), as indicated in Table 1 below, and moulded into films for 5min at 2.5 Tons at the following
 10 temperatures: Polylactide 170°C; polyglycolide, 245°C; polyhydroxybutyrate, 185°C; and polycaprolactone, 65°C.

Table 1

15	<u>Material</u>	<u>Supplier</u>	<u>Fig.</u>
	Polylactide	Medisorb, Cincinnati, Ohio, USA	1a
	Polyglycolide	Medisorb, Cincinnati, Ohio, USA	1b
	Polyhydroxybutyrate	Goodfellows, Cambridge, UK	1c
20	Polycaprolactone	Birmingham Polymers Inc. Alabama, USA	1d

Fibroblasts were seeded onto the surfaces of these materials at a density of 1×10^4 cells/cm² of material and incubated for 3
 25 days under culture conditions.

After the incubation period, photomicrographs were taken of the cell-seeded samples. These are shown in Figs. 1a to 1d for the samples indicated in Table 1 above (photocopies of all of the
 30 photographs provided for this application are provided immediately after the relevant photographs).

Fibroblasts can be seen to be well adhered to the surfaces of all of the materials and to exhibit the morphology typical of healthy
 35 cultural fibroblasts.

One sample of fibroblasts was grown on polylactide as described above apart from the fact that a longer (16 day) culture period was used.

5 After this period the cells were stained with a viable stain (calcein AM (2 μ M)) and visualised by fluorescence microscopy using a fluorescein filter. A confluent monolayer of viable cells was observed, showing that polylactide is capable of supporting viable fibroblasts for extended periods of culture.

10

Figure 2 is a graph showing the relative rate of proliferation of fibroblasts on four examples of bioresorbable synthetic materials: polylactide (PLA); polyglycolide (PGA) polyhydroxybutyrate (PHB) and polycaprolactone (PCL) (all as described above) in comparison with a tissue culture treated polystyrene (TCP) control (since TCP is known to support good fibroblast growth).

15

Figures 2a) to e) show each of these materials on a single graph (for each of reference). Cells were seeded at 1×10^4 cells.cm⁻² in triplicate and the rate of proliferation determined by measuring the uptake of tritiated thymidine into cellular DNA at timepoints up to 7 days after incubation using standard cell culture techniques. The medium was changed at 2, 4 and 6 days. The points represent the mean of three determinations and the error bars represent the range. All polymers supported fibroblast proliferation.

20

25

Figure 3 is a photomicrograph of fibroblasts embedded within a three dimensional collagen gel after 15 days of culture. The cell-seeded gel was prepared as described in example 2 (which will be described later) apart from the fact that it was not used to contact a matrix. The gel provides a three-dimensional structure in which the cells are embedded and can form interactions with collagen molecules via membrane integrin receptors. The cells are randomly arranged, exhibit long processes and are capable of reorganising collagen fibrils within the gel.

30

35

Figure 4 is a photomicrograph of fibroblasts embedded within a three dimensional collagen gel as described for Fig. 3 above, apart from the fact that the gel has now been constrained from contracting in one direction by two stainless steel pegs glued to a culture dish with a tissue culture compatible adhesive. The cells are arranged in a highly orientated fashion, their long axes being parallel to the axis between the contraining pegs. The collagen fibrils align along the same axis. This effect is due to the pegs preventing the gel contracting, as would otherwise occur in the presence of fibroblasts in culture.

The following examples, which are not to be construed as limiting, illustrate how various cell-seeded matrixes can be produced.

5

Example 1 : Preparation of a fibroblast seeded polylactide matrix prosthesis

a) Preparation of Cells

10

A biopsy is washed three times in phosphate buffered saline (PBS), and rinsed in 70% alcohol. The rinsed biopsy is then dipped into Dulbecco's Modified Essential Medium (DMEM) and incubated at 37°C for 24 hours. After incubation, the biopsy is cut into small pieces under PBS. The cut pieces are transferred to a 50mm petri dish, containing about 5ml of collagenase solution to allow digestion. The epidermal sheets are removed from the collagenase solution. The resultant solution is centrifuged. The fibroblast cell pellet is resuspended in DMEM and thereafter seeded in a 35mm petri dish using DMEM. The cells may be confluent in from 2-4 days. Thereafter the cells may be cultured to provide an appropriate quantity of fibroblasts for seeding the matrix.

A suitable medium for culturing the isolated fibroblasts may comprise DMEM which may be supplemented with the following: glutamine, foetal calf serum, non essential amino acids and antibiotics. In addition the medium may have a buffering agent such as bicarbonate.

30 b) Preparation of matrix material

A polylactide matrix material suitable for use in a prosthesis for replacing a ligament can be prepared by obtaining polylactide fibres and then braiding them to form a braid of appropriate dimensions to replace the ligament.

35

Poly lactide fibres can be obtained by extrusion, fibre spinning, melt-spinning, drawing, heat annealing etc.

Braiding of the fibres can be done by standard braiding techniques, the length and thickness of the braid, number of fibres present and diameter of fibres present being selected to form a braid with appropriate properties.

The ends of the device are constructed in a suitable way to aid fixation of the device by a screw or other fixation means. This is done by forming eyelets at the ends.

10

c) Seeding of matrix material with cells

The braided device is incubated in a medium containing 10% v/v serum for 24 hours and is then seeded with cells by pipetting a cell suspension over the surface of the matrix material until the latter is completely covered with cell suspension. (Alternatively the matrix may be incubated together with the cell suspension for a period of about six hours under conditions of agitation, e.g. on a bottle roller. Other alternatives are to seed the device by sucking cell suspension through it under vacuum (if it is porous) or by centrifuging cell suspension through the device).

20

d) Straining of the cell-seeded matrix

The cell seeded device is gripped at both ends in a straining apparatus which causes the device to be strained along a single longitudinal axis. This is done for sufficient time so as to cause the fibroblasts substantially to align along the general direction of the longitudinal axis, as can be assessed by microscopic analysis of the cells. The apparatus comprises a culture chamber so that straining can occur over several hours or even several days and yet the cells can remain viable. Typically the device is strained at 37°C.

30

During straining a culture medium is used to culture the cells under suitable conditions. This includes serum, ascorbate or stable analogues thereof, together with growth factors.

35

The ascorbate stimulates the fibroblasts to synthesise collagen; the serum contains factors promoting cell proliferation and cell adherence and the growth factors can stimulate cell proliferation, development and migration.

5

e) Implantation of the cell-seeded matrix

Once the cell-seeded device has been strained for a sufficient period to obtain a desired degree of alignment of fibroblasts, it is removed from the cell-straining device and implanted into a patient by any desired technique.

Minimal invasive surgery is preferred. For a prosthetic anterior cruciate ligament implantation be done utilising the "two-tunnel" or the "over the top" techniques. Fixation can be achieved by using screws (or other fixation elements) placed through the eyelets of the matrix. The screws are suitably formed of a biodegradable material, such as polyhydroxybutyrate.

10
15

Example 2 : Preparation of a fibroblast seeded polylactide matrix prosthesis comprising a collagen gel in which the fibroblasts are incorporated

5

This can be done in an analogous manner to the method described in Example 1, except for the inclusion of an alternative procedure whereby fibroblasts are incorporated in a collagen gel which is used to seed the polylactide matrix. This extra procedure is described below:-

10

a) Preparation of collagen

It is desired to form the collagen in a form which is acid soluble and which is not cross-linked. This can be done as follows:-

15

Type I collagen is prepared from tendon but could be from other tissue e.g. skin. The tissue is minced finely, disinfected in 70% (v/v) ethanol for at least 30 mins, dispersed in acetic acid (1% v/v) and incubated with agitation at 4°C. The supernatant is removed and neutralised by addition of an appropriate volume of 1.0M sodium hydroxide. The precipitated type I collagen is pelleted by centrifugation at 8,000 x g and the pellet resuspended in an appropriate volume of acetic acid (1% v/v). The collagen concentration of this solution is determined by any appropriate method (e.g. a total protein assay - the BCA assay) and the concentration of the collagen solution adjusted appropriately (e.g. 3mg.ml⁻¹ can be used).

20

25

If the product is a kit, sterile collagen solution may be lyophilised and stored under vacuum or an inert gas (e.g. argon) to prevent cross-linking. A diluent (acetic acid) could also be provided. Alternatively, it could be provided as a solution and stored at 4°C to -20°C.

30

b) Seeding of matrix material with cells

Three components are typically used to seed the matrix:- cells
5 suspended in an appropriate medium, collagen solution and a
gelling agent - (e.g. 1M sodium hydroxide). The final collagen
concentration may be approximately $1\text{mg}\cdot\text{ml}^{-1}$ and the seeding
density approx. 3×10^4 cells per ml of gel (or volume within the
matrix). The three components are maintained at 0°C to 4°C , mixed
10 and added to the matrix. Once the matrix is fully impregnated, it is
incubated at 37°C and gelling is initiated.

The impregnation of the matrix may be achieved by any
suitable method. The matrix may be merely immersed in the solution
15 within a mould. Alternatively the solution may be sucked into the
scaffold by use of a vacuum or forced in by centrifugation (for
example within a mould centrifuged at 500rpm for 5min at $0-4^\circ\text{C}$).

The rate of setting of the gel may be varied by varying the
20 temperature.

Example 3 : Preparation of a fibroblast seeded polylactide matrix prosthesis comprising a fibrin gel in which the fibroblasts are incorporated

5

This can be done by an analogous method to that described in Example 2, except that a fibrin gel rather than a collagen gel is used.

10 Again, three components are used: cell suspension, fibrinogen solution and thrombin solution containing calcium chloride (mM). The final cell concentration may be 3×10^4 cells per ml, the fibrinogen concentration may be 3mg/ml, the thrombin activity 2.5 Units/ml and the calcium chloride concentration 5mM. The reagents
15 are mixed and then incubated with the matrix. Once impregnated with the solution, the matrix is incubated at 37°C to allow rapid gelling. Impregnation of the matrix may be conducted by any of the techniques described above.

20 The rate of gelling may be varied by varying the thrombin activity and/or the temperature.

The cell straining device referred to previously will now be described by way of example only with reference to Figs. 5 a), b), c), d), and e) which show various components which can be put
5 together to form the device.

The device comprises a Perspex™ container 10 (shown in cut-away section) and lid 20 (see Figs. 5a) and 5e)). Container 10 can be used to contain an extensible material seeded with fibroblasts
10 under cell culture conditions. For ease of reference thermostats, sensors, inlets for topping up culture media and other components which would be well known to those skilled in the art are not shown.

The device further comprises first and second grips 30 and 40, each of which has two parallel arms 45 bearing pegs 50 (see Figs. 5c) and e)).
15

One of the grips (grip 40) is provided with a support 60 which can be moved towards or away from the other grip 30 along a single longitudinal axis by a motor (not shown). The other grip 30 is fixedly
20 mounted to an end wall 35 of the device.

The grips 30 and 40 function to receive and hold spools 70 and 80 (see Figs. 5c) and 5e)). This is achieved by pegs 50 fitting
25 into grooves 90, thereby attaching the spools 70 and 80 to grips 30 and 40 in a manner which prevents rotation of the spools 70 and 80 relative to the grips 30 and 40 respectively.

Spools 70 and 80 function to hold an extensible material seeded with fibroblasts, indicated by cell seeded polylactide braid prosthesis 100.
30

This is achieved by threading opposite ends of the prosthesis 100 through apertures 110 and 120 and then rotating the spools 70 and 80 several times about axes A and B respectively so that the prosthesis 100 is secured to the spools 70 and 80 by friction (see Fig. 5b).
35

The spools 70 and 80 can then be slotted onto grips 30 and 40 as aforesaid (see Fig. 5c) and the prosthesis 100 can be extended by causing support 60 to retract within the container so that grips 30 and 40 become increasingly spaced. Once a desired degree of extension has been achieved support 60 can be held in position by a releasable locking device (not shown) and the extended prosthesis 100 can be incubated under culture conditions for as long as desired.

10

In order that the prosthesis 100 can be easily seen a window 130 is provided formed of a transparent or translucent material. This can be used for microscopic analysis of fibroblasts growing on the prosthesis 100 in order to determine when the prosthesis 100 is ready for implantation.

15

A grooved transparent or translucent block 140 is also provided for positioning at the bottom of container 10 (see Fig. 5d). The block is sized so that groove 150 can accommodate sufficient culture medium to cover the prosthesis 100 when positioned on spools 70 and 80 with the spools 70 and 80 being held by grips 30 and 40. This enables economical amounts of culture medium to be used.

20

The materials used to form the components of the straining device are autoclavable and sterilisable with alcohol. Typically the device is operated at a temperature of 37°C and with an atmosphere of 5% CO₂.

25

30

CLAIMS

1. An implantable prosthesis which in a form prior to implantation
5 comprises a biocompatible, synthetic, substantially bioresorbable
matrix material seeded with fibroblasts.
2. A prosthesis according to claim 1 wherein the bioresorbable
matrix material comprises a polylactide, a polyglycolide, a
10 polydioxanone, a poly caprolactone, a polyhydroxybutyrate, a
polyhydroxybutyrate-co-hydroxyvalerate, a polyanhydride, a
polyorthoester, a polyorthocarbonate, a polyaminocarbonate, a
polytrimethylene carbonate or a co-polymer which incorporates
monomers from which the abovementioned polymers are formed.
15
3. A prosthesis according to claim 1 or claim 2, further comprising
a non-bioresorbable matrix material.
4. A prosthesis according to claim 3 wherein the non-
20 bioresorbable matrix material is a polyester, a polyethylene, a
polypropylene, PTFE, carbon fibre, or a composite of two or more of
the aforesaid materials.
5. A prosthesis according to any preceding claims wherein the
25 matrix further comprise one or more of the following:- proteoglycans,
glycosaminoglycans, fibronectin or its active binding domain,
growth factors, osteoinductive or osteoconductive materials.
6. A prosthesis according to any preceding claim wherein the
30 prosthesis comprises a gel in intimate contact with the bioresorbable
matrix material, the gel having fibroblasts dispersed therein.
7. A prosthesis according to claim 6, wherein the gel is a collagen
or fibrin gel.
35
8. A prosthesis according to claim 7 wherein the gel is in the form
of a coating and/or a filling.

9. A prosthesis according to any of claims 6 to 8, wherein the bioresorbable matrix material is polyhydroxybutyrate or a copolymer incorporating a plurality of hydroxybutyrate monomers.
- 5
10. A prosthesis according to any preceding claim wherein the matrix is flexible.
11. A prosthesis according to any preceding claim which is in the form of a fibrous member.
- 10
12. A prosthesis according to any preceding claim which is in the form of a woven, knitted, crocheted or braided member.
13. A prosthesis according to any preceding claim comprising a plurality of bioresorbable matrix materials having different rates of bioresorbtion.
- 15
14. A prosthesis according to any preceding claim, wherein the fibroblasts are non-randomly oriented.
- 20
15. A prosthesis according to claim 14 wherein the fibroblasts are substantially aligned.
16. A kit for producing a prosthesis according to claim 1 comprising a fibroblast cell source or a device adapted for extracting fibroblasts from a mammalian body and a bioresorbable matrix material.
- 25
17. A kit for producing a prosthesis according to claim 6 comprising a fibroblast cell source or a device adapted for extracting fibroblasts from a mammalian body, a bioresorbable matrix material and a polymeric gel or a composition for forming the polymeric gel.
- 30
18. A device for use in manufacturing a prosthesis according to claim 14 or claim 15, wherein the device comprises a chamber for maintaining fibroblasts in a viable condition, the chamber being
- 35

provided with means for releasably securing the matrix material and means adapted for applying strain to the matrix material along a single axis only.

5

19. A method of repairing or replacing damaged connective tissue in a human or animal, comprising incubating a biocompatible synthetic substantially bioresorbable matrix material in the presence of a suitable culture medium and of fibroblasts under suitable conditions for fibroblast seeding on or in the matrix and thereafter
10 implanting the matrix seeded with fibroblasts into a host.

20. A method according to claim 19 further comprising the step of applying strain to the matrix material when seeded with fibroblasts
15 so as to cause non-random orientation of the fibroblasts.

21. A method according to claim 19 wherein the non-random orientation is a substantial alignment of fibroblasts.

20 22. A method according to claim 20 or claim 21 wherein the fibroblasts are incorporated in a gel.

23. A method according to claim 22 wherein the gel is a collagen gel or a fibrin gel.

Fig. 1a

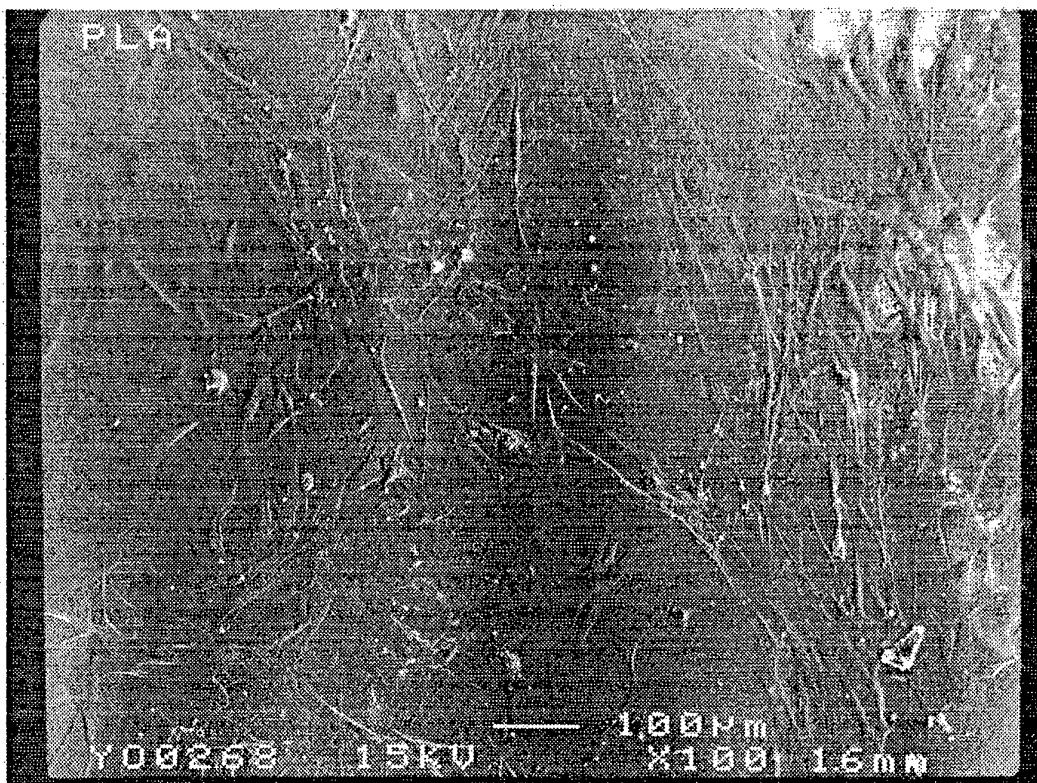

Fig 1b

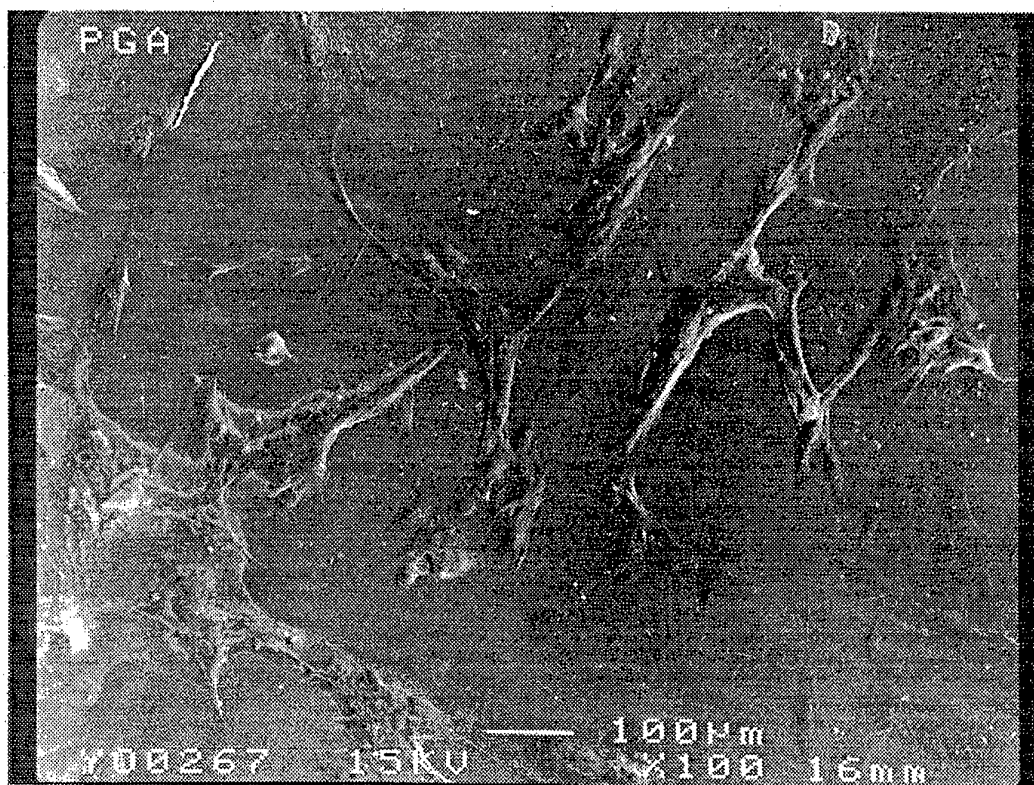

Fig 1c

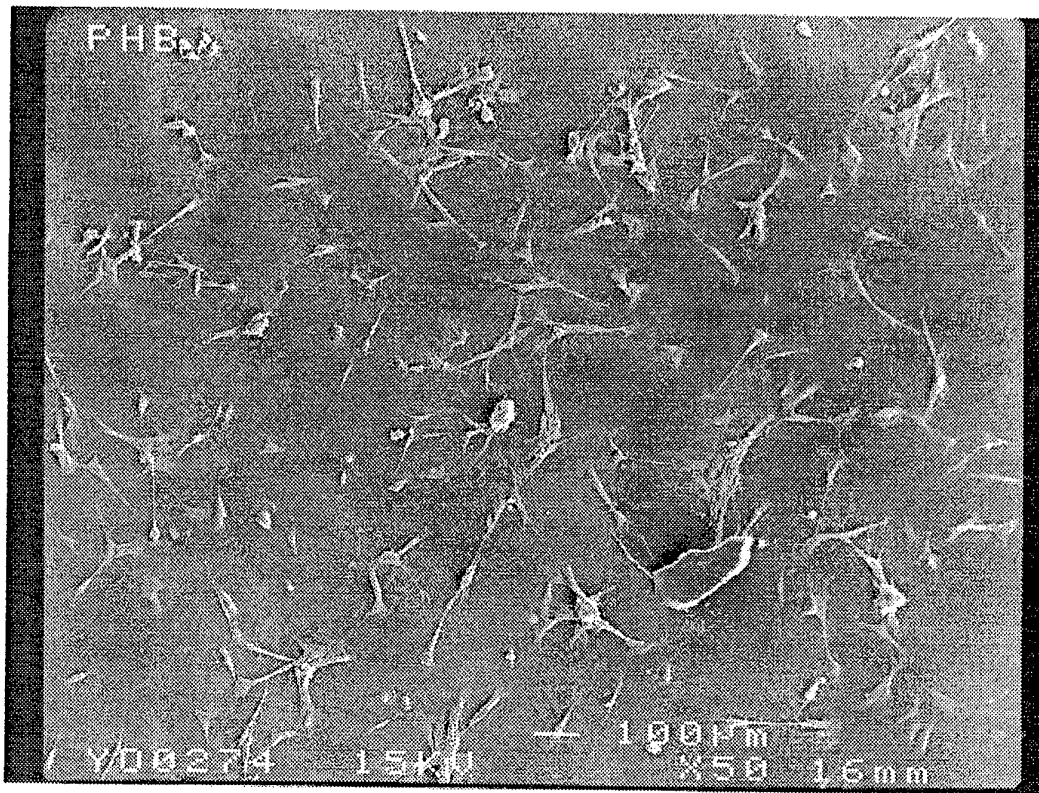

Fig 1d

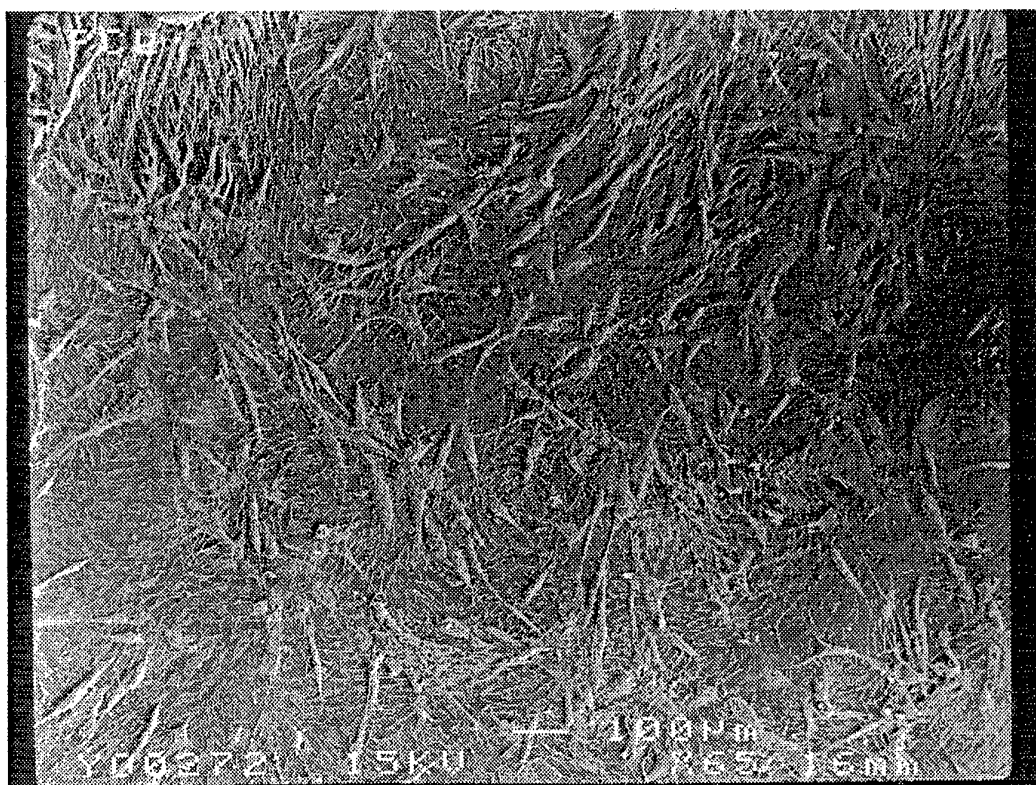

Fig 2a

Cell Proliferation on Tissue Culture Plastic

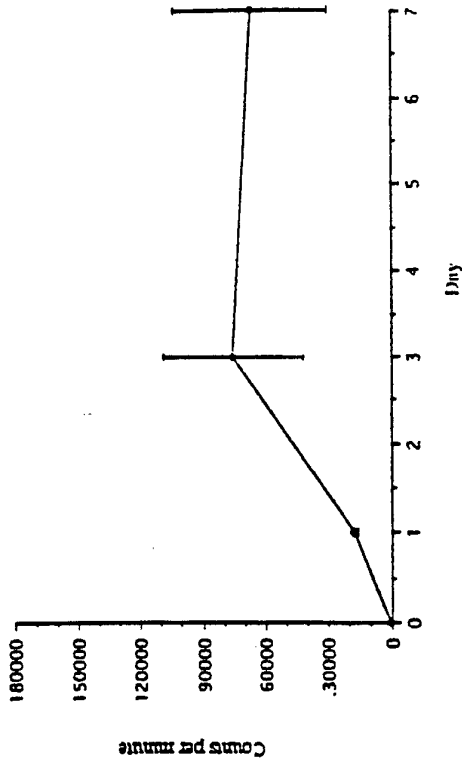

Fig 2c

Cell Proliferation on PHB

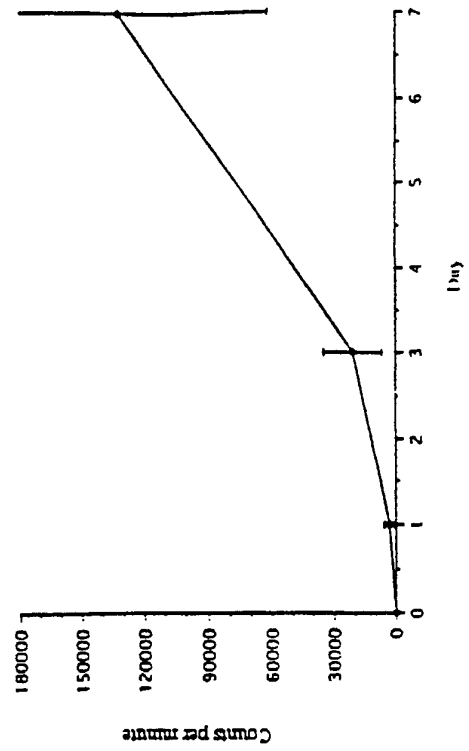

Fig 2

Cell Proliferation on a Range of Polymers

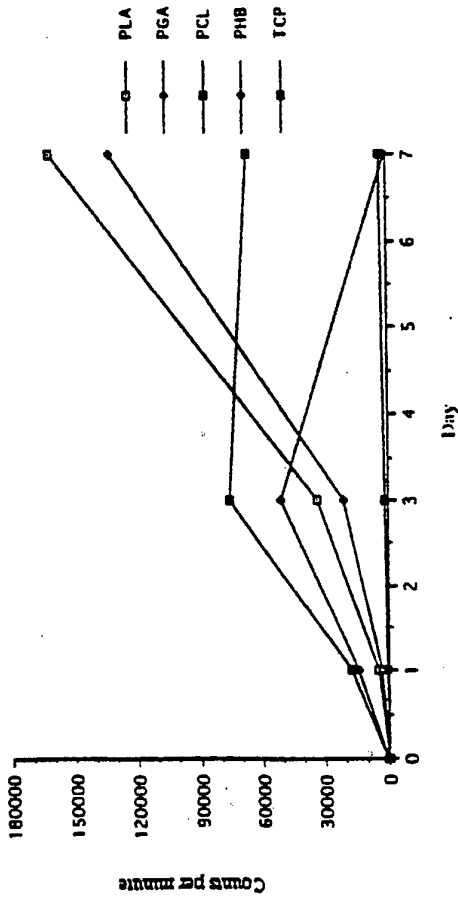
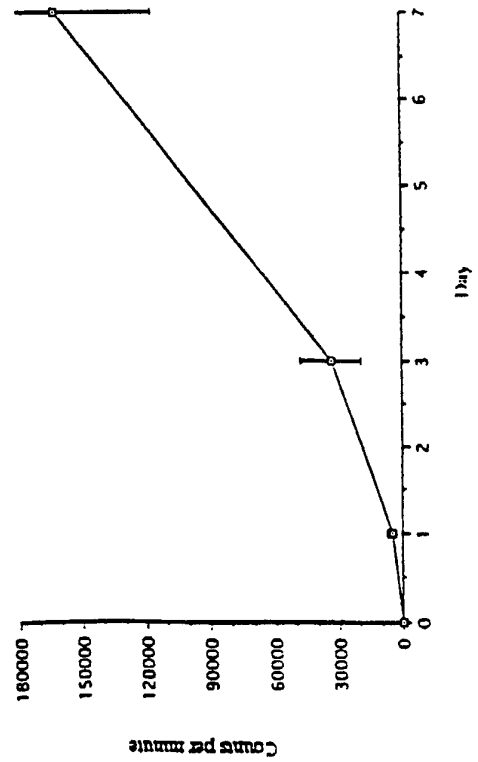
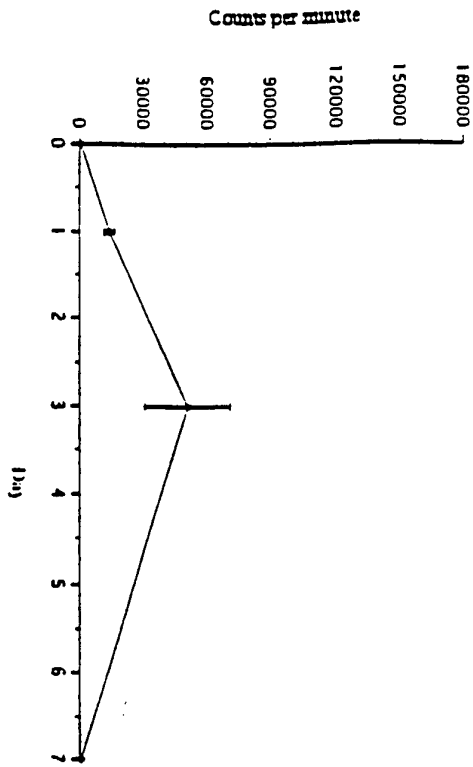

Fig 2b

Cell Proliferation on PLA



6/9



Cell Proliferation on FIGA

Fig 2d.

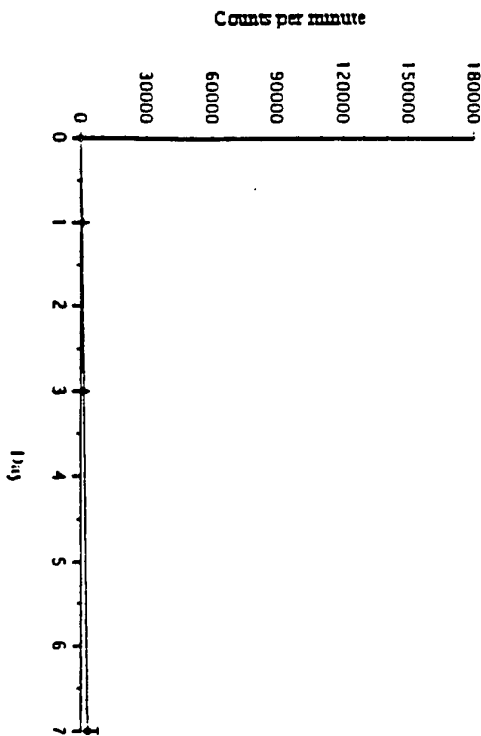

Cell Proliferation on PCT.

Fig 2e

Fig 3

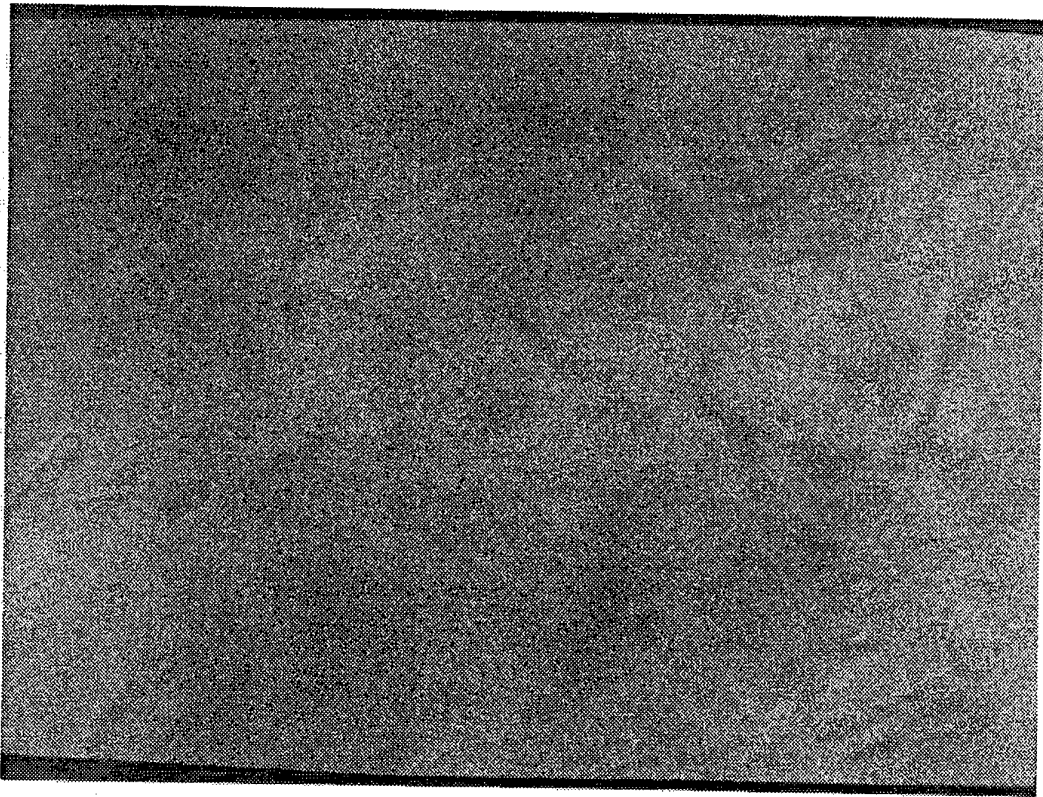
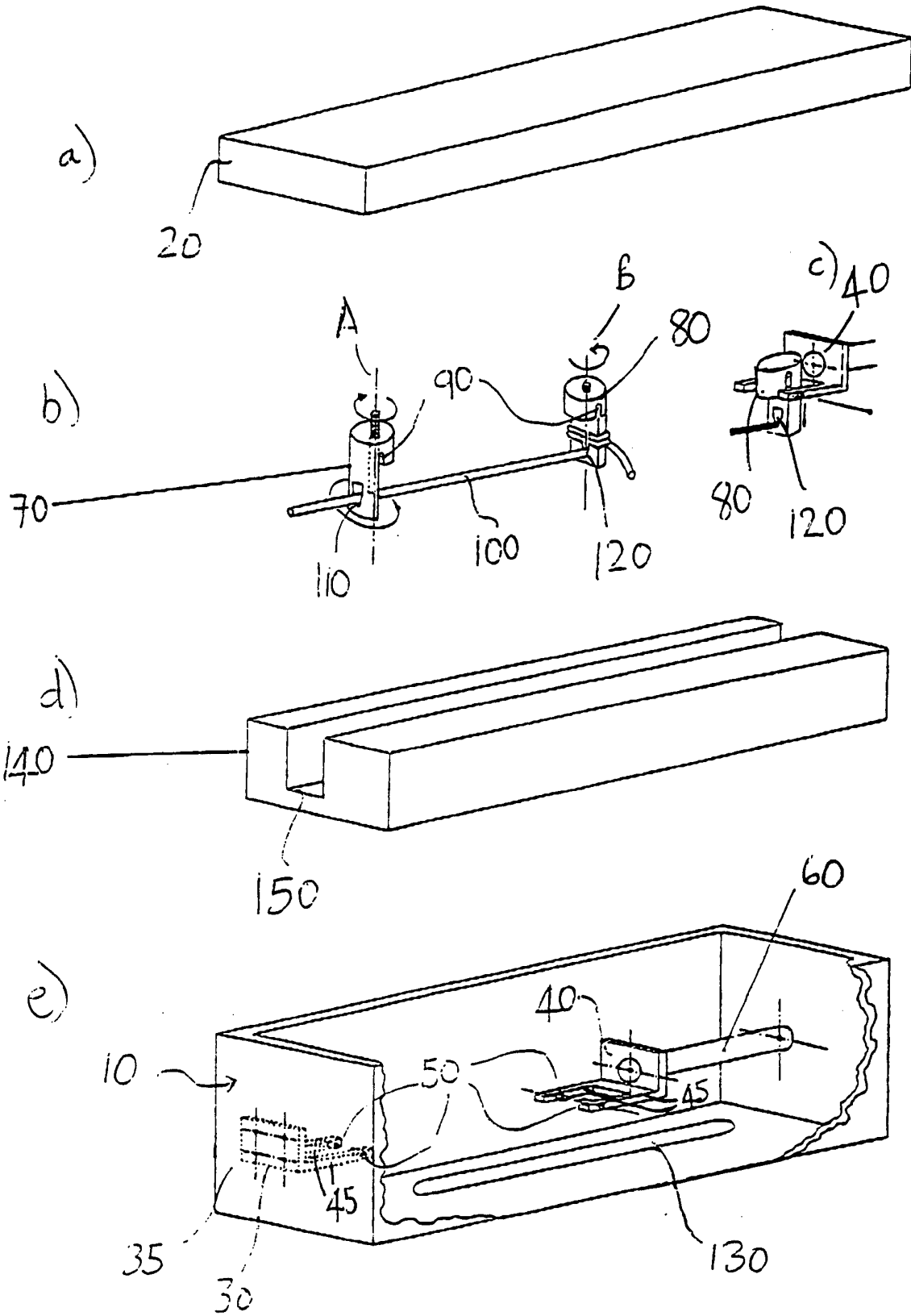

FIG 4



Fig 5



INTERNATIONAL SEARCH REPORT

International application No.
PCT/GB 94/01455

A. CLASSIFICATION OF SUBJECT MATTER
IPC 6 A61L27/00 C12M3/04

According to International Patent Classification (IPC) or to both national classification and IPC

B. FIELDS SEARCHED

Minimum documentation searched (classification system followed by classification symbols)
IPC 6 A61L C12M

Documentation searched other than minimum documentation to the extent that such documents are included in the fields searched

Electronic data base consulted during the international search (name of data base and, where practical, search terms used)

C. DOCUMENTS CONSIDERED TO BE RELEVANT

Category*	Citation of document, with indication, where appropriate, of the relevant passages	Relevant to claim No.
X	WO,A,90 12603 (VACANTI, JOSEPH, P. ET AL.) 1 November 1990 see page 6, line 9 - line 28 see page 8, line 13 - line 33 see page 11, line 23 - line 35 ---	1-15
X	WO,A,88 03785 (VACANTI JOSEPH, P. ET AL.) 2 June 1988 see page 22, line 14 - line 28; claims ---	1-3
X	WO,A,85 04185 (CAPLAN, ARNOLD, I.) 26 September 1985 see claims ---	1
Y	WO,A,92 15259 (COLORADO STATE UNIVERSITY RESEARCH FOUNDATION.) 17 September 1992 see claims ---	1-23
	-/--	

Further documents are listed in the continuation of box C.

Patent family members are listed in annex.

* Special categories of cited documents :

- "A" document defining the general state of the art which is not considered to be of particular relevance
- "E" earlier document but published on or after the international filing date
- "L" document which may throw doubts on priority claim(s) or which is cited to establish the publication date of another citation or other special reason (as specified)
- "O" document referring to an oral disclosure, use, exhibition or other means
- "P" document published prior to the international filing date but later than the priority date claimed

- "T" later document published after the international filing date or priority date and not in conflict with the application but cited to understand the principle or theory underlying the invention
- "X" document of particular relevance; the claimed invention cannot be considered novel or cannot be considered to involve an inventive step when the document is taken alone
- "Y" document of particular relevance; the claimed invention cannot be considered to involve an inventive step when the document is combined with one or more other such documents, such combination being obvious to a person skilled in the art.
- "&" document member of the same patent family

Date of the actual completion of the international search

12 October 1994

Date of mailing of the international search report

28. 10. 94

Name and mailing address of the ISA

European Patent Office, P.B. 5818 Patentlaan 2
NL - 2280 HV Rijswijk
Tel. (+ 31-70) 340-2040, Tx. 31 651 epo nl,
Fax: (+ 31-70) 340-3016

Authorized officer

ESPINOSA, M

INTERNATIONAL SEARCH REPORT

International application No.
PCT/GB 94/01455

C.(Continuation) DOCUMENTS CONSIDERED TO BE RELEVANT

Category *	Citation of document, with indication, where appropriate, of the relevant passages	Relevant to claim No.
Y	WO,A,93 07913 (CHILDREN'S MEDICAL CENTER CORPORATION.) 29 April 1993 see claims ---	1-23
P,Y	WO,A,93 19701 (BAXTER INTERNATIONAL INC.) 14 October 1993 see examples 1-3 ---	1-23
A	WO,A,93 08850 (MASSACHUSETTS INSTITUTE OF TECHNOLOGY) 13 May 1993 see page 8, line 3 - line 26; claims -----	1

INTERNATIONAL SEARCH REPORT

International application No.

PCT/GB94/01455

Box I Observations where certain claims were found unsearchable (Continuation of item 1 of first sheet)

This international search report has not been established in respect of certain claims under Article 17(2)(a) for the following reasons:

1. Claims Nos.: 19-23
because they relate to subject matter not required to be searched by this Authority, namely:
Remark: Although claims 19-23 are directed to a method of treatment of the human/animal body, the search has been carried out and based on the alleged effects of the compound/composition.
2. Claims Nos.:
because they relate to parts of the international application that do not comply with the prescribed requirements to such an extent that no meaningful international search can be carried out, specifically:
3. Claims Nos.:
because they are dependent claims and are not drafted in accordance with the second and third sentences of Rule 6.4(a).

Box II Observations where unity of invention is lacking (Continuation of item 2 of first sheet)

This International Searching Authority found multiple inventions in this international application, as follows:

1. As all required additional search fees were timely paid by the applicant, this international search report covers all searchable claims.
2. As all searchable claims could be searched without effort justifying an additional fee, this Authority did not invite payment of any additional fee.
3. As only some of the required additional search fees were timely paid by the applicant, this international search report covers only those claims for which fees were paid, specifically claims Nos.:
4. No required additional search fees were timely paid by the applicant. Consequently, this international search report is restricted to the invention first mentioned in the claims; it is covered by claims Nos.:

Remark on Protest

- The additional search fees were accompanied by the applicant's protest.
- No protest accompanied the payment of additional search fees.

INTERNATIONAL SEARCH REPORT

Information on patent family members

International application No.
PCT/GB 94/01455

Patent document cited in search report	Publication date	Patent family member(s)	Publication date
WO-A-9012603	01-11-90	US-A- 5041138	20-08-91
		AU-B- 635025	11-03-93
		AU-A- 5556890	16-11-90
		CA-A- 2051663	18-10-90
		EP-A- 0469070	05-02-92
		JP-B- 6006155	26-01-94
		JP-T- 4505717	08-10-92
WO-A-8803785	02-06-88	EP-A- 0299010	18-01-89
		JP-T- 1501362	18-05-89
		US-A- 5041138	20-08-91
WO-A-8504185	26-09-85	US-A- 4609551	02-09-86
		AU-A- 4153985	11-10-85
		EP-A- 0175762	02-04-86
WO-A-9215259	17-09-92	US-A- 5192312	09-03-93
		AU-A- 1577792	06-10-92
		CA-A- 2105478	06-09-92
		EP-A- 0574527	22-12-93
WO-A-9307913	29-04-93	AU-A- 2900792	21-05-93
WO-A-9319701	14-10-93	NONE	
WO-A-9308850	13-05-93	CA-A- 2121040	13-05-93
		EP-A- 0610423	17-08-94