

(19)
(12)

(KR)
(A)

(51) 。 Int. Cl. ⁷
F16L 19/00

(11)
(43)

2001 - 0062888
2001 07 09

(21) 10 - 1999 - 0059630
(22) 1999 12 21

(71) 7 10

(72) 7 10

(74)
:

(54)

가

가

3) (1) (6) (8) , (2) (9)가 ((4)(5) (A)

4

,가 , , , , .

2

3

4

5

6

7 가

8, 9

[]

1: 2: 3:

4,5: 6,11: 7,10:

8: 9: 12:

14: A: B:

D:

가 가 ,

가 , ,

(H) 1 (S) 2 (F) T (F)

가

가

2

가

가

가

3
6

(A)
(D)

5

(1)

(2)

(A)

(4)(5)

(3)

(3)

(6)

(7)

(8)

(9)가

7

(3)

(8)

(4)(5)

(3)

(2)

4

(11)
2)

(10)

(3)

(8)

(1

3
(14)

4

(1)

(A)

(3)

(3)

(A)

(13)

(4)(5)

(14)

(8)

9 8
(70)

(14)

가

5~10mm

(3)

(4)(5)

6

(B)

(D)

(B)

(3)

4)(5)

5 (4)(5) (3) (2) , (1) (3)

7 (3) (8) ,
C C
가 가
가 가 , ,
가 가

(57)

1.

(3) (6) (7) (8) , (9)가
(1) (1) (11) , (2) (A)
(8) (12) (4)(5) (10)

2.

(1) (13) (14) 가 (8)
(70) (3) (14) (14) (4)(5)

3.

1 (3) (8)

1

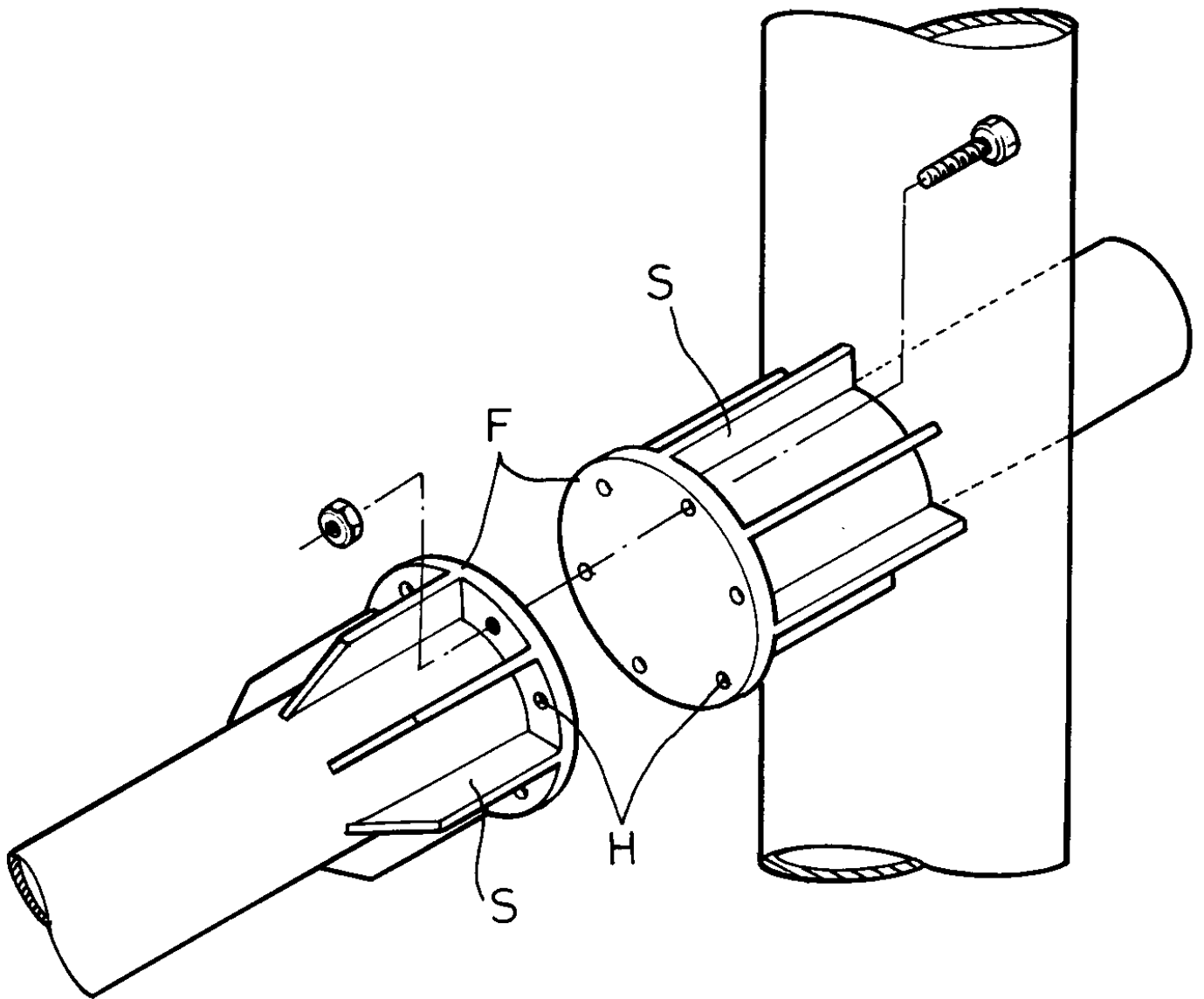

2

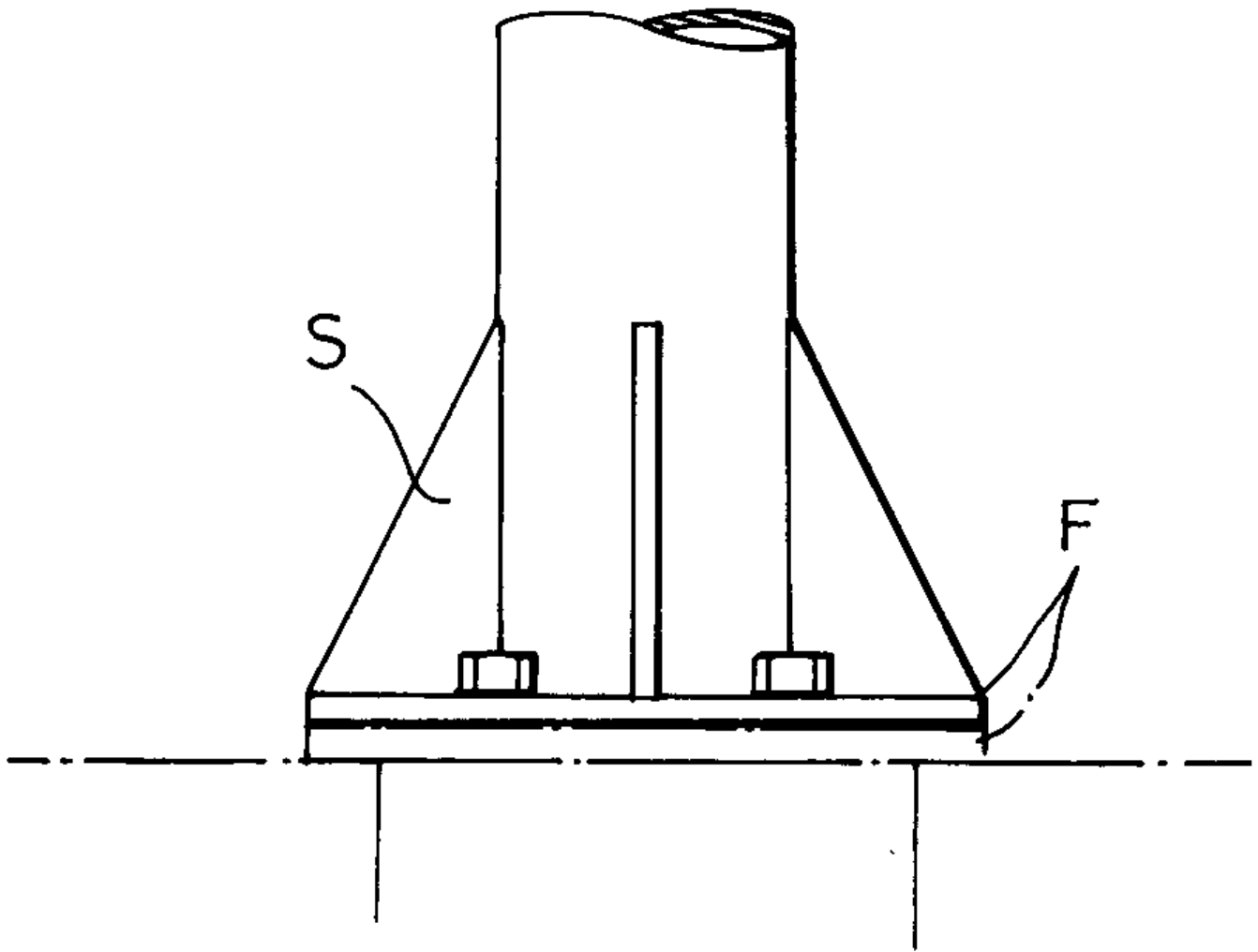

3

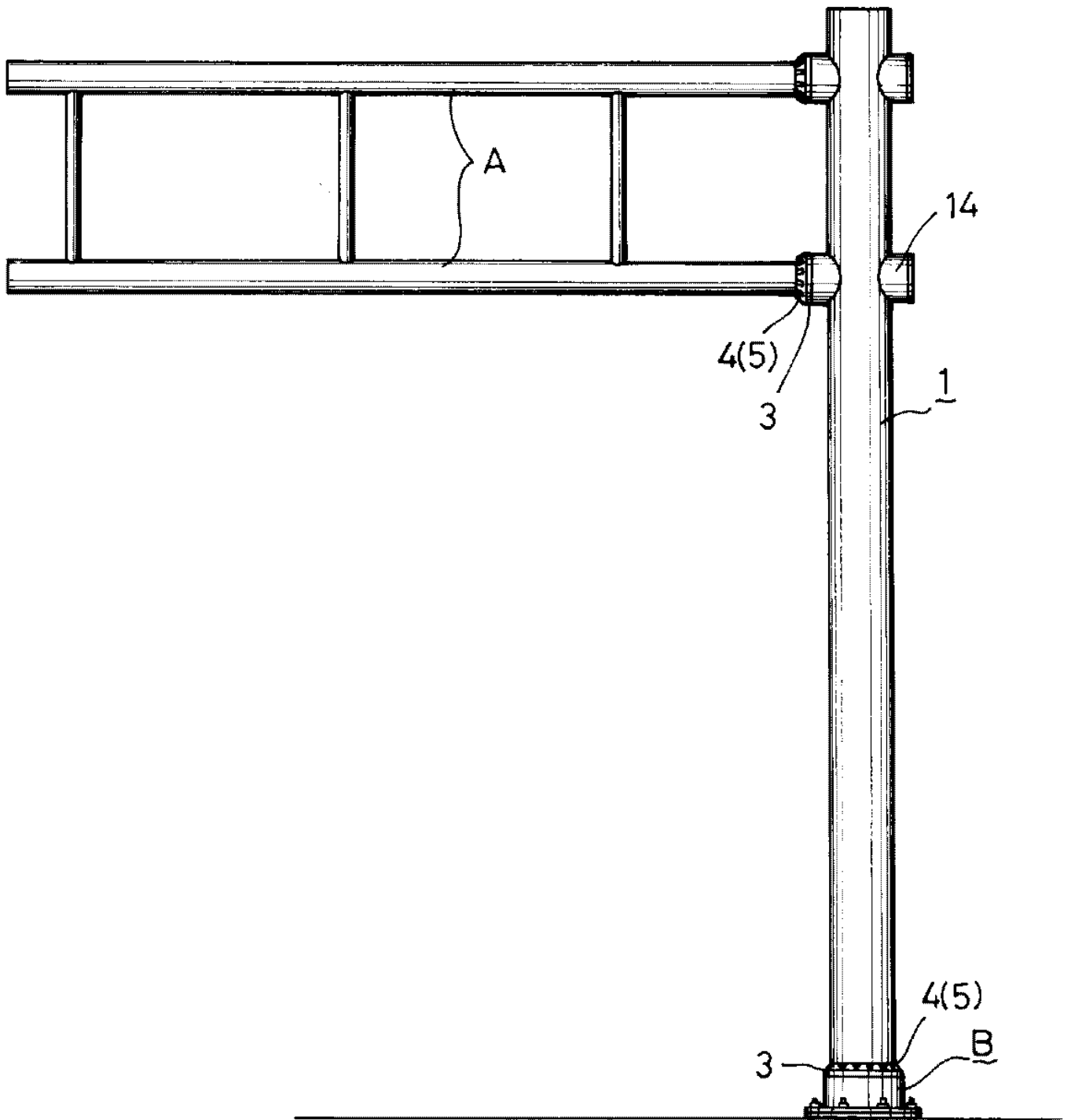

4

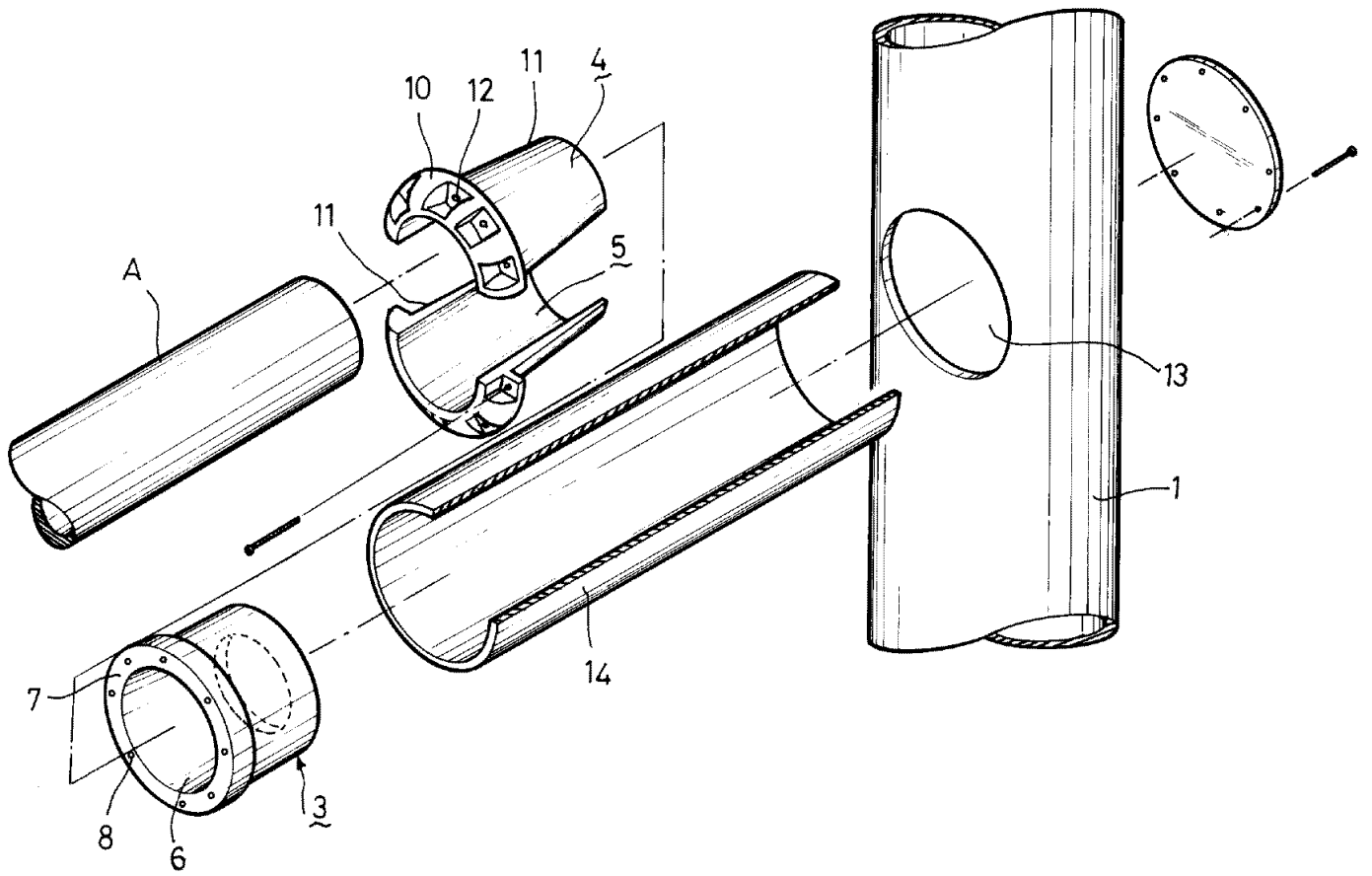

5

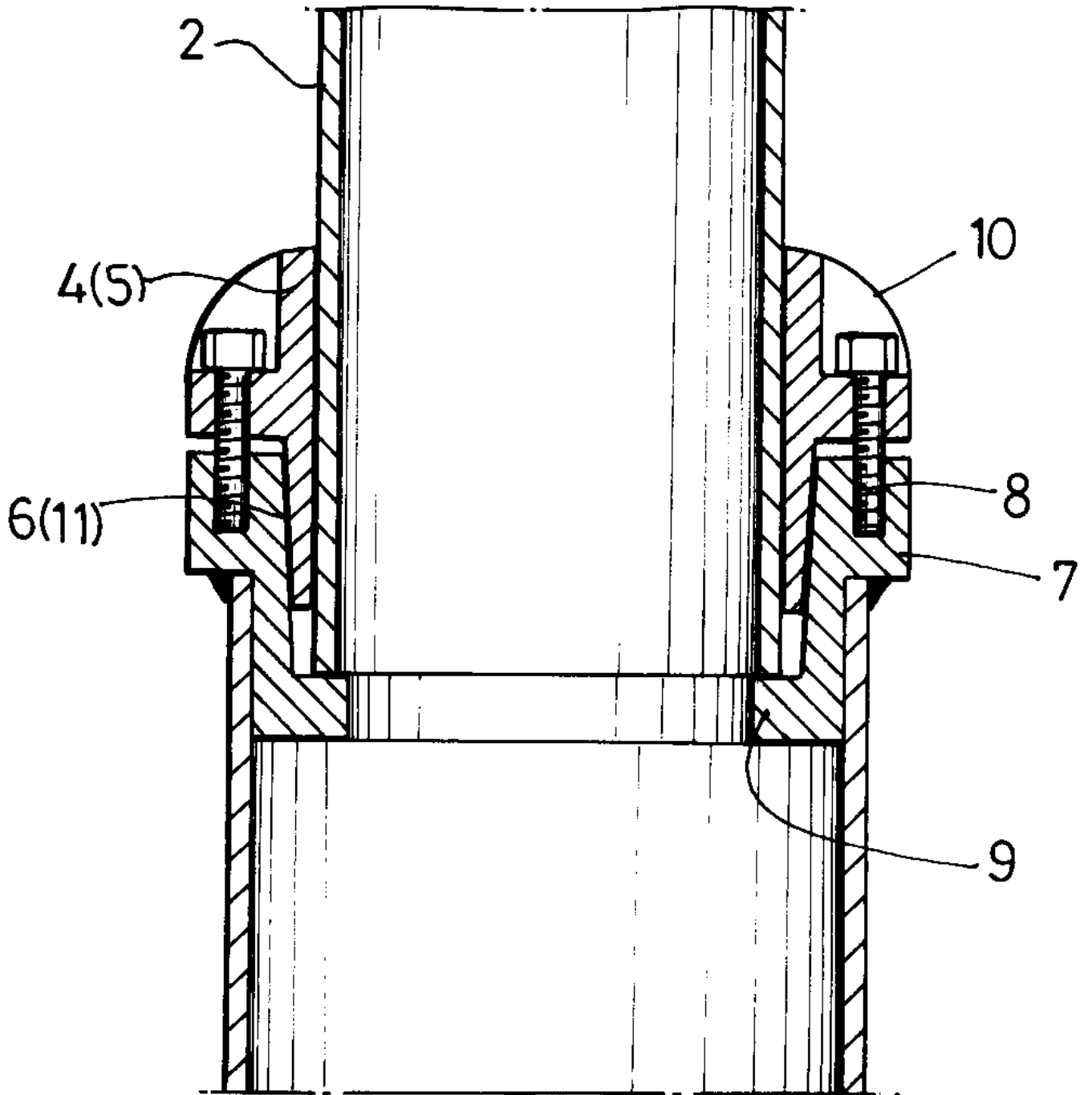

6

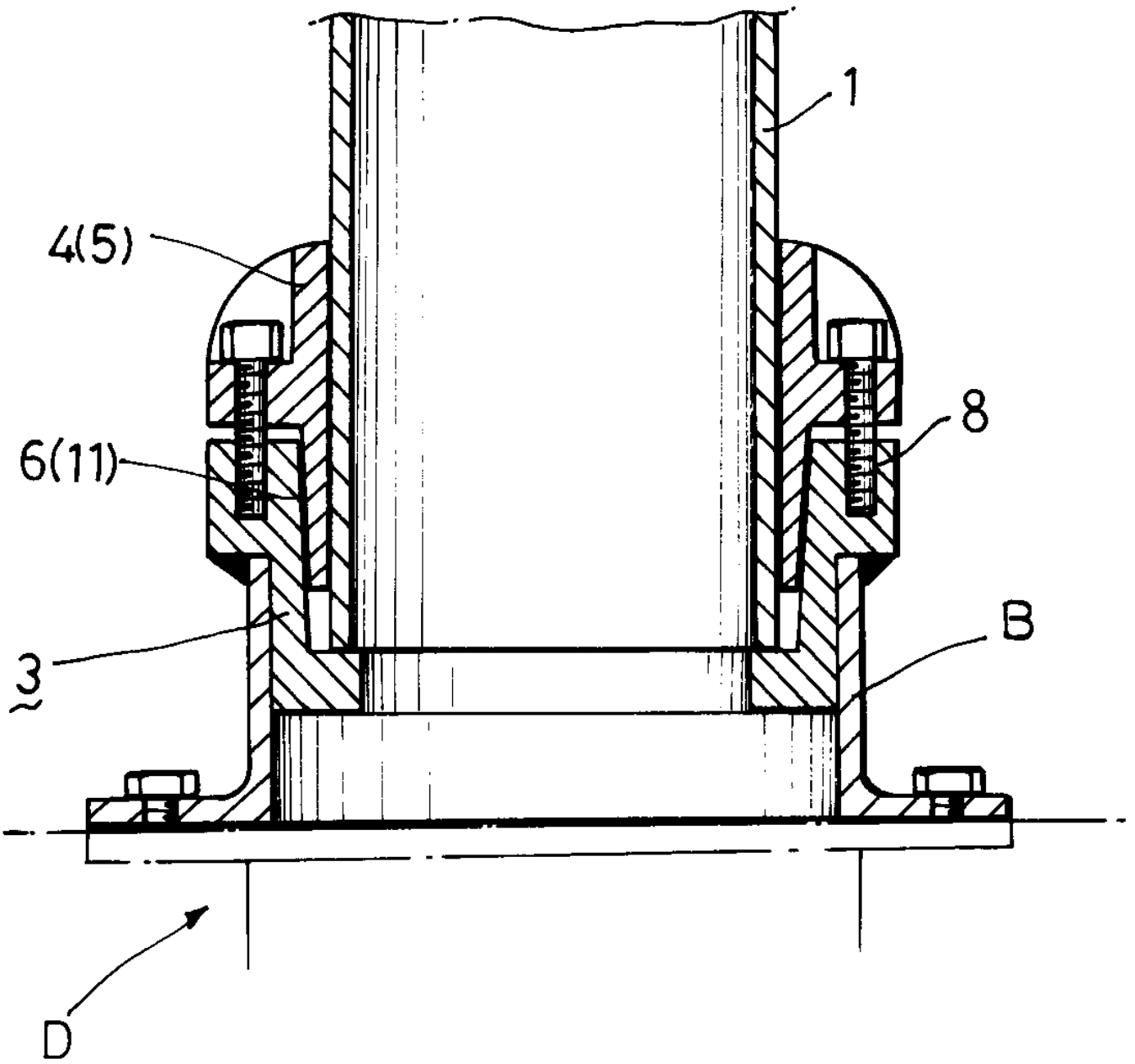

7

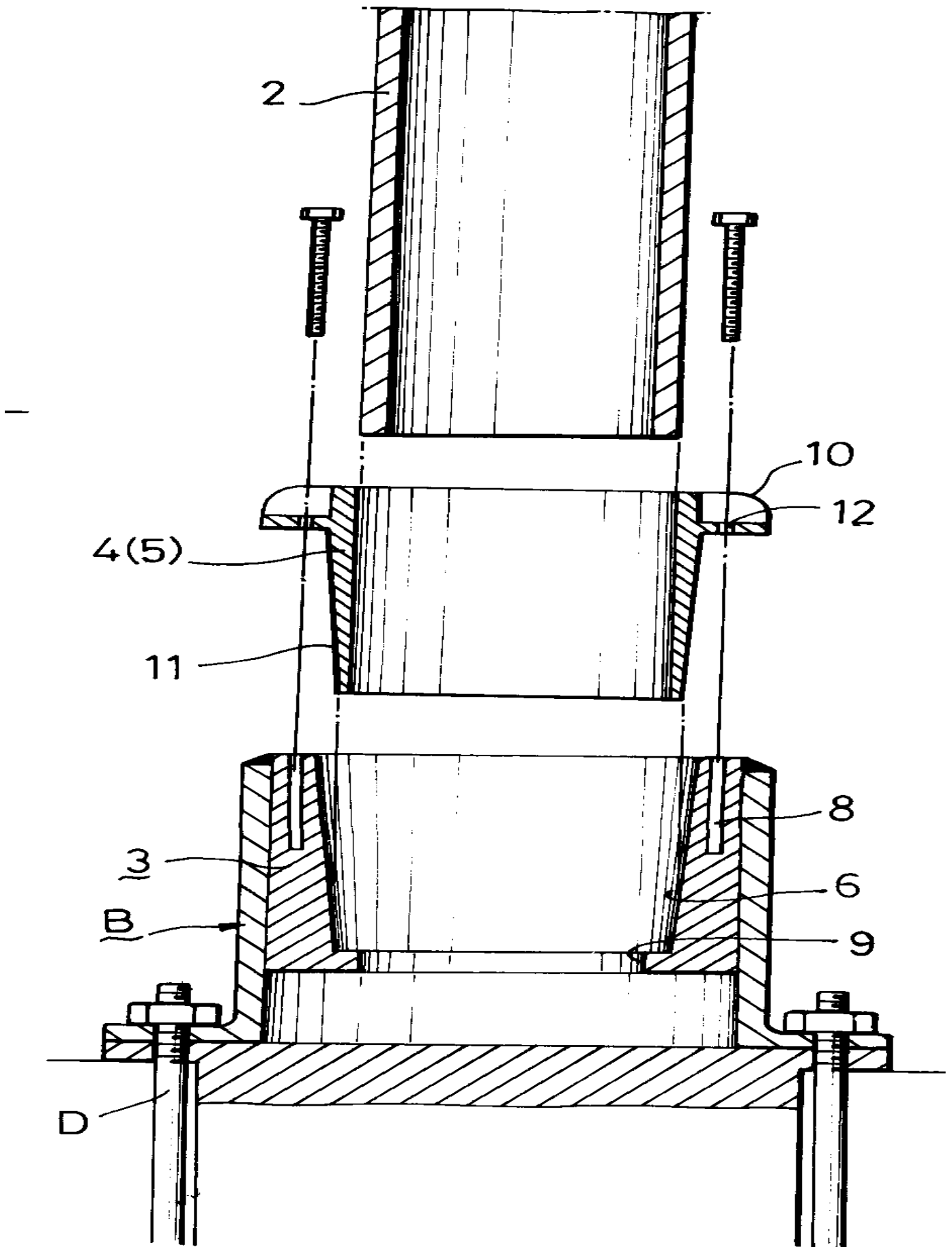

8

