

No. 796,837.

PATENTED AUG. 8, 1905.

J. FLORENCE.  
SLIVER CONDENSER FOR CARDING MACHINES.

APPLICATION FILED FEB. 2, 1905.

2 SHEETS—SHEET 1.

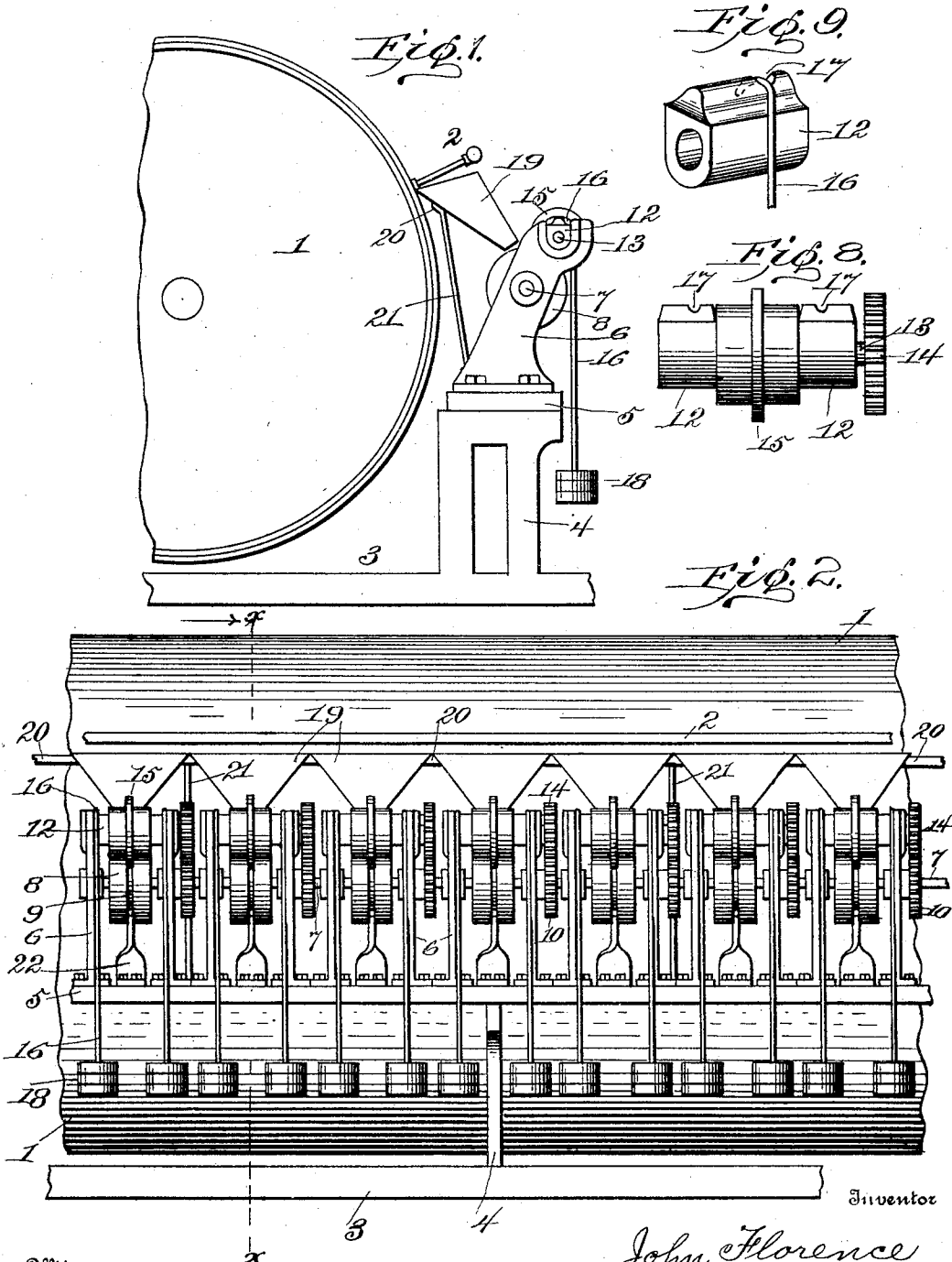

Witnesses  
*L. E. Money*  
*W. F. Crossman*

Inventor  
*John Florence*  
 By *C. J. Peck*  
 Attorney

No. 796,837.

PATENTED AUG. 8, 1905.

J. FLORENCE.  
SLIVER CONDENSER FOR CARDING MACHINES.

APPLICATION FILED FEB. 2, 1905.

2 SHEETS—SHEET 2.

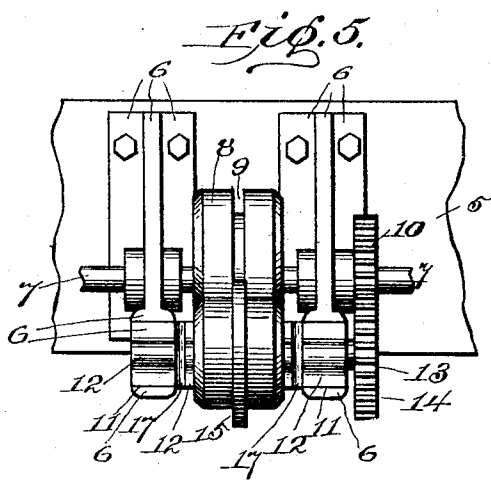
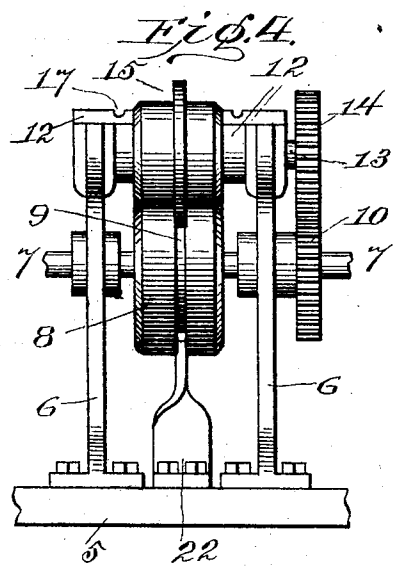
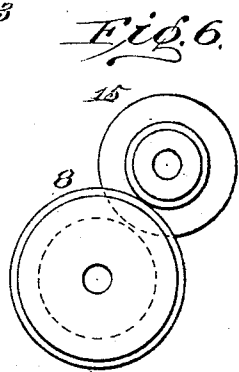
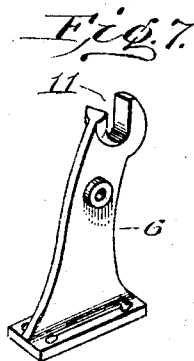
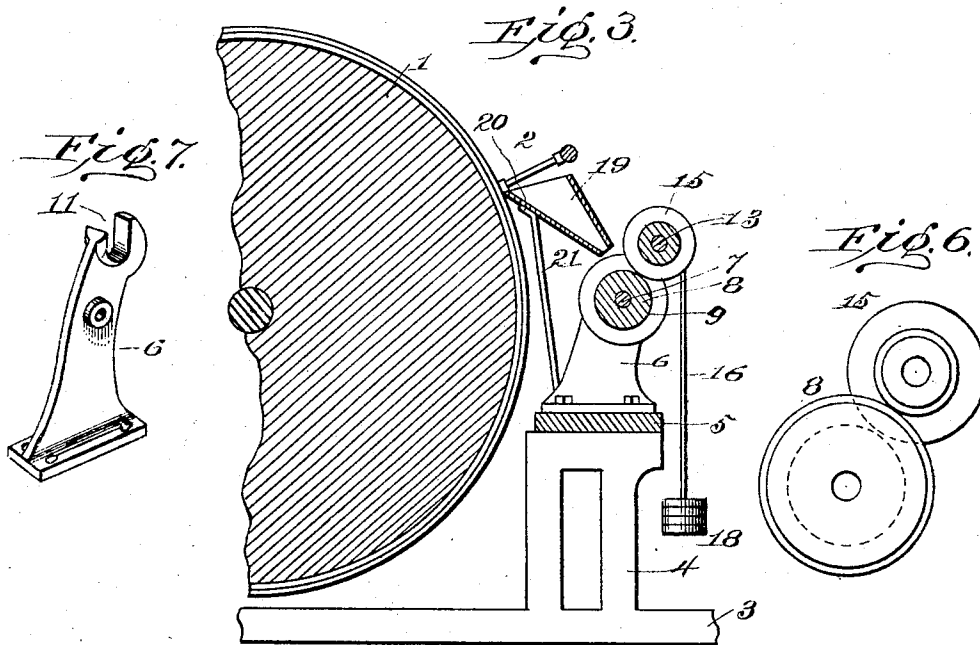

Witnesses  
L. E. Money  
W. F. Crossman

Inventor  
John Florence  
By  
C. J. Bell  
Attorney

# UNITED STATES PATENT OFFICE.

JOHN FLORENCE, OF CHARLOTTE, NORTH CAROLINA, ASSIGNOR OF ONE-HALF TO JNO. B. ROSS & CO., OF CHARLOTTE, NORTH CAROLINA.

## SLIVER-CONDENSER FOR CARDING-MACHINES.

No. 796,837.

Specification of Letters Patent.

Patented Aug. 8, 1905.

Application filed February 2, 1905. Serial No. 243,877

*To all whom it may concern:*

Be it known that I, JOHN FLORENCE, a citizen of the United States, residing at Charlotte, in the county of Mecklenburg and State of North Carolina, have invented certain new and useful Improvements in Sliver-Condensers for Carding-Machines, of which the following is a specification.

This invention relates to carding-machines, and pertains especially to an attachment for such machines as are capable of working or carding jute.

The object of the invention is to provide carding-machines with novel and peculiar means for receiving the material from the doffer and for compressing, finishing, and shaping such material into strips, strands, or rovings.

A further object of the invention is to provide means of attachment to the ordinary carding-machine whereby such machines are made specially adaptable for taking jute or similar material directly from a doffer for compressing, shaping, and finishing the same into separate strings, strips, or rovings without further treatment to effect this result.

A still further object of the invention is to provide a series of grooved rollers, a series of rotary disks working in the grooves, and loose journal-bearings for the disks whereby the latter are given a variable bearing with respect to the rollers and effect a uniform compression of the material between the disks and the bottom of the grooves.

A still further object of the invention is to provide, in a carding-machine, pairs of independent brackets in which a shaft is journaled having a series of grooved rollers secured thereto, a pair of loose bearings carried by each pair of brackets, a series of shafts independently journaled in said bearings, and a series of chutes to convey the carded material into the said grooves for shaping and finishing it into strips or rovings.

It has been found that in the treatment of jute, and particularly to utilize worn-out or partly-worn jute articles—such as sacks, bags, and wrappings—the usual mechanism for receiving the jute from the doffer of the first carding-machine and carrying it to the finisher the latter and said mechanism may all be dispensed with and the desired results attained by the application of the mechanism herein-

before referred to and which will be hereinafter described in detail.

With these and various other objects, advantages, and improved results in view the invention consists in the novel construction and arrangement of parts, and particularly in combining with an ordinary carding-machine a series of rotary disks having variable bearings with respect to a series of grooved rollers for compressing, shaping, and finishing jute or like material into strands or strips.

Difficulty has been experienced in forming strands, strips, or rovings of jute and like material in machines of this character owing to the absence of means for compressing and forming the material into continuous separate strands or ropes without having the compressor and former choke for want of facilities to permit foreign matter contained in the strands to pass through the compressor.

It is therefore the purpose of this invention to obviate such difficulty and to overcome various other disadvantages found in such machines.

In the accompanying drawings, forming part of this application, Figure 1 is a side view of a carding-machine frame and doffer, partly broken away, showing the application of the invention. Fig. 2 is a front elevation, partly broken away. Fig. 3 is a sectional view on the line *xx*, Fig. 2. Fig. 4 is a detail front elevation of a pair of brackets carrying a disk, a roller, and gear. Fig. 5 is a top view of the mechanism shown in Fig. 4. Fig. 6 is a detail end view of a disk and a roller. Fig. 7 is a perspective view of one of the brackets. Fig. 8 is a detail side elevation of a pair of loose bearings carrying a disk and its shaft. Fig. 9 is a perspective view of one of the loose bearings.

The same numeral-references denote the same parts throughout the several views of the drawings.

The doffer 1 is driven in the usual or any suitable manner, being provided with an ordinary comb 2, and the frame 3 has uprights 4, to which is secured a base 5, supporting a series of journal-brackets 6, secured thereto in pairs. A shaft 7 extends through all the hangers, having motion imparted to it by suitable means, and on said shaft within each pair of hangers is a roller 8, having an annular groove 9, and on one side of each pair of

hangers is a gear 10, secured to the shaft 7. The top of the brackets have a U-shaped opening 11, in which is fitted loose bearing-blocks 12 for a series of shafts 13, revolved in said blocks between each pair of brackets by a pinion 14 on each shaft 13 meshing with the gears 10. Secured to each of the shafts 13 between the blocks 12 is a rotary disk 15, working in the roller-grooves 9, whereby the bearing-blocks are held against longitudinal movement. In order to permit vertical movement of the blocks 12 and a flexible action of the disks in the grooves, a rod 16 is hung from a notch 17 in the blocks and carries such weights 18 as may be found necessary for the proper operation of the disks.

A series of chutes 19 (one for each roller) incline from the doffer under the comb, whence they carry the material into the roller-grooves 9. These chutes are suspended by a bar 20, which is supported by arms 21 from the frame-base. Each roller has a guard 22 projecting into the roller-grooves to prevent the material under treatment from encircling the groove and to keep the latter clean. It is obvious that the chutes separate and carry the jute or similar material into the roller-grooves and under the disks, where it is compressed, shaped, and finished in its passage between the grooves and disks into uniform strands, strips, or rovings, and that the vertical movement of the disks independent one of the other will permit the passage of such foreign matter incapable of being compressed by the disks and rollers as may occur in the strands or strips without choking the grooves, breaking the strips, or stopping the revolution of the disks and rollers.

It will be seen that owing to the independence of the rollers, and particularly of the disks, each of the latter has an independent relation to the rollers, so that either may be adjusted longitudinally, and in operation one or more disks may move vertically without such movement being imparted to the remaining disks.

Having thus described my invention, what I claim as new, and desire to secure by Letters Patent, is—

1. An attachment for carding-machines comprising a single shaft of grooved rollers in alinement, independent disk-shafts, and rotary disks working in the grooves to compress, shape and finish the discharge from the machine into a series of separate strips or rovings.

2. The combination, with a doffer, of a series of grooved rollers positioned relative to the doffer to have the latter discharge into the grooves, and a series of rotary disks journaled to have a variable bearing with respect to the

rollers and working in the grooves to compress, shape and finish such discharge into a series of strips or rovings.

3. In a carding-machine, the combination of a device for compressing, shaping and finishing, comprising grooved rollers, a series of rotary disks working in the grooves, and means for connecting the disks and rollers to permit passage therebetween of the discharge in various size from the machine into separate strips or rovings of equal size.

4. The combination, with the grooved rollers having stationary journal-bearings, and the rotary disks working in the grooves, of means for loosely connecting the disks with the rollers comprising movable journal-bearings for the disks, and weights to govern the action of the movable bearings.

5. The combination, with the grooved rollers having stationary journal-bearings, and the rotary disks working in the grooves, of the movable journal-bearings for the disks, and means to control the action of the movable bearings.

6. The combination, with the grooved rollers having stationary journal-bearings, and the rotary disks, of the loose disk-bearings held against longitudinal movement by the disks working in the grooves, and means to control the vertical movement of the disk-bearings.

7. The combination, with the grooved rollers mounted on a single shaft, and the rotary disks each having a separate shaft in alinement one with the other, of a pair of brackets for each disk, and a pair of vertically-movable journal-bearings carried by the brackets and held against longitudinal movement by the disks working in the grooves.

8. The combination, with a doffer, the grooved rollers, and the disks working in the grooves, of a chute for each disk inclined from the doffer to carry material into the grooves, substantially as and for the purpose set forth.

9. The combination, with a carding-machine having a suitable doffer, of a series of chutes distributed throughout the length of the doffer and receiving therefrom, a series of independent rotary disks hung in front of the chutes, a series of independent rollers having a groove receiving from the chutes and in which grooves the disks work, a pinion for each disk, a gear for each roller to mesh with the pinions to impart motion to the disks, a roller-shaft, and means to drive the shaft.

In witness whereof I hereunto set my hand in the presence of two witnesses.

JOHN FLORENCE

Witnesses:

THOS. H. ROSS,  
W. M. MOORE.