



US00D701853S

(12) **United States Design Patent**  
**Wilson**

(10) **Patent No.:** **US D701,853 S**

(45) **Date of Patent:** **\*\* Apr. 1, 2014**

(54) **HANDLE FOR A SPEAKER**

(75) Inventor: **George Wilson**, Newlands (GB)

(73) Assignee: **Tannoy Limited** (GB)

(\*\*) Term: **14 Years**

(21) Appl. No.: **29/397,891**

(22) Filed: **Jul. 22, 2011**

(30) **Foreign Application Priority Data**

Jan. 31, 2011 (GB) ..... 4018602

(51) **LOC (10) Cl.** ..... **14-03**

(52) **U.S. Cl.**

USPC ..... **D14/214**; D14/221

(58) **Field of Classification Search**

USPC ..... D14/168, 172, 185, 188, 196, 204–216,  
D14/221, 222; 381/300–303, 306, 332, 333,  
381/336, 345, 361–364, 386–388; 181/143,  
181/144, 147, 148, 150, 153, 157, 198, 199

See application file for complete search history.

(56) **References Cited**

**U.S. PATENT DOCUMENTS**

D468,287 S *	1/2003	Cornelissen	.....	D14/185
D587,239 S *	2/2009	Raisanen et al.	.....	D14/188
D637,580 S *	5/2011	Aranda et al.	.....	D14/214
D638,400 S *	5/2011	Hawkins et al.	.....	D14/214
D654,474 S *	2/2012	Hawkins et al.	.....	D14/214
D682,255 S *	5/2013	Lum et al.	.....	D14/221

\* cited by examiner

*Primary Examiner* — Keli L. Hill

(74) *Attorney, Agent, or Firm* — Lerner, David, Littenberg,  
Krumholz & Mentlik, LLP

(57) **CLAIM**

The ornamental design for handle for a speaker, as shown and described.

**DESCRIPTION**

FIG. 1 is a front perspective view of one embodiment of a handle for a speaker, in accordance with the present invention;

FIG. 2 is a back perspective view of the handle for a speaker shown in FIG. 1;

FIG. 3 is a plan view from above of the handle for a speaker shown in FIG. 1;

FIG. 4 is a front elevation view of the handle for a speaker shown in FIG. 1;

FIG. 5 is a front perspective view of the handle for a speaker shown in FIG. 1 displaying a cross-sectional plane labeled “FIG. 6”; and,

FIG. 6 is a partial cross-sectional view of the handle for a speaker shown in FIG. 5, based on the plane labeled “FIG. 6” in FIG. 5.

The broken lines within the claim area represent stitching. The dot-dot-dash broken lines seen along the bottom of the claimed design in FIGS. 1, 2, 4 and 5 represent the bounds of the claimed design, while the broken line showing of the six small screw heads on top of the speaker in FIGS. 1-3 and 5 are included for the purpose of illustrating portions of the handle for a speaker; all of the broken lines form no part of the claimed design.

**1 Claim, 6 Drawing Sheets**

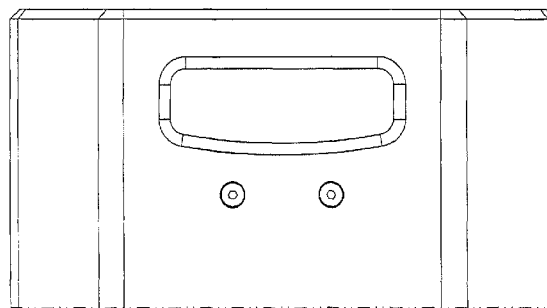
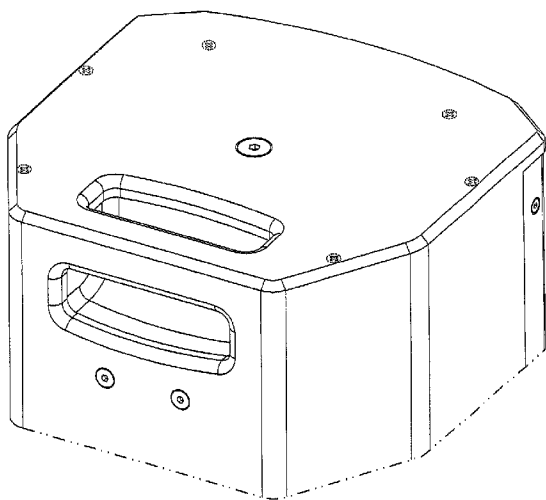

Fig. 1

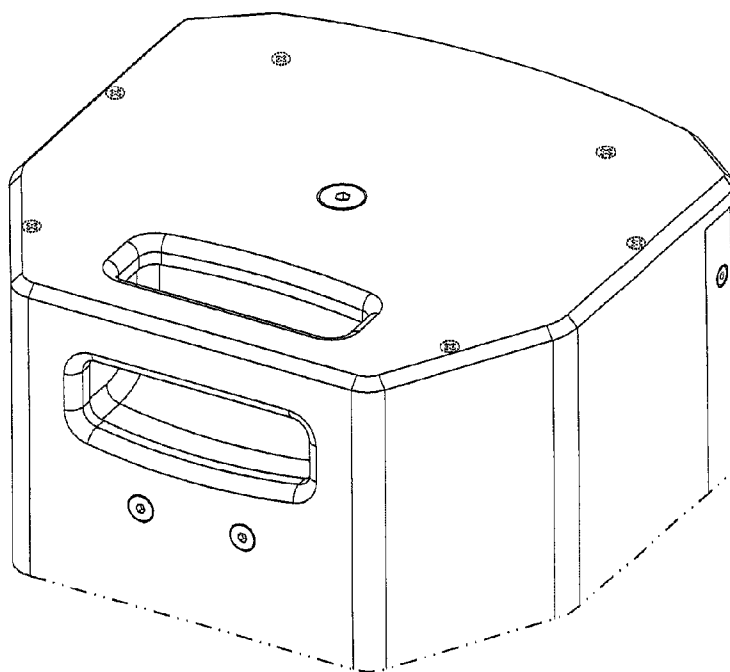
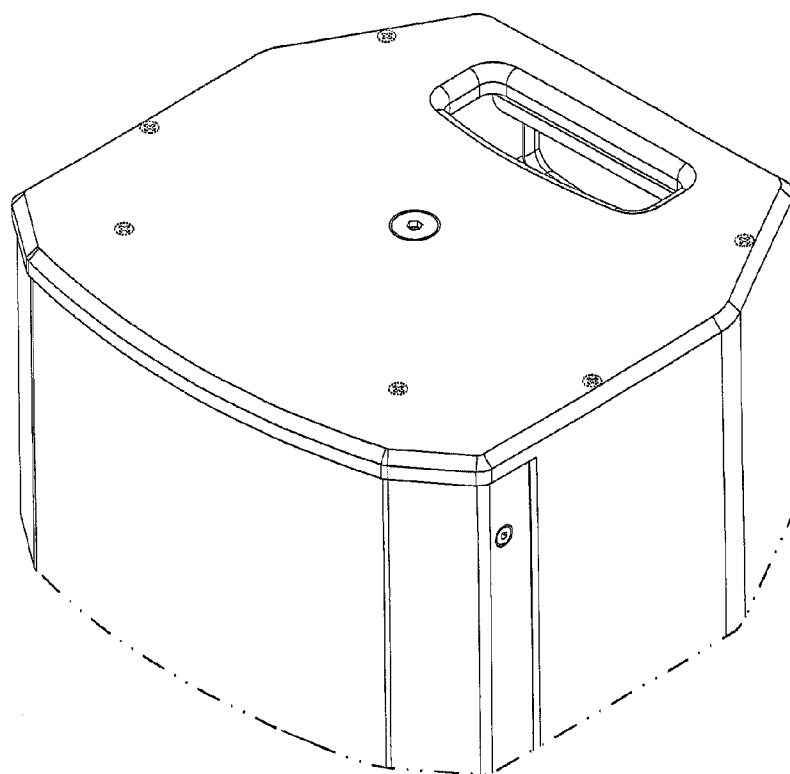

Fig. 2



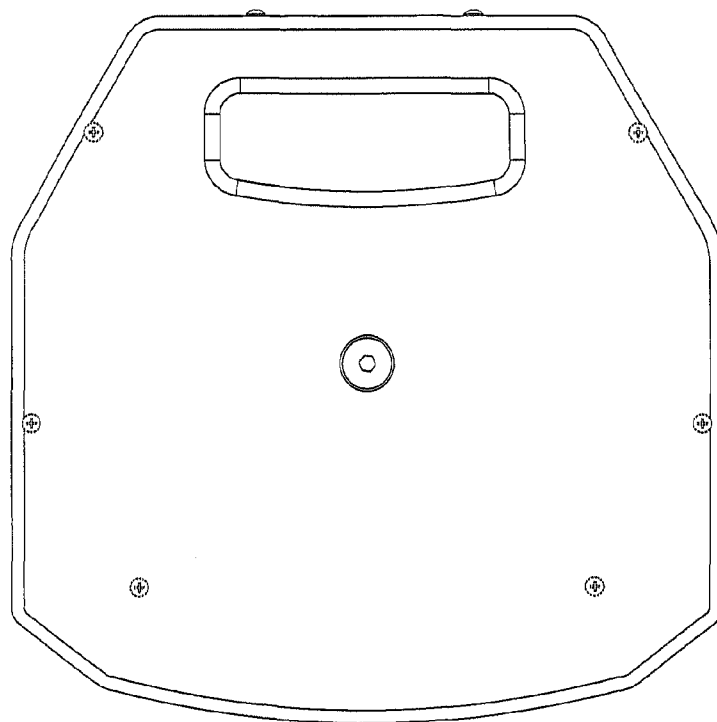

Fig. 3

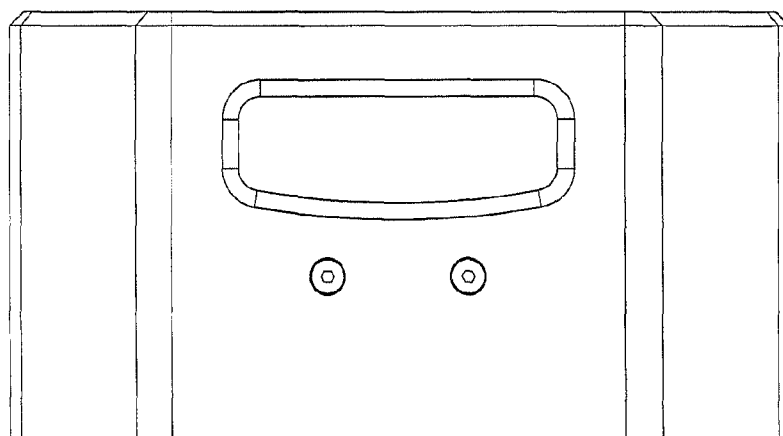

Fig. 4

Fig. 5

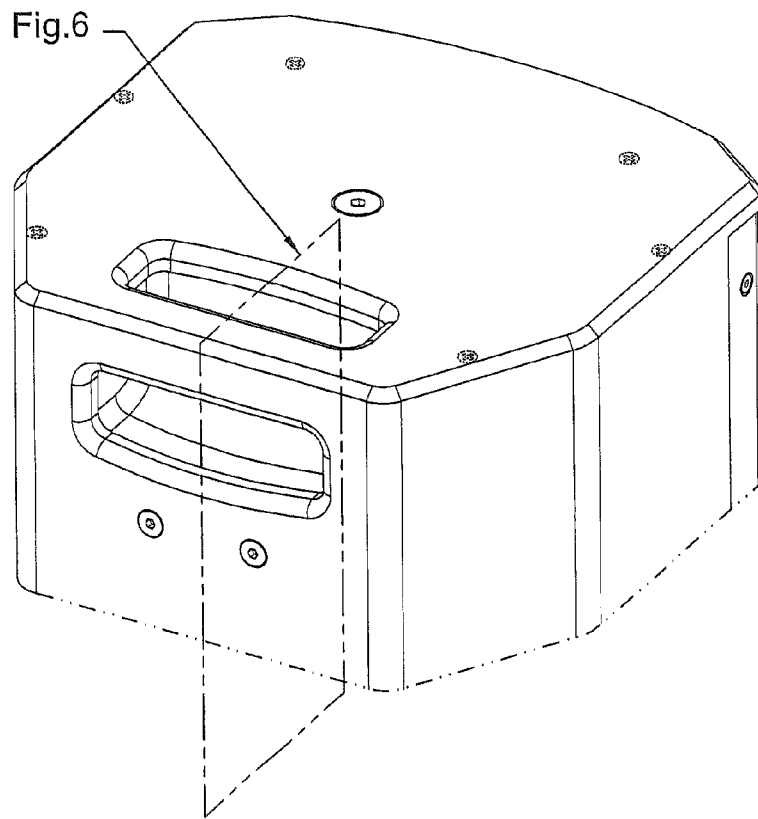

Fig. 6

