

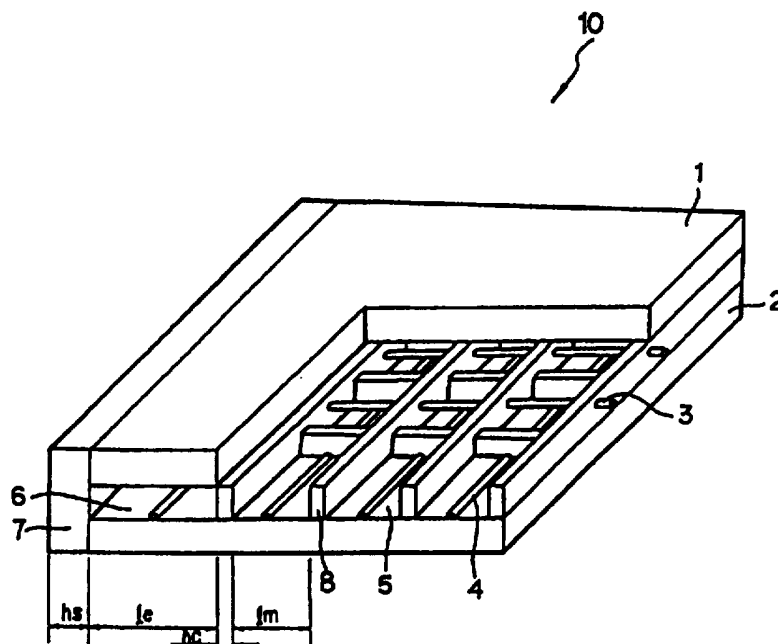

INTERNATIONAL APPLICATION PUBLISHED UNDER THE PATENT COOPERATION TREATY (PCT)

<p>(51) International Patent Classification ⁶ : G09F 9/313</p>	<p>A1</p>	<p>(11) International Publication Number: WO 96/14631 (43) International Publication Date: 17 May 1996 (17.05.96)</p>
<p>(21) International Application Number: PCT/KR94/00155 (22) International Filing Date: 4 November 1994 (04.11.94)</p> <p>(71) Applicants (for all designated States except US): ORION ELECTRIC CO., LTD. [KR/KR]; 165, Gongdan-dong, Gumi-shi, Kyung-sangbuk-do 730-030 (KR). SPC PLASMA CO. [RU/RU]; ul. Tsiolkovsky, 24, Ryazan, 390023 (RU).</p> <p>(72) Inventors; and (75) Inventors/Applicants (for US only): LEE, Chun, Woo [KR/KR]; Ah-206, Kangbyun Apartment, 28, Bisan-dong, Gumi-shi, Kyung-sangbuk-do 730-100 (KR). KWON, Hyuk, Chae [KR/KR]; 674-3, Manchon-1 dong, Susung-gu, Daegu 706-021 (KR). SAMORODOV, Vladislav Georguevich [RU/RU]; ul. Urizcogo, 18-17, Ryazan, 390023 (RU). POKRYVAILO, Anatoli Borisovich [RU/RU]; ul. Scmoroshinca, 15-2-44, Ryazan, 390006 (RU). NIKO-LAEBICH, Zhuralev Stanislav [RU/RU]; ul. Shedrina, 8a-6, Ryazan, 390006 (RU). MIHAILOVICH, Sokolov Vladimir [RU/RU]; ul. Timurovtsev, 11-1-27, Ryazan, 390037 (RU). GRUGOREBNA, Starynina Tachyana [RU/RU]; ul. Zubkova, 27-166, Ryazan, 390048 (RU).</p> <p>(74) Common Representative: ORION ELECTRIC CO., LTD.; 165, Gongdan-dong, Gumi-shi, Kyung-sangbuk-do 730-030 (KR).</p>		<p>(81) Designated States: JP, US, European patent (AT, BE, CH, DE, DK, ES, FR, GB, GR, IE, IT, LU, MC, NL, PT, SE).</p> <p>Published With international search report.</p>

(54) Title: PLASMA DISPLAY PANEL FOR MULTI-SCREEN SYSTEM



(57) Abstract

This invention discloses a plasma display panel for multi-screen system. The plasma display panel (10) comprises the upper dielectric plate (1) and the lower dielectric plate (2). Cathode electrode (3) and anode electrode (4) are orthogonally located between said plates (1 and 2). These electrodes (3 and 4) form display cell (5 and 6), the cell (5) being formed between barrier ribs (8) and the cell (6) being adjacent to one side of sealing seam (7). The display cells (5 and 6) are separated by barrier ribs (8). The display cell (6) adjacent to the sealing seam are made of a size increasing in direction perpendicular to the sealing seam (7) with respect to the rest of the display cell (5).

FOR THE PURPOSES OF INFORMATION ONLY

Codes used to identify States party to the PCT on the front pages of pamphlets publishing international applications under the PCT.

AT	Austria	GB	United Kingdom	MR	Mauritania
AU	Australia	GE	Georgia	MW	Malawi
BB	Barbados	GN	Guinea	NE	Niger
BE	Belgium	GR	Greece	NL	Netherlands
BF	Burkina Faso	HU	Hungary	NO	Norway
BG	Bulgaria	IE	Ireland	NZ	New Zealand
BJ	Benin	IT	Italy	PL	Poland
BR	Brazil	JP	Japan	PT	Portugal
BY	Belarus	KE	Kenya	RO	Romania
CA	Canada	KG	Kyrgystan	RU	Russian Federation
CF	Central African Republic	KP	Democratic People's Republic of Korea	SD	Sudan
CG	Congo	KR	Republic of Korea	SE	Sweden
CH	Switzerland	KZ	Kazakhstan	SI	Slovenia
CI	Côte d'Ivoire	LI	Liechtenstein	SK	Slovakia
CM	Cameroon	LK	Sri Lanka	SN	Senegal
CN	China	LU	Luxembourg	TD	Chad
CS	Czechoslovakia	LV	Latvia	TG	Togo
CZ	Czech Republic	MC	Monaco	TJ	Tajikistan
DE	Germany	MD	Republic of Moldova	TT	Trinidad and Tobago
DK	Denmark	MG	Madagascar	UA	Ukraine
ES	Spain	ML	Mali	US	United States of America
FI	Finland	MN	Mongolia	UZ	Uzbekistan
FR	France			VN	Viet Nam
GA	Gabon				

PLASMA DISPLAY PANEL FOR MULTI-SCREEN SYSTEM

TECHNICAL FIELD

5 The present invention relates to a structure of a plasma display panel and more particularly, to a structure of a plasma display panel for multi-screen system in which the display cells adjacent to the sealing seam of the panel are made of a size increasing in direction perpendicular to the sealing seam with respect to the rest of the display cells thereby reducing a distortion of information displayed on the screen.

BACKGROUND ART

15 The most similar prior art in technical essence to this invention is the plasma display panel disclosed in USSR Patent No. 1074301 (March 30, 1982). This plasma display panel comprises upper and lower plates and systems of mutually orthogonal electrodes, in which display cells adjacent to the sealing seam are formed by hollows or grooves, and an external sealing element is separated from internal cell volume by a light-translucent element with a round cross-section inserted into the hollow and located around the edges.

20 However, the drawbacks of the USSR patent is in loss of a pitch at the place of joint of panels because of large thickness of the sealing seam and it results in information distortion displayed on the screen.

DISCLOSURE OF THE INVENTION

30 Accordingly, in consideration of the drawbacks of said described patent, the main object of the present invention is to provide improvement of information quality displayed in the at the expense of elimination of information distortion at the place of panel sealing parts.

35

To accomplish the object, the present invention comprises upper and lower dielectric plates, cathode and anode electrodes orthogonally located between said plates, display

cells defined by said electrodes, barrier ribs for separating and defining display cells from each other and sealing seam for sealing edge parts of said two plates, in which the display cells adjacent to the sealing seam are made
 5 of a size increasing in direction perpendicular to the sealing seam with respect to the rest of the display cells.

BRIEF DESCRIPTION OF DRAWINGS

10 Fig. 1 is a schematic view depicting the plasma display panel for PDP multi-screen system.

DETAILED DESCRIPTION OF THE INVENTION

In Fig. 1, PDP (10) comprises the upper dielectric
 15 plate(1) and the lower dielectric plate (2). Cathode electrode(3) and anode electrode(4) are orthogonally located between said plates (1) and (2). These electrodes (3) and (4) form display cell (5) and (6), the cell (5) being formed between barrier ribs (8) and the cell (6) being adjacent to
 20 one side of sealing seam (7). The display cells (5) and (6) are separated by barrier ribs (8).

As depicted, the horizontal length of display cell (6) adjacent to sealing seam (7) is more long than the horizontal
 25 length of display cell (5) being formed between barrier ribs (8) and that the following ratio should be observed :

$$0.5 (h_s - h_c) + l_m \leq l_e \leq (h_s - h_c) + l_m$$

30 l_e : size of cell (6) adjacent to the sealing seam (7);
 l_m : size of cell (5)
 h_s : width of sealing seam (7);
 h_c : width of barrier rib (8) between cells (5);

35 For example, if size of cell(5) is 1.2 x 2 mm, width of sealing seam (7) is 1.5 mm and width of barrier ribs (8) between cells (5) is 1.5 mm, size of cell (6) adjacent to the sealing seam (7) becomes 2.7mm.

Increasing of size of cell (6) adjacent to the sealing seam (7) within the limits of given ratio results in keeping of specific light flux constant in the centre of panels and the place of their joints and it assists to create more favourable conditions for an operator to read the screen information.

When making size of cells (6) adjacent to the sealing seam (7) $l_e \geq (h_s - h_c) + l_m$, an intensified light occurs in the region of the sealing seam being provoked by light flux increase of more than 30 % and resulting in information perception with distortion.

When making size of cells (6) adjacent to the sealing seam (7) $l_e \leq (h_s - h_c) + l_m$, a loss of information takes place as a result of light flux reduction coming from cell adjacent to the sealing by more than 30%.

$\pm 30\%$ is permissible limit of screen non-uniform light for DC-type plasma display panels required for normal perception of information on the screen.

As above mentioned, this invention allows to eliminate video-information distortion in multi-screen system in places of panel joints and it results in quality improvement of information displayed.

CLAIMS:

1. A plasma display panel for multi-screen system comprising:
5 upper and lower dielectric plates;
cathode and anode electrodes orthogonally located between said plates;
display cells defined by said electrodes;
10 barrier ribs for separating and defining display cells from each other; and
sealing seam for sealing edge parts of said two plates, wherein the display cells adjacent to the sealing seam are made of a size increasing in direction perpendicular to the sealing
15 seam with respect to the rest of the display cells.

2. A plasma display panel according to claim 1 wherein a size ratio between display cells adjacent to the sealing seam and the rest of the display cells is expressed by the following
20 equation:

$$0.5 (h_s - h_c) + l_m \leq l_e \leq (h_s - h_c) + l_m$$

l_e : size of cell adjacent to the sealing seam;

l_m : size of cell;

h_s : width of sealing seam ;

- 25 h_c : width of barrier rib between cells ;

1/1

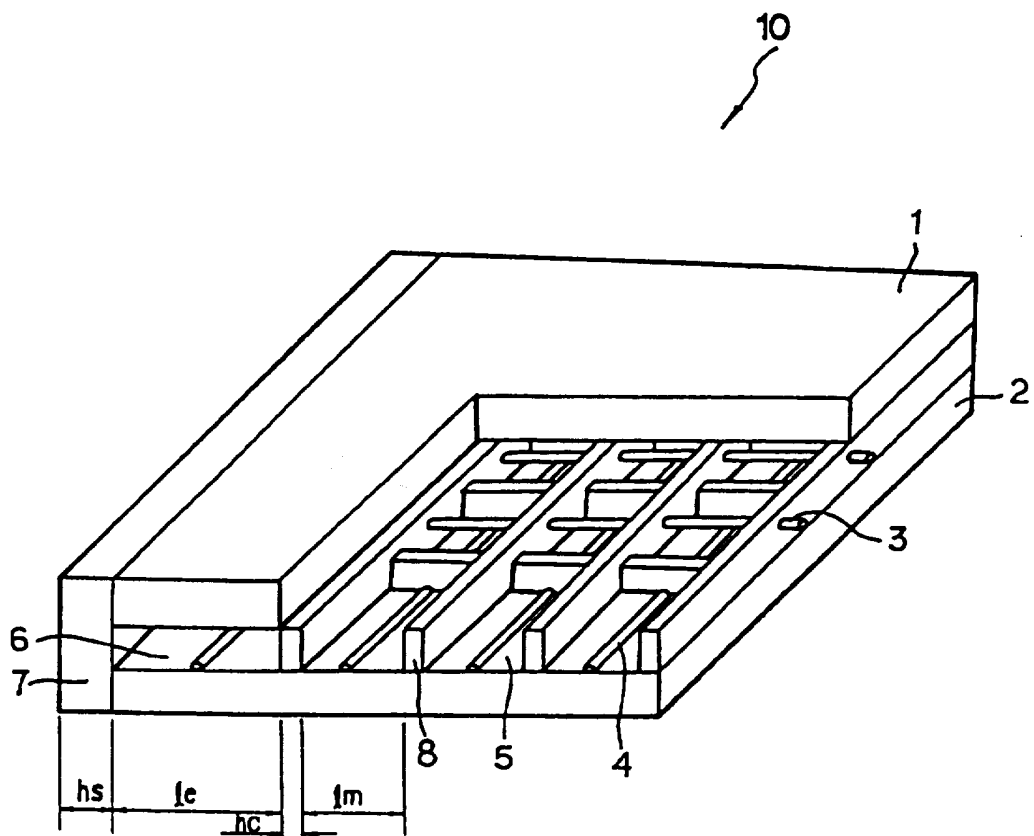

FIG. 1

INTERNATIONAL SEARCH REPORT

International application No.

PCT/KR 94/00155

A. CLASSIFICATION OF SUBJECT MATTER

IPC⁶: G 09 F 9/313

According to International Patent Classification (IPC) or to both national classification and IPC

B. FIELDS SEARCHED

Minimum documentation searched (classification system followed by classification symbols)

IPC⁶: G 09 F 9/313, 9/00; H 01 J 17/49, 17/34, 17/00

Documentation searched other than minimum documentation to the extent that such documents are included in the fields searched

Electronic data base consulted during the international search (name of data base and, where practicable, search terms used)

WPIL

C. DOCUMENTS CONSIDERED TO BE RELEVANT

Category*	Citation of document, with indication, where appropriate, of the relevant passages	Relevant to claim No.
X	FR 26 96 867 A (MITSUBISHI) 15 April 1994 (15.04.94) fig. 1,12,16-20; page 32, line 15 - page 33, line 11; claims 1,2.	1
A	fig. 1,12,16-20; page 32, line 15 - page 33, line 11; claims 1,2.	2
X	Soviet Inventions Illustrated, section EL, week 8826, Derwent Publications Ltd., London, S25, SU 1074301 (BALAKIN) fig.; abstract;	1
A	fig.; abstract.	2
A	US 5099 173 A (KIM) 24 March 1994 (24.03.94), fig. 2-5; column 3, line 11 - column 4, line 51; claim.	1,2
A	US 4 562 434 (AMANO) 31 December 1985 (31.12.85) fig. 4,5,16,17; column 2, line 50 - column 3, line 14; column 7, lines 12-24; claims.	1,2

Further documents are listed in the continuation of Box C.

See patent family annex.

- * Special categories of cited documents:
- "A" document defining the general state of the art which is not considered to be of particular relevance
- "E" earlier document but published on or after the international filing date
- "L" document which may throw doubts on priority claim(s) or which is cited to establish the publication date of another citation or other special reason (as specified)
- "O" document referring to an oral disclosure, use, exhibition or other means
- "P" document published prior to the international filing date but later than the priority date claimed
- "T" later document published after the international filing date or priority date and not in conflict with the application but cited to understand the principle or theory underlying the invention
- "X" document of particular relevance; the claimed invention cannot be considered novel or cannot be considered to involve an inventive step when the document is taken alone
- "Y" document of particular relevance; the claimed invention cannot be considered to involve an inventive step when the document is combined with one or more other such documents, such combination being obvious to a person skilled in the art
- "&" document member of the same patent family

Date of the actual completion of the international search
30 June 1995 (30.06.95)

Date of mailing of the international search report
19 July 1995 (19.07.95)

Name and mailing address of the ISA/ AT
AUSTRIAN PATENT OFFICE
Kohlmarkt 8-10
A-1014 Vienna
Facsimile No. 1/53424/535

Authorized officer
Wenninger e.h.
Telephone No. 1/53424/320

INTERNATIONAL SEARCH REPORT
Information on patent family members

International application No.

PCT/KR 94/00155

In Recherchenbericht angeführtes Patentedokument Patent document cited in search report Document de brevet cité dans le rapport de recherche	Datum der Veröffentlichung Publication date Date de publication	Mitglied(er) der Patentfamilie Patent family member(s) Membre(s) de la famille de brevets	Datum der Veröffentlichung Publication date Date de publication
FR A 2696867		FR A1 2690273 FR A1 2696867 FR E1 2690273 US A 405494 US A 4288263 JP A2 500994 JP A2 525797	22-10-93 15-04-94 09-06-93 11-04-93 27-06-93 28-09-93 10-12-93
US A 5099173	24-03-92	FR A1 2657713 FR E1 2657713 JP A2 4226941 JP E4 7048352 KR E1 92202527 FR A1 2657713 FR E1 2657713 JP A2 3283233 JP E4 6001671 KR E1 9202525 US A 5124615 KR E1 9202526	02-08-91 01-10-93 07-10-91 24-05-91 27-03-91 02-08-91 21-04-93 13-12-91 05-01-94 27-03-92 23-06-92 27-03-92
US A 4562434	31-12-85	CA A1 1205227 DE A1 3330212 DE C2 3330212 FR A1 2511530 FR E1 2511530 FR A1 1051022 GB E2 2105102 JP A2 5003038 JP E4 4050478 KR E1 9008791	27-05-86 03-03-86 13-02-92 18-02-92 01-04-86 16-03-86 26-02-86 22-02-86 01-09-91 29-11-90