

(19) World Intellectual Property
Organization
International Bureau



(43) International Publication Date
25 November 2004 (25.11.2004)

PCT

(10) International Publication Number
WO 2004/102005 A1

(51) International Patent Classification⁷: F04C 29/02, 23/00

(21) International Application Number: PCT/JP2004/007133

(22) International Filing Date: 19 May 2004 (19.05.2004)

(25) Filing Language: English

(26) Publication Language: English

(30) Priority Data:
2003-139770 19 May 2003 (19.05.2003) JP
2003-139771 19 May 2003 (19.05.2003) JP
2003-139772 19 May 2003 (19.05.2003) JP

(71) Applicant (for all designated States except US): MAT-SUSHITA ELECTRIC INDUSTRIAL CO., LTD. [JP/JP]; 1006, Oaza Kadoma, Kadoma-shi, Osaka 571-8501 (JP).

(72) Inventors; and

(75) Inventors/Applicants (for US only): HASEGAWA, Hiroshi. OKAICHI, Atsuo. NISHIWAKI, Fumitoshi.

(74) Agents: SHIMIZU, Yoshihiro et al.; 3rd Floor, Yashiro Building, 14-4, Takadanobaba 2-chome, Shinjuku-ku, Tokyo 169-0075 (JP).

(81) Designated States (unless otherwise indicated, for every kind of national protection available): AE, AG, AL, AM, AT, AU, AZ, BA, BB, BG, BR, BW, BY, BZ, CA, CH, CN, CO, CR, CU, CZ, DE, DK, DM, DZ, EC, EE, EG, ES, FI, GB, GD, GE, GH, GM, HR, HU, ID, IL, IN, IS, KE, KG, KP, KR, KZ, LC, LK, LR, LS, LT, LU, LV, MA, MD, MG, MK, MN, MW, MX, MZ, NA, NI, NO, NZ, OM, PG, PH, PL, PT, RO, RU, SC, SD, SE, SG, SK, SL, SY, TJ, TM, TN, TR, TT, TZ, UA, UG, US, UZ, VC, VN, YU, ZA, ZM, ZW.

(84) Designated States (unless otherwise indicated, for every kind of regional protection available): ARIPO (BW, GH, GM, KE, LS, MW, MZ, NA, SD, SL, SZ, TZ, UG, ZM, ZW), Eurasian (AM, AZ, BY, KG, KZ, MD, RU, TJ, TM), European (AT, BE, BG, CH, CY, CZ, DE, DK, EE, ES, FI, FR, GB, GR, HU, IE, IT, LU, MC, NL, PL, PT, RO, SE, SI, SK, TR), OAPI (BF, BJ, CF, CG, CI, CM, GA, GN, GQ, GW, ML, MR, NE, SN, TD, TG).

Published:
— with international search report

For two-letter codes and other abbreviations, refer to the "Guidance Notes on Codes and Abbreviations" appearing at the beginning of each regular issue of the PCT Gazette.

(54) Title: COMPRESSOR

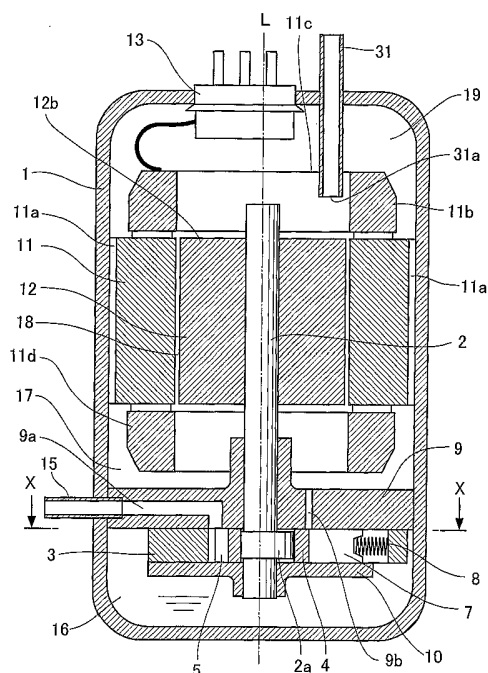

(57) Abstract: A compressor comprising a hermetic container, a compression mechanism disposed in a lower portion in the hermetic container, a rotational motor disposed in an upper portion in the hermetic container and having a stator and a rotor, coil ends provided on upper end lower ends of the stator, a discharge pipe provided on an upper end of the hermetic container, and an oil reservoir provided in a lower portion in the hermetic container, in which working fluid compressed by the compression mechanism is introduced into an upper space of the hermetic container from a gap between the rotational motor and the hermetic container, and the working fluid is discharged out from the hermetic container through the discharge pipe, wherein an open end in the hermetic container of the discharge pipe is located inside the upper end coil end.

WO 2004/102005 A1

DESCRIPTION**COMPRESSOR****Technical Field**

The present invention relates to a compressor used for a refrigerator-freezer, an air conditioner and the like.

Background Technique

A hermetical type rotary compressor is widely used for a refrigerator-freezer, an air conditioners and the like because it is small in size and its structure is simple. A structure of the hermetical type rotary compressor such as a rotary compressor and a scroll compressor is described in a non-patent document 1. The structure of the hermetical type rotary compressor will be explained with reference to Figs. 19 and 20 based on a rotary compressor (compressor, hereinafter). Fig. 19 is a vertical sectional view of a conventional compressor.

The compressor shown in the drawings comprises a hermetical container 1, a shaft 2 having an eccentric portion 2a, a cylinder 3, a roller 4, a vane 7, a spring 8, an upper bearing 9 and a lower bearing 10. The compressor also comprises a compression mechanism disposed in a lower portion of the hermetical container 1, and a rotational motor having a stator 11 and a rotor 12. The stator 11 is provided at its upper end lower ends with coil ends 11b and 11d. The rotational motor is disposed above the hermetical container 1.

A plurality of notches 11a are formed in an outer periphery of the stator 11. The notches 11a serve as flow paths for working fluid.

The hermetical container 1 is provided at its upper portion with an introducing terminal 13 which energizes a rotational motor in the hermetical container 1, and a discharge pipe 14 for introducing working fluid from the hermetical container 1 into a refrigeration cycle. The discharge pipe 14 is in communication with inside the hermetical container 1. The discharge pipe 14 is located above the upper coil end 11b of the stator 11 so that a suction port 14a of the discharge pipe 14 does not come into contact with the stator 11 and the rotor 12 of the rotational motor. The hermetical container 1 is provided at its side surface with a suction pipe 15 for introducing working fluid from the refrigeration cycle into the compressor. Refrigeration oil is reserved in an oil reservoir 16 formed in a bottom of the hermetical container 1. A cluster 26 is mounted on the introducing terminal 13, a lead wire 25 from the stator 11 of the rotational motor is connected to the cluster 26 so that current is supplied to the rotational motor from the introducing terminal 13.

The operation of the compressor will be explained. If the rotational motor of the compressor is energized to rotate the rotor 12, the roller 4 rotates eccentrically by the eccentric portion 2a, and capacities of the compressor (not shown) and a suction chamber 5 formed in the cylinder 3 are varied. With this eccentric rotation, the working fluid is drawn into the suction chamber 5, and compressed in a compression chamber. The compressed working fluid is mixed with fog drip (oil mist, hereinafter) of refrigeration oil which is supplied from the oil reservoir 16 and lubricates the compression mechanism. This mixture is discharged into a lower space 17 of the rotational motor through the discharging hole 9b, and passes through the notches 11a of the stator 11 and a gap 18 between the stator 11 and the rotor 12, and flows into an upper space 19 of the rotational motor.

The working fluid is discharged out from the discharge pipe 14, but the refrigeration oil mixed with the working fluid is also discharged at the same time. Therefore, in the conventional compressor, in order to enhance the reliability of the compressor and the efficiency of the refrigeration cycle, the oil is separated from the working fluid to prevent the refrigeration oil from being discharged out from the hermetical container 1.

To separate the refrigeration oil from the working fluid, there is a method to use an oil-separating plate provided on an upper portion of the rotor 12 as disclosed in a patent document 1. Fig. 21 is a detailed sectional view of peripheries of the oil-separating plate. The rotor 12 includes an upper end plate 21a and a lower end plate 21b for closing an insertion hole of a permanent magnet 20. A plurality of through holes 12a formed in the rotor 12 in the vertical direction and an oil-separating plate 23 disposed above exits of the through holes 12a are fixed to the rotor 12 by a fixing member 24. The oil-separating plate 23 forms an oil-separating space 22 between an upper surface of the rotor 12 and the oil-separating plate 23.

In the compressor having such a structure, a portion of working fluid including oil mist discharged from the compression mechanism into the lower space 17 of the rotational motor flows into the oil-separating space 22 through the through holes 12a. The working fluid is radially discharged from an outer peripheral exit of the oil-separating plate 23 by a centrifugal force, and the working fluid is sprayed on the coil end 11b of the stator 11, and the working fluid and the oil mist included therein are separated from each other. Only the working fluid from which the oil is separated flows upward and is discharged out from the discharge pipe 14 provided in the upper portion in the hermetical container 1. The refrigeration oil attached

to the coil end 11b of the stator 11 drops downward and is returned into the oil reservoir 16 formed in the bottom of the hermetical container 1.

(Non-patent document 1)

"Air-Conditioning and Refrigeration handbook", new edition 5, volume 11, machine", Air-Conditioning and Refrigeration Institute, 1993, paragraphs 30 to 43

(Patent document 1)

Japanese Patent Application Laid-open No.H8-28476 (paragraph 6, Figs. 1 to 3)

In the conventional compressor, a working fluid flows from the lower space 17 of the rotational motor to the upper space 19 through the notches 11a formed in the outer periphery of the stator 11 and the gap 18 between the stator 11 and the rotor 12. In the case of the compressor shown in Fig. 21, the working fluid passes through the through holes 12a of the rotor 12. The gap 18 between the stator 11 and the rotor 12 is as narrow as 0.5mm to enhance the efficiency of the rotational motor. Thus, a rate of the working fluid flowing through the gap is extremely small. Concerning the through holes 12a of the rotor 12 also, if a cross-sectional area of a laminated core of the rotor 12 is reduced and a magnetic circuit becomes narrow, the efficiency of the rotational motor is deteriorated and thus, the through holes 12a can not be increased in size. Thus, the rate of the working fluid passing through the notches 11a of the stator 11 is extremely increased.

In the conventional compressor having the structure shown in Fig. 21, only oil can be separated from the working fluid passing through the plurality of through holes 12a formed in the rotor 12 in the vertical direction, and it is difficult to separate oil from working fluid having high flow rate and passing through the notches 11a formed in the outer

periphery of the stator 11.

As shown in Figs. 19 and 20, the cluster 26 disposed in the upper space 19 is a thin and long rectangular solid and is eccentric from the axial center of the hermetical container 1. Therefore, there is generated a force which hinders a turning flow around a rotation center axis L in the upper space 19 caused by rotation of the rotor 12. Therefore, the flow velocity of turning flow is slow and uneven. Thus, the working fluid and the refrigeration oil are not separated from each other sufficiently.

When the conventional compressor using a working fluid mainly comprising carbon dioxide is applied to a refrigeration cycle, since a pressure of the working fluid discharged from the compression chamber 6 exceeds a critical pressure, the working fluid in the hermetical container 1 is brought into a supercritical state, meltage of the refrigeration oil with respect to the working fluid is increased, and it is difficult to separate oil in the hermetical container 1.

The present invention has been accomplished to solve the above problems, and it is an object of the invention to obtain a refrigeration cycle having high efficiency by easily and inexpensively enhancing the oil-separating efficiency to reduce an amount of refrigeration oil which is taken out from a hermetical container and to enhance the reliability of the compressor without deteriorating the efficiency of a rotational motor.

Disclosure of the Invention

A first aspect of the present invention provides a compressor comprising: a container; a compression mechanism disposed in a lower portion of said container; a rotational motor disposed in

an upper portion of said container, said rotational motor having a stator and a rotor; a coil end provided on each of upper and lower ends of said stator; a discharge pipe provided on an upper end of said container; an oil reservoir provided in a lower portion of said container; and a gap provided between said rotational motor and said container, said gap being operable to introduce working fluid, which is compressed by said compression mechanism, into an upper space of said container; wherein the working fluid is discharged from said container through said discharge pipe; and wherein said discharge pipe has an open end in said container, the open end being located inside said coil end provided on the upper end of said stator.

According to this aspect, since the open end in the hermetical container is located inside the coil end, the working fluid introduced into the upper space of the container from the gap between the rotational motor and the container flows from upward to downward toward the inside of the coil end, and the working fluid introduced into the coil end flows toward the open end of the discharge pipe. Therefore, when the flowing direction of the working fluid is changed in this manner, the oil mist of the refrigeration oil having high density reaches closer to the rotor than the working fluid. The oil mist of the refrigeration oil which reaches the vicinity of the rotor is separated from the working fluid by centrifugal force by means of the rotational flow caused by rotation of the rotor, and attaches to the inner peripheral surface

of the coil end. Thus, it is possible to prevent the refrigeration oil from being delivered outside of the hermetical container from the discharge pipe together with the working fluid.

According to the second aspect of the invention, in the compressor of the first aspect said discharge pipe has a curved portion in said container.

According to this aspect, it is possible to position the open end in the container inside the coil end irrespective of a position where the suction port is mounted on the container. Therefore, it is possible to largely enhancing the flexibility in design of the compressor.

According to a third aspect of the invention, in the compressor of the second aspect, said discharge pipe is provided on a side surface of said container.

With this aspect, since the discharge pipe passing through the side surface of the container has the curved portion in the hermetical container, the open end in the container can easily be located inside the coil end. Therefore, the oil is separated by the gravity caused by changing the flowing direction and by the centrifugal force of the turning flow, and it is possible to prevent the refrigeration oil from being delivered outside the container. Since the upper portion in the container can freely be used, the flexibility in design of the compressor can be enhanced.

According to the fourth aspect of the invention, in the compressor of the first aspect, the open end of said discharge pipe in said container is disposed to face downstream of a rotational direction of said rotor.

With this aspect, since the open end in the container is opened toward downstream of a rotational direction of the rotor, the oil mist of refrigeration oil having high density is prevented from being drawn

into the discharge pipe, and the oil can be separated from the working fluid more efficiently.

According to a fifth aspect of the invention, in the compressor of the first aspect, the open end of said discharge pipe in said container is located in a vicinity of a rotation center axis of said rotor.

With this aspect, since the open end in the container is located in the vicinity of the rotation center axis of the rotor, working fluid from which the oil mist is sufficiently separated can be introduced into the discharge pipe.

According to a sixth aspect of the invention, in the compressor of the first aspect, an inner diameter of the open end of said discharge pipe located inside said container is larger than an inner diameter of said discharge pipe located outside of said container.

With this aspect, since an inner diameter of the open end in the container is increased, the flow velocity of the working fluid in the vicinity of the open end in the container is reduced, and the amount of oil mist drawn together with the working fluid can be reduced.

A seventh aspect of the present invention provides

a compressor comprising: a container; a compression mechanism disposed in a lower portion of said container; a rotational motor disposed in an upper portion of said container, said rotational motor having a stator and a rotor; a coil end provided on each of upper and lower ends of said stator; a discharge pipe provided on an upper end of said container; an oil reservoir provided in a lower portion of said container; and a gap provided between said rotational motor and

said container, said gap being operable to introduce working fluid, which is compressed by said compression mechanism, into an upper space of said container; and a substantially cylindrical dividing member provided in the upper space of said container and being operable to divide the upper space into an inner space and an outer space; wherein said discharge pipe has an open end in said container, the open end being located inside said substantially cylindrical dividing member; and wherein the working fluid is discharged from said container through said discharge pipe.

With this aspect, since the dividing member is provided, the turning flow of the working fluid generated by the rotor in the inner space is not dispersed to the outer space, the development of the turning flow is accelerated, and the oil is sufficiently separated by the centrifugal force caused by the turning flow. Thus, the oil mist can attach the inner wall surface of the dividing member reliably, and the oil mist can be returned into the oil reservoir as liquid drop. Therefore, it is possible to prevent the refrigeration oil from being discharged from the discharge pipe together with the working fluid.

According to an eighth aspect of the invention, in the compressor of the seventh aspect, a gap is provided between an upper end of said dividing member and said container.

With this aspect, a narrow gap is formed in the upper portion in the hermetical container. Since the working fluid which passed through the gap spreads and flows downward in the wider inner space,

the oil mist having higher density than the working fluid which is largely affected by the gravity receives a great downward speed component, and the oil separation is facilitated.

According to a ninth aspect of the invention, in the compressor of the seventh aspect, said dividing member is provided with a communication hole between the inner space and the outer space.

With this aspect, since the dividing member is provided with the communication hole which brings the inner space and the outer space into communication with each other, the upper end of the dividing member can be brought into contact with the upper end surface in the container and fixed thereto, and the positioning precision of the dividing member when the compressor is assembled is enhanced.

According to a tenth aspect of the invention, in the compressor of any of the seventh aspects, said dividing member is provided inside said coil end provided on the upper end of said stator.

With this aspect, since the dividing member is provided inside, the region of the inner space is reduced, the dispersion of the rotational motion energy of the turning flow is suppressed, and the working fluid receives strong centrifugal force. Therefore, the oil mist separation effect by the centrifugal force is enhanced.

According to an eleventh aspect of the invention, in the compressor of any of the seventh aspects, said dividing member is provided outside said coil end provided on the upper end of said stator.

With this aspect, since the dividing member is provided outside, the coil end having complicated surface shape comes inside the dividing member. With this, the refrigeration oil attached to the surface of the coil end is prone to grow into the liquid drop, and the oil separation effect is enhanced.

According to a twelfth aspect of the invention, in the compressor

of any of the seventh aspects, an inner diameter of an upper portion of said dividing member is smaller than an inner diameter of a lower portion of said dividing member.

With this aspect, a downward component of force of the centrifugal force which is in parallel to the inner wall surface of the dividing member is applied to the liquid drop of the refrigeration oil attached to the inner wall surface, which reliably allows the liquid drop to flow and drop downward along the inner wall surface, and the oil separation effect is enhanced.

According to a thirteenth aspect of the invention, in the compressor of any of the first aspects, an upper portion of said container is domical in shape.

With this aspect, since the working fluid is smoothly collected in the central portion from the outer periphery along the inner surface of the domical container, the flow velocity of the deviation flow is prevented from being lowered. With this the oil-separating effect by the gravity and the centrifugal force is further enhanced.

A fourteenth aspect of the present invention provides a compressor comprising: a container; a compression mechanism disposed in a lower portion of said container; a rotational motor disposed in an upper portion of said container, said rotational motor having a stator and a rotor; a coil end provided on each of upper and lower ends of said stator; a discharge pipe provided on an upper end of said container; an oil reservoir provided in a lower portion of said container; a gap provided between said rotational motor and said

container, said gap being operable to introduce working fluid, which is compressed by said compression mechanism, into an upper space of said container; an introduction terminal provided in said container and being operable to supply electricity to said rotational motor; and a cluster provided in said container and being adapted to connect a lead wire from said rotational motor to said introduction terminal; wherein said cluster is symmetric with respect to an axis thereof, the axis of said cluster being substantially coincident with a rotation central axis of said rotational motor; and wherein the working fluid is discharged from said container through said discharge pipe.

With this aspect, the turning flow is generated in the upper space of the container by the high speed rotation of the rotational motor, but since the cluster is symmetric with respect to the axis and the cluster and the rotation center axis of the rotational motor substantially coincide with each other, the turning flow is also generated around the cluster. Therefore, the oil mist introduced into the upper space of the container together with the working fluid is separated by centrifugal force caused by the turning flow and the oil mist attaches to the inner wall surface of the hermetical container, and the oil mist flows and drops downward as oil drop. Therefore, the refrigeration oil is prevented from being discharged from the discharge pipe together with the working fluid.

According to a fifteenth aspect of the invention, in the

compressor of any one of the first aspects, further comprising: an introduction terminal provided in said container and being operable to supply electricity to said rotational motor; and a cluster adapted to connect a lead wire from said rotational motor to said introduction terminal, wherein said cluster is symmetric with respect to a center axis thereof, the center axis being substantially coincident with a rotation center axis of said rotational motor.

With this aspect, the turning flow is generated in the upper space of the container by the high speed rotation of the rotational motor, but since the cluster is symmetric with respect to the axis and the cluster and the rotation center axis of the rotational motor substantially coincide with each other, the turning flow is also generated around the cluster. Therefore, the oil mist introduced into the upper space of the container together with the working fluid is separated by centrifugal force caused by the turning flow and the oil mist attaches to the inner wall surface of the container, and the oil mist flows and drops downward as an oil drop. Therefore, the refrigeration oil is prevented from being discharged from the discharge pipe together with the working fluid.

According to a sixteenth aspect of the invention, in the compressor of the fourteenth aspect, said cluster is columnar in shape.

With this aspect, the generation effect of the turning flow around the cluster is enhanced.

According to a seventeenth aspect of the invention, in the compressor of the fourteenth aspect, said cluster is polygonal columnar

in shape.

With this aspect, the side surface of the polygonal shape becomes an obstruction, and downward flow along the side surface is generated. Thus, the effect for downwardly dropping the oil mist as oil drop is enhanced, and the refrigeration oil is prevented from being discharged from the discharge pipe together with the working fluid.

According to an eighteenth aspect of the invention, in the compressor of any of the fourteenth aspects, an outer diameter of said cluster is smaller than an inner diameter of said coil end.

With this aspect, the space of flow is increased, the turning flow of space inside the coil end is prone to grow to the turning flow around the cluster.

According to a nineteenth aspect of the invention, in the compressor of any of the first aspects, carbon dioxide is used as the working fluid.

With this aspect, carbon dioxide can be used as the working fluid.

Brief Description of the Drawings

Fig. 1 is a vertical sectional view of a compressor according to a first embodiment of the present invention;

Fig. 2 is a lateral sectional view of the compressor shown in Fig. 1 taken along arrows X-X;

Fig. 3 is a vertical sectional view of a compressor according to a second embodiment of the invention;

Fig. 4 is a lateral sectional view of the compressor shown in Fig. 3 taken along arrows Y-Y;

Fig. 5 is a vertical sectional view of a compressor according to a third embodiment of the invention;

Fig. 6 is a lateral sectional view of the compressor shown in Fig. 5 taken along arrows Z-Z;

Fig. 7 is a vertical sectional view of a compressor according to a fourth embodiment of the invention;

Fig. 8 is a vertical sectional view of a compressor according to a fifth embodiment of the invention;

Fig. 9 is a vertical sectional view of a compressor according to a sixth embodiment of the invention;

Fig. 10 is a vertical sectional view of a compressor according to a seventh embodiment of the invention;

Fig. 11 is a lateral sectional view of the compressor shown in Fig. 10 taken along arrows X-X;

Fig. 12 is a vertical sectional view of a compressor according to an eighth embodiment of the invention;

Fig. 13 is a vertical sectional view of a compressor according to a ninth embodiment of the invention;

Fig. 14 is a vertical sectional view of a compressor according to a tenth embodiment of the invention;

Fig. 15 is a lateral sectional view of the compressor shown in Fig. 14 taken along arrows X-X;

Fig. 16 is a lateral sectional view of the compressor shown in Fig. 14 taken along arrows Y-Y;

Fig. 17 is a lateral sectional view of the compressor shown in Fig. 14 taken along arrows Z-Z;

Fig. 18 is a lateral sectional view of a compressor according to an eleventh embodiment of the invention;

Fig. 19 is a vertical sectional view of a conventional compressor;

Fig. 20 is a perspective view of a cluster of the conventional compressor; and

Fig. 21 is a detailed sectional view of peripheries of an oil-separating plate.

Best Mode for Carrying Out the Invention

Several embodiments of the present invention will be explained below with reference to the drawings.

(First Embodiment)

Fig. 1 is a vertical sectional view of a compressor according to the first embodiment of the present invention, and Fig. 2 is a lateral sectional view of the compressor shown in Fig. 1 taken along arrows X-X. The compressor of the first embodiment of the invention has almost the same structure as that of the above-described conventional compressor, and the same elements are designated with the same symbols.

The compressor of this embodiment comprises a hermetical container 1, a compression mechanism disposed in a lower portion in the hermetical container 1, and a rotational motor disposed above the compression mechanism. The compression mechanism comprises a shaft 2 which can rotate about a rotation center axis L, a cylinder 3 having a cylindrical surface 3a therein, a roller 4 which is fitted over an eccentric portion 2a of the shaft 2 and which eccentrically rotates in the cylinder 3 as the shaft 2 rotates, a vane 7 which reciprocates in a vane groove 3b of the cylinder 3 while a tip end of the vane 7 being in contact with the roller 4 and which divides a space defined by the cylinder 3 and the roller 4 into a suction chamber 5 and a compression chamber 6, a spring 8 which is disposed on a back surface of the vane 7 and which pushes the vane 7 against the roller 4, and an upper bearing 9 and a lower bearing 10 which support the shaft 2. The upper bearing 9 includes a flow path 9a which is connected to a

suction pipe 15 and which introduces working fluid drawing from the suction pipe 15 into the suction chamber 5, and a discharging hole 9b which discharges working fluid compressed in the compression chamber 6 into the lower space 17 of the rotational motor.

The rotational motor comprises a stator 11 shrinkage fitted into the hermetical container 1, and a rotor 12 shrinkage fitted to the shaft 2. The stator 11 is provided at its upper end with a coil end 11b and at its lower end with a coil end 11d. The stator 11 is provided at its outer periphery with a plurality of notches 11a which bring the lower space 17 and the upper space 19 into communication with each other. The notches 11a serve as flow paths for working fluid.

The hermetical container 1 is provided at its upper portion with an introducing terminal 13 which energizes the rotational motor in the hermetical container 1, and a discharge pipe 31 which introduces working fluid from the upper space 19 in the hermetical container 1 into a refrigeration cycle outside the hermetical container 1. Refrigeration oil is reserved in an oil reservoir 16 formed in a bottom of the hermetical container 1.

The discharge pipe 31 is in communication with inside of the hermetical container 1. A suction port 31a as an open end of the hermetical container is located at inner side of an upper coil end 11b of the stator 11, i.e., below an upper end surface 11c of the coil end 11b. The discharge pipe 31 is a straight pipe, and is mounted on an upper portion of the hermetical container 1 at a location closer to a center than an inner diameter of the coil end 11b. Thus, the introducing terminal 13 is mounted at a position of the upper portion of the hermetical container 1 where the mounting of the discharge pipe 31 is not hindered. In this embodiment, the through holes 12a (see Fig. 11) of the rotor 12 by the same oil-separating plate method as

that of the conventional technique is not provided.

Next, the operation of the compressor having the above-described structure will be explained. The working fluid is introduced from the suction pipe 15 into the suction chamber 5 through the flow path 9a provided in the upper bearing 9. If the rotational motor is energized and the shaft 2 which is integral with the rotor 12 is rotated, the roller 4 eccentrically rotates, the capacities of the suction chamber 5 and the compression chamber 6 are varied. With this, the working fluid is drawn and compressed. When a discharge valve (not shown) of the discharging hole 9b is opened, oil mist which is supplied from the oil reservoir 16 and which lubricated the compression mechanism is mixed into the compressed working fluid, and this mixture is discharged into the lower space 17 of the rotational motor. The working fluid in the lower space 17 passes through notches 11a formed in the outer periphery of the stator 11 as gaps between the rotational motor and the hermetical container 1, and through a gap 18 (air gap) between the stator 11 and the rotor 12, and flows into the upper space 19 of the rotational motor. The working fluid is separated from the refrigeration oil in the upper space 19, and is discharged from the discharge pipe 14.

This oil-separating operation will be explained. As described above, the working fluid including oil mist discharged from the compression mechanism into the lower space 17 of the rotational motor passes through the notches 11a of the stator 11 and the gap 18 between the stator 11 and the rotor 12, and moves into the upper space 19 of the rotational motor. At that time, since the gap 18 is extremely narrow, the rate of working fluid passing through the notches 11a of the stator 11 becomes extremely large.

The working fluid which passed through the notches 11a of the

stator 11 flows upward to the vicinity of the coil end 11b of the stator 11 and then, flows toward a central portion of the hermetical container 1 through an upper portion of the coil end 11b. Thereafter, the working fluid flows downward toward the suction port 31a of the discharge pipe 31 which is disposed inside the coil end 11b and directed downward. When the working fluid is drawn into the suction port 31a of the discharge pipe 31, the working fluid again flows upward. At that time, the oil mist having high density drop downward due to gravity, and reaches closer to an upper surface 12b of the rotor 12 as compared with the working fluid.

Since the upper surface 12b of the rotor 12 is rotational immediately below the suction port 31a of the discharge pipe 31, the working fluid flows such as to turn due to the viscosity, and as closer to the upper surface 12b of the rotor 12, the turning flow velocity is increased. Therefore, the oil mist has higher density than the working fluid and the oil mist reaches a region where the flow velocity of the turning flow in the vicinity of the upper surface 12b of the rotor 12 is greater. Thus, the oil mist attaches to an inner peripheral surface of the stator 11 or the coil end 11b by the centrifugal force and becomes liquid drop and is returned to the oil reservoir 16 formed in the bottom of the hermetical container 1. In the state which the refrigeration oil is separated from the working fluid which is less affected by the turning flow, the working fluid is introduced into the suction port 31a of the discharge pipe 31.

The suction port 31a is located inside the coil end 11b in this embodiment as described above. Therefore, when the working fluid flowing from the notches 11a toward the suction port 31a flows through the upper space 19 upward, downward and upward, the gravity acts on the oil mist, and when the working fluid entering into the coil end

11b and coming into contact with the rotor 12 turns together with the rotor 12 by the viscosity, the centrifugal force is applied to the oil mist and the refrigeration oil is separated from the working fluid. With this, an amount of the refrigeration oil delivered to the refrigeration cycle out from the compressor together with the working fluid can be reduced. The refrigeration oil is not attached to an inner wall of a heat exchanger tube of a heat exchanger, and it is possible to prevent the heat exchanging efficiency from being deteriorated. An amount of refrigeration oil in the oil reservoir 16 can always be maintained constantly, and it is possible to enhance the reliability and efficiency of the compressor.

Further, it is only necessary to extend the discharge pipe and to locate the suction port inside the coil end close to the upper end of the stator. Therefore, oil can be separated easily only with slight change, and it is possible to provide a compressor extremely inexpensively.

(Second Embodiment)

A compressor according to the second embodiment of the present invention has the same structure as that of the compressor of the first embodiment as shown in Figs. 1 and 2 except the discharge pipe and the introducing terminal. The same elements are designated with the same symbols.

Fig. 3 is a vertical sectional view of a compressor according to the second embodiment of the invention, and Fig. 4 is a lateral sectional view of the compressor shown in Fig. 3 taken along arrows Y-Y. The compressor of this embodiment comprises the hermetical container 1, the compression mechanism disposed at a lower portion in the hermetical container 1 and having the shaft 2, the cylinder 3, the roller 4, the vane 7 and the like. The compressor also comprises

the rotational motor disposed above the compression mechanism and having the stator 11, the rotor 12 and the like. Refrigeration oil is reserved in the oil reservoir 16 formed in the bottom of the hermetical container 1. In an upper portion of the hermetical container 1, there are provided the introducing terminal 13 for energizing the rotational motor in the hermetical container 1, and the discharge pipe 32 for introducing the working fluid from the hermetical container 1 into the refrigeration cycle.

The discharge pipe 32 extends into the hermetical container 1, and has a curved portion 32b inside the hermetical container 1. A suction port 32a of the discharge pipe 32 is located inside the coil end 11b on the upper end of the stator 11. The suction port 32a of the discharge pipe 32 is located closer to an inner peripheral surface of the coil end 11b than a central portion of the hermetical container 1. The suction port 32a extends diagonally downward toward substantially the downstream in the rotation direction of the upper surface 12b of the rotor 12. In this embodiment, the through holes 12a (see Fig. 11) of the rotor 12 is not provided.

The oil-separating operation of the compressor having the above structure will be explained. The working fluid including oil mist discharged from the compression mechanism into the lower space 17 of the rotational motor passes through the notches 11a of the stator 11 and the gap 18 between the stator 11 and the rotor 12 and moves to the upper space 19 of the rotational motor. At that time, since the gap 18 is extremely narrow, the rate of working fluid passing through the notches 11a of the stator 11 becomes extremely large.

The working fluid which passed through the notches 11a of the stator 11 flows upward to the vicinity of the coil end 11b of the stator 11 and then, flows toward a central portion of the hermetical container

1 through an upper portion of the coil end 11b. Thereafter, the working fluid flows downward toward the suction port 32a of the discharge pipe 32 which is disposed inside the coil end 11b. Then, the working fluid is drawn into the suction port 32a and again flows upward. Since the suction port 32a of the discharge pipe 32 extends diagonally downward as in the first embodiment, the oil-separating effect of the refrigeration oil when the flow of the working fluid is changed from downward to the upward can be obtained.

If the working fluid reaches the vicinity of the suction port 32a of the discharge pipe 32, since the upper surface 12b of the rotor 12 is rotational immediately below the suction port 32a, the working fluid turns by the viscosity. Since the suction port 32a of the discharge pipe 32 is directed downstream of the turning flow, when the turning flow is drawing from the suction port 32a, the direction of the flow is abruptly changed from the downstream direction to the upstream direction with respect to the turning flow. At that time, the oil mist having high density flows further downstream by the inertial force and at the same time, the oil mist attaches to the inner peripheral surface of the coil end 11b and becomes liquid drop by the centrifugal force of the turning flow, and the oil mist is returned to the oil reservoir 16 formed in the bottom of the hermetical container 1 by the gravity. In the state which the refrigeration oil is separated from the working fluid which is less affected by the turning flow, the working fluid is introduced into the suction port 32a of the discharge pipe 32.

According to the second embodiment, since the suction port 32a is located inside the coil end 11b and is opened toward the downstream of the rotational direction of the rotor 12, the oil-separating effect is further enhanced as compared with the first embodiment by the change

of flowing direction of the working fluid, and by the gravity and the centrifugal force applied to the oil mist which turns, and by the inertial force applied to the oil mist when the flowing direction of the working fluid is changed from the downstream flowing to the upstream flowing. With this, it is possible to further suppress the amount of refrigeration oil delivered to the refrigeration cycle outside the compressor together with the working fluid. The refrigeration oil is not attached to an inner wall of a heat exchanger tube of a heat exchanger, and it is possible to more efficiently prevent the heat exchanging efficiency from being deteriorated. An amount of refrigeration oil in the oil reservoir 16 can always be maintained constantly, and it is possible to further enhance the reliability and efficiency of the compressor.

Since the discharge pipe 32 has the curved portion 32b, it is possible to position the suction port 32a inside the coil end 11b irrespective of a position where the suction port 32a is mounted on the hermetical container 1. Therefore, it is possible to give a high priority to the position of the introducing terminal 13 and the like in the upper portion in the hermetical container 1, and the flexibility in design can largely be enhanced. For example, it is unnecessary to deviate the mounting position of the introducing terminal 13 so that the introducing terminal 13 does not hinder the discharge pipe 31 unlike the first embodiment, and the introducing terminal 13 can be disposed in the center of the container.

(Third Embodiment)

A compressor according to the third embodiment of the present invention has the same structure as that of the compressor of the second embodiment as shown in Figs. 3 and 4 except the discharge pipe. The same elements are designated with the same symbols.

Fig. 5 is a vertical sectional view of a compressor according

to the third embodiment of the invention, and Fig. 6 is a lateral sectional view of the compressor shown in Fig. 5 taken along arrows Z-Z. The compressor of this embodiment comprises the hermetical container 1, the compression mechanism disposed at a lower portion in the hermetical container 1 and having the shaft 2, the cylinder 3, the roller 4, the vane 7 and the like. The compressor also comprises the rotational motor disposed above the compression mechanism and having the stator 11, the rotor 12 and the like. Refrigeration oil is reserved in the oil reservoir 16 formed in the bottom of the hermetical container 1. In an upper portion of the hermetical container 1, there are provided the introducing terminal 13 for energizing the rotational motor in the hermetical container 1, and the discharge pipe 33 for introducing the working fluid from the hermetical container 1 into the refrigeration cycle.

The discharge pipe 33 extends into the hermetical container 1, and has a curved portion 33b inside the hermetical container 1. A suction port 33a of the discharge pipe 33 is located inside the coil end 11b on the upper end of the stator 11. The suction port 33a of the discharge pipe 33 is disposed in the vicinity of the rotation center axis L of the rotor 12 and is directed diagonally downward. In this embodiment, the through holes 12a (see Fig. 11) of the rotor 12 is not provided.

This oil-separating operation will be explained. As described above, the working fluid including oil mist discharged from the compression mechanism into the lower space 17 of the rotational motor passes through the notches 11a of the stator 11 and the gap 18 between the stator 11 and the rotor 12, and moves into the upper space 19 of the rotational motor. At that time, since the gap 18 is extremely narrow, the rate of working fluid passing through the notches 11a of

the stator 11 becomes extremely large.

The working fluid which passed through the notches 11a of the stator 11 flows upward to the vicinity of the coil end 11b of the stator 11 and then, flows toward a central portion of the hermetical container 1 through an upper portion of the coil end 11b. Thereafter, the working fluid flows downward toward the suction port 33a of the discharge pipe 33 located inside the coil end 11b. Then, the working fluid is drawn into the suction port 33a which is directed diagonally downward and again flows upward. With this change in flowing direction, the oil mist having high density drops downward by the gravity, and the refrigeration oil is separated.

If the working fluid reaches the vicinity of the suction port 33a of the discharge pipe 33, since the upper surface 12b of the rotor 12 is rotational immediately below the suction port 33a, the working fluid turns by the viscosity. At that time, since the oil mist has higher density than that of the working fluid, the oil mist moves outward by the centrifugal force, the oil mist attaches to the inner peripheral surface of heat exchanger stator 11 or the coil end 11b and becomes liquid drop, and is returned to the oil reservoir 16 formed in the bottom of the hermetical container 1. Since the suction port 33a of the discharge pipe 33 is located at substantially the central portion in the turning flow in the vicinity of the rotation center axis L, the oil mist which is largely affected by the centrifugal force is removed substantially completely, and the refrigeration oil is separated from the working fluid which is less affected by the centrifugal force, and the working fluid is introduced into the suction port 33a of the discharge pipe 33.

The oil-separating efficiency by the centrifugal force will be further enhanced if the following structure (not shown) is employed.

That is, the introducing terminal 13 is disposed on the upper end of the hermetical container 1, the discharge pipe 33 passes through from the center of the upper portion of the hermetical container 1, and the suction port 33a is straight in shape and is located inside the coil end 11b.

According to this embodiment, the suction port 33a is located inside the coil end 11b. With this structure, the oil mist can be removed by the gravity of the change of flowing direction. Further, since the suction port 33a is opened in the vicinity of the rotation center axis L of the rotor 12, the working fluid from which the oil mist is sufficiently removed can be drawn by the effect of the centrifugal force of the turning flow. Thus, the oil-separating operation is further facilitated as compared with the first embodiment. With this, it is possible to further suppress the amount of refrigeration oil delivered to the refrigeration cycle outside the compressor together with the working fluid. The refrigeration oil is not attached to an inner wall of a heat exchanger tube of a heat exchanger, and it is possible to more efficiently prevent the heat exchanging efficiency from being deteriorated. An amount of refrigeration oil in the oil reservoir 16 can always be maintained constantly, and it is possible to further enhance the reliability and efficiency of the compressor.

(Fourth Embodiment)

A compressor according to the fourth embodiment of the present invention has the same structure as that of the compressor of the first embodiment as shown in Figs. 1 and 2 except the discharge pipe and the introducing terminal. The same elements are designated with the same symbols.

Fig. 7 is a vertical sectional view of a compressor according to the fourth embodiment of the invention. The compressor of this

embodiment comprises the compression mechanism disposed at a lower portion in the hermetical container 1 and having the shaft 2, the cylinder 3, the roller 4, the vane 7 and the like. The compressor also comprises the rotational motor disposed above the compression mechanism and having the stator 11, the rotor 12 and the like. Refrigeration oil is reserved in the oil reservoir 16 formed in the bottom of the hermetical container. The introducing terminal 13 for energizing the rotational motor in the hermetical container 1 is provided in an upper portion of the hermetical container 1. The hermetical container 1 is provided at its side surface with a discharge pipe 34 for introducing working fluid from the hermetical container 1 into the refrigeration cycle. The discharge pipe 34 passes through the side surface of the hermetical container 1, and has a curved portion 34b. A suction port 34a as an open end of the hermetical container is located inside the coil end 11b of the stator 11. In this embodiment, the through holes 12a (see Fig. 11) of the rotor 12 is not provided.

According to the compressor of the fourth embodiment having such a structure, since the suction port 34a of the discharge pipe 34 is located inside the coil end 11b as in the first embodiment, the same effect as that of the first embodiment can be obtained of course and thus, detailed explanation thereof will be omitted.

In the compressor of this embodiment, the discharge pipe 34 passes through the side surface of the hermetical container 1, an upper portion in the hermetical container 1 can be used freely, and layout of the introducing terminal 13 is not limited. When the compressor is mounted in the refrigeration cycle, even if a high pressure side pipe is directed laterally, the discharge pipe 34 can be connected directly, and there is effect that the structure of the refrigeration cycle becomes simple. In other words, the flexibility in design of

the compressor can largely be enhanced.

The same effect as that of the second embodiment can be obtained if the following structure is employed. That is, in the compressor of the fourth embodiment, the suction port 34a of the discharge pipe 34 is disposed closer to the inner peripheral surface of the coil end 11b than the central portion of the hermetical container 1 as in the second embodiment, and the suction port 34a is directed toward substantially the downstream in the rotation direction of the upper surface 12b of the rotor 12.

In the compressor of the fourth embodiment, the same effect as that of the third embodiment can be obtained if the suction port 34a of the discharge pipe 34 is disposed in the vicinity of the rotation center axis L as in the third embodiment.

(Fifth Embodiment)

A compressor according to the fifth embodiment of the present invention has the same structure as that of the compressor of the first embodiment as shown in Figs. 1 and 2 except the discharge pipe. The same elements are designated with the same symbols.

Fig. 8 is a vertical sectional view of a compressor according to the fifth embodiment of the invention. The compressor of this embodiment comprises the compression mechanism disposed at a lower portion in the hermetical container 1 and having the shaft 2, the cylinder 3, the roller 4, the vane 7 and the like. The compressor also comprises the rotational motor disposed above the compression mechanism and having the stator 11, the rotor 12 and the like. Refrigeration oil is reserved in the oil reservoir 16 formed in the bottom of the hermetical container. In an upper portion of the hermetical container 1, there are provided the introducing terminal 13 for energizing the rotational motor in the hermetical container 1, and the discharge pipe 35 for introducing

the working fluid from the hermetical container 1 into the refrigeration cycle.

The discharge pipe 35 is mounted in an upper portion of the hermetical container 1 closer to the center thereof than an inner diameter of the coil end 11b, and passes through the hermetical container 1. A suction port 35a of the discharge pipe 35 is located inside the coil end 11b of the stator 11. The discharge pipe 35 is straight pipe having a step, i.e., an inner diameter of the discharge pipe 35 in the vicinity of the suction port 35a is enlarged. In this embodiment, the through holes 12a (see Fig. 11) of the rotor 12 is not provided.

According to the compressor of the fifth embodiment having such a structure, since the suction port 35a of the discharge pipe 35 is located inside the coil end 11b as in the first embodiment, the same effect as that of the first embodiment can be obtained of course.

As the flow velocity of the working fluid at the suction port 35a is greater, the refrigeration oil near the suction port 35a is more prone to be drawn together with the working fluid before the refrigeration oil is separated from the working fluid by the gravity and the centrifugal force. However, since the inner diameter of the discharge pipe 35 in the vicinity of the suction port 35a is enlarged, the flow velocity of the working fluid in the vicinity of the suction port 35a of the discharge pipe 35 is smaller as compared with a case in which the inner diameter is enlarged. Therefore, the amount of oil mist which is drawn together with the working fluid can be reduced, and the refrigeration oil-separating effect of the first to third embodiments can further be enhanced.

The same effect as that of the second embodiment can be obtained if the following structure is employed. That is, in the compressor of the fifth embodiment, the suction port 35a of the discharge pipe

35 is disposed closer to the inner peripheral surface of the coil end 11b than the central portion of the hermetical container 1 as in the second embodiment, and the suction port 35a is directed diagonally downward toward substantially the downstream in the rotation direction of the upper surface 12b of the rotor 12.

In the compressor of the fifth embodiment, the same effect as that of the third embodiment can be obtained if the suction port 35a of the discharge pipe 35 is disposed in the vicinity of the rotation center axis L as in the third embodiment and the discharge pipe 35 is directed diagonally downward.

(Sixth Embodiment)

A compressor according to the sixth embodiment of the present invention has the same structure as that of the compressor of the second embodiment as shown in Figs. 3 and 4 except the hermetical container and the discharge pipe. The same elements are designated with the same symbols.

Fig. 9 is a vertical sectional view of a compressor according to the sixth embodiment of the invention. According to the compressor of this embodiment, the compression mechanism comprising the shaft 2, the cylinder 3, the roller 4, the vane 7 and the like is disposed in a lower portion in a hermetical container 36, and the rotational motor comprising the stator 11 and the rotor 12 is disposed in an upper portion in the hermetical container 36. Refrigeration oil is reserved in the oil reservoir 16 formed in the bottom of the hermetical container 36. Each of the upper portion of the bottom (including inner surface of the container) of the hermetical container 36 is domical in shape which comprises a combination of a peripheral r-portion 36a having a smaller diameter and an inner R-portion 36b having a larger diameter.

The introducing terminal 13 for energizing the rotational motor

in the hermetical container 36 and a discharge pipe 37 for introducing working fluid from the hermetical container 36 into the refrigeration cycle are provided in an upper portion of the hermetical container 36. The discharge pipe 37 passes through the hermetical container 36, and the suction port 37a is located inside the coil end 11b on the upper end of the stator 11.

According to the compressor of the sixth embodiment having such a structure, since the suction port 37a of the discharge pipe 37 is located inside the coil end 11b as in the first embodiment, the same effect as that of the first embodiment can be obtained of course.

The working fluid which passed through the notches 11a of the stator 11 flows upward to the vicinity of the coil end 11b of the stator 11 and then, passes through the upper portion of the coil end 11b and flows toward the center of the hermetical container 36. Here, since at least the upper portion of the hermetical container 36 is domical in shape, the working fluid flows toward the center of the hermetical container 36 along the r-portion 36a and the R-portion 36b, and it is possible to prevent the flow velocity from being lowered. Therefore, after that, the downward flow velocity toward the suction port 37a of the discharge pipe 37 located inside the coil end 11b is also increased. When the working fluid is drawn into the suction port 37a of the discharge pipe 37, the flow of the working fluid is again changed into the upward flow, but the oil-separating effect by the gravity and the centrifugal force at that time can further be enhanced.

Since the hermetical container 36 is domical in shape, the refrigeration cycle is a supercritical cycle of working fluid having carbon dioxide as main composition. Thus, even when a pressure in the hermetical container 36 is extremely high, the strength of the hermetical container 36 can be maintained and safety can be secured.

In the compressors of the first to sixth embodiments, working fluid having the environment-friendly carbon dioxide as main composition, the working fluid in the hermetical container 1 or 36 is in the supercritical state, and the meltage of the refrigeration oil with respect to the working fluid is increased. Thus, the oil-separating effect obtained by the gravity and the centrifugal force is enhanced, and the object of the present invention can be achieved. (Seventh Embodiment)

Fig. 10 is a vertical sectional view of a compressor according to the seventh embodiment of the invention, and Fig. 11 is a lateral sectional view of the compressor shown in Fig. 10 taken along arrows X-X. The compressor according to the seventh embodiment of the present invention has almost the same structure as that of the conventional compressor. The same elements are designated with the same symbols.

The compressor of this embodiment comprises the hermetical container 1, the compression mechanism disposed in a lower portion in the hermetical container 1, and the rotational motor disposed in an upper portion in the hermetical container 1. The compression mechanism comprises the shaft 2 capable of rotational around the rotation center axis L, the cylinder 3 having the cylindrical surface 3a therein, the roller 4 fitted over the eccentric portion 2a of the shaft 2 and eccentrically rotational inside the cylinder 3 with the rotation of the shaft 2, the vane 7 which reciprocates within the vane groove 3b of the cylinder 3 while a tip end of the vane 7 being in contact with the roller 4 and which divides a space defined by the cylinder 3 and the roller 4 into the suction chamber 5 and the compression chamber 6, the spring 8 which is disposed on a back surface of the vane 7 and which pushes the vane 7 against the roller 4, and the upper bearing 9 and a lower bearing 10 which support the shaft 2. The upper

bearing 9 includes a flow path 9a which is connected to the suction pipe 15 and which introduces working fluid drawing from the suction pipe 15 into the suction chamber 5, and the discharging hole 9b which discharges working fluid compressed in the compression chamber 6 into the lower space 17 of the rotational motor.

The rotational motor comprises the stator 11 shrinkage fitted into the hermetical container 1, and the rotor 12 which is shrinkage fitted to the shaft 2 and rotates in the inner periphery of the stator 11. The stator 11 is provided at its upper end with the coil end 11b and at its lower end with the coil end 11d. The stator 11 is provided at its outer periphery with a plurality of notches 11a which bring the lower space 17 and the upper space 19 into communication with each other. The notches 11a serve as flow paths for working fluid. Refrigeration oil is reserved in the oil reservoir 16 formed in the bottom of the hermetical container 1.

A thin cylinder 41 as a dividing member is fitted over the coil end 11b formed on the upper end of the stator 11, and an upper space 19 of the rotational motor is divided by the thin cylinder 41 into an inner space 19a and an outer space 19b. This thin cylinder 41 is made of insulative Teflon (registered trademark), and its thickness of about 1mm. The thin cylinder 41 has a bent portion 41a formed in the vicinity of the upper end surface 11c of the coil end 11b. An inner diameter of the bent portion 41a of the thin cylinder 41 is reduced toward its top, and a gap 44 serving as a flow path of the working fluid is formed between an upper end 41b of the thin cylinder 41 and an upper end surface 1a of the hermetical container 1.

The introducing terminal 13 for energizing the rotational motor in the hermetical container 1 and the discharge pipe 40 for introducing the working fluid from the upper space 19 in the hermetical container

1 into the refrigeration cycle are provided in an upper portion in the hermetical container 1. The discharge pipe 40 passes through the hermetical container 1, and has a curved portion 40b inside the hermetical container 1. A suction port 40a of the discharge pipe 40 as an open end of the hermetical container is located below the gap 44 inside the thin cylinder 41 (i.e., inside the inner space 19a). That is, the suction port 40a is disposed at a lower position than the upper end 41b of the thin cylinder 41. The suction port 40a of the discharge pipe 40 is disposed in the vicinity of the rotation center axis L of the rotor 12 and is directed diagonally downward. Therefore, the introducing terminal 13 is mounted at a position where the mounting of the discharge pipe 40 provided on the upper portion of heat exchanger hermetical container 1 is not hindered. In this embodiment, the through holes 12a (see Fig. 6) of the rotor 12 by the same oil-separating plate method as that of the conventional technique is not provided.

Next, the operation of the compressor having the above-described structure will be explained. The working fluid is introduced from the suction pipe 15 into the suction chamber 5 through the flow path 9a provided in the upper bearing 9. If the rotational motor is energized and the shaft 2 which is integral with the rotor 12 is rotated, the roller 4 eccentrically rotates, the capacities of the suction chamber 5 and the compression chamber 6 are varied. With this, the working fluid is drawn and compressed. When a discharge valve (not shown) of the discharging hole 9b is opened, oil mist which is supplied from the oil reservoir 16 and which lubricated the compression mechanism is mixed into the compressed working fluid, and this mixture is discharged into the lower space 17 of the rotational motor. The working fluid in the lower space 17 passes through notches 11a formed in the outer periphery of the stator 11 as gaps between the hermetical container

1 and the rotational motor formed on the outer periphery of the stator 11, and through a gap 18 (air gap) between the stator 11 and the rotor 12, and flows into the upper space 19 of the rotational motor. The working fluid is separated from the refrigeration oil in the upper space 19, and is discharged from the discharge pipe 14.

This oil-separating operation will be explained. As described above, the working fluid including oil mist discharged from the compression mechanism into the lower space 17 of the rotational motor passes through the gap 18 between the stator 11 and the rotor 12 and the notches 11a of the stator 11, and moves into the inner space 19a and the outer space 19b of the upper space 19 of the rotational motor. At that time, since the gap 18 is extremely narrow, the rate of working fluid passing through the notches 11a of the stator 11 becomes extremely large.

The working fluid which flowed into the outer space 19b of the thin cylinder 41 through the notches 11a of the stator 11 passes through the gap 44 between the upper end 41b of the thin cylinder 41 and the upper end surface 1a in the hermetical container 1, and flows into the inner space 19a of the thin cylinder 41. The working fluid in the inner space 19a of the thin cylinder 41 is drawn into the suction port 40a located below the gap 44, and is discharged into the outside refrigeration cycle. Since the rotor 12 rotates at high speed in the inner space 19a of the thin cylinder 41, a turning flow around the rotation center axis L is generated in the working fluid in the inner space 19a of the thin cylinder 41.

The oil-separating operation and its effect will be explained in detail.

The thin cylinder 41 is fitted over the coil end 11b and the upper space 19 of the rotational motor is divided into the inner space

19a and the outer space 19b of the thin cylinder 41. Therefore, it is possible to limit the flow path of the working fluid which flowed into the upper space 19 through the notches 11a of the stator 11.

That is, since there is provided the thin cylinder 41 which divides the upper space 19 into the inner space 19a and the outer space 19b, it is possible to prevent the turning flow of the inner space 19a of the thin cylinder 41 from being dispersed to the outer space 19b of the thin cylinder 41. Thus, attenuation of rotational motion energy is suppressed. Therefore, it becomes easily to maintain the turning flow velocity of the inner space 19a of the thin cylinder 41 in a portion of the coil end 11b higher than the upper end surface 11c, and strong centrifugal force is applied to the working fluid and oil mist which flow toward the suction port 40a provided in a lower portion of the gap 44 through the gap 44 between the upper end 41b of the thin cylinder 41 and the upper end surface 1a in the hermetical container 1. Therefore, the oil mist having higher density than the working fluid attaches to the inner side surface of the thin cylinder 41 and becomes liquid drop. Since the the liquid drop has higher density than the working fluid, the liquid drop flows lower than the working fluid and is separated from the working fluid.

Since the gap 44 is provided between the upper end 41b of the thin cylinder 41 and the upper end surface 1a in the hermetical container 1, the working fluid which passed through the notches 11a of the stator 11 and which includes oil mist flows upward to the vicinity of the upper end of the hermetical container 1 through the outer space 19b and then, passes through the gap 44 and flows into the inner space 19a of the thin cylinder 41. The gap 44 is formed immediately below the upper end surface 1a in the hermetical container 1 and the inner space 19a of the thin cylinder 41 spreads below the gap 44. Thus,

the working fluid which flowed into the inner space 19a of the thin cylinder 41 forms a flow having downward flow velocity component while enlarging the flow width. The oil mist mixed into the working fluid which flows downward receives downward flow velocity component from the peripheral working fluid. Since the oil mist has higher density than the working fluid and gravity acting on the refrigeration oil is greater than gravity acting on the working fluid, the oil mist has greater downward velocity component than the working fluid. Thus, the oil mist flows downward of the working fluid and is separated from the working fluid. That is, since the working fluid flows into the inner space 19a of the thin cylinder 41 through the gap 44 between the upper end 41b of the thin cylinder 41 and the upper end surface 1a in the hermetical container 1, the oil mist is separated from the working fluid.

In this embodiment, since the discharge pipe 40 passes through the hermetical container 1 and the suction port 40a of the discharge pipe 40 is located lower than the gap 44 at the inner space 19a of the thin cylinder 41, the working fluid flowing into the inner space 19a from the gap 44 flows more downward toward the suction port 40a. Thus, the oil mist receives strong downward external force from the working fluid, and the oil mist is prone to be separated from the working fluid. The suction port 40a of the discharge pipe 40 opens diagonally downward, and the flowing direction of the working fluid drawn into the suction port 40a is abruptly changed from downward to upward. Thus, the oil mist which is attracted by the suction port 40a and flows downward has higher density and greater inertial force than the working fluid. Thus, the oil mist downwardly flows into the upper surface 12b of the rotor 12 without changing the flowing direction to the upward. The working fluid having lower density and smaller inertial force than

the refrigeration oil is drawing into the suction port 40a. Thus, the working fluid and the oil mist are separated from each other.

Since the rotor 12 is rotational in the inner space 19a of the thin cylinder 41, the turning flow is generated in viscosity in the vicinity of the upper surface 12b of the rotor 12. As the working fluid in the inner space 19a of the thin cylinder 41 reaches the vicinity of the upper surface 12b of the rotor 12 by a shearing force received from the turning flow, the flow velocity component in the rotational direction is increased. In a portion of the coil end 11b higher than the upper end surface 11c, a region which receives heat exchanger influence of the turning flow is increased to the inner side surface of the thin cylinder 41 fitted over the coil end 11b and thus, the flow velocity in the rotational direction of the working fluid is abruptly reduced. However, since the inner side surface of the thin cylinder 41 is cylindrical in shape, the loss of the flow velocity in the rotational direction of the working fluid given by the inner side surface of the thin cylinder 41 higher than the upper end surface 11c of the coil end 11b becomes extremely small.

Further, since a higher portion of bent portion 41a of the thin cylinder 41 has smaller inner diameter, an external force acting toward the inner side surface of the thin cylinder 41 by the centrifugal force of the working fluid which rotates inside is applied to the liquid drop of the refrigeration oil attached to the upper portion of the bent portion 41a of the thin cylinder 41. A component of force perpendicular to the inner side surface of the thin cylinder 41 of the external force acting toward the inner side surface of the thin cylinder 41 is in balance with a reaction force from the inner side surface of the thin cylinder 41, but there remains a component of force which is parallel to the inner side surface of the thin cylinder 41.

Therefore, a downward force which is in parallel to the inner side surface of the thin cylinder 41 acts on the liquid drop of the refrigeration oil attached to the upper portion of the bent portion 41a of the thin cylinder 41, and the downward flow of the working fluid is accelerated.

Oil mist which is not attached to the inner side surface of the thin cylinder 41 and is not drawn into the suction port 40a of the discharge pipe 40 has higher density than the working fluid in a lower portion of the suction port 40a of the discharge pipe 40, the oil mist reaches nearer to the upper surface 12b of the rotor 12 than the working fluid.

Since the thin cylinder 41 is fixed to the outer side of the coil end 11b, oil mist which received greater turning flow velocity and greater centrifugal force in the vicinity of the upper surface 12b of the rotor 12 attaches to the coil end 11b which comprises a plurality of copper wires and provided at its surface with complicated bumps and dips. Therefore, the oil mist is prone to grow into the liquid drop and the oil mist is separated from the working fluid easily.

With the above effect, the refrigeration oil which grew into the liquid drop from the fog drip and which was separated from the working fluid passes through the gap 18 between the stator 11 and the rotor 12 by the gravity, and is returned into the oil reservoir 16 formed in the bottom of the hermetical container 1. The working fluid having smaller centrifugal force caused by turning flow than the refrigeration oil and collected to the center of the inner space 19a of the thin cylinder 41 is introduced into the suction port 40a of the discharge pipe 40 in a state where the refrigeration oil is separated from the working fluid.

As described above, in this embodiment, an amount of the

refrigeration oil delivered to the refrigeration cycle out from the compressor together with the working fluid can be reduced. The refrigeration oil is not attached to an inner wall of a heat exchanger tube of a heat exchanger, and it is possible to prevent the heat exchanging efficiency from being deteriorated. An amount of refrigeration oil in the oil reservoir 16 can always be maintained constantly, and it is possible to enhance the reliability and efficiency of the compressor.

In this embodiment, the thin cylinder 41 is fitted over the coil end 11b, the gap is provided between the upper end of the thin cylinder 41 and the upper end surface in the hermetical container 1, and the discharge pipe 40 is extended and its suction port 40a is located inside the thin cylinder 41. Therefore, the effect of this embodiment can easily be obtained only by slightly changing the conventional compressor, and the compressor is extremely inexpensive.

(Eighth Embodiment)

Fig. 12 is a vertical sectional view of a compressor according to the eighth embodiment of the invention. The compressor according to the eighth embodiment of the present invention has the same structure as that of the compressor of the seventh embodiment as shown in Figs. 10 and 11 except the thin cylinder. The same elements are designated with the same symbols. Explanation of the same structure and effect as those of the seventh embodiment will be omitted.

In the compressor of this embodiment, a thin cylinder 42 as a dividing member is fitted into the coil end 11b on the upper end of the stator 11, and the upper space 19 of the rotational motor is divided by the thin cylinder 42 into the inner space 19a and the outer space 19b. An inner diameter of an inner side surface of the thin cylinder 42 is reduced from its lower end toward the upper end. A gap 44 is provided between the upper end 42b of the thin cylinder 42

and the upper end surface 1a in the hermetical container 1.

Nest the oil-separating operation of the thin cylinder 42 and its effect will be explained.

The rotational motion energy caused by shrinkage fit is given to the working fluid in the inner space 19a of the thin cylinder 42 by a turning flow generated in the vicinity of the upper surface 12b of the rotor 12, and the turning flow is generated in the working fluid. However, by fitting the thin cylinder 42 into the coil end 11b, a region of the inner space 19a is reduced as compared with a case in which the thin cylinder 42 is fitted over the coil end 11b and thus, the dispersion of the rotational motion energy is suppressed. Thus, as compared with the seventh embodiment, the turning flow velocity of the inner space 19a of the thin cylinder 42 is increased as a whole. The working fluid which flowed into the inner space 19a from the gap 44 of the upper end 42b of the thin cylinder 42 receives stronger centrifugal force than the seventh embodiment. Therefore, oil mist is prone to attach to the inner side surface of the thin cylinder 42 due to a difference in centrifugal force caused by difference in density between the working fluid and the refrigeration oil, the growth of the oil mist into the liquid drop is facilitated, and the refrigeration oil is separated from the working fluid easily.

Since the thin cylinder 42 is fitted into the coil end 11b, there is no obstruction in the thin cylinder 42 which limits the flexibility in shape of the thin cylinder 42. Therefore, the inner diameter of the inner side surface of the thin cylinder 42 can further be reduced from its lower end toward its upper ends as compared with the compressor of the seventh embodiment. Thus, the component of force perpendicular to the inner side surface of the thin cylinder 42 of the centrifugal force applied to the liquid drop of the refrigeration

oil attached to the inner side surface of the thin cylinder 42 is brought into balance with the reaction force from the inner side surface of the thin cylinder 42, and there remains a component of force which is parallel to the inner side surface of the thin cylinder 42 of the centrifugal force applied to the liquid drop of the refrigeration oil attached to the inner side surface of the thin cylinder 42. Therefore, the downward flow of the liquid drop of the refrigeration oil attached to the inner side surface from the lower end to the upper end of the thin cylinder 42 is accelerated, and the refrigeration oil is returned into the oil reservoir 16 formed in the bottom of the hermetical container 1 more easily as compared with the compressor of the seventh embodiment.

In addition to the above-described effect, the eighth embodiment can obtain the effect of the seventh embodiment of course.

As described above, in this embodiment, an amount of the refrigeration oil delivered to the refrigeration cycle out from the compressor together with the working fluid can be reduced. The refrigeration oil is not attached to an inner wall of a heat exchanger tube of a heat exchanger, and it is possible to prevent the heat exchanging efficiency from being deteriorated. An amount of refrigeration oil in the oil reservoir 16 can always be maintained constantly, and it is possible to enhance the reliability and efficiency of the compressor.

(Ninth Embodiment)

Fig. 13 is a vertical sectional view of a compressor according to the ninth embodiment of the invention. The compressor according to the eighth embodiment of the present invention has the same structure as that of the compressor of the seventh embodiment as shown in Figs. 10 and 11 except the thin cylinder. The same elements are designated with the same symbols. Explanation of the same structure and effect as those of the seventh embodiment will be omitted.

In the compressor of this embodiment, a thin cylinder 43 as a dividing member is fitted into the coil end 11b on the upper end of the stator 11, and the upper space 19 of the rotational motor is divided by the thin cylinder 43 into the inner space 19a and the outer space 19b. At that time, an upper end of the thin cylinder 43 is brought into contact with the upper end surface 1a in the hermetical container 1 and fixed thereto. A plurality of communication holes 45 are formed in the upper portion of the thin cylinder 43 as flow paths for working fluid which brings the inner space 19a and the outer space 19b into communication with each other. A flange 43a extending inside the thin cylinder 43 from a lower inner side surface of the thin cylinder 43 is provided in the vicinity of the upper surface 12b of the rotor 12. The inner space 19a of the thin cylinder 43 is divided by the flange 43a into an upper space 19a' and a lower space 19c. A flow path 46 which brings the upper space 19a' and the lower space 19c into communication with each other is formed in a center of the flange 43a.

Next, the oil-separating operation of the thin cylinder 43 and the flange 43a and its effect will be explained.

Since the inner space 19a and the outer space 19b divided by the thin cylinder 43 are in communication with each other through the plurality of communication holes 45 formed in the upper portion of the thin cylinder 43, the upper end of the thin cylinder 43 can be brought into contact with the upper end surface 1a in the hermetical container 1 and fixed thereto. Therefore, the positioning precision of the dividing member in the vertical direction when the compressor is assembled is enhanced irrespective of the installation place of the dividing member inside or outside the coil end. If the thin cylinder is provided outside the coil end, the possibility of contact with the thin cylinder and the rotor which rotates at high speed is lowered,

damage caused by contact between the thin cylinder and the rotor is prevented, and a compressor having high reliability can be provided.

The flange 43a extending toward the rotation center axis L is provided on the inner periphery of the thin cylinder 43, the inner space 19a of the thin cylinder 43 is divided by the flange 43a into the upper space 19a' and the lower space 19c, and the flow path 46 for bringing the upper space 19a' and the lower space 19c into communication with each other is formed in the center of the flange 43a. Therefore, in the lower space 19c of the thin cylinder 43, strong centrifugal force acting outwardly from the rotation center axis L is applied to the working fluid which receives the rotational motion energy by viscosity from the upper surface 12b of the rotational rotor 12. The working fluid on which the strong centrifugal force acts flows in the radial direction toward the inner side surface of the thin cylinder 43 through the lower space 19c between the flange 43a and the upper surface 12b of the rotor 12, and flows downwardly through the gap 18 between the rotor 12 and the stator 11 along a corner formed between the flange 43a and the inner side surface of the thin cylinder 43.

At that time, since the working fluid flows outwardly in the vicinity of the rotation center axis L of the upper surface 12b of the rotor 12, the pressure is lowered, and the working fluid flows into the lower space 19c of the flange 43a through the flow path 46 from the upper space 19a' of the flange 43a. Thus, since the thin cylinder 43 is fitted into the coil end 11b and the working fluid is allowed to flow into the inner space 19a of the thin cylinder 43 from the upper portion of the thin cylinder 43, fog drip and liquid drop of the refrigeration oil separated from the working fluid and collected into the lower portion of the upper space 19a' of the flange 43a are forcibly returned into the oil reservoir 16 formed in the bottom of

the hermetical container 1 from the flow path 46 of the flange 43a through the the lower space 19c and the gap 18 between the rotor 12 and the stator 11. Since the fog drip and liquid drop of the refrigeration oil collected into the lower portion of the upper space 19a' of the flange 43a are forcibly returned into the oil reservoir 16 in this manner, it is possible to further prevent the concentration of the oil mist of the upper space 19a' of the flange 43a from being lowered, and to prevent the refrigeration oil from being discharged from the compressor.

Although the flange 43a is formed on the inner periphery of the thin cylinder 43, it is possible to independently provide the flange on the inner periphery of the upper end coil end (this structure is not shown). By the same effect as that of this embodiment, it is possible to forcibly return the fog drip and liquid drop of the refrigeration oil in the vicinity of the flange into the oil reservoir from the lower space formed by the flange.

In addition to the above-described effect, the ninth embodiment can obtain the effect of the seventh and eighth embodiments of course.

As described above, in this embodiment, an amount of the refrigeration oil delivered to the refrigeration cycle out from the compressor together with the working fluid can be reduced. The refrigeration oil is not attached to an inner wall of a heat exchanger tube of a heat exchanger, and it is possible to prevent the heat exchanging efficiency from being deteriorated. An amount of refrigeration oil in the oil reservoir 16 can always be maintained constantly, and it is possible to enhance the reliability and efficiency of the compressor.

In in the compressor of any of the seventh to ninth embodiments, the working fluid in the hermetical container 1 is brought into the supercritical state using working fluid comprising

environment-friendly carbon dioxide, and the meltage of the refrigeration oil with respect to the working fluid is increased. The oil-separating effect is enhanced by effect of the thin cylinder 41 and the like.

(Tenth Embodiment)

Fig. 14 is a vertical sectional view of a compressor according to a tenth embodiment of the invention, Fig. 15 is a lateral sectional view of the compressor shown in Fig. 14 taken along arrows X-X, Fig. 16 is a lateral sectional view of the compressor shown in Fig. 14 taken along arrows Y-Y and Fig. 17 is a lateral sectional view of the compressor shown in Fig. 14 taken along arrows Z-Z. The compressor according to the tenth embodiment of the present invention has almost the same structure as that of the conventional compressor. The same elements are designated with the same symbols.

The compressor of this embodiment comprises the hermetical container 1, the compression mechanism disposed in a lower portion in the hermetical container 1, and the rotational motor disposed in an upper portion in the hermetical container 1. The compression mechanism comprises the shaft 2 capable of rotational around the rotation center axis L, the cylinder 3 having the cylindrical surface 3a therein, the roller 4 fitted over the eccentric portion 2a of the shaft 2 and eccentrically rotational inside the cylinder 3 with the rotation of the shaft 2, the vane 7 which reciprocates within the vane groove 3b of the cylinder 3 while a tip end of the vane 7 being in contact with the roller 4 and which divides a space defined by the cylinder 3 and the roller 4 into the suction chamber 5 and the compression chamber 6, the spring 8 which is disposed on a back surface of the vane 7 and which pushes the vane 7 against the roller 4, and the upper bearing 9 and a lower bearing 10 which support the shaft 2. The upper

bearing 9 includes a flow path 9a which is connected to the suction pipe 15 and which introduces working fluid drawing from the suction pipe 15 into the suction chamber 5, and the discharging hole 9b which discharges working fluid compressed in the compression chamber 6 into the lower space 17 of the rotational motor.

The rotational motor comprises the stator 11 shrinkage fitted into the hermetical container 1, and the rotor 12 which is shrinkage fitted to the shaft 2 and rotates in the inner periphery of the stator 11. The stator 11 is provided at its upper end with the coil end 11b and at its lower end with the coil end 11d. The stator 11 is provided at its outer periphery with a plurality of notches 11a which bring the lower space 17 and the upper space 19 into communication with each other. The notches 11a serve as flow paths for working fluid. Refrigeration oil is reserved in the oil reservoir 16 formed in the bottom of the hermetical container 1.

The hermetical container 1 comprises three elements, i.e., an upper shell 50, a barrel shell 51 and a lower shell 52. The hermetical container 1 is formed by welding. An introducing terminal 54 for energizing the rotational motor in the hermetical container 1 is disposed in the center of the upper shell 50. A columnar cluster 55 is mounted on the introducing terminal 54 in the hermetical container 1 such that a mounting gap is not substantially generated, and the stator 11 of the rotational motor is energized through the lead wire 25. This columnar cluster 55 is provided in the upper central portion of the hermetical container such that a center axis of the cluster 55 substantially coincides with the rotation center axis L of the rotational motor. An outer diameter of the cluster 55 is smaller than an inner diameter of the coil end 11b on the upper end of the stator 11.

A discharge pipe 53 is provided on a side surface of an upper portion of the hermetical container 1 (upper shell 50) for introducing the working fluid into the refrigeration cycle outside the hermetical container 1 from the upper space 19 in the hermetical container 1. The discharge pipe 53 passes through the hermetical container 1 from a side surface of the upper shell 50. The discharge pipe 53 is formed at a lower position than a lower surface of the cluster 55. A suction port 53a of the discharge pipe 53 as an open end into the hermetical container projects from an inner wall surface of the hermetical container 1.

A carbon dioxide refrigerant which is a natural refrigerant is used as the working fluid. In this embodiment, the through holes 12a (see Fig. 8) of the rotor 12 by the same oil-separating plate method as that of the conventional technique is not provided.

Next, the operation of the compressor having the above-described structure will be explained. The working fluid is introduced from the suction pipe 15 into the suction chamber 5 through the flow path 9a provided in the upper bearing 9. If the rotational motor is energized and the shaft 2 which is integral with the rotor 12 is rotated, the roller 4 eccentrically rotates, the capacities of the suction chamber 5 and the compression chamber 6 are varied. With this, the working fluid is drawn and compressed. When a discharge valve (not shown) of the discharging hole 9b is opened, oil mist which is supplied from the oil reservoir 16 and which lubricated the compression mechanism is mixed into the compressed working fluid, and this mixture is discharged into the lower space 17 of the rotational motor. The working fluid in the lower space 17 passes through notches 11a formed in the outer periphery of the stator 11 as gaps between the rotational motor and the hermetical container 1, and through a gap 18 (air gap) between

the stator 11 and the rotor 12, and flows into the upper space 19 of the rotational motor. The working fluid is separated from the refrigeration oil in the upper space 19, and is discharged from the discharge pipe 14.

This oil-separating operation will be explained. As described above, the working fluid including oil mist discharged from the compression mechanism into the lower space 17 of the rotational motor passes through the notches 11a of the stator 11 and the gap 18 between the stator 11 and the rotor 12, and moves into the upper space 19 of the rotational motor. At that time, since the gap 18 is extremely narrow, the rate of working fluid passing through the notches 11a of the stator 11 becomes extremely large.

The working fluid including the oil mist passing through the notches 11a of the stator 11 flows into the upper space 19 of the rotational motor along a wall surface of the hermetical container 1 (barrel shell 51 and the upper shell 50) and then, the working fluid flows downward toward the inner space of the coil end 11b along a side surface of the cluster 55 disposed in the center of the upper shell 50.

Since the rotor 12 of the rotational motor is rotational at high speed, a shearing force caused by the upper surface 12b of the rotor 12 is applied to the downward flow of the working fluid, and turning flow around the rotation center axis L of the rotor 12 is generated. At that time, since the cluster 55 is columnar in shape which is symmetric with respect to the rotation center axis L, the turning flow around the cluster 55 is further prone to be generated, and the flow velocity of the turning flow is uniformly increased. Therefore, the working fluid and the refrigeration oil are separated by a centrifugal force caused by a difference in density therebetween, the oil mist moves

toward the outer peripheral portion of the turning flow, and attaches to the inner wall surface of the upper shell 50 and becomes oil drop. The oil drop drops downward and is returned into the oil reservoir 16 formed in the bottom of the hermetical container 1.

The working fluid which flowed to the inner space of the coil end 11b on the upper end of the stator 11 and which includes the oil mist turns and flows in the inner space of the coil end 11b, and the oil mist is separated from the working fluid by the centrifugal force, the oil mist attaches to the inner peripheral surface of the coil end 11b and becomes oil drop and drops downward, and the oil drop is returned to the oil reservoir 16 formed in the bottom of the hermetical container 1.

The working fluid from which the oil mist is separated flows around a region close to the center of the turning flow which is away from an inner wall surface of the hermetical container 1. Since the suction port 53a projects from the inner wall surface of the hermetical container 1 and the suction port 53a is inserted into this region in this embodiment, most of refrigeration oil is separated from the working fluid which flowed into the discharge pipe 53 and discharged from the compressor.

Since the discharge pipe 53 is lower than the lower surface of the cluster 55, the flow of the working fluid flowing into the upper space 19 is shut off by the side surface of the cluster 55, and the working fluid does not flow into the suction port 53a of the discharge pipe 53 directly. Further, since the cluster 55 is disposed in the introducing terminal 54 such that a mounting gap is not generated and thus, the working fluid which flowed into the upper space 19 does not pass through the mounting gap between the cluster 55 and the introducing terminal 54. Therefore, the turning flow is not disturbed.

The hermetical container 1 is divided into the upper shell 50, the barrel shell 51 and the lower shell 52. Therefore, the discharge pipe 53 and the introducing terminal 54 can be bonded to the upper shell 50 previously, or the compression mechanism and the rotational motor can be fitted to the barrel shell 51. Therefore, the assembling operation of the compressor is facilitated. The outer diameter of the cluster 55 is set smaller than the inner diameter of the coil end 11b. Therefore, there is effect that a space for flowing is increased, and the turning flow of the inner space of the coil end 11b can easily be developed into turning flow around the cluster 55.

As described above, in this embodiment, an amount of the refrigeration oil delivered to the refrigeration cycle out from the compressor together with the working fluid can be reduced extremely. Therefore, the refrigeration oil is not attached to an inner wall of a heat exchanger tube of a heat exchanger, and it is possible to prevent the heat exchanging efficiency from being deteriorated. An amount of refrigeration oil in the oil reservoir 16 can always be maintained constantly, and it is possible to enhance the reliability and efficiency of the compressor.

To prevent the global warming, it is proposed to employ, as a refrigerant, a carbon dioxide refrigerant which is a natural refrigerant having lower warming coefficient. If the carbon dioxide refrigerant is used as the working fluid, a pressure of the compressed working fluid becomes extremely high, a mixing rate of the refrigeration oil into the working fluid is increased, and it becomes difficult to separate the oil from the working fluid. In this regard, according to this embodiment, since the turning flow around the columnar cluster 55 is accelerated, it is possible to easily separate the working fluid and the oil mist from each other.

In the tenth embodiment, only the cluster 55 and the discharge pipe 53 are changed and oil can easily be separated with slight change. Therefore, there is effect that the compressor can be provided extremely inexpensively.

In the compressor of the tenth embodiment, the radial gap between the cluster 55 and the upper shell 50 of the hermetical container 1 is equal to or smaller than the outer diameter of the cluster 55, the turning flow around the cluster 55 can further be accelerated and thus, the oil-separating efficiency can be enhanced. For example, if the outer diameter of the columnar cluster 55 is 28mm and the inner diameter of the upper shell 50 is about 84mm or less, it is possible to remarkably reduce the amount of refrigeration oil delivered to the refrigeration cycle outside the compressor.

The flow velocity of the turning flow is increased as the inner diameter of the hermetical container 1 is smaller. Thus, the oil-separating effect by the turning flow becomes higher. The oil-separating effect can be enhanced only by forming the cluster 55 into the columnar shape and by allowing the discharge pipe 53 to pass through the side surface of the upper shell 50. Therefore, the tenth embodiment can easily be applied to the compressor with the hermetical container 1 having the outer diameter as extremely small as about 80mm or less.

The discharge pipe 53 passes through the side surface of the upper shell 50 in the compressor of the tenth embodiment. If the height of the upper shell 50 is reduced and the height of the barrel shell 51 is increased, the discharge pipe 53 can pass through the side surface of the barrel shell 51, and the same effect can be obtained also in this structure (not shown).

(Eleventh Embodiment)

A compressor of the eleventh embodiment is the same as the compressor of the tenth embodiment shown in Figs. 14, 15 and 16. A vertical sectional view of the compressor of the eleventh embodiment is the same as that shown in Fig. 14. Fig. 18 is a lateral sectional view of a compressor according to the eleventh embodiment of the invention taken along arrows Z-Z in Fig. 14. The same elements are designated with the same symbols. Explanation of the same structure and effect as those of the tenth embodiment will be omitted.

The eleventh embodiment is the same as the tenth embodiment except a discharge pipe 63, an introducing terminal 64, and a hexagonal columnar cluster 65 mounted on the introducing terminal 64. The hexagonal columnar cluster 65 is mounted on the introducing terminal 64 disposed in the center of the upper shell 50 such that almost no mounting gap is generated, and the stator 11 of the rotational motor is energized through the lead wire 25. The cluster 65 is provided in an upper central portion in the hermetical container 1 such that a center axis of the cluster 65 substantially coincides with the rotation center axis L of the rotational motor. A side surface 65a of the hexagonal columnar cluster 65 is opposed to the notches 11a formed in the stator 11. An outer diameter of the hexagonal columnar cluster 65 is smaller than an inner diameter of the coil end 11b on the upper end of the stator 11.

The discharge pipe 63 pass through a side surface of the upper shell 50 and extends into the hermetical container 1, and the discharge pipe 63 is located lower than a lower surface of the cluster 65. A suction port 63a of the discharge pipe 63 as an open end in the hermetical container projects from an inner wall surface of the hermetical container 1. A hydrocarbon refrigerant which is a natural refrigerant is used as the working fluid.

The oil-separating operation will be explained. The working fluid including oil mist discharged from the compression mechanism into the lower space 17 of the rotational motor passes through the notches 11a of the stator 11 and the gap 18 between the stator 11 and the rotor 12, and moves into the upper space 19 of the rotational motor. At that time, since the gap 18 is extremely narrow, the rate of working fluid passing through the notches 11a of the stator 11 becomes extremely large.

The working fluid including the oil mist passing through the notches 11a of the stator 11 flows into the upper space 19 of the rotational motor along a wall surface of the hermetical container 1 (barrel shell 51 and the upper shell 50). Thereafter, the side surface 65a of the cluster 65 disposed in the central portion of the upper shell 50 becomes an obstruction, and a downward flow toward the inner space of the coil end 11b along the side surface 65a is generated. At that time, the side surface 65a of the cluster 65 is opposed to the flow of the working fluid which flows from the notches 11a of the stator 11 and which includes the oil mist. Since the side surface 65a of the cluster 65 is flat as compared with the tenth embodiment, especially the downward flow having no component in the circumferential direction toward the inner space of the coil end 11b is accelerated. Especially the polygonal side surface becomes an obstruction, and the effect for dropping the oil mist downward as the oil drop is enhanced.

Since the rotor 12 of the rotational motor is rotational at high speed, a shearing force caused by the upper surface 12b of the rotor 12 is applied to the downward flow of the working fluid, and turning flow around the rotation center axis L is generated. At that time, since the cluster 65 is hexagonal columnar in shape which is symmetric with respect to the rotation center axis L, the turning

flow around the cluster 65 is further prone to be generated without being hindered, and the flow velocity of the turning flow is uniformly increased. Therefore, the working fluid and the refrigeration oil are separated by a centrifugal force caused by a difference in density therebetween, the oil mist moves toward the outer peripheral portion of the turning flow, and attaches to the inner wall surface of the upper shell 50 and becomes oil drop. The oil drop drops downward and is returned into the oil reservoir 16 formed in the bottom of the hermetical container 1.

The working fluid which flowed to the inner space of the coil end 11b on the upper end of the stator 11 and which includes the oil mist turns and flows in the inner space of the coil end 11b, and the oil mist is separated from the working fluid by the centrifugal force, the oil mist attaches to the inner peripheral surface of the coil end 11b and becomes oil drop and drops downward, and the oil drop is returned to the oil reservoir 16 formed in the bottom of the hermetical container 1.

The working fluid from which the oil mist is separated flows around a region close to the center of the turning flow which is away from an inner wall surface of the hermetical container 1. Since the suction port 63a projects from the inner wall surface of the hermetical container 1 and the suction port 63a is inserted into this region in this embodiment, most of refrigeration oil is separated from the working fluid which flowed into the discharge pipe 63 and discharged from the compressor.

Since the discharge pipe 63 is lower than the lower surface of the cluster 65, the flow of the working fluid flowing into the upper space 19 is shut off by the side surface of the cluster 65, and the working fluid does not flow into the suction port 63a of the discharge

pipe 63 directly. Further, since the cluster 65 is disposed in the introducing terminal 64 such that a mounting gap is not generated and thus, the working fluid which flowed into the upper space 19 does not pass through the mounting gap between the cluster 65 and the introducing terminal 64. Therefore, the turning flow is not disturbed.

In this embodiment, like the tenth embodiment, the hermetical container 1 is divided into three. Therefore, the discharge pipe 63 and the introducing terminal 64 can be bonded to the upper shell 50 previously, or the compression mechanism and the rotational motor can be fitted to the barrel shell 51. Therefore, the assembling operation of the compressor is facilitated. The outer diameter of the cluster 65 is set smaller than the inner diameter of the coil end 11b. Therefore, there is effect that the inner space of the coil end 11b is increased, and the turning flow of the inner space can easily be developed into turning flow around the cluster 65.

As described above, in this embodiment, an amount of the refrigeration oil delivered to the refrigeration cycle out from the compressor together with the working fluid can be reduced extremely. Therefore, the refrigeration oil is not attached to an inner wall of a heat exchanger tube of a heat exchanger, and it is possible to prevent the heat exchanging efficiency from being deteriorated. An amount of refrigeration oil in the oil reservoir 16 can always be maintained constantly, and it is possible to enhance the reliability and efficiency of the compressor.

To prevent the global warming, it is proposed to employ, as a refrigerant, a hydrocarbon refrigerant which is a natural refrigerant having lower warming coefficient. If the hydrocarbon refrigerant is used as the working fluid, it is necessary to take the combustible nature of the refrigerant into consideration and to reduce the amount

of refrigerant to be charged into the refrigeration cycle for enhancing the safety, and it is required to reduce the compressor in size. According to this embodiment, the oil-separating efficiency can be enhanced only by forming the cluster 65 into the hexagonal columnar shape and by allowing the discharge pipe 63 to pass through the side surface of the upper shell 50. This embodiment can easily be applied to the compressor with the hermetical container 1 having the outer diameter as extremely small as about 80mm or less. Thus, according to this embodiment, even if the compressor is small in size using combustible hydrocarbon refrigerant, it is possible to easily reduce the amount of oil to be discharged.

The amount of oil can easily be reduced only by slightly changing the cluster 65 and the discharge pipe 63 and thus, it is possible to provide an extremely inexpensive compressor.

Although the cluster 65 has the regular hexagonal columnar shape in the eleventh embodiment, any shapes (not shown) other than the regular hexagonal columnar can also be employed, and the same effect can be obtained only if the cluster is symmetric with respect to the center axis of the cluster, and the center axis of the cluster substantially coincides with the rotation center axis L of the rotational motor (i.e., rotor 12).

Industrial Applicability

The compressor of this invention is used for a refrigeration cycle such as a refrigerator-freezer or an air conditioner. Carbon dioxide is preferably used as the working fluid.

CLAIMS

1. A compressor comprising:
 - a container;
 - a compression mechanism disposed in a lower portion of said container;
 - a rotational motor disposed in an upper portion of said container, said rotational motor having a stator and a rotor;
 - a coil end provided on each of upper and lower ends of said stator;
 - a discharge pipe provided on an upper end of said container;
 - an oil reservoir provided in a lower portion of said container;and
 - a gap provided between said rotational motor and said container, said gap being operable to introduce working fluid, which is compressed by said compression mechanism, into an upper space of said container;
 - wherein the working fluid is discharged from said container through said discharge pipe; and
 - wherein said discharge pipe has an open end in said container, the open end being located inside said coil end provided on the upper end of said stator.
2. The compressor according to claim 1, wherein said

discharge pipe has a curved portion in said container.

3. The compressor according to claim 2, wherein said discharge pipe is provided on a side surface of said container.

4. The compressor according to claim 1, wherein the open end of said discharge pipe in said container is disposed to face downstream of a rotational direction of said rotor.

5. The compressor according to claim 1, wherein the open end of said discharge pipe in said container is located in a vicinity of a rotation center axis of said rotor.

6. The compressor according to claim 1, wherein an inner diameter of the open end of said discharge pipe located inside said container is larger than an inner diameter of said discharge pipe located outside of said container.

7. A compressor comprising:

- a container;
- a compression mechanism disposed in a lower portion of said container;
- a rotational motor disposed in an upper portion of said container, said rotational motor having a stator and a rotor;

a coil end provided on each of upper and lower ends of said stator;

a discharge pipe provided on an upper end of said container;

an oil reservoir provided in a lower portion of said container;

and

a gap provided between said rotational motor and said container,

said gap being operable to introduce working fluid, which is compressed

by said compression mechanism, into an upper space of said container;

and

a substantially cylindrical dividing member provided in the upper

space of said container and being operable to divide the upper space

into an inner space and an outer space;

wherein said discharge pipe has an open end in said container,

the open end being located inside said substantially cylindrical

dividing member; and

wherein the working fluid is discharged from said container

through said discharge pipe.

8. The compressor according to claim 7, wherein a gap is provided between an upper end of said dividing member and said container.

9. The compressor according to claim 7, wherein said dividing

member is provided with a communication hole between the inner space and the outer space.

10. The compressor according to claim 7, wherein said dividing member is provided inside said coil end provided on the upper end of said stator.

11. The compressor according to claim 7, wherein said dividing member is provided outside said coil end provided on the upper end of said stator.

12. The compressor according to claim 7, wherein an inner diameter of an upper portion of said dividing member is smaller than an inner diameter of a lower portion of said dividing member.

13. The compressor according to claim 1, wherein an upper portion of said container is domical in shape.

14. A compressor comprising:

a container;

a compression mechanism disposed in a lower portion of said container;

a rotational motor disposed in an upper portion of said container, said rotational motor having a stator and a rotor;

a coil end provided on each of upper and lower ends of said stator;

a discharge pipe provided on an upper end of said container;

an oil reservoir provided in a lower portion of said container;

a gap provided between said rotational motor and said container,

said gap being operable to introduce working fluid, which is compressed by said compression mechanism, into an upper space of said container;

an introduction terminal provided in said container and being operable to supply electricity to said rotational motor; and

a cluster provided in said container and being adapted to connect a lead wire from said rotational motor to said introduction terminal;

wherein said cluster is symmetric with respect to an axis thereof, the axis of said cluster being substantially coincident with a rotation central axis of said rotational motor; and

wherein the working fluid is discharged from said container through said discharge pipe.

15. The compressor according to claim 1, further comprising:

an introduction terminal provided in said container and being operable to supply electricity to said rotational motor; and

a cluster adapted to connect a lead wire from said rotational

motor to said introduction terminal, wherein said cluster is symmetric with respect to a center axis thereof, the center axis being substantially coincident with a rotation center axis of said rotational motor.

16. The compressor according to claim 14, wherein said cluster is columnar in shape.

17. The compressor according to claim 14, wherein said cluster is polygonal columnar in shape.

18. The compressor according to claim 14, wherein an outer diameter of said cluster is smaller than an inner diameter of said coil end.

19. The compressor according to claim 1, wherein carbon dioxide is used as the working fluid.

20. The compressor according to claim 7, wherein an upper portion of said container is domical in shape.

21. The compressor according to claim 7, further comprising:
an introduction terminal provided in said container and being operable to supply electricity to said rotational motor; and

a cluster adapted to connect a lead wire from said rotational motor to said introduction terminal, wherein said cluster is symmetric with respect to a center axis thereof, the center axis being substantially coincident with a rotation center axis of said rotational motor.

22. The compressor according to claim 7, wherein carbon dioxide is used as the working fluid.

23. The compressor according to claim 14, wherein carbon dioxide is used as the working fluid.

Fig. 2

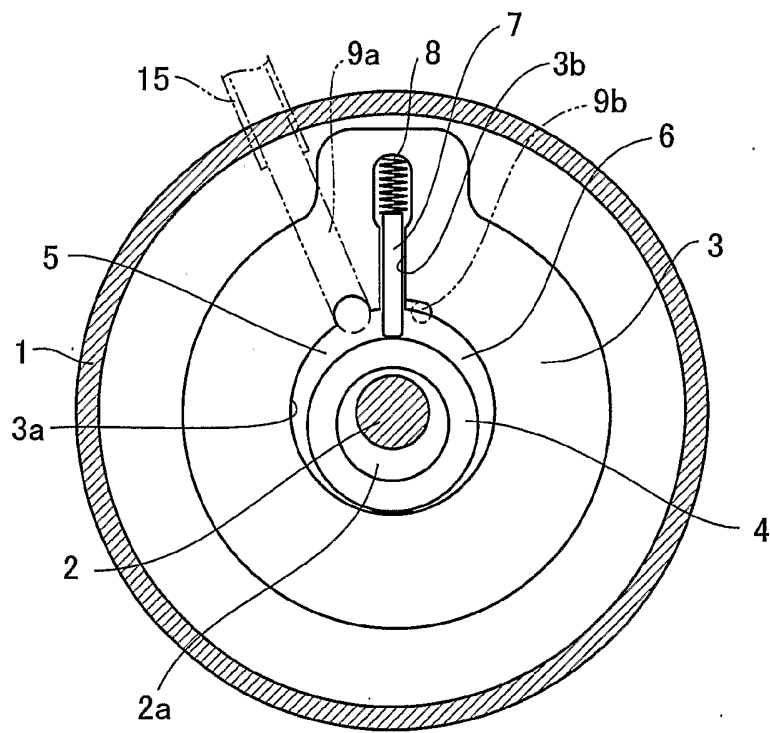

Fig. 3

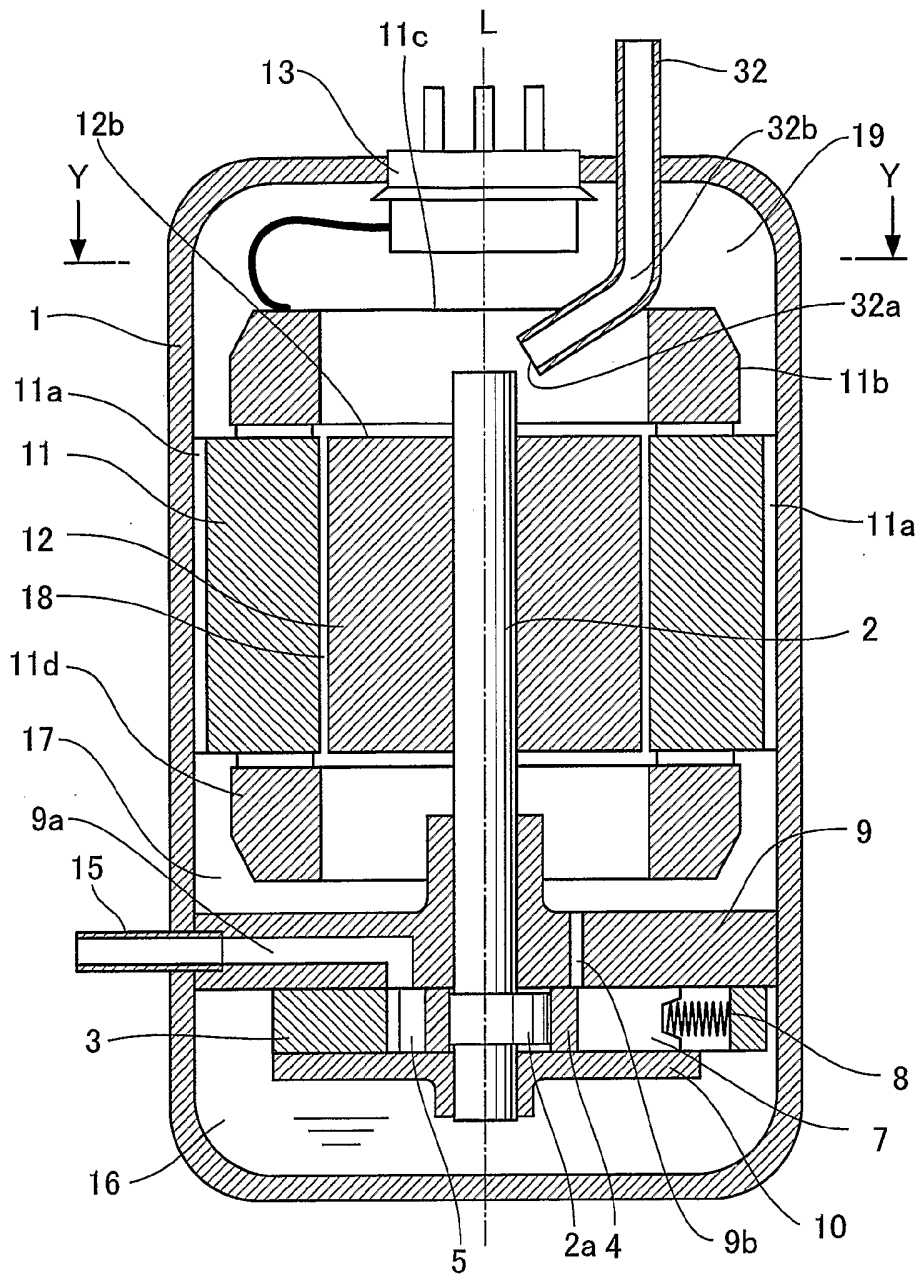

Fig. 4

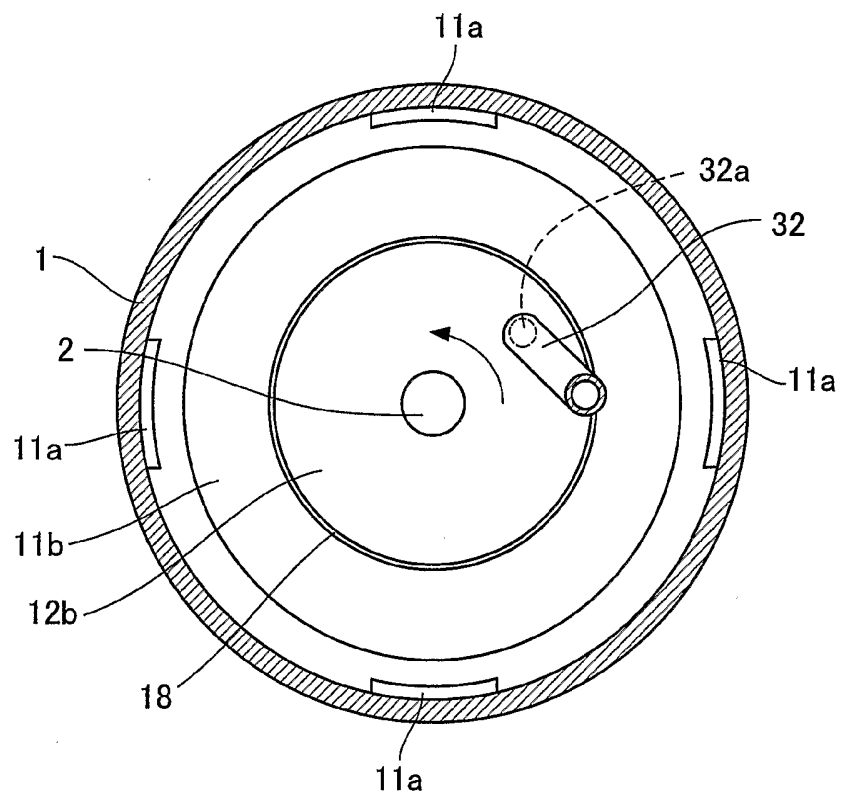

Fig. 5

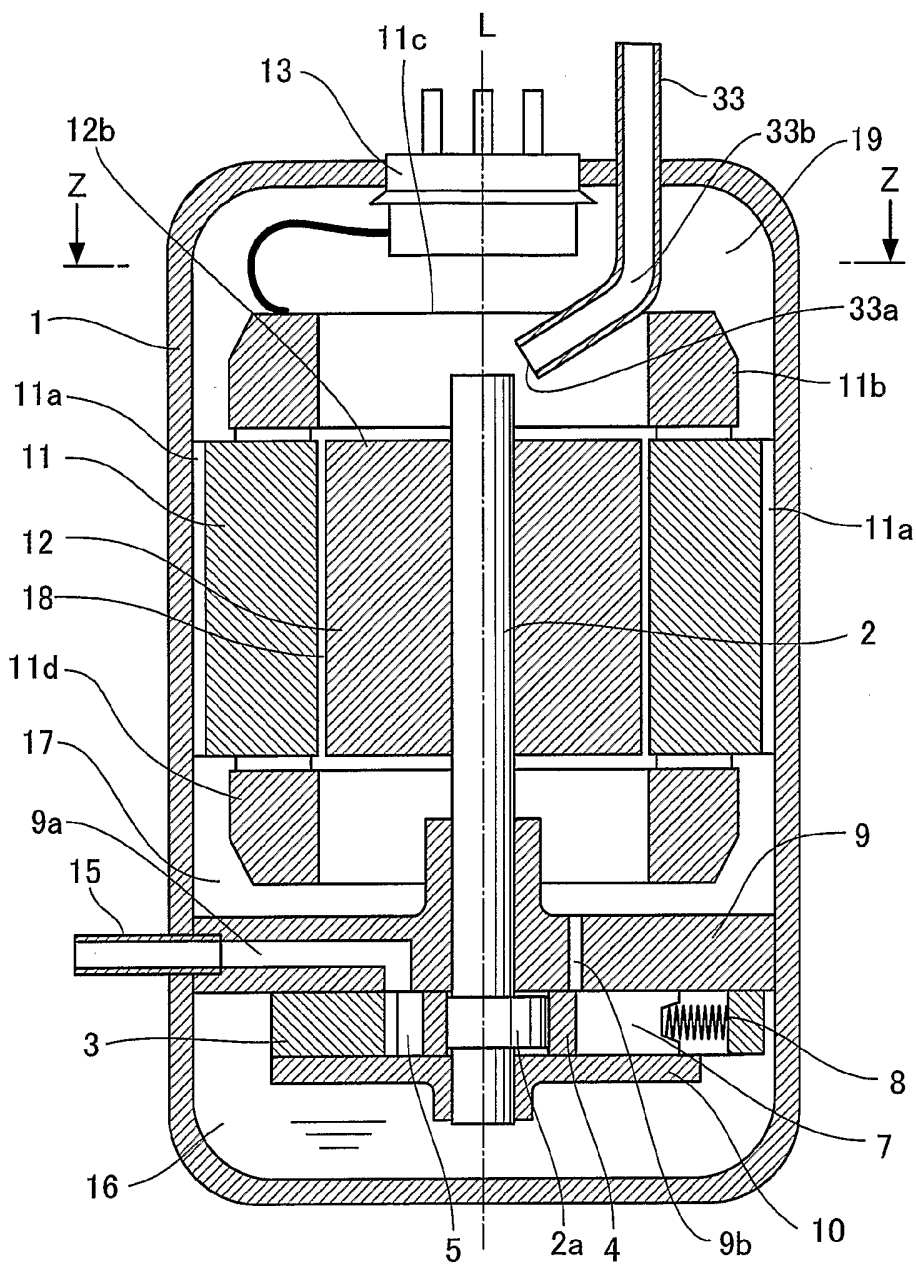

Fig. 6

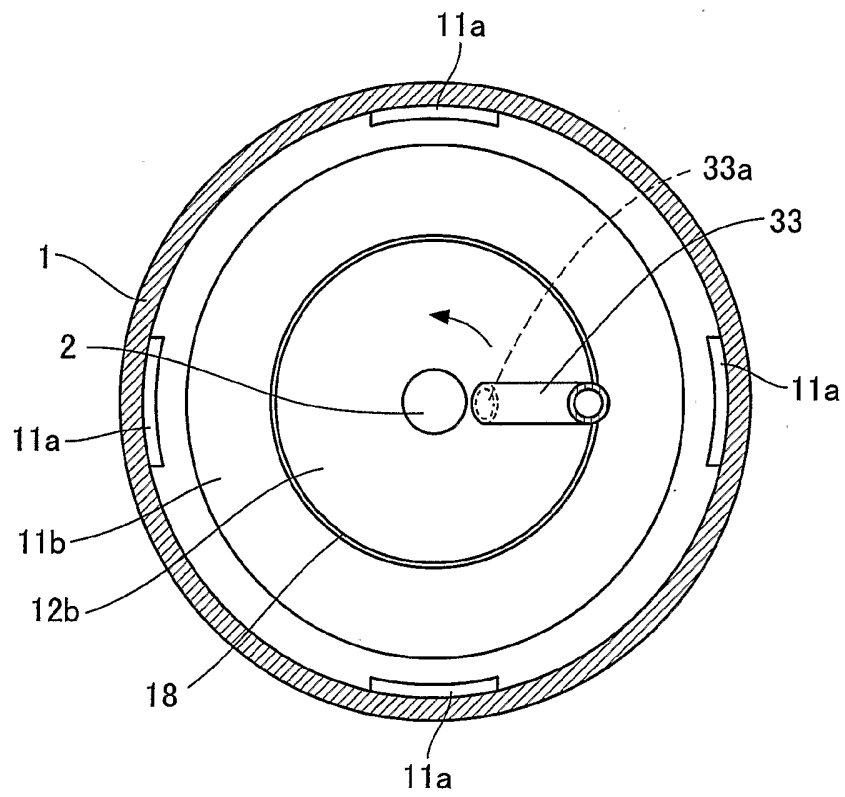

Fig. 7

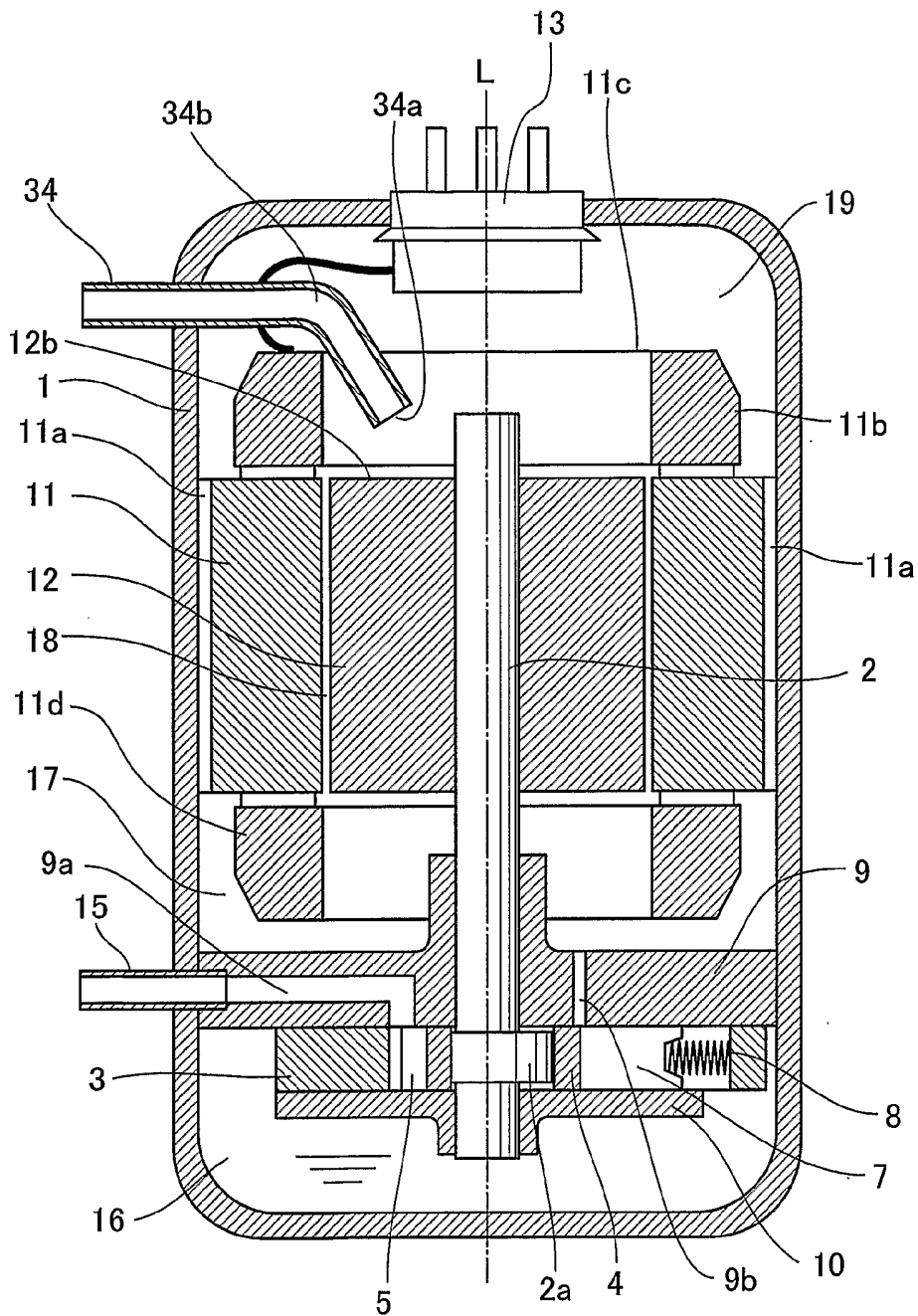

Fig. 8

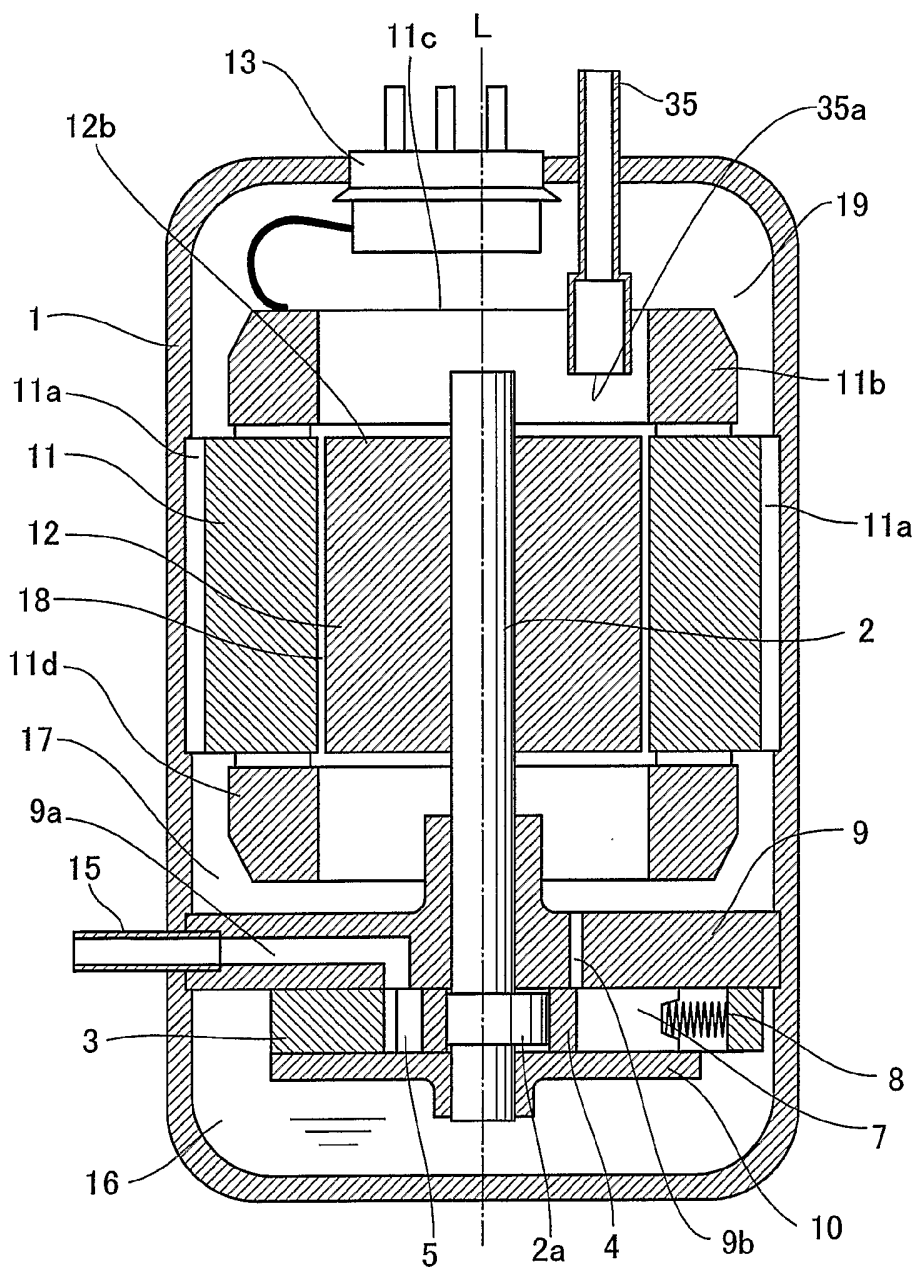

Fig. 9

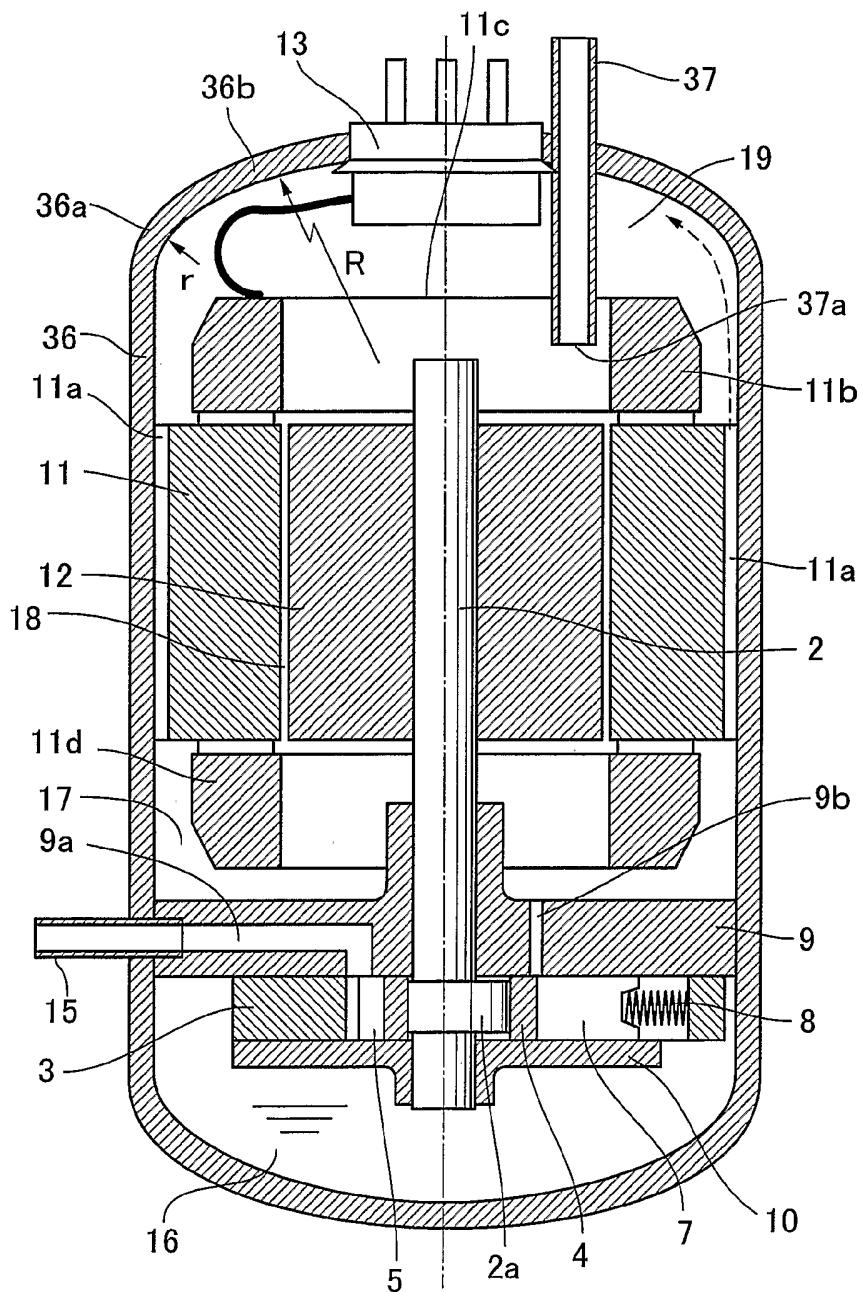

Fig. 11

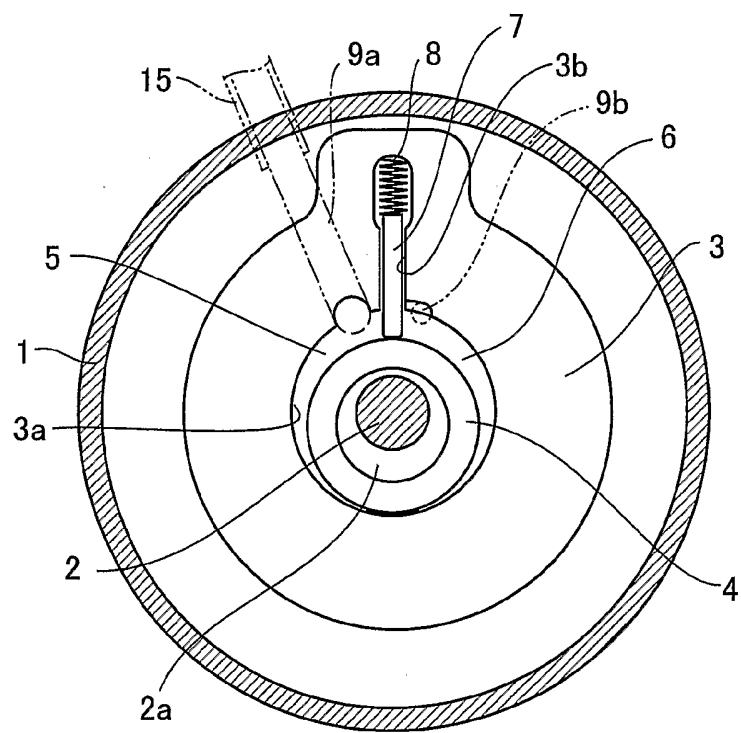

Fig. 12

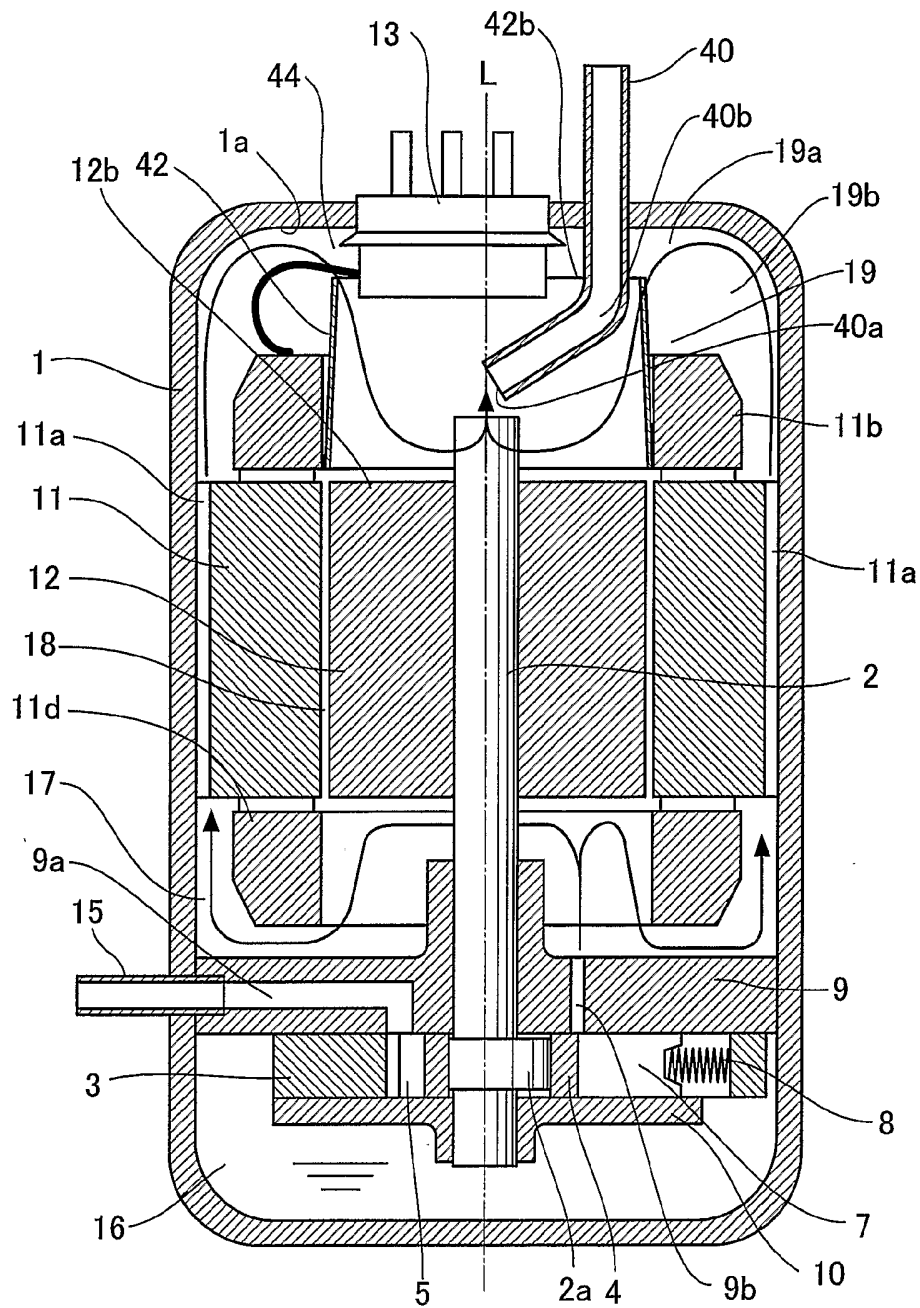

Fig. 13

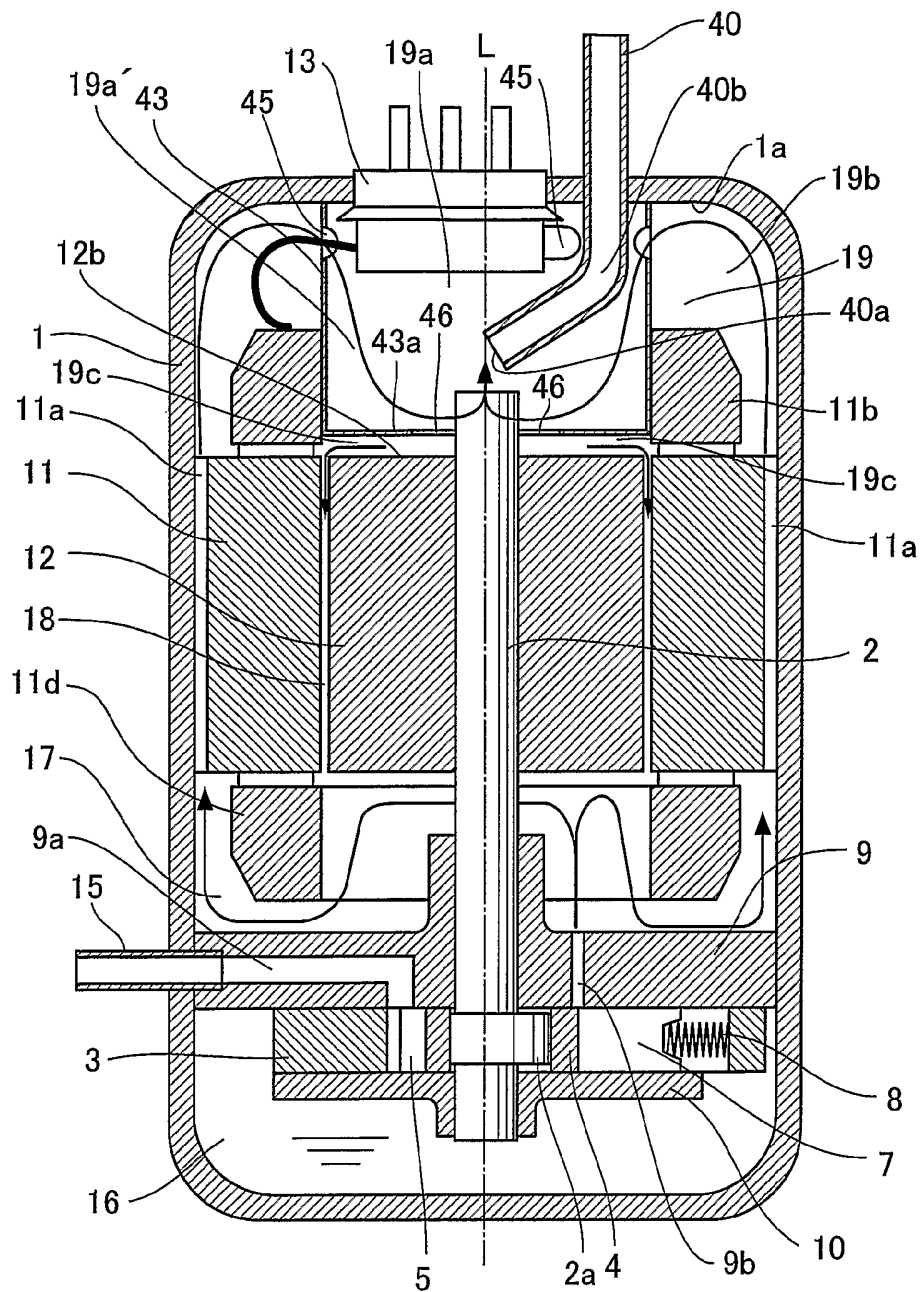

Fig. 15

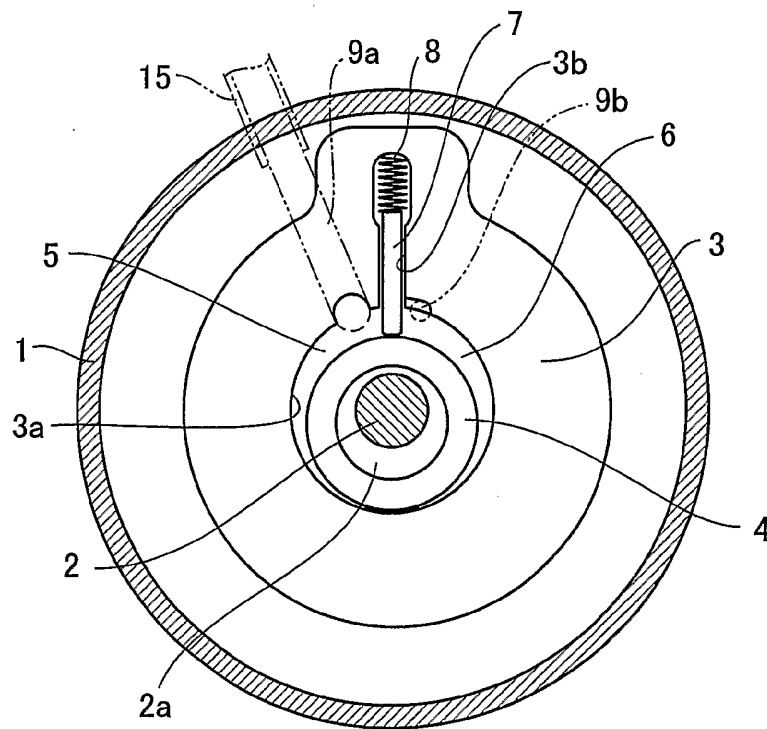

Fig. 16

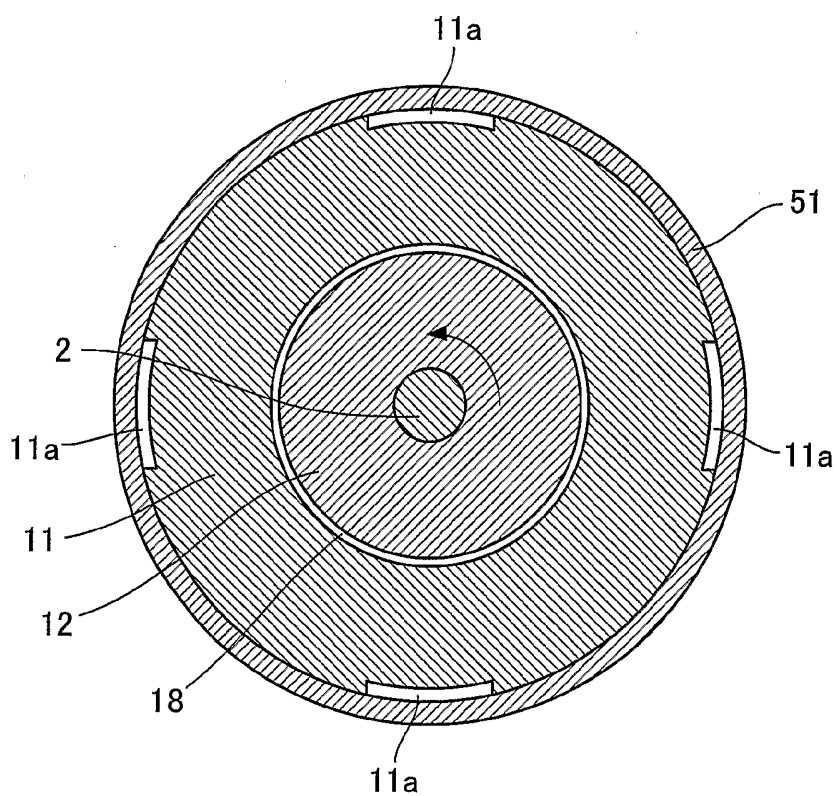

Fig. 17

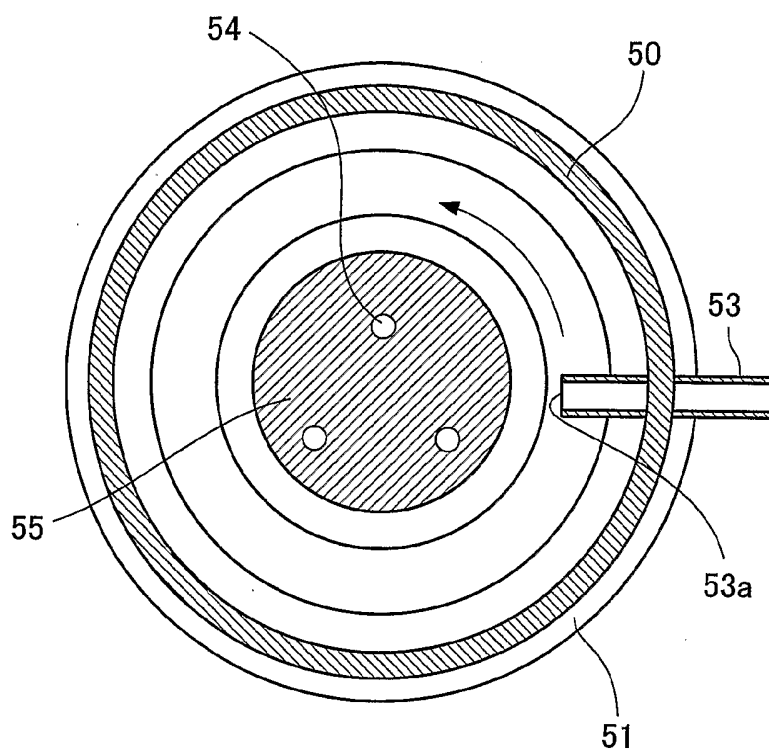

Fig. 18

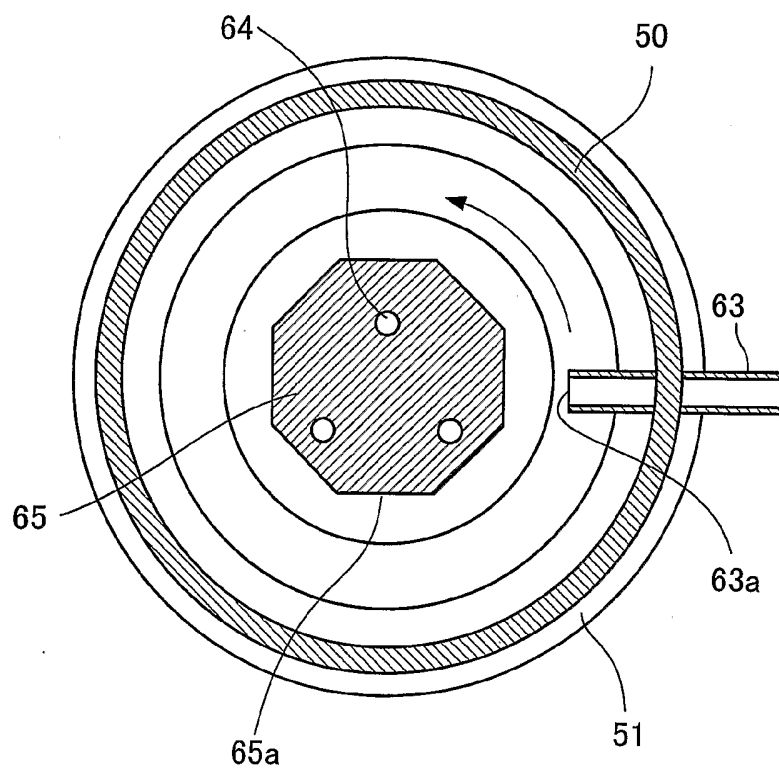

Fig. 19

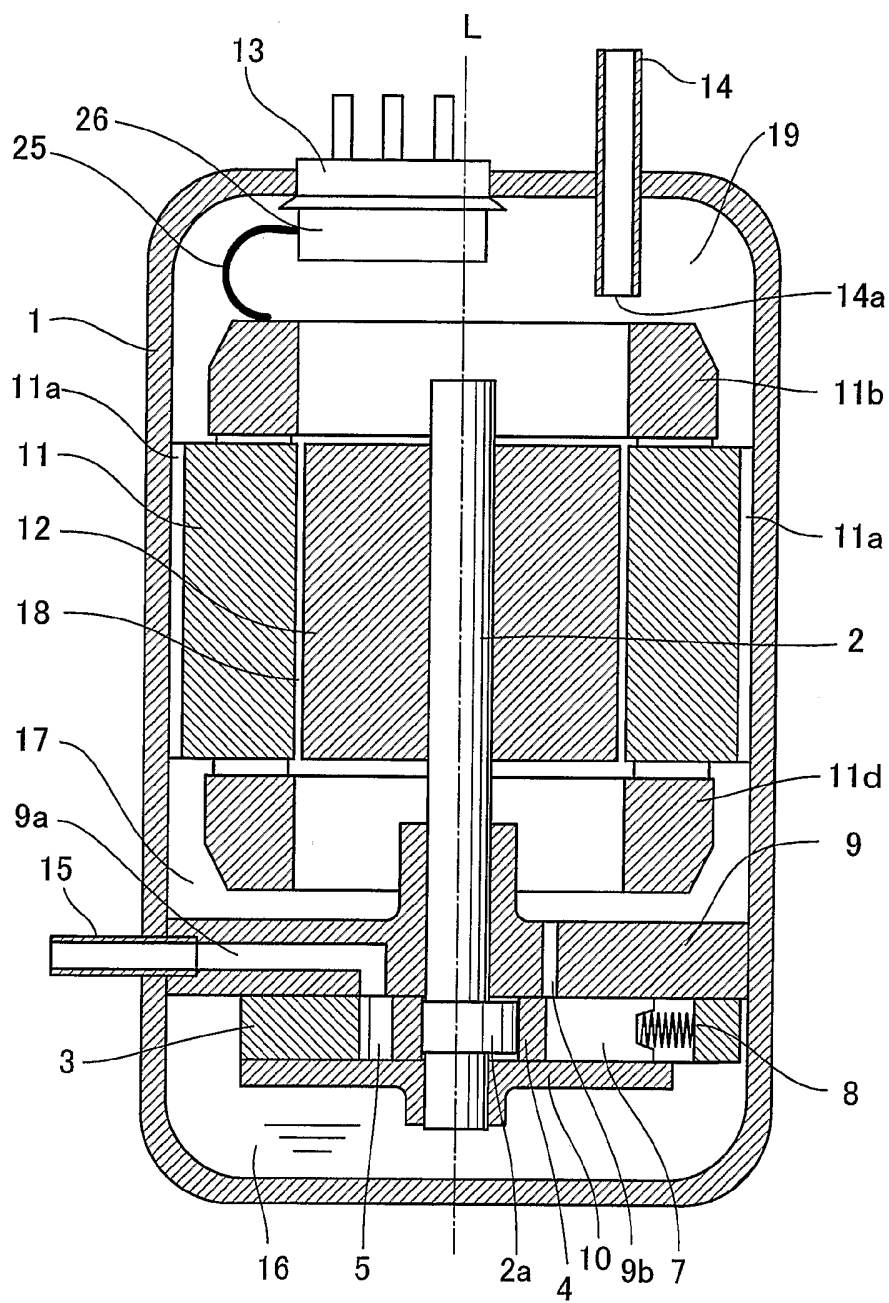

Fig. 20

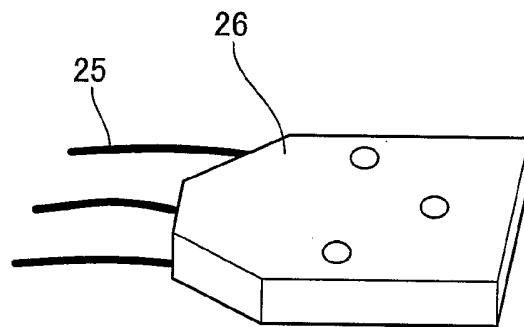
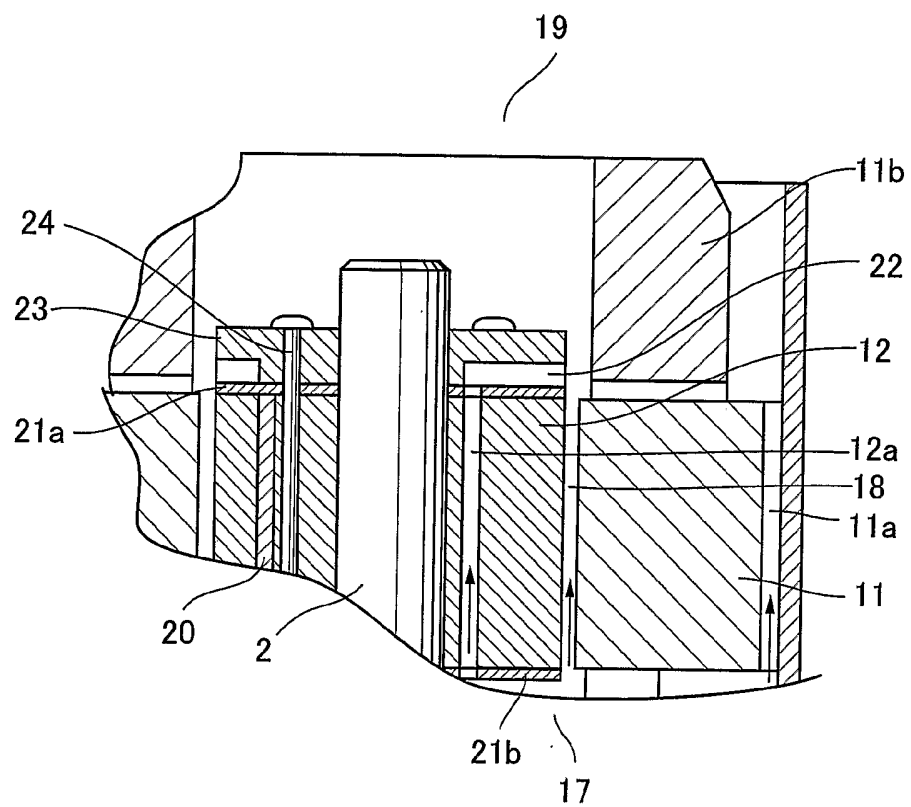

Fig. 21



INTERNATIONAL SEARCH REPORT

International Application No
 PCT/JP2004/007133

A. CLASSIFICATION OF SUBJECT MATTER
 IPC 7 F04C29/02 F04C23/00

According to International Patent Classification (IPC) or to both national classification and IPC

B. FIELDS SEARCHED

Minimum documentation searched (classification system followed by classification symbols)
 IPC 7 F04C

Documentation searched other than minimum documentation to the extent that such documents are included in the fields searched

Electronic data base consulted during the international search (name of data base and, where practical, search terms used)
 EPO-Internal, PAJ

C. DOCUMENTS CONSIDERED TO BE RELEVANT

Category °	Citation of document, with indication, where appropriate, of the relevant passages	Relevant to claim No.
X	US 4 881 879 A (ORTIZ) 21 November 1989 (1989-11-21) column 5, line 28 - line 47; figure 1	1,2
X	US 4 854 831 A (ETEMAD) 8 August 1989 (1989-08-08) column 4, line 41 - column 5, line 22; figures 18-20 column 5, line 49 - column 6, line 9	1,5
X	PATENT ABSTRACTS OF JAPAN vol. 2002, no. 12, 12 December 2002 (2002-12-12) & JP 2002 235666 A (TOSHIBA KYARIA KK), 23 August 2002 (2002-08-23) abstract -/--	1,5,7,8, 10

Further documents are listed in the continuation of box C. Patent family members are listed in annex.

° Special categories of cited documents:

A document defining the general state of the art which is not considered to be of particular relevance	*T* later document published after the international filing date or priority date and not in conflict with the application but cited to understand the principle or theory underlying the invention
E earlier document but published on or after the international filing date	*X* document of particular relevance; the claimed invention cannot be considered novel or cannot be considered to involve an inventive step when the document is taken alone
L document which may throw doubts on priority claim(s) or which is cited to establish the publication date of another citation or other special reason (as specified)	*Y* document of particular relevance; the claimed invention cannot be considered to involve an inventive step when the document is combined with one or more other such documents, such combination being obvious to a person skilled in the art.
O document referring to an oral disclosure, use, exhibition or other means	*&* document member of the same patent family
P document published prior to the international filing date but later than the priority date claimed	

Date of the actual completion of the international search 4 August 2004	Date of mailing of the international search report 06/09/2004
--------------------------------------------------------------------------------	----------------------------------------------------------------------

Name and mailing address of the ISA European Patent Office, P.B. 5818 Patentlaan 2 NL - 2280 HV Rijswijk Tel. (+31-70) 340-2040, Tx. 31 651 epo nl, Fax: (+31-70) 340-3016	Authorized officer Kapoulas, T
----------------------------------------------------------------------------------------------------------------------------------------------------------------------------------------	---------------------------------------

INTERNATIONAL SEARCH REPORT

International Application No
PCT/JP2004/007133

C.(Continuation) DOCUMENTS CONSIDERED TO BE RELEVANT		
Category °	Citation of document, with indication, where appropriate, of the relevant passages	Relevant to claim No.
X	& JP 2002 235666 A (TOSHIBA KYARIA KK) 23 August 2002 (2002-08-23) figure 5 ----- PATENT ABSTRACTS OF JAPAN vol. 0080, no. 09 (M-268), 14 January 1984 (1984-01-14) & JP 58 170893 A (MITSUBISHI DENKI KK), 7 October 1983 (1983-10-07) abstract -----	1,5,7,8
X	----- US 5 597 293 A (BUSHNELL) 28 January 1997 (1997-01-28) column 2, line 65 - column 3, line 38; figures 1,3 -----	1,5,7,9, 10

INTERNATIONAL SEARCH REPORT

Information on patent family members

International Application No
PCT/JP2004/007133

Patent document cited in search report	A	Publication date	Patent family member(s)	Publication date
US 4881879	A	21-11-1989	BR 8806342 A	15-08-1989
			CA 1330976 C	26-07-1994
			DE 3867220 D1	06-02-1992
			EP 0322531 A2	05-07-1989
			JP 1170789 A	05-07-1989
			KR 9108213 B1	11-10-1991
US 4854831	A	08-08-1989	BR 8806206 A	15-08-1989
			CA 1334397 C	14-02-1995
			JP 1155088 A	16-06-1989
			KR 9303543 B1	03-05-1993
			KR 9303545 B1	03-05-1993
JP 2002235666	A	23-08-2002	NONE	
JP 58170893	A	07-10-1983	NONE	
US 5597293	A	28-01-1997	BR 9605915 A	18-08-1998
			CN 1160127 A ,B	24-09-1997
			EG 21123 A	29-11-2000
			ES 2129335 A1	01-06-1999
			IT 1286470 B1	08-07-1998
			JP 2935669 B2	16-08-1999
			JP 9177686 A	11-07-1997
			KR 216719 B1	01-09-1999