

March 2, 1926.

1,574,980

J. LINDBURG

TYPEWRITING MACHINE

Filed March 7, 1924

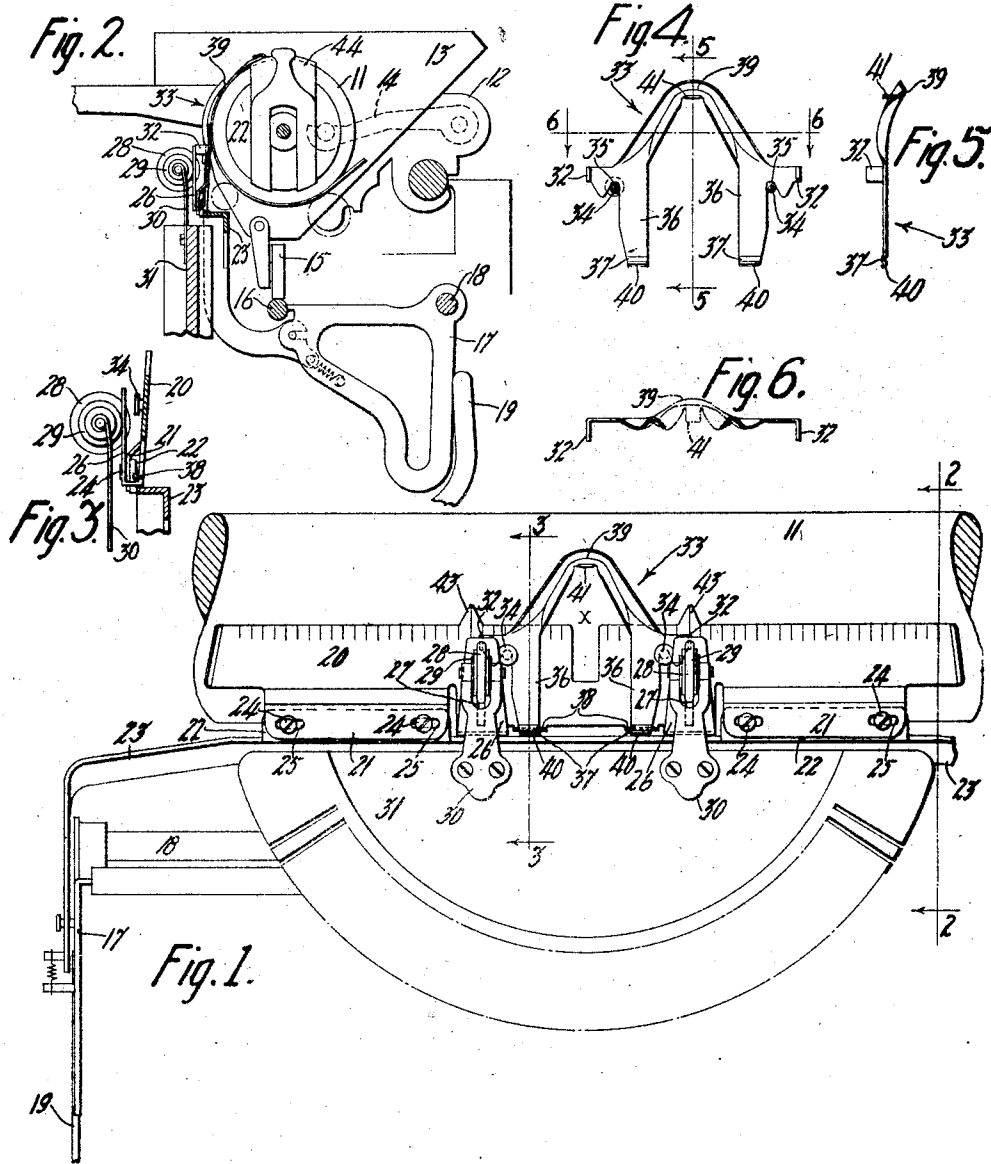

Inventor:
Joseph Lindburg
by D. Stickney
Attorney

UNITED STATES PATENT OFFICE.

JOSEPH LINDBURG, OF BROOKLYN, NEW YORK, ASSIGNOR TO UNDERWOOD TYPE-
WRITER COMPANY, OF NEW YORK, N. Y., A CORPORATION OF DELAWARE.

TYPEWRITING MACHINE.

Application filed March 7, 1924. Serial No. 697,477.

To all whom it may concern:

Be it known that I, JOSEPH LINDBURG, a citizen of the United States, residing in Bay Ridge, Brooklyn, in the county of Kings, city and State of New York, have invented certain new and useful Improvements in Typewriting Machines, of which the following is a specification.

This invention relates to improvements in typewriting machines, and particularly to devices for holding cards and work-sheets to the platen.

One of the features of the invention is to provide for certain flexibility in the holder when typing papers, while reducing or eliminating flexibility when typing cards upon the platen.

Another feature of the invention is to reduce or eliminate excessive pressure of the apex of the card-holder upon comparatively stiff cards, thereby preventing said apex from disarranging the card.

Another feature is to mount the card-holding plate or guide directly onto the wing-scale, and to make said plate or guide readily attachable and detachable.

Another feature is to have the wing-scale connected to the wing-scale frame in a way that will permit endwise adjustment or truing of said scale.

There is shown a card-clipping bar mounted upon and extending along the platen and revolving therewith; and a feature of the invention is to allow the platen, with the bar, to be reversely rotated, and to prevent the bar from catching upon the top edge of the wing-scale during the reverse rotation.

Other features and advantages will hereinafter appear.

In the accompanying drawings,

Figure 1 is a front view showing the wing-scale and card-holding plate in position in front of the platen.

Figure 2 is a view, partly in section, on the line 2—2 of Figure 1, showing filler-blocks in position between the wing-scale and the shields, also rollers in front of the shields.

Figure 3 is a detail view, partly in section, on the line 3—3 of Figure 1, showing the wing-scale with one of its shields, which are hereinafter described, and a bearing-roller in engagement therewith, also studs on said scale for engaging the card-holder or guide.

Figure 4 is a front view of the card-holding plate or guide shown in engagement with the studs of the wing-scale, said studs being shown in section.

Figures 5 and 6 are respectively a side view and a plan of the card-holding plate or guide.

The present invention is illustrated as applied to an Underwood standard typewriting machine in which 11 designates a platen shown in Figure 2 as supported on a carriage 12 by means of a platen-frame 13 and arms 14. The platen-frame 13 has thereunder rollers 15, by means of which it rides on the shift-rail 16 of a shift-frame 17, which is shown in Figure 2 as pivoted at 18, and is actuated by rocker-arms 19.

A wing-scale 20 is shown in Figures 1, 2 and 3 as having at the lower edge thereof vertical ears or flanges 21, which are shown as connected to the corresponding vertical flanges 22 of a wing-scale frame 23 by means of screws 24. Horizontal slots 25 in said ears or flanges 21 allow endwise adjustment of the wing-scale 20 if desired.

The main body of the wing-scale 20 is rearwardly inclined towards the platen when in position on said frame 23, and it has thereon, near the printing point of the platen, forwardly-projecting vertical shields 26, which may be formed from metal strips extending from the main body of said scale 20, integral therewith, by bending said strips to a suitable angle until they assume the position shown in Figures 2 and 3.

The shields 26 are then more or less flexible or yielding at their ends which are remote from the bend, due to the elasticity of the material; the connection at the bend of the shields 26 with the main body of the scale 20 is, therefore, hereinafter described as flexible or yielding. This flexibility or

yielding of the shields is advantageous when typing paper on the platen, the reaction by the platen with paper thereon to the pressure of the bearing-rolls transmitted there-
 5 to by the shields 26 and said scale 20 being comparatively small.

The shields 26 have therein runways 27 for circular flanges 28 of bearing-rolls 29 to fit therein, thereby securing said scale
 10 20 against lateral displacement. Said rolls 29 are supported by the usual spring-brackets 30 which are secured to the type-segment 31, as shown in Figure 1.

When typing stiff cards on the platen, the pressure of the rolls 29 on the shields 26 is transmitted to the main body of the wing-scale 20 by vertical filler-blocks 32, which are preferably made in the form of ribs at the sides of a card-holding plate 33, as shown in Figure 2, which ribs are preferably integral with said plate 33 and formed by bending the sides of said plate 33 at the edges thereof forwardly substantially at right angles to the lower part of said
 25 plate 33.

The filler-blocks 32 are preferably beveled or wedge shaped in a plane substantially at right angles to said scale 20 and the lower part of said plate 33, thereby forcing the
 30 shields 26 forwardly and away from said scale 20 when pressing said plate 33 downwardly onto said scale 20, thereby insuring a comparative rigidity of connection between said scale 20 and the upper parts of the
 35 shields 26, and thereby preventing undue deflection of said shields 26 rearwardly under the pressure of the bearing-rolls 29. This rigidity is advantageous because the resistance to bending of a stiff card against the
 40 platen is considerable.

The card-holding plate 33 is thereby also prevented from rattling or shaking in its seat between the front of the wing-scale 20 and the heads of the studs 34, which are
 45 shown in Figures 1, 3 and 4, and serve as supports for the card-holding plate 33, which has thereon notches 35 to fit the studs 34 when said plate 33 is placed between the heads of the studs 34, rearwardly thereof,
 50 and the front of the wing-scale 20. The card-holding plate or guide 33 has thereon legs 36, which are made in one therewith, and are tapered on the outside thereof in the plane of the lower part of said plate
 55 33, as shown in Figures 1 and 4.

To mount the card-holding plate or guide 33 in position, the ends of the legs 36 thereof are inserted between said studs 34 and it is pushed down until said notches 35
 60 catch upon the studs 34.

To prevent the card-holding plate or guide 33 from being dislocated when in operation, it is provided with grooved projections or detents 37 at the lower ends of the legs 36
 65 thereof, to engage forwardly-projecting

ledges 38, which are formed in the lower edge of the main body of the wing-scale 20, substantially at right angles thereto.

When in operation, the reaction of the platen 11 with the card thereon to the pres-
 70 sure of the apex 39 of said card-holding plate 33 will tend to press the detents 37 onto said ledges 38, thereby preventing the dislocation of said plate 33.

To prevent the detents 37 from catching
 75 on the top of said ledges 38 when the card-holding plate 33 is pressed down into position on said scale 20, the detents are provided at the bottom thereof with forwardly-flaring extensions 40 to ride over said ledges
 80 38, thereby slightly deflecting the legs 36 forwardly until the grooves in said detents 37 are brought opposite said ledges 38 when said legs 36 are sprung back rearwardly, forcing said grooved detents 37 into engage-
 85 ment with said ledges 38.

To facilitate the lifting up or pressing down of the card-holding plate 33 when in operation, a hand-hold or finger-piece 41 is provided at the front of the apex 39 of said
 90 plate, as shown in Figures 4, 5 and 6. The finger-piece 41 may also serve as a pointer for the printing position of a type-character to be written.

The upper part of the card-holding plate
 95 33 near the apex 39 thereof is shown in Figures 1 and 4 as of skeleton construction and having the form of an inverted V, the edges of the sides thereof being flared away, thereby rendering said plate 33 rigid at said
 100 upper part, which is curved towards the platen 11.

The area of contact of the apex 39 with cards on the platen is thereby reduced to a
 105 minimum. The apex 39 of said plate 33 is not quite touching the platen 11 in the absence of the card thereon, leaving a clearance therebetween, which is smaller than the thickness of the card, thereby causing said
 110 apex 39 to bear on the card when the latter is typed on the platen, but the pressure of said apex 39 thereupon is by the above provision reduced to a minimum, thereby preventing said apex 39 from disarranging the
 115 card on the platen.

The wing-scale frame 20 is also shown in Figure 1 as having thereon upwardly-extending horns 43 to prevent bar 44, which is used for holding the leading edge of a card to the platen, from catching upon the
 120 top edge of said scale 20 when the platen, with said bar thereon, is being reversely rotated by the operator, as is the practice in typing cards, especially if the card is to be introduced bottom edge first between the
 125 wing-scale and the platen.

Said bar 44 is substantially the same as described in the patent to C. A. Joerissen, No. 858,655, granted July 2, 1907.

Variations may be resorted to within the
 130

scope of the invention, and portions of the improvements may be used without others.

Having thus described my invention, I claim:

5 1. In a typewriting machine, the combination with a platen, of a wing-scale adjacent the front thereof, said scale carrying resilient ears arranged to overlie the scale in spaced relation thereto, and pressure means engaging against said resilient ears and yieldingly pressing the scale toward the platen.

10 2. In a typewriting machine, the combination of a platen, a carriage for supporting the same, a wing-scale frame in front of the platen, and means for interchangeably holding cards and paper to the platen, said means comprising a wing-scale secured to said frame, substantially vertical shields in front of said scale and flexibly connected thereto, the upper parts of the shields with said scale having spaces therebetween, runways in the shields, bearing rolls to fit the runways, thereby securing the scale against lateral displacement, means for pressing the rolls against the shields for holding said scale to cards and paper on the platen, and a card-holding plate detachably mounted on said scale, said plate including filler-blocks to fit said spaces, said filler-blocks to transmit the pressure from the rolls and shields directly to said scale with said plate for holding cards to the platen.

15 3. In a typewriting machine, the combination of a platen, a carriage for supporting the same, a wing-scale frame in front of the platen, and means for interchangeably holding cards and paper to the platen, said means comprising a wing-scale secured to said frame, substantially vertical shields bent up from the wing-scale to stand in front thereof, the shields being spaced from the scale, runways in the shields, bearing rolls to fit the runways, thereby securing said scale against lateral displacement, means for pressing the rolls against the shields for holding the scale to cards and paper on the platen, and a card-holding plate detachably mounted on said scale, said plate including filler-blocks to fit said spaces, whereby to transmit the pressure from the rolls and shields directly to said scale with said plate for holding cards to the platen.

20 4. In a typewriting machine, the combination of a platen, a carriage for supporting the same, a wing-scale frame in front of the platen, and means for interchangeably holding cards and paper to the platen, said means comprising a wing-scale secured to said frame, combined with substantially vertical shields in front of said scale, said shields being formed of strips made in one with said scale and bent to a suitable angle therewith, thereby making flexible connections of the shields with said scale, runways

in the shields, bearing rolls to fit the runways, thereby securing the scale against lateral displacement, and means for pressing the rolls against the shields, thereby holding the scale to the platen.

5 5. In a typewriting machine, the combination of a platen, a carriage for supporting the same, a wing-scale frame in front of the platen, and means for interchangeably holding cards and paper to the platen, said means comprising a wing-scale secured to said frame, substantially vertical shields in front of said scale, runways in the shields, and bearing rolls to fit the runways, thereby securing said scale against lateral displacement, combined with a card-holding plate removably mounted on said scale and means for pressing the rolls against the shields, thereby holding said scale with said plate to cards on the platen.

10 6. In a typewriting machine, the combination of a platen, a carriage for supporting the same, a wing-scale frame in front of the platen, and means for interchangeably holding cards and paper to the platen, said means comprising a wing-scale secured to said frame, substantially vertical shields in front of said scale, runways in the shields, and bearing rolls to fit the runways, thereby securing the scale against lateral displacement, combined with studs on said scale, a card-holding plate having therein notches to engage the studs, thereby removably mounting said plate on said scale, and means for pressing the rolls against the shields, thereby holding said scale with said plate to cards on the platen.

15 7. In a typewriting machine, the combination of a platen, a carriage for supporting the same, a wing-scale frame in front of the platen, and means for interchangeably holding cards and paper to the platen, said means comprising a wing-scale secured to said frame, substantially vertical shields in front of said scale, runways in the shields, bearing rolls to fit the runways, thereby securing the scale against lateral displacement, a card-holding plate, and means for engaging said plate with said scale near the top thereof, combined with forwardly-projecting ledges at the lower edge of said scale, grooved pendants on said plate to engage said ledges, thereby removably mounting said plate on said scale, and means for pressing the rolls against the shields, thereby holding said scale with said plate to cards on the platen.

20 8. In a typewriting machine, the combination of a platen, a carriage for supporting the same, a wing-scale frame in front of the platen, and means for interchangeably holding cards and paper to the platen, said means comprising a wing-scale secured to said frame, substantially vertical shields in front of said scale, runways in the shields,

70

75

80

85

90

95

100

105

110

115

120

125

130

bearing rolls to fit the runways, thereby securing the scale against lateral displacement, and a card-holding plate, combined with means for removably connecting said plate to said scale at points near the top and bottom thereof and means for pressing the rolls against the shields, thereby holding said scale with said plate to cards on the platen.

9. In a typewriting machine, the combination of a platen, a carriage for supporting the same, a wing-scale frame in front of the platen, and means for interchangeably holding cards and paper to the platen, said means comprising a wing-scale secured to the frame, substantially vertical shields in front of said scale, runways in the shields, bearing rolls to fit the runways, thereby securing said scale against lateral displacement, and a card-holding plate removably mounted on said scale, combined with a handhold on said plate and means for pressing the rolls against the shields, thereby holding said scale with said plate to the platen.

10. In a typewriting machine, the combination of a platen, a carriage for supporting the same, a wing-scale frame in front of the platen, and means for interchangeably holding cards and paper to the platen, said means comprising a wing-scale secured to the frame, substantially vertical shields in front of said scale, runways in the shields, bearing rolls to fit the runways, thereby securing the scale against lateral displacement, studs on said scale, and a card-holding plate having therein notches to engage the studs, thereby removably mounting said plate on said scale, combined with legs on said plate, said legs being tapered in the plane of said plate to be inserted between the studs and pressed into position therebetween, thereby rendering secure the mounting of said plate on said scale, and means for pressing the rolls against the shields, thereby holding said scale with said plate to cards on the platen.

11. In a typewriting machine, the combination with a platen, of a wing-scale adjacent the front thereof, said scale having pendent ears bent up to stand in front of the scale, and pressure means engaging said ears, pressing the scale toward the platen.

12. In a typewriting machine, the combination of a platen, a carriage for supporting the same, a wing-scale frame in front of the platen, and means for interchangeably holding cards and paper to the platen, said means comprising a wing-scale secured to said frame, substantially vertical shields in front of said scale, runways in the shields, bearing rolls to fit the runways, thereby securing the scale against lateral displacement, a card-holding plate, means for engaging said plate with said scale near the top thereof, forwardly-projecting ledges at the lower edge of said scale, and grooved pend-

ants on said plate to engage said ledges, thereby removably mounting said plate on said scale, combined with forwardly-flared extensions of said pendants to ride over said ledges when said plate is pushed down into engagement with said scale, and means for pressing the rolls against the shields, thereby holding said scale with said plate to cards on the platen.

13. In a typewriting machine, the combination of a platen, a carriage for supporting the same, a wing-scale frame in front of the platen, and means for interchangeably holding cards and paper to the platen, said means comprising a wing-scale secured to said frame, substantially vertical shields in front of the wing-scale and flexibly connected thereto, the upper parts of the shields with said scale having spaces therebetween, runways in the shields, bearing rolls to fit the runways, thereby securing said scale against lateral displacement, means for pressing the rolls against the shields for holding the scale to cards and paper on the platen, and a card-holding plate detachably mounted on said scale, said plate including filler-blocks to fit said spaces, combined with bevels on said filler-blocks to force the shields forwardly away from said scale, thereby making a rigid connection therebetween, and said filler-blocks to transmit the pressure from the rolls and shields directly to said scale with said plate for holding cards to the platen.

14. In a typewriting machine, the combination of a platen, a carriage for supporting the same, a wing-scale frame in front of the platen, and means for interchangeably holding cards and paper to the platen, said means comprising a wing-scale secured to said frame, substantially vertical shields connected to said scale, runways in the shields, bearing rolls to fit the runways, thereby securing said scale against lateral displacement, means for pressing the rolls against the shields, thereby holding said scale to the platen, a bar on said platen to hold a card thereon, and upwardly-extending horns on the upper edge of said scale, the tips of the horns being slightly spaced from the platen, so that, upon reversely rotating said platen, the bar engages behind the horns and causes the wing-scale to move forward sufficiently to permit the bar to pass.

15. In a typewriting machine, the combination with a revoluble platen, of a wing-scale adjacent the front thereof, said scale including portions bent from the body thereof so as to stand in front of the scale, in spaced relation thereto, a detachable cardholder arranged to be secured to the wing-scale and having spacers for filling in the space between the wing-scale and said bent portions, and pressure means engaging said

bent portions, whereby to press the latter against the spacers and thereby press the wing-scale toward the platen.

16. In a typewriting machine, the combination with a platen, of a wing-scale having bearing members extending upward from the bottom edge of the wing-scale, so as to stand in front of said wing-scale, in spaced relation thereto, a card-holder detachably mounted on the wing-scale and including blocks for filling in the space between said bearing members and the body of the wing-scale, and pendent portions extending downward from the card-holder on both sides of the printing line and adjacent the blocks, said pendent portions including at their free ends means for engaging around the lower portion of the wing-scale, whereby to hold the card-holder against lifting.

17. In a typewriting machine, the combination with a platen, of a wing-scale adjacent the front thereof, including resilient ears arranged, to overlie the wing-scale pressure means engaging said ears, whereby to press the wing-scale toward the platen, and a card-holding bar fixed to the platen, said wing-scale including upwardly-extending horns positioned substantially behind the resilient ears, the tips of the horns being slightly spaced from the platen, whereby, upon reversely turning the platen, the card-holding bar engages behind said horns and pushes the wing-scale forward directly against the action of said pressure means, sufficiently to allow the bar to pass.

18. In a typewriting machine, the combination with a platen, of a wing-scale, means for pressing the wing-scale toward the platen, and a card-holder detachably mounted on said wing-scale, including a finger-piece vertically above the printing line, whereby said card-holder may be grasped for attaching or removing from the scale, and the finger-piece serves as a pointer for indicating the writing position of a type-character to be written.

19. In a typewriting machine, the combination with a platen, of a wing-scale adjacent the front thereof, and including pendent portions bent up to overlie the wing-scale, the bent-up portions being spaced from said wing-scale, a detachable card-holder including spacers for filling in the space between the bent-up portions and the wing-scale, said spacers being wedge-shaped, whereby to facilitate entry, and pressure means engaging the bent-up portions, whereby to transmit pressure through said spacers to the wing-scale.

20. In a typewriting machine, the combination with a revoluble platen shiftable into upper and lower case-positions, and a floating scale-frame movable up and down with the platen, of a card-holder fixed on

the platen, a resilient wing-scale secured at its lower edge to the scale-frame to permit passage of the card-holder as the platen is rotated, spring shields formed on the lower edge of the scale to extend over the face thereof, means for guiding the shields and for pressing them towards the platen, and a bowed-spring card-guide engageable on the face of the wing-scale interjacent the shields.

21. In a typewriting machine, the combination with a revoluble platen shiftable into upper and lower case-positions, and a floating scale-frame movable up and down with the platen, of a card-holder fixed on the platen, a resilient wing-scale secured at its lower edge to the scale-frame to permit passage of the card-holder as the platen is rotated, spring shields formed on the lower edge of the scale to extend over the face thereof, means for guiding the shields and for pressing them towards the platen, a pair of button-headed studs fixed in the face of the scale near its upper edge, a bow-shaped card-guide curved to clear the platen and having pads at its branches disposable on the scale, said pads presenting side and bottom extensions to engage at their junctions with the studs whereby the card-guide is removably held in place on the scale, and means on the ends of the side extensions to make contact with the shields.

22. In a typewriting machine, the combination with a revoluble platen shiftable into upper and lower case-positions, and a floating scale-frame movable up and down with the platen, of a card-holder fixed on the platen, a resilient wing-scale secured at its lower edge to the scale-frame to permit passage of the card-holder as the platen is rotated, spring shields formed on the lower edge of the scale to extend over the face thereof, means for guiding the shields and for pressing them towards the platen, a pair of button-headed studs fixed in the face of the scale near its upper edge, a bow-shaped card-guide curved to clear the platen and having pads at its branches disposable on the scale, said pads presenting side and bottom extensions to engage at their junctions with the studs whereby the card-guide is removably held in place on the scale, and means on the ends of the bottom extensions to engage the lower edge of the scale.

23. In a typewriting machine, the combination with a revoluble platen shiftable into upper and lower case-positions, and a floating scale-frame movable up and down with the platen, of a card-holder fixed on the platen, a resilient wing-scale secured at its lower edge to the scale-frame to permit passage of the card-holder as the platen is rotated, spring shields formed on the lower edge of the scale to extend over the face thereof, means for guiding the shields and

for pressing them towards the platen, a pair of button-headed studs fixed in the face of the scale near its upper edge, a bow-shaped card-guide curved to clear the platen and
5 having pads at its branches disposable on the scale, said pads presenting side and bottom extensions to engage at their junctions with the studs whereby the card-guide is re-
movably held in place on the scale, said side extensions being bent forward to con- 10
tact with the rear surface of the spring shields, and detents formed on the lower edges of the bottom extensions to engage below the lower edge of the scale.

JOSEPH LINDBURG.