



- (51) **International Patent Classification:**
A61B 5/00 (2006.01) A61M 5/00 (2006.01)
- (21) **International Application Number:**
PCT/US2017/019518
- (22) **International Filing Date:**
24 February 2017 (24.02.2017)
- (25) **Filing Language:** English
- (26) **Publication Language:** English
- (30) **Priority Data:**
62/301,462 29 February 2016 (29.02.2016) US
62/303,251 3 March 2016 (03.03.2016) US
- (71) **Applicant: TRUINJECT MEDICAL CORP.** [US/US];
18662 Macarthur Blvd., Suite 104, Irvine, CA 92612 (US).
- (72) **Inventors: FOSTER, Clark, B.;** 18662 Macarthur Blvd.,
Suite 104, Irvine, CA 92612 (US). **RIOS, Gabrielle, A.;**
8662 Macarthur Blvd., Suite 104, Irvine, CA 92612 (US).
- (74) **Agent: ALTMAN, Daniel, E.;** Knobbe Martens Olson &
Bear, LLP, 2040 Main Street, 14th Floor, Irvine, CA
92706 (US).

- (81) **Designated States** (unless otherwise indicated, for every kind of national protection available): AE, AG, AL, AM, AO, AT, AU, AZ, BA, BB, BG, BH, BN, BR, BW, BY, BZ, CA, CH, CL, CN, CO, CR, CU, CZ, DE, DJ, DK, DM, DO, DZ, EC, EE, EG, ES, FI, GB, GD, GE, GH, GM, GT, HN, HR, HU, ID, IL, IN, IR, IS, JP, KE, KG, KH, KN, KP, KR, KW, KZ, LA, LC, LK, LR, LS, LU, LY, MA, MD, ME, MG, MK, MN, MW, MX, MY, MZ, NA, NG, NI, NO, NZ, OM, PA, PE, PG, PH, PL, PT, QA, RO, RS, RU, RW, SA, SC, SD, SE, SG, SK, SL, SM, ST, SV, SY, TH, TJ, TM, TN, TR, TT, TZ, UA, UG, US, UZ, VC, VN, ZA, ZM, ZW.
- (84) **Designated States** (unless otherwise indicated, for every kind of regional protection available): ARIPO (BW, GH, GM, KE, LR, LS, MW, MZ, NA, RW, SD, SL, ST, SZ, TZ, UG, ZM, ZW), Eurasian (AM, AZ, BY, KG, KZ, RU, TJ, TM), European (AL, AT, BE, BG, CH, CY, CZ, DE, DK, EE, ES, FI, FR, GB, GR, HR, HU, IE, IS, IT, LT, LU, LV, MC, MK, MT, NL, NO, PL, PT, RO, RS, SE, SI, SK, SM, TR), OAPI (BF, BJ, CF, CG, CI, CM, GA, GN, GQ, GW, KM, ML, MR, NE, SN, TD, TG).

[Continued on next page]

(54) **Title:** COSMETIC AND THERAPEUTIC INJECTION SAFETY SYSTEMS, METHODS, AND DEVICES

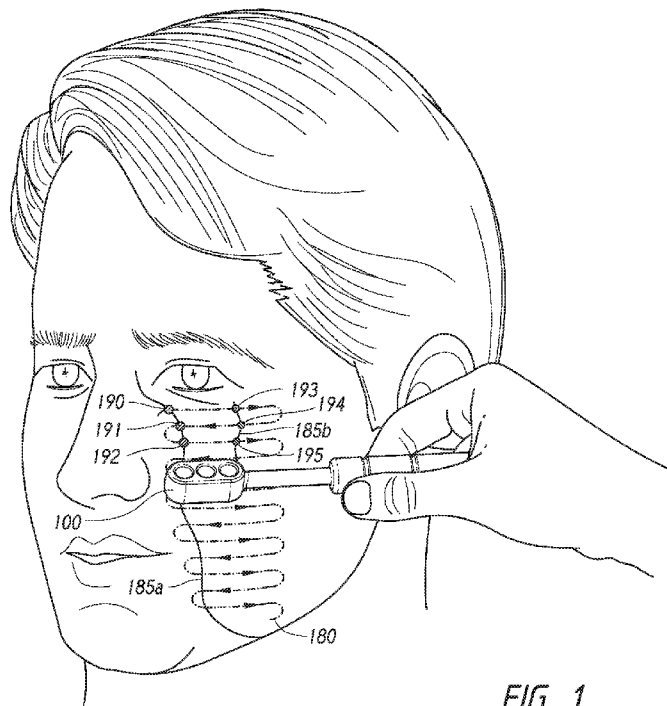

FIG. 1

(57) **Abstract:** An injection scanning printer detects physiological features of a subject prior to injecting. The injection scanning printer provides a visual indication of detected features to improve the injecting process. Safety needles configured to detect nerves, arteries, veins, or other physiological features upon needle placement but prior to injecting are also provided.

WO 2017/151441 A2

Declarations under Rule 4.17:

- *as to applicant's entitlement to apply for and be granted a patent (Rule 4.17(ii))*
- *as to the applicant's entitlement to claim the priority of the earlier application (Rule 4.17(iii))*

Published:

- *without international search report and to be republished upon receipt of that report (Rule 48.2(g))*
- *with information concerning incorporation by reference of missing parts and/or elements (Rule 20.6)*

**COSMETIC AND THERAPEUTIC INJECTION SAFETY
SYSTEMS, METHODS, AND DEVICES**

FIELD OF THE DISCLOSURE

[0001] The present application relates generally to cosmetic and therapeutic injections, and more specifically to systems, devices, and methods for cosmetic and therapeutic injection safety.

The present disclosure relates to a guided medical device that provides an indication of a location of the distal tip of the medical device during use in live tissue.

BACKGROUND

[0002] A variety of medical injection procedures are often performed in prophylactic, curative, therapeutic, or cosmetic treatments. Injections may be administered in various locations on the body, such as under the conjunctiva, into arteries, bone marrow, the spine, the sternum, the pleural space of the chest region, the peritoneal cavity, joint spaces, and internal organs. Injections can also be helpful in administering medication directly into anatomic locations that are generating pain. These injections may be administered intravenously (through the vein), intramuscularly (into the muscle), intradermally (beneath the skin), subcutaneously (into the fatty layer of skin) or intraperitoneal injections (into the body cavity). Injections can be performed on humans as well as animals. The methods of administering injections typically range for different procedures and may depend on the substance being injected, needle size, or area of injection.

[0003] Injections are not limited to treating medical conditions, but may be expanded to treating aesthetic imperfections or restorative cosmetic procedures. Many of these procedures are performed through injections of various products into different parts of the body. The aesthetics and therapeutic industry consists of two main categories of injectable products: neuromodulators and dermal fillers. The neuromodulator industry commonly utilizes nerve-inhibiting products such as Botox[®], Dysport[®], and Xeomin[®]. The dermal filler industry utilizes products administered by providers to patients for both cosmetic and therapeutic reasons, such as, for example, Juvederm[®], Restylane[®],

Belotero[®], Sculptra[®], Artefill[®], and others. These providers or injectors may include plastic surgeons, facial plastic surgeons, oculoplastic surgeons, dermatologists, nurse practitioners, dentists, and nurses.

[0004] Given the variety of injectable products and subjects into which the products will be injected, it is desirable to provide injection safety systems, methods, and devices that reduce error in delivering not only those products available today but also those yet to be deployed.

SUMMARY

[0005] In one innovative aspect, a physiological mapping device is provided. The device includes a sensor configured to detect a physiological feature beneath a skin surface of a subject. The device also includes an information processor configured to receive information from the sensor indicative of the physiological feature and identify the physiological feature based on the received emissions. The device further includes a marking element configured to produce a visible mark on the skin surface identifying the physiological feature based on the received identification.

[0006] In some implementations, the sensor may include one of a piezoelectric sensor, a microphone, an antenna, a gyroscope, or an accelerometer. The physiological feature may include one of a vein, an artery, or a nerve. In some implementations, the information processor is further configured to determine a depth of the identified physiological feature beneath the surface. In such implementations, the marking element is further configured to produce the visible mark to further identify the depth.

[0007] Some devices may include an emitter. In these devices, a detector detects a reflected portion of a signal transmitted by the emitter, and the information processor is configured to identify the physiological feature based on a comparison of the signal transmitted by the emitter and the detected signal.

[0008] The sensor and the marking element may be formed in a head while the information processor may be formed in a base. In such implementations, the head is detachable from the base.

[0009] In a further innovative aspect, a physiological mapping device head is provided. The head includes a sensor configured to detect a physiological feature beneath a surface of a subject. The head also includes a

coupling configured to transmit detected information to an information processor and receive physiological information from the information processor. The head further includes a marking element configured to receive an identification of the physiological feature from an information processor via the coupling and produce a visible mark on the surface identifying the physiological feature based on the received identification.

[0010] In yet another innovative aspect, a physiological mapping device body is provided. The body includes a coupling configured to exchange data with a head that includes a sensor and a marking element. The body includes an information processor which is configured to detect a physiological feature beneath a surface of a subject from the sensor and transmit an identification of the physiological feature to the marking element. The identification includes information causing, in part, the production of a visible mark on the surface identifying the physiological feature.

[0011] A nerve safe needle is provided in yet another innovative aspect. The needle includes a tip formed of an electrically conductive material. The needle also includes a power source coupled with the tip. Upon contact of the tip with a nerve, a circuit is completed with the tip and the power source to deliver a current at the tip. The circuit may be configured to deliver a current sufficient to cause a physiological response.

[0012] An aspirating needle is provided in another innovative aspect. The needle includes a hollow needle tip coupled with a chamber. The chamber includes a first channel to an injectable reservoir and a second channel to an aspirator reservoir. The aspirator reservoir includes an oscillating member configured to oscillate a fluid between the aspirator reservoir to the hollow needle tip. The aspirator reservoir also includes a light source affixed on a wall of the aspirator reservoir and configured to emit light of a predetermined quality. The aspirator reservoir further includes a light detector affixed on the wall of the aspirator reservoir opposite the light source such that a center point of the light source is aligned with a center point of the light detector. The light detector is configured to detect a characteristic of the light emitted from the light source through the fluid in the aspirator reservoir.

[0013] The systems, methods, devices, and computer program products discussed herein each have several aspects, no single one of which is

solely responsible for its desirable attributes. Without limiting the scope of this invention as expressed by the claims which follow, some features are discussed briefly below. After considering this discussion, and particularly after reading the section entitled "Detailed Description," it will be understood how advantageous features of this invention include, among other things, injection safety.

[0014] One of the major problems in the administration of injections is accurate delivery of the injectable to the injection site. Not only is the location important, but also the quantity injected is important for safe and effective use of these substances. Described in further detail below are aspects of systems, methods, and devices for enhancing the safety and effectiveness of injections.

When using a needle-based device, for example a syringe for therapeutic injections, there is a risk of puncturing a blood vessel or hitting a nerve with the needle. Further, it can be difficult to assess that the needle tip is located in correct layer of tissue, which may impact, for example, patient safety, the effectiveness of a blood draw, the performance of an injectable therapeutic. Imaging modalities, such as x-ray, CT, MRI, or the like, can be used prior to a procedure to understand the anatomy surrounding an injection site, these procedures can be expensive, time-consuming, and require analysis. Further, these imaging modalities cannot be used to determine a real-time location of a distal tip of a needle. Thus, there is a need for a medical device that can provide a real-time indication of a location of the distal tip of the needle in living tissue. Such a medical device would enable a clinician to perform the procedure quickly and accurately in an out-patient setting such as a physician's office or even developing areas where the above-described imaging modalities are not available. Further, a guided medical device could be integrated into a robotic system, which could halt movement of the medical device based on the indications provided by the features described herein.

Some aspects of the disclosure are directed toward a system that can determine whether a distal tip of a medical device (e.g., a needle-based device) is in a blood vessel. The medical device can include a sensor for detecting motion, pressure, and/or vibration at the distal tip of the medical device. The sensor can generate a signal based on the detected motion, pressure, and/or vibration. The system can also include a processing unit configured to perform a process that provides an indication of whether the distal tip of the medical device

is in the blood vessel by comparing an aspect (e.g., frequency, amplitude, or otherwise) of the generated signal to a threshold value.

Some aspects of the disclosure are directed toward a system for determining a proximity of a medical device (e.g., a needle-based device) to a nerve. The system can include a pulse generator, a detector, and a processing unit. The pulse generator can be configured to supply an electrical current to a distal tip of the medical device. The detector can be configured to detect a physiological response to the electrical current and generate a signal. The processing unit can be configured to perform a process that provides an indication representative of the proximity of the distal tip of the medical device to a nerve based on the comparison between the generated signal and the threshold value.

Some aspects of the disclosure are directed toward a system for determining a depth of insertion for a medical device (e.g., a needle-based device). The system can include a pulse generator and a vibration sensor. The pulse generator can be configured to supply a pulse (e.g., mechanical or electrical) to a patient's skin at a first time mark. The vibration sensor can be configured to detect a first vibration of the needle in response to the generated pulse at a second time mark. The system can also include a processing unit configured to perform a process that determines a distance between the patient's skin and a distal tip of the needle based on a first time delay between the first time mark and the second time mark. In some implementations, the vibration sensor can be configured to detect a second vibration of the needle at a third time mark. The process can determine a distance between the distal tip of the needle and a bone based on a second time delay between the second time mark and the third time mark.

Some aspects of the disclosure are directed toward an augmented or virtual reality system. The system can include a computing system having at least one processor and a memory device. The computing system can be configured to generate a virtual environment comprising a graphical representation at least one layer of tissue of a patient (e.g., muscles, nerves, bones, and/or vessels). A display device coupled to the computing system can be configured to mesh the virtual environment on the patient, such that a location in the virtual environment is aligned with a same location in the patient.

Any feature, structure, or step disclosed herein can be replaced with or combined with any other feature, structure, or step disclosed herein, or omitted. Further, for purposes of summarizing the disclosure, certain aspects, advantages, and features of the inventions have been described herein. It is to be understood that not necessarily any or all such advantages are achieved in accordance with any particular embodiment of the inventions disclosed herein. No individual aspects of this disclosure are essential or indispensable.

BRIEF DESCRIPTION OF THE DRAWINGS

[0015] FIG. 1 shows an exemplary scanning printer during a mapping session.

[0016] FIG. 2A shows a functional block diagram of an exemplary injection scanning printer.

[0017] FIG. 2B shows an operational diagram of an implementation of an injection scanning printer.

[0018] FIGS. 3A and 3B show illustrations of an example of an injection scanning printer including a head and a base.

[0019] FIG. 4A shows a cross-sectional view of an exemplary nerve detecting needle.

[0020] FIG. 4B shows a functional block diagram of an exemplary nerve detecting needle.

[0021] FIG. 5 shows a cross-sectional view of an exemplary aspirating safety needle.

[0022] FIG. 6 shows a functional block diagram of an exemplary aspirator reservoir.

[0023] FIG. 7 illustrates a process flow diagram of a method of injection mapping.

[0024] FIG. 8 illustrates a process flow diagram of a method of injecting with nerve safety.

[0025] FIG. 9 illustrates a process flow diagram of a method of injection with artery or vein safety.

Figure 1 illustrates a needle-based device positioned in a blood vessel and a needle positioned outside the blood vessel.

Figure 2 illustrates an enlarged view of a hub portion of one of the needle-based devices shown in Figure 1.

Figure 3 illustrates a waveform indicative of motion at a distal tip of each needle shown in Figure 1.

Figure 4 illustrates a system for detecting the proximity of a nerve to a tip of a needle.

Figure 5 is a schematic representation of the system in Figure 4 inserted into the tissue.

Figure 6 illustrates a system for detecting needle depth.

Figure 7 illustrates the system in Figure 6 inserted into live tissue.

Figure 8 illustrates use of a virtual reality system for guiding a syringe.

Figure 9 illustrates an example of a three-dimensional image that can be seen through the virtual reality system.

DETAILED DESCRIPTION

[0026] The present disclosure generally relates to injection safety systems, methods, and devices.

[0027] One feature which provides improved safety is to identify the location of critical physiological features before injecting. For example, some injectables are designed for subcutaneous injection. Delivering such injectables into a physiological feature such as a vein or artery can cause serious side effects. For example, injecting filler into a vein or artery of a human subject may block blood flow thereby killing local tissue or optical nerves. In some extreme cases, these blockages can cause blindness.

[0028] Accordingly, having a "map" of the subject's physiology before injecting would reduce the likelihood of injecting into a critical area. It is important to note that each subject's physiology is different. As such, the location of features may differ from subject to subject. In addition, the proximity of the features to the skin (e.g., depth) may also differ between subjects. To generate the map, the present disclosure provides a device that detects the presence of a physiological feature and provides a visual indication of the feature.

[0029] FIG. 1 shows an exemplary scanning printer during a mapping session. The scanning printer 100 is cast over a portion of a subject via a path 180. In FIG. 1, the subject is a human face. As the scanning printer 100

detects physiological features such as veins or arteries (shown as 185a and 185b), the scanning printer 100 causes the printing of marks 190 through 195 on the surface of the subject. This provides a visible indication of where potentially sensitive features exist to improve the safety of the injection process. The marks may also be different depending on the underlying feature. As shown in FIG. 1, marks 190 through 192 are larger than the marks 193 through 195. The size may be used to indicate different features and/or different depth of the features as described in further detail below. The scanning printer 100 as shown in FIG. 1 is implemented as a facial scanner/printer, included, for example, in a wand or handheld housing. It will be appreciated that the scanning printer 100 may be implemented in a different form factor other than a wand and for scanning surfaces other than a human face.

[0030] FIG. 2A shows a functional block diagram of an exemplary injection scanning printer. The scanning printer 100 includes one or more sensors 102. The sensors 102 are configured to detect emissions from a physiological feature. The sensors 102 may be implemented as a microphone and configured to detect sound emitted from the physiological feature. The sensors 102 may be implemented as an antenna and configured to detect electrical activity from the physiological feature. The sensors 102 may be implemented as an accelerometer and configured to detect motion caused by, for example, pulsing of the physiological feature. The sensors 102 may be configured to detect the information over a period of time thus providing a sampling for an area. The sensors 102 may be implemented as a piezoelectric sensor configured to detect vibrations from the physiological feature. It will be appreciated that in some implementations, multiple sensors may be included in the scanning printer 100 and each sensor may be the same or of a different type. It will be further appreciated that in some implementations, only one sensor may be included in the scanning printer 100.

[0031] The sensor 102 is coupled with an information processor 104. The information processor 104 is configured to receive the information detected by the sensor 102. The information processor 104 may compare the detected information with physiological "signatures" stored in a memory 120. For example, an artery may emit sound at a certain volume and/or frequency. By comparing the received volume or frequency information to previously

determined volume or frequency information for an artery, the information processor 104 may identify the artery.

[0032] The information processor 104 may be configured to determine not just the location of the physiological feature, but also the depth of the feature beneath the surface (e.g., under the skin). The depth may be determined based on the information received from the sensor 102. In some implementations, the frequency may be used to identify the feature while the volume is used to determine the depth.

[0033] In some implementations, the scanning printer 100 may include one or more emitters 125 (shown in FIG. 2A but not shown in FIG. 2B). In such implementations, the sensor 102 may be configured to detect a quantity of an emission after the emitter 125 transmits the emission. The emission and detection may be coordinated by the information processor 104. A comparison of the emitted information to the detected information can be used to determine the location and depth of a physiological feature as described herein.

[0034] The information processor 104, upon identifying a physiological feature, may be configured to transmit a message to a marking element 106. The marking element 106 is configured to provide one or more visible identifiers on the surface of the subject identifying the detected physiological feature. The message may identify the type of mark to make. For example, arteries may be identified with a predetermined symbol or color while veins may be identified with a different symbol or color. The message may identify the size of the mark to make whereby the closer the feature is to the surface of the subject, the larger the mark will be. Of course, other marking systems can be used to provide an indication of depth. The marking element 106 may be an ink marking element. In some implementations, the marking element 106 may be actuated such that an ink containing portion is lowered to contact the surface of the subject to produce the visible mark. In some implementations, the marking element 106 may include a pump configured to spray a marking fluid (e.g., ink) onto the surface of the subject to produce the visible mark.

[0035] In some implementations, the scanning printer 100 may include means for providing the location of the scanning printer 100. For example, the scanning printer 100 may be configured prior to mapping by placing the scanning printer 100 at one or more known features such as corner of an eye,

tip of nose, or other landmark. The means for providing the location of the scanning printer 100 may then be configured to provide a relative location of the scanning printer 100 to the known features. This additional location information may be used by the information processor 104 to further identify the physiological features. The means for providing the location of the scanning printer 100 may include one or more of: an accelerometer, a gyroscope, and a positioning receiver.

[0036] The scanning printer 100 may include a communication interface 135 configured to transmit and receive information. The communication interface 135 may be configured to receive physiological signature data for use by the information processor 104. For example, if a user of the scanning printer 100 is going to inject an animal with a muscle relaxer, the signature data for the animal and injectable substance may be transferred to the scanning printer 100 via the communication interface 135 and stored in the memory 120. Accordingly, the scanning printer 100 can be dynamically reconfigured for detecting a variety of physiological features. The communication interface 135 may be configured for communication via Bluetooth™, Universal Serial Bus, cellular networks, WiFi™ networks, near field communication, or other standardized communication protocol.

[0037] The scanning printer 100 shown in FIG. 2A includes a power source 130. The power source 130 may be a battery, a cord, or other means for powering the scanning printer 100. The elements of the scanning printer 100 are coupled by a bus 140. The bus 140 is configured to allow the elements to exchange data and/or power. In some implementations, parallel busses may be included, one for data and one for power.

[0038] FIG. 2B shows an operational diagram of an implementation of an injection scanning printer. The scanning printer 100 shown in FIG. 2B includes two sensors configured to detect information emitted by the physiological feature, sensor 102a and sensor 102b (collectively and individually hereinafter referred to as "sensors 102"). The sensors 102 are configured in a housing on either side of the marking element 106. The sensors 102 and the marking element 106 are coupled with the information process 104 to allow data communication between the elements.

[0039] The sensors 102 can detect sound waves from physiological

features such as veins or arteries as they travel through the flesh and skin of a subject. While FIG. 2B shows the location of the mapping as a skull, it will be appreciated that the scanning printer 100 may be configured for mapping other parts of the body (e.g., spine, neck, leg, arm, or hand) as well as non-human subjects such as dogs or iguanas.

[0040] In some implementations, the sensor 102 and marking element 106 may be included in a head which can be coupled with a base. FIG. 3A and FIG. 3B show illustrations of an example of an injection scanning printer including a head and a base. FIG. 3A shows the head 302 while FIG. 3B shows the base 304. This configuration allows the head 302 of the scanning printer 100 to be disposed of after a use while the base 304 may be reused. The head 302 may be referred to as a "one time use head" or a "per subject use head." In such implementations, the base 304 may include a power source such as a battery. When the head 302 couples with the base 304, power may be delivered to the marking element 106 and the sensor 102. The coupling also creates a pathway for the information exchanges between the sensor 102 and/or marking element 106 and the information processor 104 described above. In implementations which include an emitter, the emitter may be included in the head 302 as well. In such implementations, additional data and/or power pathways may be included to couple the emitter with the information processor 104 and/or the power source 130 which may be included in the base 304. As shown in FIG. 3A and FIG. 3B, three pins 306 are used to couple the head 302 to the base 304 which includes corresponding ports 312. It will be appreciated that fewer or more pins may be used to couple the head 302 to the base 304. The number of pins may be based in part on the number of pathways (e.g., data and power) needed for the scanning printer 100 configuration.

[0041] The base 304 may include the communication interface 135 (not shown) to transmit and receive information. In some implementations, the communication interface 135 may be located within the base 304 housing. For example, if the communication interface 135 provides wireless communications, the antenna, transceiver, and other elements may be included within the base 304. In some implementations, the communication interface 135 may include a connection port for wired communications such as USB or serial communication. In such implementations, the base 304 may include a port (not shown) configured

to receive a wired connection. As discussed above, the communication interface 135 may be configured to receive physiological signature data for use by the information processor 104. Accordingly, the same base 304 can be reconfigured for detecting a variety of physiological features. Furthermore, the same base 304 may be configured to map using different head configurations. For example, when mapping a leg, it may be desirable to use a head including a single microphone as the sensor. However, when mapping a spine, it may be desirable to use a head which includes multiple sensors of higher sensitivity. Accordingly, the same base 304 may be dynamically reconfigured to process the information detected from a variety of head configurations.

[0042] In some implementations, the base 304 may include a reservoir (not shown). The reservoir may be configured to hold a marking fluid for use by the marking element 106. In such implementations, an additional marking fluid pathway (e.g., duct) may be included to enable delivery of the marking fluid from the base 304 to the marking element 106. In some implementations, the marking fluid may be stored in the head 302.

[0043] The base 304 may, in some implementation, include a light 308 and/or a display 310 configured to provide feedback to a user. For example, the light 308 may illuminate green when a physiological feature is detected. The display 310 may be used for calibrating the location of the scanning printer 100 or providing feedback to the user about the scanning printer 100 usage. For example, the user may be moving the scanning printer 100 too quickly to obtain a reading. In such situations, the information processor 104 may be configured to provide a message for displaying on the display 310 indicating a rescan is needed. The display 310 may be configured to provide feedback regarding the marking fluid level. The display 310 may also be configured to provide feedback regarding the signature data stored in the memory and information port connectivity status. For example, the scanning printer 100 may exchange information via Bluetooth™. Once paired, the display 310 may be configured to display the Bluetooth™ symbol. The display 310 may also be configured to provide an indication of the available power (e.g., battery level) for the scanning printer 100.

[0044] In some implementations, the head 302 and the base 304 may be permanently coupled. In such implementations, it may be desirable to

provide a low cost scanning printer such that the entire device may be disposable. In some implementations, the cost of the sensor or other components may result in a design which is reusable. In such reusable designs, the resources used by the scanning printer (e.g., marking fluid, power) are configured for replenishment. For example, the marking fluid reservoir may be refilled such as via a refill pinhole. Power may be replenished through the use of a rechargeable or swappable battery.

[0045] Another safety innovation relates to the needle. As described above, delivering filler to sensitive areas can have serious consequences. Therefore, configuring the needle to determine what it piercing provides information regarding where the filler will be delivered before actually injecting the filler. For example, the needle tip may be inserted through the skin toward a target area. During placement or once in place, the needle may provide an indication as to whether it is in contact with a nerve. The subject is electrically grounded. The needle may be configured to provide an electrical charge. As configured, if the needle is near a nerve, the electrical charge will cause a physical reaction such as a sensation or twitching. By provoking the body to provide a reaction, the subject and the user of the injector may be alerted to potentially dangerous placement of the needle.

[0046] FIG. 4A shows a cross-sectional view of an exemplary nerve detecting needle. The nerve detecting needle 400 includes a tip 402. The tip 402 is formed of an electrically conductive material such as stainless steel. The tip 402 is connected to a power source 404. An electrically conductive sleeve 403 is separated from the tip 402 by an electrical insulation layer 405. The electrically conductive sleeve 403 may be formed of an electrically conductive material such as stainless steel although the conductive material forming the sleeve 403 need not be the same material as used for the tip 402. The electrical insulation layer 405 may be formed of material which inhibits the flow of electric such as fluoropolymers, rubber-like polymers, or plastics.

[0047] The conductive sleeve 403 is connected to the power source 404. Although not shown, additional components such as transistors or capacitors may be coupled between one or more of the power source 404, the conductive sleeve 403, and the tip 402 to regulate the flow and quantity of power discharged when a nerve is touched. In some implementations, a feedback

element such as an audio alert, a visual alert (e.g., light), or haptic (e.g., vibration) may be included whereby the detection causes activation of the feedback element thus alerting a user to the location of a nerve.

[0048] FIG. 4B shows a functional block diagram of an exemplary nerve detecting needle. The power source 404 is coupled with a first terminal 410. The first terminal 410 is located at the tip 402 of the needle. Separated from the first terminal 410 is a second terminal 420. The second terminal 420 is then coupled with the power source 404 and the conductive sleeve 403. The space between the first terminal 410 and the second terminal 420 creates a nerve detection zone 440. In some implementations, it may be desirable to include a nerve detection zone 440 having a width of 0.5 to 2.0 millimeters between the first terminal 410 and the second terminal 420. When a conductive element enters the nerve detection zone 440, the circuit is completed and a current will flow. The circuit is configured such that the current will cause a physical reaction such as a sensation or twitching in the subject. By provoking the body to provide a reaction, the subject and the user of the injector may be alerted to potentially dangerous placement of the needle. Although not shown, additional components such as transistors or capacitors may be coupled between the power source 404, the first terminal 410, and/or the second terminal 420 to regulate the flow and quantity of power discharged when a nerve is touched.

[0049] A further safety innovation relating to the needle provides detection of an artery or vein based on aspirating blood. The needle may be configured for auto aspiration. A reservoir would be configured such that blood in a vein or artery could be aspirated from the vein or artery through the needle tip into a saline reservoir. A sensor such as an optical detector may be configured to monitor the reservoir. Absent blood in the reservoir, the saline reservoir exhibits a neutral optical spectrum. The sensor may detect a change from neutral to red as blood enters the reservoir. The redness serves as an indication that the needle has pierced a vein or artery. Although discussed in terms of aspiration of blood, the describe features may be applied to provide detection of other intra or extra cellular fluids that may be found in or around an injection site.

[0050] FIG. 5 shows a cross-sectional view of an exemplary aspirating safety needle. The needle 500 includes a tip 502. The tip 502 includes a hollow channel 504 which is coupled with a forward chamber 506.

The forward chamber 506 includes two channels. A first channel 508 leads to a filler reservoir 510. The filler reservoir 510 is configured to hold the injectable filler. A second channel 512 leads to an aspirator reservoir 530. The aspirator reservoir 530 includes fluid reservoir 532. At the base of the fluid reservoir 532 an oscillating member 534 is affixed. The oscillating member 534 is configured with a displacement greater than twice the combined volumes of the hollow channel 504, the forward chamber 506, and the second channel 512. The oscillating member 534 may include a coil 536 and a magnet 538 configured to actuate the oscillating member 534 at a predetermined frequency. In some implementations, the frequency may be between 1 and 5 hertz. The motion of the oscillating member 534 causes the fluid within the fluid reservoir 532 to circulate from the aspirator reservoir 530 through the second channel 512 through the forward chamber 506 and to the tip 502 and back into the aspirator reservoir 530. This allows any blood contacted at the tip 502 to be circulated back into the aspirator reservoir 530. As shown in FIG. 5, a vessel 580 is pierced by the tip 502 which causes a stream of droplets 582 to flow into the aspirator reservoir 530.

[0051] The aspirator reservoir 530 also includes a light source 540. The light source 540 may be a light emitting diode, a bulb, a laser, or other similar emitter. In some implementations, the light source 540 is a white light source. The light source 540 is affixed such that light can shine into the fluid reservoir 532. On an opposite side of the fluid reservoir 532, a light detector 542 is affixed such that a central point of the light detector 542 is aligned with a central point of the light source 540. The light detector 542 is configured to detect the color of the light as it passes through the fluid reservoir 532. The light detector 542 may transmit a message upon detecting light of a predetermined color such as red.

[0052] A power source (not shown) may be included to provide power for the oscillating member, coil, magnet, light source, and light detector. In some implementations, the needle 500 includes a processor (not shown). The processor may be configured to receive messages from the light detector and generate an indication once a color change is detected. The indication may include a sound, a haptic indication (e.g., vibration), a visual indication (e.g., light or display message), or combination thereof.

[0053] It will be appreciated that the needle 500 shown in FIG. 5 may include additional elements. For example needles or syringes typically include a plunger, which has been omitted in FIG. 5 to focus the reader on certain innovative safety aspects. Furthermore, although described as a separate innovative aspect, features of the aspirating safety needle may be combined with the nerve detecting needle 400 (and vice-versa) to provide multiple layers of safety during cosmetic or therapeutic injections.

[0054] FIG. 6 shows a functional block diagram of an exemplary aspirator reservoir. The aspirator reservoir 530 shown in FIG. 6 highlights the interconnectivity of the elements which may be included in an implementation. The aspirator reservoir 530 includes one or more light sources 540. In implementations including multiple light sources, it may be desirable to affix the light sources 540 in a pattern opposite the light detector 542 to maximize the illumination of the reservoir fluid. The aspirator reservoir 530 may include one or more light detectors 542. In implementations where multiple light detectors are included, it may be desirable to arrange the detectors in a pattern to ensure sensing over a maximized area of reservoir fluid. In some implementations, where the number of sensors is equal to the number of detectors, it may be desirable to pair a sensor with a detector and align the centers of each. The light sources may be the same type of light (e.g., white) or have different characteristics. In such implementations, it may be desirable to create detection zones for each light type using different sensors.

[0055] An aspiration processor 546 may be configured to control the oscillating member 534, the light source 540, and the light detector 542. For example, it may be desirable to coordinate the cycle of oscillation, illumination, and detection so as to conserve power. In such implementations, a period of illumination may occur after an oscillation followed by a moment of detection. The aspiration processor 546 may also be configured to determine when a characteristic of the light detected indicates the presence of blood or other identifiable fluid. A memory 548 may be configured to store the light characteristics and response messages associated with detection thereof. The aspiration processor 546 compares the detected information with the stored characteristics to determine whether an identified fluid has been introduced into the aspirator reservoir 530. A communication interface 555 may be included to

transmit and receive information to and from the aspirator reservoir 530. For example, upon detecting the introduction of a fluid into the reservoir, the communication interface 555 may transmit a message indicating the presence of a fluid. This may include an audio sound, a visual message, or a data message via a communication protocol such as Bluetooth™, near field communication, or other wireless protocol. The communication interface 555 may also be configured to receive characteristic information for identifiable fluids. The characteristics may be stored in the memory 548 for use by the aspiration processor 546. The communication interface 555 may receive operational parameters for the aspirating reservoir 530 such as an oscillation rate, lighting patterns, and detection patterns. The operational parameters may be stored in the memory 548 and used by the aspiration processor 546 in coordinating the functions of the aspirating reservoir 530 described above.

[0056] A power source 550 may be included to provide power for the elements of the aspirating reservoir 530. It may be desirable to include a small form factor power source due to the precision size of the needle. In such implementations, the power source 550 may be a coin cell. The elements of the aspirating reservoir 530 shown in FIG. 6 are coupled by a bus 560. The bus 560 is configured to allow the elements to exchange data and/or power. In some implementations, parallel busses may be included, such as one bus for data and one bus for power.

[0057] FIG. 7 illustrates a process flow diagram of a method of injection mapping. The method of injection mapping shown in FIG. 7 may be implemented in part by the scanning printer 100 described above.

[0058] The method begins at determination block 702 where a determination is made as to whether the device is ready to map. The determination may be based on sensor information. In some implementations, the scanning printer may include a contact detector which determined whether the wand is in contact with a surface (e.g., skin). If the determination at block 702 is negative, at block 704, a not ready message is provided. For example, a display may be provided a message identifying the scanning printer is not ready for mapping.

[0059] Returning to block 702, if the determination is made that the device is ready for mapping, at block 706, an emission is detected. The emission

may be, for example, a sound wave from a physiological feature located beneath the surface being mapped. At block 708, the detected emission is transmitted from the sensor to the information processor. At block 710, the information processor obtains the candidate physiological features such as from a memory. The candidate features includes emission signatures for each feature. At decision block 712, a determination is made as to whether the received emission matches any of the emissions signatures. If not, the process returns to block 706 to continue detection. If a match is found, at block 714, the information processor may optionally determine the depth of the feature. The depth determination may be based on the received emission and the emission signature information. At block 716, a marking message is generated based on the matched feature and, if available, depth. At block 718, the marking message is transmitted to the marking element. At block 720, the marking element produces a visible mark based on the marking message on the surface of the subject. The visible mark identifies at least the location of a physiological feature. In some implementations, different marks may be made to identify the type of feature. In some implementations, the marks may be varied to indicate the relative depth of the feature. Once marked, the process may return to block 706 to continue detecting additional emissions and provide further mapping.

[0060] FIG. 8 illustrates a process flow diagram of a method of injecting with nerve safety. The method may be implemented in part by the nerve detecting needle 400 described above. At block 802, the needle tip is positioned in the subject. At block 804, the subject is observed. In some implementations, the observation may be visual. In some implementations, a motion detector may be included to observe a response by the subject to the current needle position. At decision block 806, it is determined whether a response is observed. The response may be a twitching of the subject or a sensation (e.g., pain or heat) by the subject. If a response is observed, at block 808 feedback is generated. The feedback alerts the needle operator that a nerve may be contacted. Based on this feedback, the process may return to block 802 for further needle positioning. If a response is not observed at block 806, the process continues to determination block 810. At block 810, a determination is made as to whether the needle is in its final position. A final position generally refers to the position at which the injectable substance will be delivered. If it is determined at block 810

that the needle is not in its final position, the process returns to block 802 for further needle positioning. If it is determined at block 810 that the needle is in its final position, at block 812 the injectable substance is delivered.

[0061] FIG. 9 illustrates a process flow diagram of a method of injection with artery or vein safety. The method may be implemented in part by the aspirating safety needle 500 described above. At block 902, the needle tip is positioned in the subject. At block 904, fluid is oscillated or otherwise circulated between the needle tip and the aspirating reservoir. At block 906, light is emitted into the aspirating reservoir. At block 908, the emitted light is detected. The detection includes detecting a change in a characteristic of the light indicating the mixing of blood or other fluid with the reservoir fluid. At decision block 910, a determination is made as to whether the detected characteristic of the light indicates mixing of the aspirator reservoir fluid with a fluid of interest such as blood. For example, the aspirator reservoir fluid may be saline and provide a first set of light characteristics (e.g., color, intensity). If blood is mixed with the aspirator reservoir fluid, the light characteristics detected will change. Based on the light characteristics detected and/or the change, mixing may be identified. If mixing is identified, at block 912 feedback is generated. The feedback alerts the needle operator that a vein or artery may be contacted. Based on this feedback, the process may return to block 902 for further needle positioning. If fluid mixing is not detected at block 910, the process continues to determination block 914. At block 914, a determination is made as to whether the needle is in its final position. A final position generally refers to the position at which the injectable substance will be delivered. If it is determined at block 914 that the needle is not in its final position, the process returns to block 902 for further needle positioning. If it is determined at block 914 that the needle is in its final position, at block 916 the injectable substance is delivered.

[0062] The word "exemplary" is used herein to mean "serving as an example, instance, or illustration." Any embodiment described herein as "exemplary" is not necessarily to be construed as preferred or advantageous over other embodiments. Various aspects of the novel systems, apparatuses, and methods are described more fully hereinafter with reference to the accompanying drawings. This disclosure may, however, be embodied in many different forms and should not be construed as limited to any specific structure

or function presented throughout this disclosure. Rather, these aspects are provided so that this disclosure will be thorough and complete, and will fully convey the scope of the disclosure to those skilled in the art. Based on the teachings herein, one skilled in the art may appreciate that the scope of the disclosure is intended to cover any aspect of the novel systems, apparatuses, and methods disclosed herein, whether implemented independently of, or combined with, any other aspect described. For example, an apparatus may be implemented or a method may be practiced using any number of the aspects set forth herein. In addition, the scope of the described features is intended to cover such an apparatus or method which is practiced using other structure, functionality, or structure and functionality in addition to or other than the various aspects of the invention set forth herein. It may be understood that any aspect disclosed herein may be embodied by one or more elements of a claim.

[0063] Although particular aspects are described herein, many variations and permutations of these aspects fall within the scope of the disclosure. Although some benefits and advantages of the preferred aspects are mentioned, the scope of the disclosure is not limited to particular benefits, uses, or objectives. Rather, aspects of the disclosure are broadly applicable to different injection training technologies, system configurations, networks, and transmission protocols, some of which are illustrated by way of example in the figures and the included description of the preferred aspects. The detailed description and drawings are merely illustrative of the disclosure rather than limiting, the scope of the disclosure being defined by the appended claims and equivalents thereof.

[0064] The terms “processor” and “processor module,” as used herein are a broad terms, and are to be given their ordinary and customary meaning to a person of ordinary skill in the art (and are not to be limited to a special or customized meaning), and refer without limitation to a computer system, state machine, processor, or the like designed to perform arithmetic or logic operations using logic circuitry that responds to and processes the basic instructions that drive a computer. In some embodiments, the terms can include ROM and/or RAM associated therewith.

[0065] As used herein, the term “determining” encompasses a wide variety of actions. For example, “determining” may include calculating,

computing, processing, deriving, investigating, looking up (e.g., looking up in a table, a database or another data structure), ascertaining and the like. Also, "determining" may include receiving (e.g., receiving information), accessing (e.g., accessing data in a memory) and the like. Also, "determining" may include resolving, selecting, choosing, establishing, and the like.

[0066] As used herein, the term "message" encompasses a wide variety of formats for transmitting information. A message may include a machine readable aggregation of information such as an XML document, fixed field message, comma separated message, or the like. A message may, in some implementations, include a signal utilized to transmit one or more representations of the information. While recited in the singular, it will be understood that a message may be composed/transmitted/stored/received/etc. in multiple parts.

[0067] Any reference to an element herein using a designation such as "first," "second," and so forth does not generally limit the quantity or order of those elements. Rather, these designations may be used herein as a convenient method of distinguishing between two or more elements or instances of an element. Thus, a reference to first and second elements does not mean that only two elements may be employed there or that the first element must precede the second element in some manner. Also, unless stated otherwise a set of elements may include one or more elements.

[0068] Conditional language used herein, such as, among others, "can," "could," "might," "may," "e.g.," and the like, unless specifically stated otherwise, or otherwise understood within the context as used, is generally intended to convey that certain embodiments include, while other embodiments do not include, certain features, elements and/or states. Thus, such conditional language is not generally intended to imply that features, elements and/or states are in any way required for one or more embodiments or that one or more embodiments necessarily include logic for deciding, with or without author input or prompting, whether these features, elements and/or states are included or are to be performed in any particular embodiment.

[0069] Depending on the embodiment, certain acts, events, or functions of any of the methods described herein can be performed in a different sequence, can be added, merged, or left out altogether (e.g., not all described acts or events are necessary for the practice of the method). Moreover, in certain

embodiments, acts or events can be performed concurrently, e.g., through multi-threaded processing, interrupt processing, or multiple processors or processor cores, rather than sequentially.

[0070] The various illustrative logical blocks, modules, circuits, and algorithm steps described in connection with the embodiments disclosed herein can be implemented as electronic hardware, computer software, or combinations of both. To clearly illustrate this interchangeability of hardware and software, various illustrative components, blocks, modules, circuits, and steps have been described above generally in terms of their functionality. Whether such functionality is implemented as hardware or software depends upon the particular application and design constraints imposed on the overall system. The described functionality can be implemented in varying ways for each particular application, but such embodiment decisions should not be interpreted as causing a departure from the scope of the disclosure.

[0071] The various illustrative logical blocks, modules, and circuits described in connection with the embodiments disclosed herein can be implemented or performed with a general purpose processor, a digital signal processor (DSP), an application specific integrated circuit (ASIC), a field programmable gate array (FPGA) or other programmable logic device, discrete gate or transistor logic, discrete hardware components, or any combination thereof designed to perform the functions described herein. A general purpose processor can be a microprocessor, but in the alternative, the processor can be any conventional processor, controller, microcontroller, or state machine. A processor can also be implemented as a combination of computing devices, e.g., a combination of a DSP and a microprocessor, a plurality of microprocessors, one or more microprocessors in conjunction with a DSP core, or any other such configuration.

[0072] The blocks of the methods and algorithms described in connection with the embodiments disclosed herein can be embodied directly in hardware, in a software module executed by a processor, or in a combination of the two. A software module can reside in RAM memory, flash memory, ROM memory, EPROM memory, EEPROM memory, registers, a hard disk, a removable disk, a CD-ROM, or any other form of computer-readable storage medium known in the art. An exemplary storage medium is coupled to a

processor such that the processor can read information from, and write information to, the storage medium. In the alternative, the storage medium can be integral to the processor. The processor and the storage medium can reside in an ASIC. The ASIC can reside in a user terminal. In the alternative, the processor and the storage medium can reside as discrete components in a user terminal.

[0073] While the above detailed description has shown, described, and pointed out novel features as applied to various embodiments, it will be understood that various omissions, substitutions, and changes in the form and details of the devices or algorithms illustrated can be made without departing from the spirit of the disclosure. As will be recognized, certain embodiments of the disclosures described herein can be embodied within a form that does not provide all of the features and benefits set forth herein, as some features can be used or practiced separately from others. The scope of certain disclosures disclosed herein is indicated by the appended claims rather than by the foregoing description. All changes which come within the meaning and range of equivalency of the claims are to be embraced within their scope.

Below are descriptions of various features that can be incorporated into a medical device to determine a position of the medical device in living tissue. A clinician can use this information to guide the medical device to an optimal tissue site. The medical device can include one or more of the features described below.

Certain examples described herein are discussed with respect to a needle, but the needle can be any needle-based device, such as a standard needle, syringe, biopsy needle, or the like. Further, the examples can be applied to other medical devices inserted into patients, such as catheters, gastric feeding tubes, tracheostomy tubes, or other medical devices.

It should be understood that the medical devices can be used in the face, shoulder, knee, spine, or any other part of the anatomy of a human or animal.

System for Avoiding Blood Vessels

As described above, it can be useful to determine whether a distal tip of a medical device is positioned in a blood vessel. For example, if the clinician is withdrawing blood, an indication of whether the needle has entered the blood

vessel could be useful. As another example, it may be preferable to inject a therapeutic agent in a specific location (e.g., blood vessel, muscle, subcutaneous tissue, or otherwise), thus an indication of whether the needle has indeed entered that layer of tissue could be useful. This information can help improve medical outcomes and patient safety.

Figures 1 and 2 illustrate a system for detecting whether a distal tip of a medical device has entered a blood vessel. In the illustrated example, the system includes a needle-based device. The system can determine whether the distal tip of the needle is positioned in a blood vessel by detecting pressure, motion, vibration, or the like. For example, if turbulent motion is detected at the distal tip of the needle, then it is likely that the distal tip of the needle is in a blood vessel. If less than turbulent motion is detected at the distal tip of the needle, then it is likely that the distal tip of the needle is not within the blood vessel.

In general, system can include a sensor to detect the motion, pressure, and/or vibration. The sensor can be positioned in a hub of the needle, any other portion of the needle, or separately connected to the needle. If necessary, the sensor can be conductively connected to an amplifier magnify the signal. The needle can display the signal on the device itself or a separate display device connected to the needle (e.g., a tablet, computer screen, or otherwise).

The system can also include one or more processors, which may be integrated with the needle or separately connected. The processor can be configured to analyze the signal to provide a user-friendly output, such as a binary output indicative of whether or not the distal tip is positioned within a blood vessel. The user-friendly output can be determined by comparing a frequency of the waveform to a threshold value. For example, if the frequency is less than the threshold value, then the distal tip of the needle is in the blood vessel. On the other hand, if the frequency is greater than the threshold value, then the distal tip of the needle is not within the blood vessel. In some instances, the threshold value may be determined based on initial readings from the current procedure or readings from a previous procedure. In other instances, the threshold value can be determined based on a patient population.

In the illustrated example, the sensor is a piezoelectric sensor conductively conducted to an amplifier. The piezoelectric sensor can include pressure and/or acceleration sensing elements to detect motion at the distal tip of the needle.

The sensor can generate a signal based on the detected motion. As shown in Figure 3, if the tip of the needle is outside the blood vessel, the sensor only detects tissue deflection from pulsing blood pressure. In contrast, if the tip of the needle is within the blood vessel, the sensor detects the turbulence of actual blood flow, which has a higher frequency compared to the waveform outside the tissue. The system may output the waveform alone, and/or the system may process this data to provide a user-friendly output as outlined above.

System for Determining Proximity to a Nerve

As described above, it can be useful to determine whether a distal tip of a medical device is close a nerve because actual contact with the never can be painful.

Figures 4 and 5 illustrate a system for detecting whether a distal tip of a medical device is in proximity to a nerve. In the illustrated example, the system includes a needle-based device. The system can determine whether the distal tip of the needle is in proximity to a nerve assessing a response to an electrical pulse. In general, as the response increases, the distal tip of the needle is closer to a nerve.

The system can include a pulse generator separately connected to the needle-based device and a sensor for detecting a response to the generated pulse. The system can output the signal generated by the sensor. The system can also include one or more processors, which can be integrated with the needle or separately connected. The processor can be configured to analyze the signal generated from the response to provide a user-friendly output indicative of how close the distal tip is to a nerve. The user-friendly output can be a numerical distance or a scaled output (e.g., color scale or numerical scale) proportional to the proximity of the distal tip to the nerve. In some implementations, the output can be a binary indication of whether to continue advancing the needle or whether to inject the therapeutic agent. The system can be configured based on data from an initial reading from the current procedure or a reading from a previous procedure. Alternatively, the system can be configured based on data from a patient population. The system can provide the binary indication by comparing the generated response to a threshold value indicative of being too close to a nerve. The system can output the indication to a display device that

can be part of the medical device, the pulse generator, the pulse detector, or a separate component.

In the illustrated example, the system includes a pulse generator configured to supply a small electrical current to the needle or otherwise supply a small current to the patient to assess nerve response. The pulse generator can be a separate component connected to a syringe using a clip. When the pulse generator is connected to the syringe, the pulse generator can extend distally toward a distal tip of the needle. The system can also include a mechanism for detecting a response to the pulse. This detection mechanism can be in the same housing as the pulse generator. As shown in Figure 4, the pulse detection mechanism can assess a physiological response to the generated pulse by outputting a light pattern on the patient's skin and detecting movement of the light pattern. When the pulse is applied to the patient, the muscles will flex, which will cause the light pattern to move. As the distal tip of the needle moves closer to a nerve, the muscle flexure increases, which causes increased light pattern movement. The system can output a signal indicative of the level of movement, and/or the system can process this data to provide a user-friendly output as outlined above.

System for Determining Depth

In some treatments, it may be useful to understand the distance between the distal tip of a medical device and the patient's skin, for example to increase the efficacy of an injected therapeutic agent. It may also be useful to understand the distance between the distal tip of the medical device and the patient's bone to avoid hurting the patient.

Figures 6 and 7 illustrate a system for determining the distance between the distal tip of a medical device and the patient's skin and/or between the distal tip of the medical device and the patient's bone. The system can include a pulse generator separately connected to the needle-based device and a sensor for detecting a response to the generated pulse. The system can include one or more processors, which may be integrated with the needle or separately connected. The processor can be configured to analyze the signal generated from the response to provide a user-friendly output indicative of a distance between a distal tip of the needle to the patient's skin and/or the patient's bone.

The system can output the distance to a display device that may be part of the medical device, the pulse generator, or a separate component.

In the illustrated example, the system includes a pulse generator configured to apply a mechanical pulse by tapping the patient's skin. The pulse generator can include a body mounted to the syringe. A spring-loaded arm can extend from the body and toward a distal tip of the needle. When the spring-loaded arm moves, a distal portion of the pulse generator can tap the patient's skin near the needle tip. A vibration sensor can be configured to detect vibrations in the needle in response to the pulse generator. The vibration sensor can be positioned in a hub portion of the needle. A processing unit can perform a process that determines a time delay between the application of the mechanical pulse and the receipt of a signal indicative of needle vibration. Based on the time delay, the process can determine a distance between the distal tip of the needle and the patient's skin. The distance can be determined using math modeling or by comparing the time delay to a threshold value for that specific patient or from a patient population. The processor may be configured to discount the signal or time delay using baseline data indicative of baseline vibrations from the patient's pulse. The system can output the distance to a display device on the syringe or separate from the syringe.

In some implementations, the vibration sensor may detect secondary vibrations as the mechanical pulse reflects off the bone and toward the tip of the needle. The processing unit can determine a time delay between the application of the mechanical pulse and receipt of a signal indicative of the secondary vibrations, or determine a time delay between receipt of the first signal from the initial vibrations and receipt of the second signal from the secondary vibrations. The processing unit can perform a process to determine a distance between the distal tip of the needle and the bone based on this second time delay. The distance can be determined using math modeling or by comparing the second time delay to a threshold value for that specific patient or from a patient population. The system can output the numerical distance to a display device on the syringe or separate from the syringe.

Virtual Reality System

As shown in Figure 8, an augmented or virtual reality display (e.g., wearable glasses or as otherwise described above) can be used to overlay a computer-generated three-dimensional image on a patient. The computer-generated image(s) can correspond to one or more layers of anatomy (e.g., bones, nerves, blood vessels, or the like) for that specific patient. The images can be obtained using a CT scan, an MRI scan, a photographic image, an X-ray, and/or the like.

Figure 9 illustrates an example of an image that can be seen on the display. This image can be aligned with the patient's face using one or more alignment targets. For example, these alignment targets can be anatomical features, such as the center of an eyeball or an apex of the nose. As another example, these targets can be alignment markers (e.g., reflective beads) that can be positioned on the patient when the MRI image is captured, such that the markers appear in the MRI image(s). As shown in Figure 8, a plurality of markers can be positioned around an outer periphery of the patient's face. These alignment markers can remain on the patient or be positioned again on the patient in the same location for the actual procedure. During the procedure, the clinician can align the markers in the computer generated image with the markers on the patient's face. In some implementations, the display system can include a camera that captures the location of the alignment markers during the actual procedure and automatically aligns the markers in the computer generated image with the markers on the patient's face.

When this image is meshed with the patient, the locations of structures in the image correspond to the actual location of those structures in the patient. The ability to visualize the tissue layers as the clinician is performing a procedure can help the clinician perform the procedure at an optimal location. For example, this system can be used to guide a syringe to an appropriate depth for a therapeutic injection. The movement of the syringe can be seen on the display device. Thus, as the syringe is moved through the actual patient, the location of the distal tip of the syringe can be seen on the computer-generated image. When the distal tip of the syringe is positioned in the target location in the image, the distal tip of the syringe is positioned in the target location in the actual patient.

Terminology

Conditional language used herein, such as, among others, "can," "could," "might," "may," "e.g.," and the like, unless specifically stated otherwise, or otherwise understood within the context as used, is generally intended to convey that certain embodiments include, while other embodiments do not include, certain features, elements and/or steps. Thus, such conditional language is not generally intended to imply that features, elements and/or steps are in any way required for one or more embodiments or that one or more embodiments necessarily include logic for deciding, with or without other input or prompting, whether these features, elements and/or steps are included or are to be performed in any particular embodiment. The terms "comprising," "including," "having," and the like are synonymous and are used inclusively, in an open-ended fashion, and do not exclude additional elements, features, acts, operations, and so forth. Also, the term "or" is used in its inclusive sense (and not in its exclusive sense) so that when used, for example, to connect a list of elements, the term "or" means one, some, or all of the elements in the list.

Any methods disclosed herein need not be performed in the order recited. The methods disclosed herein include certain actions taken by a practitioner; however, they can also include any third-party instruction of those actions, either expressly or by implication. For example, actions such as "inserting the testing tool" include "instructing insertion of a testing tool."

All of the methods and tasks described herein may be performed and fully automated by a computer system. The computer system may, in some cases, include multiple distinct computers or computing devices (e.g., physical servers, workstations, storage arrays, cloud computing resources, etc.) that communicate and interoperate over a network to perform the described functions. Each such computing device typically includes a processor (or multiple processors) that executes program instructions or modules stored in a memory or other non-transitory computer-readable storage medium or device (e.g., solid state storage devices, disk drives, etc.). The various functions disclosed herein may be embodied in such program instructions, and/or may be implemented in application-specific circuitry (e.g., ASICs or FPGAs) of the computer system. Where the computer system includes multiple computing devices, these devices may, but need not, be co-located. The results of the disclosed methods and

tasks may be persistently stored by transforming physical storage devices, such as solid state memory chips and/or magnetic disks, into a different state. In some embodiments, the computer system may be a cloud-based computing system whose processing resources are shared by multiple distinct business entities or other users.

Depending on the embodiment, certain acts, events, or functions of any of the processes or algorithms described herein can be performed in a different sequence, can be added, merged, or left out altogether (e.g., not all described operations or events are necessary for the practice of the algorithm). Moreover, in certain embodiments, operations or events can be performed concurrently, e.g., through multi-threaded processing, interrupt processing, or multiple processors or processor cores or on other parallel architectures, rather than sequentially.

The various illustrative logical blocks, modules, routines, and algorithm steps described in connection with the embodiments disclosed herein can be implemented as electronic hardware (e.g., ASICs or FPGA devices), computer software that runs on general purpose computer hardware, or combinations of both. Various illustrative components, blocks, and steps have been described above generally in terms of their functionality. Whether such functionality is implemented as specialized hardware versus software running on general-purpose hardware depends upon the particular application and design constraints imposed on the overall system. The described functionality can be implemented in varying ways for each particular application, but such implementation decisions should not be interpreted as causing a departure from the scope of the disclosure.

Moreover, the various illustrative logical blocks and modules described in connection with the embodiments disclosed herein can be implemented or performed by a machine, such as a general purpose processor device, a digital signal processor (DSP), an application specific integrated circuit (ASIC), a field programmable gate array (FPGA) or other programmable logic device, discrete gate or transistor logic, discrete hardware components, or any combination thereof designed to perform the functions described herein. A general purpose processor device can be a microprocessor, but in the alternative, the processor device can be a controller, microcontroller, or state machine, combinations of the

same, or the like. A processor device can include electrical circuitry configured to process computer-executable instructions. In another embodiment, a processor device includes an FPGA or other programmable device that performs logic operations without processing computer-executable instructions. A processor device can also be implemented as a combination of computing devices, e.g., a combination of a DSP and a microprocessor, a plurality of microprocessors, one or more microprocessors in conjunction with a DSP core, or any other such configuration. Although described herein primarily with respect to digital technology, a processor device may also include primarily analog components. For example, some or all of the rendering techniques described herein may be implemented in analog circuitry or mixed analog and digital circuitry. A computing environment can include any type of computer system, including, but not limited to, a computer system based on a microprocessor, a mainframe computer, a digital signal processor, a portable computing device, a device controller, or a computational engine within an appliance, to name a few.

The elements of a method, process, routine, or algorithm described in connection with the embodiments disclosed herein can be embodied directly in hardware, in a software module executed by a processor device, or in a combination of the two. A software module can reside in RAM memory, flash memory, ROM memory, EPROM memory, EEPROM memory, registers, hard disk, a removable disk, a CD-ROM, or any other form of a non-transitory computer-readable storage medium. An exemplary storage medium can be coupled to the processor device such that the processor device can read information from, and write information to, the storage medium. In the alternative, the storage medium can be integral to the processor device. The processor device and the storage medium can reside in an ASIC. The ASIC can reside in a user terminal. In the alternative, the processor device and the storage medium can reside as discrete components in a user terminal.

While the above detailed description has shown, described, and pointed out novel features as applied to various embodiments, it can be understood that various omissions, substitutions, and changes in the form and details of the devices or algorithms illustrated can be made without departing from the spirit of the disclosure. As can be recognized, certain embodiments described herein can be embodied within a form that does not provide all of the features and benefits

set forth herein, as some features can be used or practiced separately from others. The scope of certain embodiments disclosed herein is indicated by the appended claims rather than by the foregoing description. All changes which come within the meaning and range of equivalency of the claims are to be embraced within their scope.

CLAIMS

WHAT IS CLAIMED IS:

1. A physiological mapping device comprising:
 - a sensor configured to detect a physiological feature beneath a surface of a subject;
 - an information processor configured to receive information indicative of the physiological feature and identify the physiological feature based on the received information; and
 - a marking element configured to produce a visible mark on the surface identifying the physiological feature based on the received identification.

2. The device of Claim 1, wherein the sensor comprises one of a piezoelectric sensor, a microphone, an antenna, a gyroscope, or an accelerometer.

3. The device of Claim 1, wherein the physiological feature comprises one of a vein, an artery, or a nerve.

4. The device of Claim 1, wherein the information processor is further configured to determine a depth of the identified physiological feature beneath the surface based on the received information indicative of the physiological feature, and
 - wherein the marking element is further configured to produce the visible mark to further identify the depth.

5. The device of Claim 1, further comprising an emitter, wherein the information indicative of the physiological feature comprises a reflected portion of a signal transmitted by the emitter, and wherein the information processor is configured to identify the physiological feature based on a comparison of the signal transmitted by the emitter and the information indicative of the physiological feature.

6. The device of Claim 1, wherein the sensor and the marking element are formed in a head, and wherein the information processor is formed in a base, and wherein the head is detachable from the base.

7. A physiological mapping device head comprising:
a sensor configured to detect emissions from a physiological feature beneath a surface of a subject;
a coupling configured to transmit detected emissions to an information processor and receive physiological information from the information processor; and
a marking element configured to receive an identification of the physiological feature from an information processor via the coupling and produce a visible mark on the surface identifying the physiological feature based on the received identification.

8. A physiological mapping device body comprising:
a coupling configured to exchange data with a head, said head including a sensor and a marking element; and
an information processor configured to:
receive emissions from a physiological feature beneath a surface of a subject from the sensor; and
transmit an identification of the physiological feature to the marking element, said identification including information, in part, causing the production of a visible mark on the surface identifying the physiological feature.

9. A nerve safe needle comprising:
a tip formed of an electrically conductive material; and
a power source coupled with the tip, wherein upon contact with a nerve, a circuit is completed with the tip and the power source to deliver a current at the tip.

10. The nerve safe needle of Claim 9, wherein the circuit is configured to deliver a current sufficient to cause a physiological response.

11. An aspirating needle comprising:
 - a hollow needle tip coupled with a chamber, the chamber including a first channel to an injectable reservoir and a second channel to an aspirator reservoir,
 - the aspirator reservoir including:
 - an oscillating member configured to oscillate a fluid between the aspirator reservoir to the hollow needle tip;
 - a light source affixed on a wall of the aspirator reservoir and configured to emit light of a predetermined quality; and
 - a light detector affixed on the wall of the aspirator reservoir opposite the light source such that a center point of the light source is aligned with a center point of the light detector, said light detector configured to detect a characteristic of the light emitted from the light source through the fluid in the aspirator reservoir.
1. A system for determining whether a medical device is within a blood vessel, the system comprising:
 - a needle comprising a distal tip;
 - a hub at a proximal end of the needle, the hub comprising a sensor for detecting motion at the distal tip of the needle, the sensor configured to generate a signal based on the detected motion; and
 - a processing unit configured to perform a process, the process comprising:
 - comparing a frequency of the signal to a threshold value; and
 - providing an indication of whether the distal tip of the needle is in the blood vessel based on the comparison between the frequency of the signal and the threshold value.
2. The system of Claim 1, further comprising a display configured to display the indication of whether the distal tip of the needle is in the blood vessel.
3. The system of Claim 2, wherein the hub comprises the display.

4. The system of Claim 2 or 3, wherein the indication is a binary output indicative of whether the distal tip of the needle is in the blood vessel.

5. The system of any one of Claims 1 to 4, wherein the sensor is a piezoelectric sensor.

6. A system for determining a proximity of a medical device to a nerve, the system comprising:

the medical device comprising a syringe, the syringe comprising a body and a needle;

a pulse generator configured to supply an electrical current to the needle;

a detector configured to detect a physiological response to the electrical current and generate a signal; and

a processing unit configured to perform a process, the process comprising:

comparing the generate signal to a threshold value; and

providing an indication representative of the proximity of a distal tip of the needle to a nerve based on the comparison between the generated signal and the threshold value.

7. The system of Claim 6, further comprising a housing comprising the pulse generator and the detector.

8. The system of Claim 7, wherein the housing is connected to the body of the syringe using a clip.

9. The system of Claim 7 or 8, wherein the housing extends distally toward a distal tip of the needle.

10. The system of any one of Claims 6 to 9, further comprising a light pattern generator configured to output a light pattern on a patient's skin.

11. The system of Claim 10, wherein the detector is configured to detect movement of the light pattern.

12. The system of any one of Claims 6 to 11, wherein the indication is a binary output indicative of whether the needle should be advanced.

13. A system for determining a depth of insertion for a medical device, the system comprising:

the medical device comprising a syringe, the syringe comprising a body and a needle;

a pulse generator configured to supply a mechanical pulse to a patient's skin at a first time mark;

a vibration sensor configured to detect a first vibration of the needle in response to the mechanical pulse at a second time mark; and

a processing unit configured to perform a process, the process comprising:

determining a first time delay between the first time mark and the second time mark; and

determining a distance between the patient's skin and a distal tip of the needle based on the first time delay.

14. The system of Claim 13, wherein the pulse generator comprises a mount connected to the body of the syringe and a spring-loaded arm extending from the mount, the mechanical pulse being generated by movement of the spring-loaded arm.

15. The system of Claim 13 or 14, wherein the vibration sensor is configured to detect a second vibration of the needle at a third time mark.

16. The system of Claim 15, wherein the process further comprises:

determining a second time delay between the second time mark and the third time mark;

determining a distance between the distal tip of the needle and a bone based on the second time delay.

17. An system comprising:

a computing system having at least one processor and a memory device, the computing system configured to generate a virtual environment

comprising a graphical representation at least one layer of tissue of a patient; and

a display device, coupled to the computing system, the display device configured to mesh the virtual environment on the patient, such that a location in the virtual environment is aligned with a same location in the patient.

18. The system of Claim 17, wherein the graphical representation is based on at least one MRI image.

19. The system of Claim 17 or 18, further comprising a plurality of alignment markers configured to be positioned on the patient to align the graphical representation with the patient.

20. The system of Claim 19, further comprising a camera to capture locations of the plurality of alignment marks to automatically align the graphical representation with the patient.

INCORPORATED BY REFERENCE (RULE 20.6)

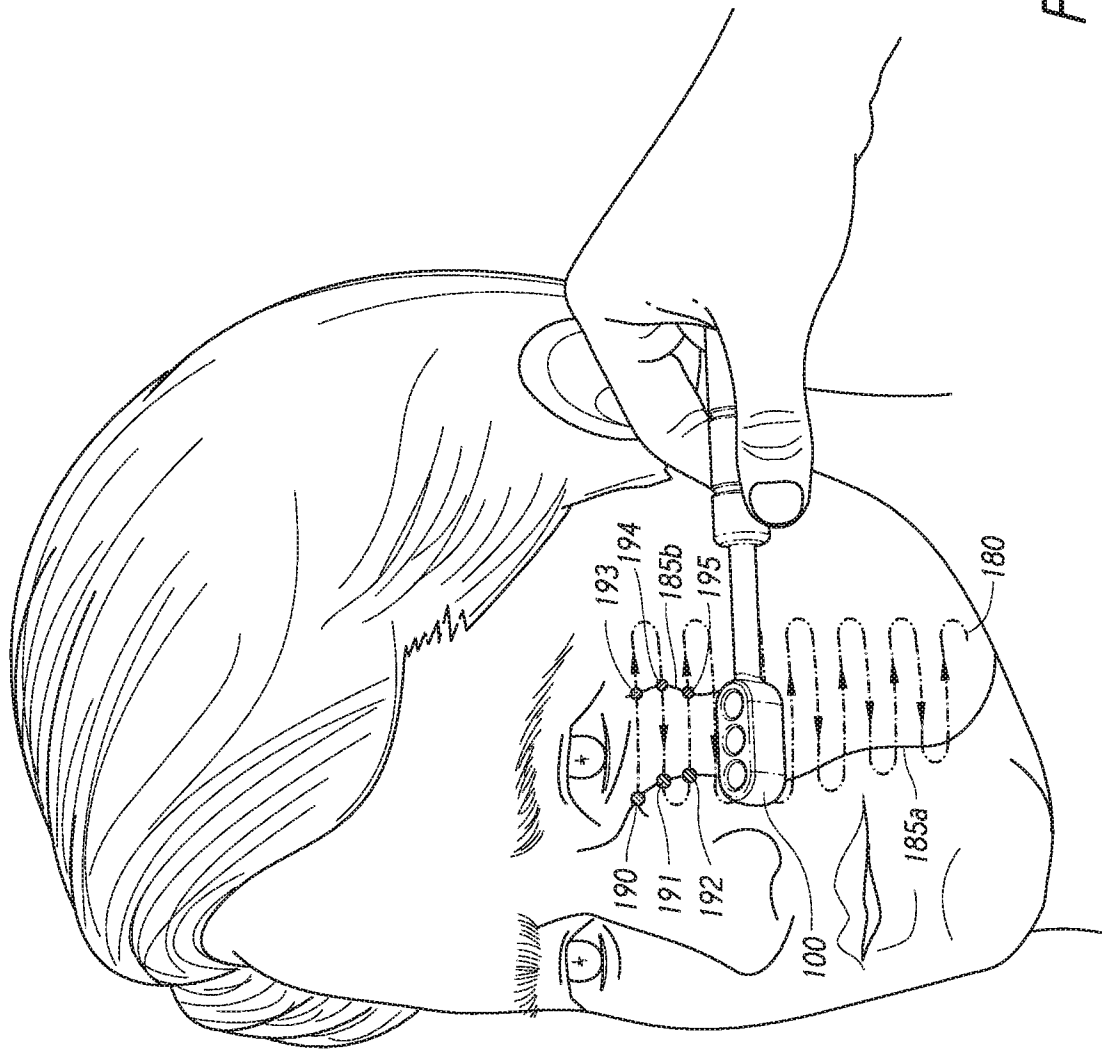

FIG. 1

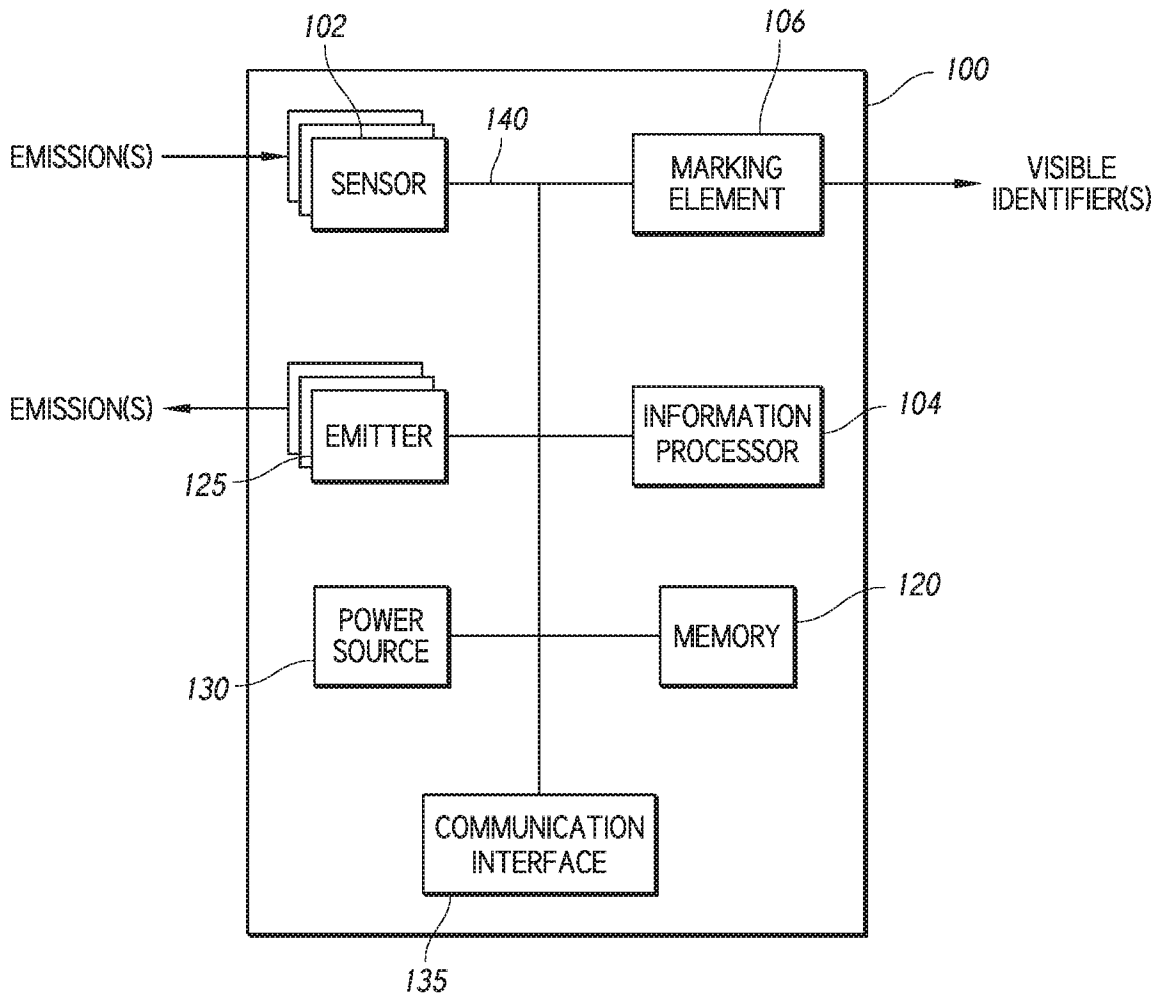

FIG. 2A

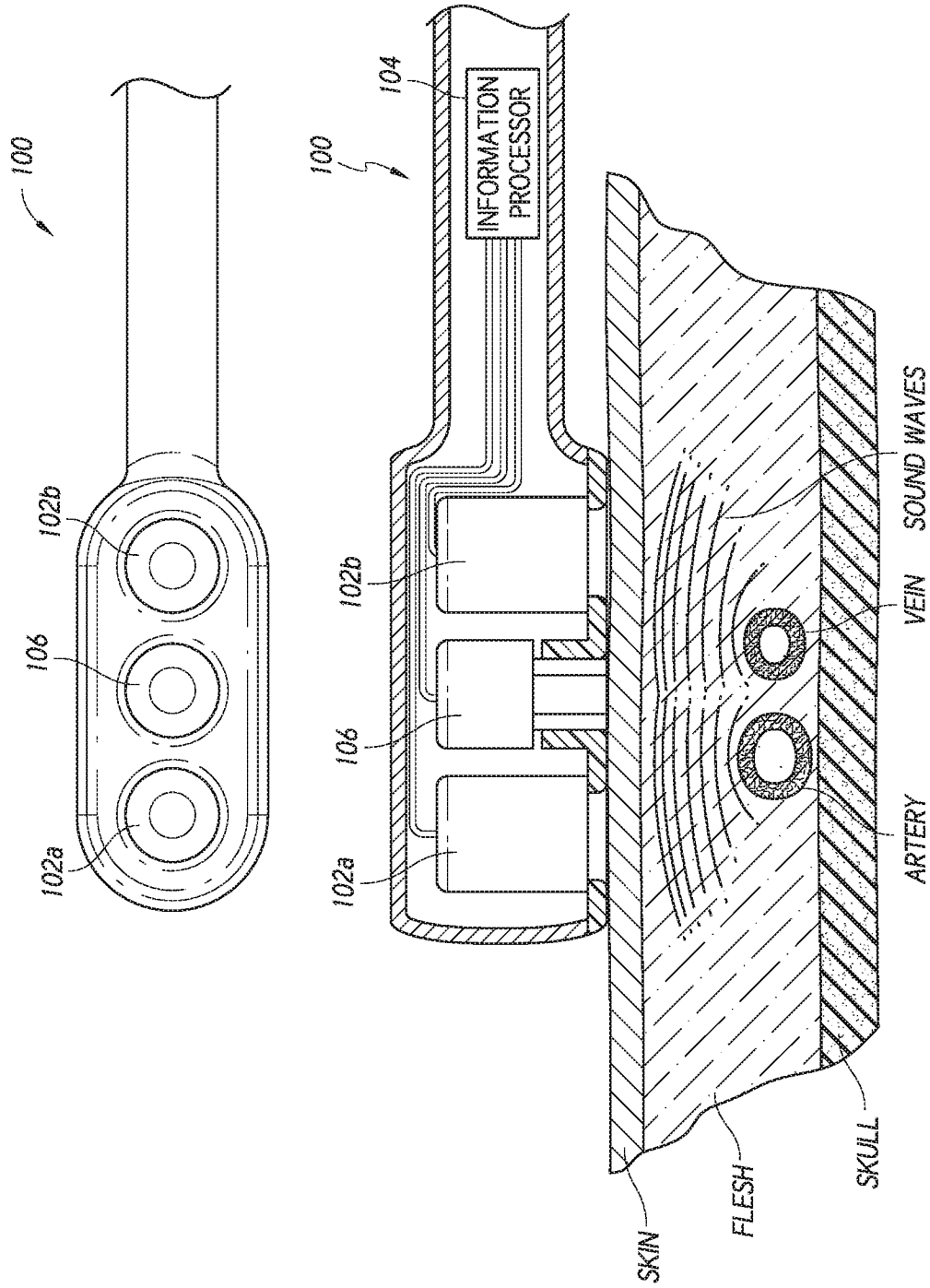
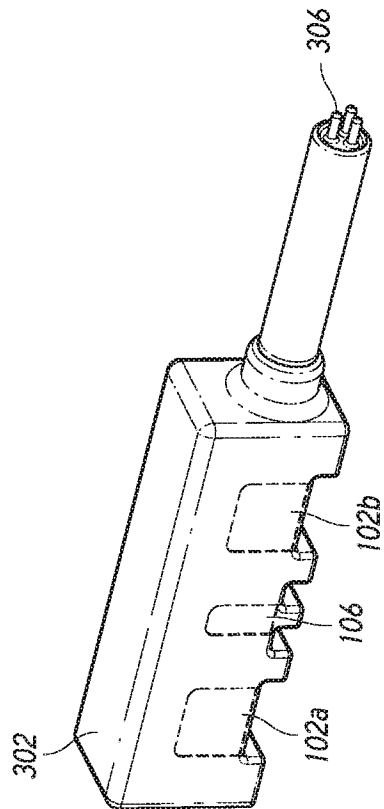
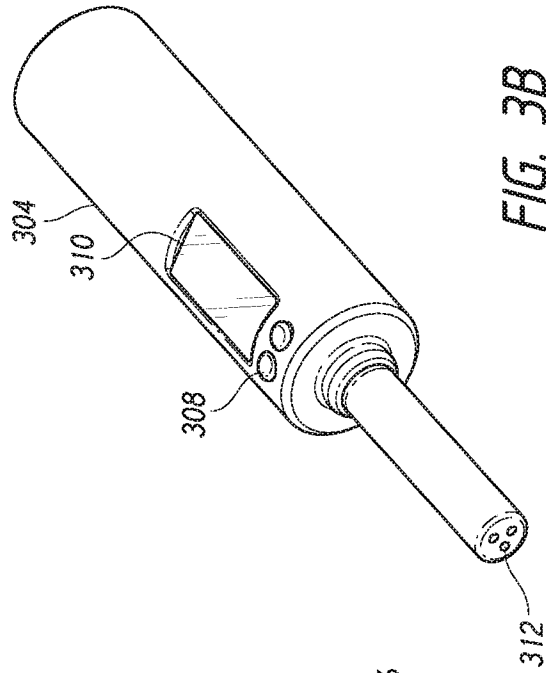

FIG. 2B



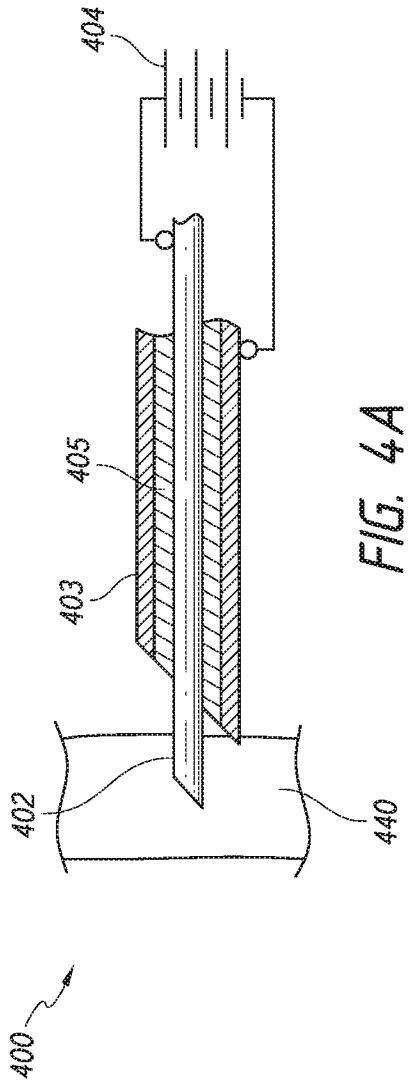

FIG. 4A

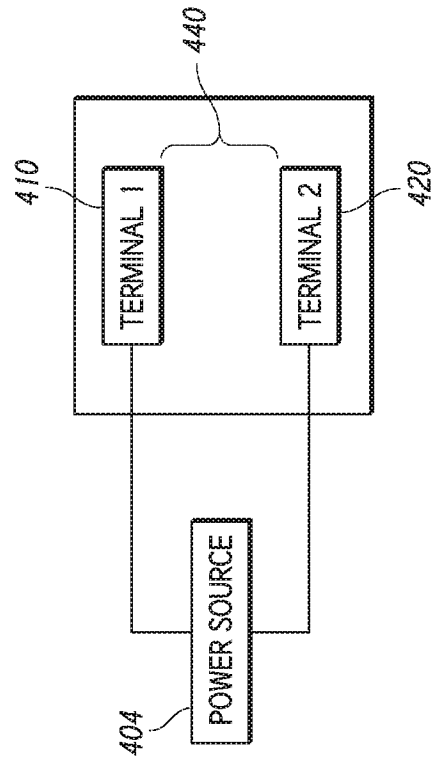

FIG. 4B

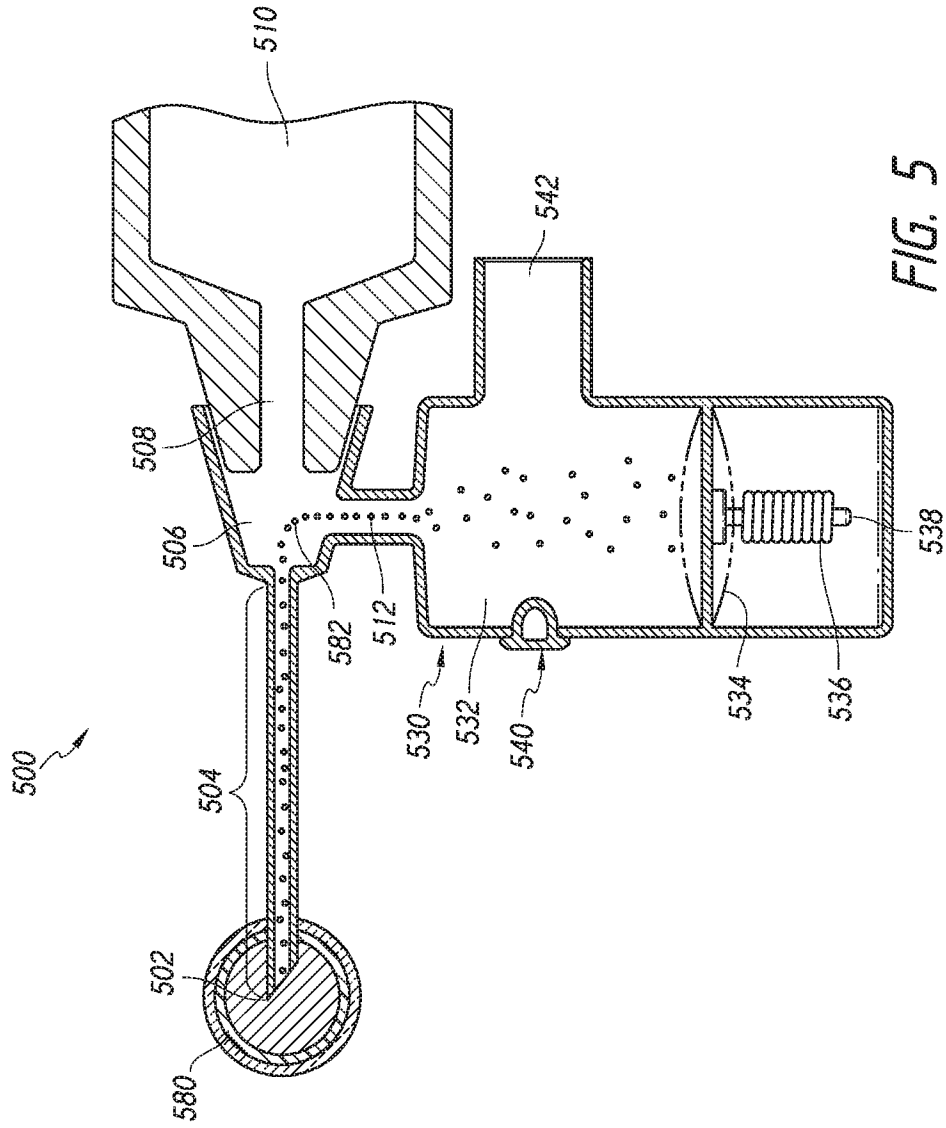

FIG. 5

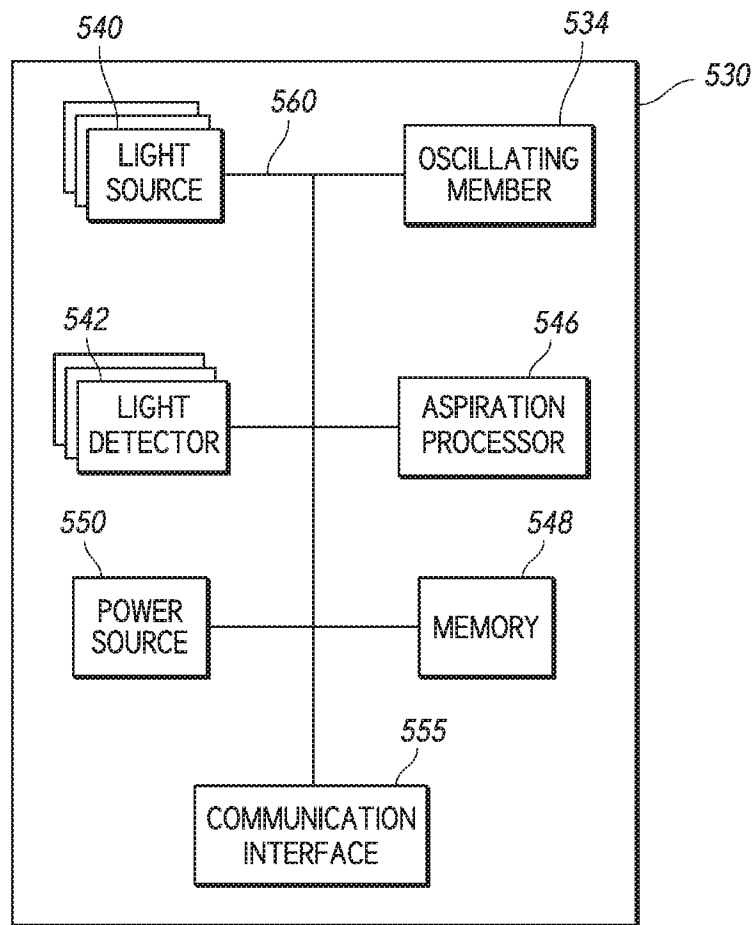

FIG. 6

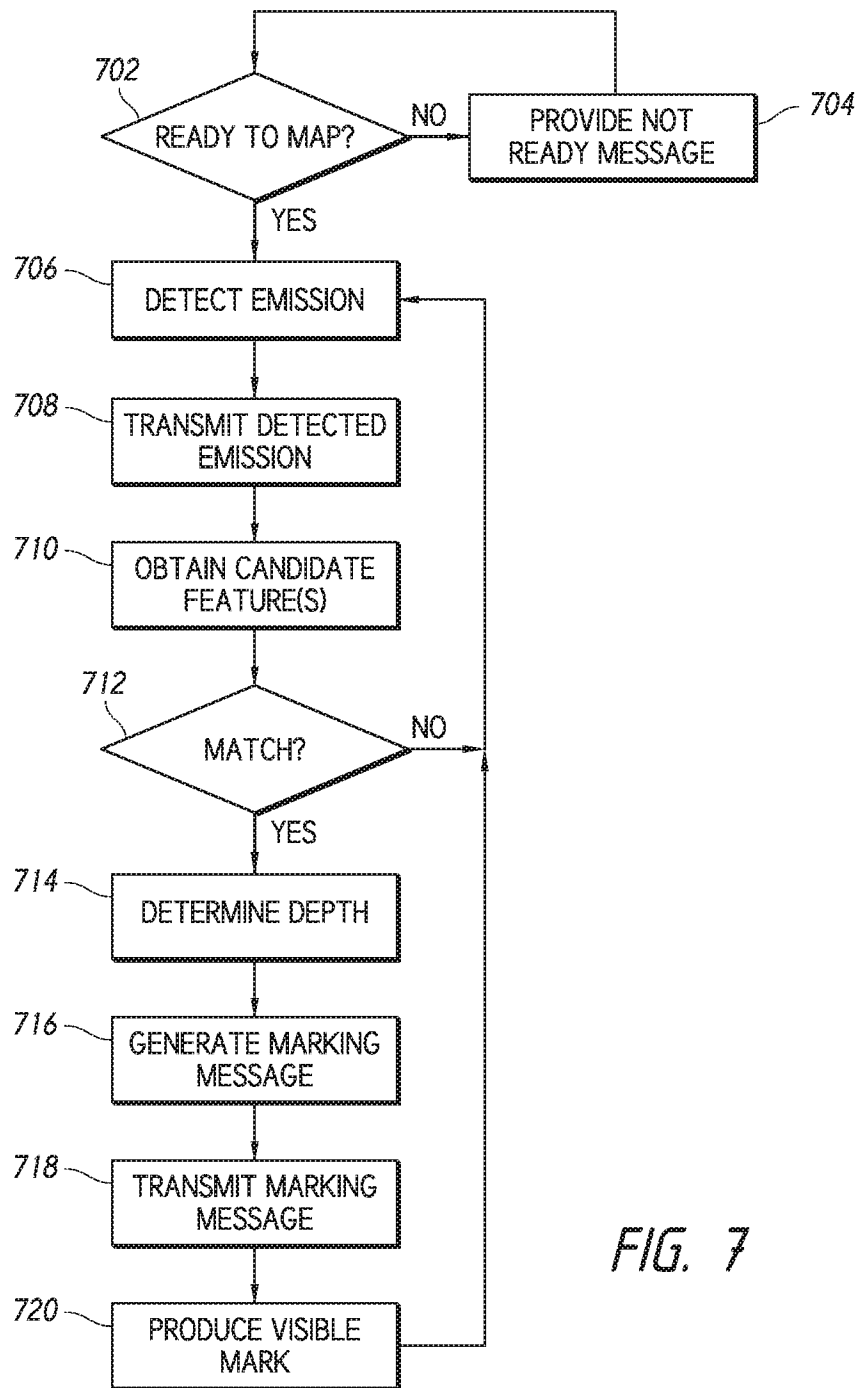

FIG. 7

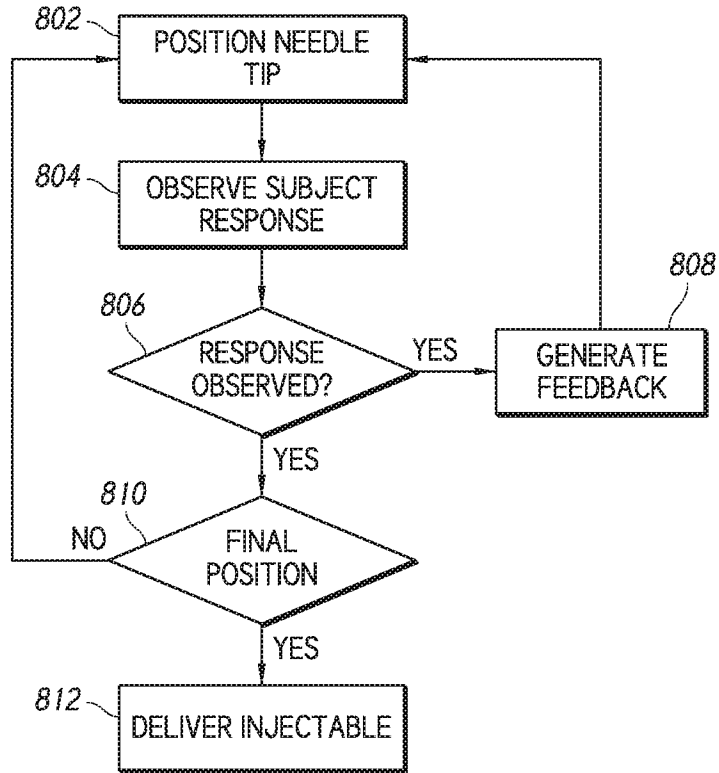

FIG. 8

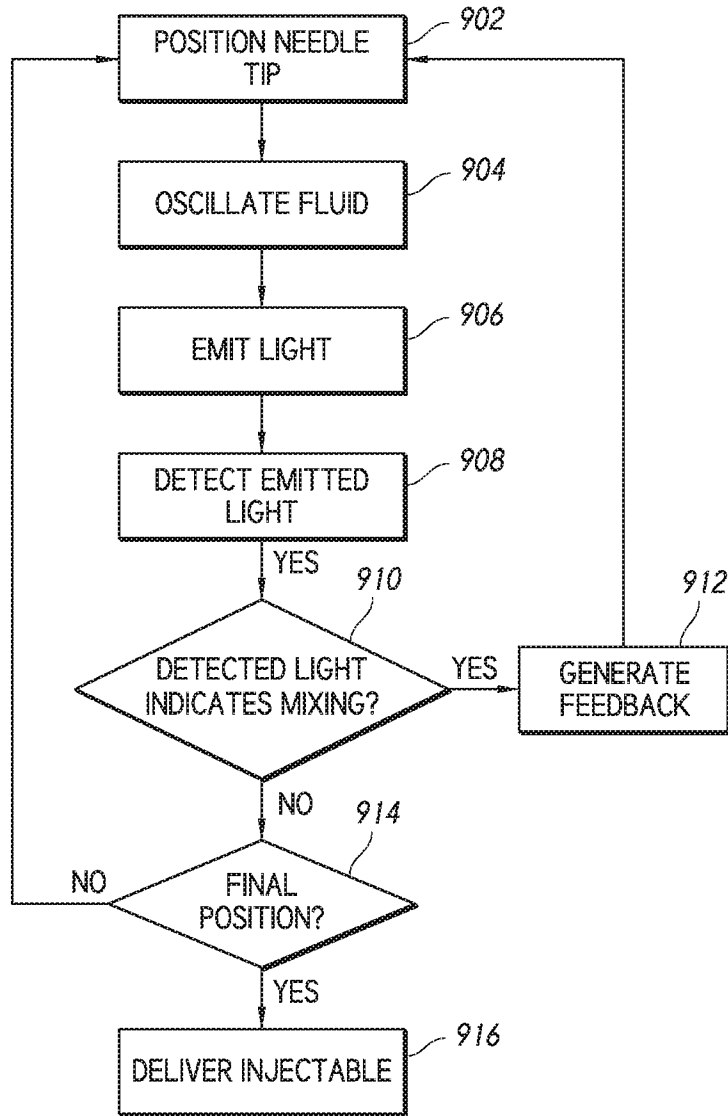

FIG. 9

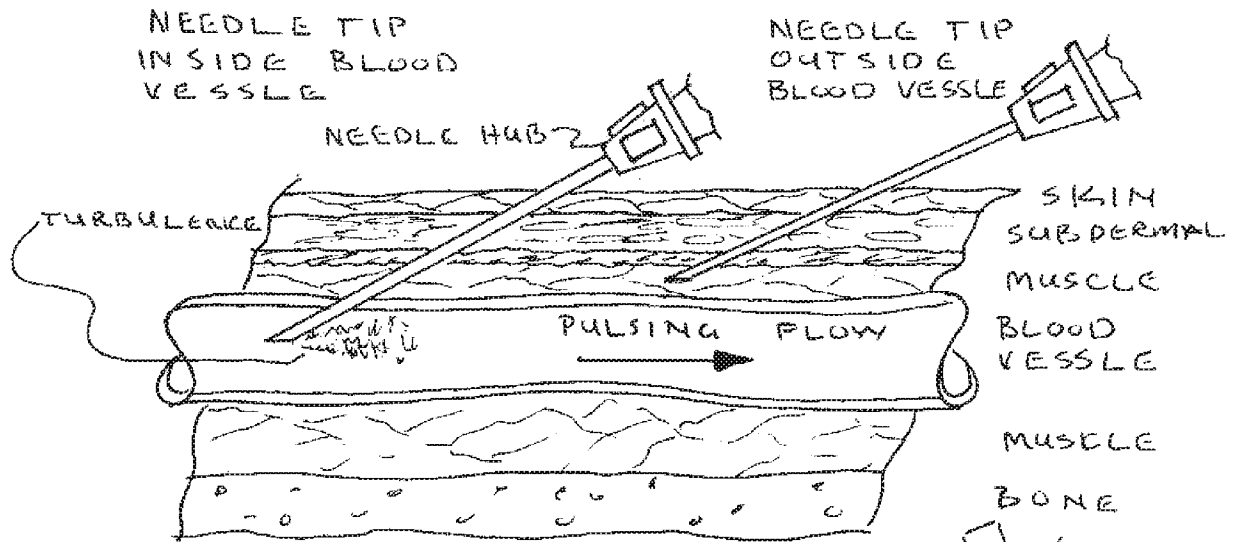

FIG 1

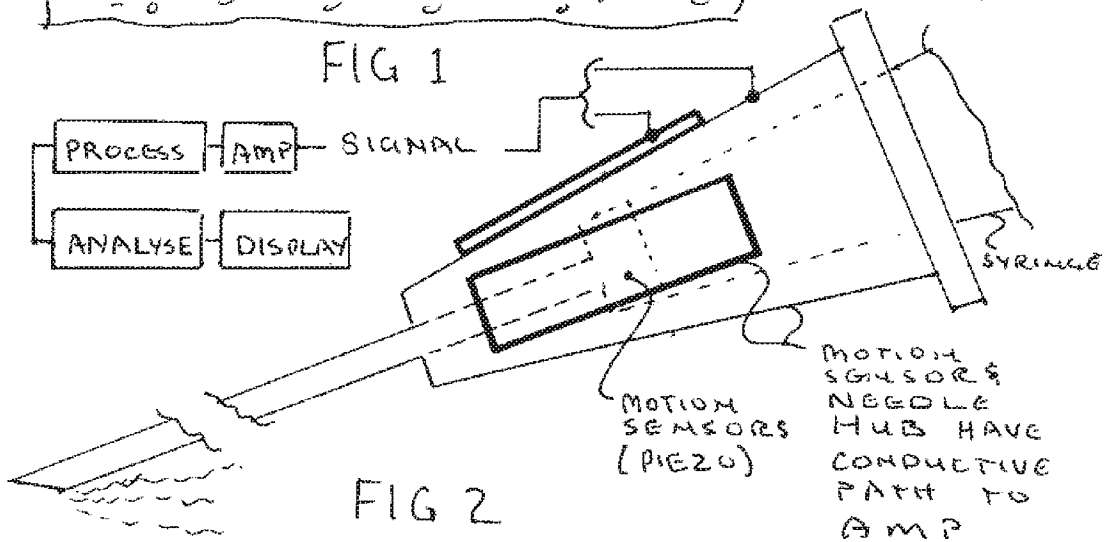

FIG 2

12/16

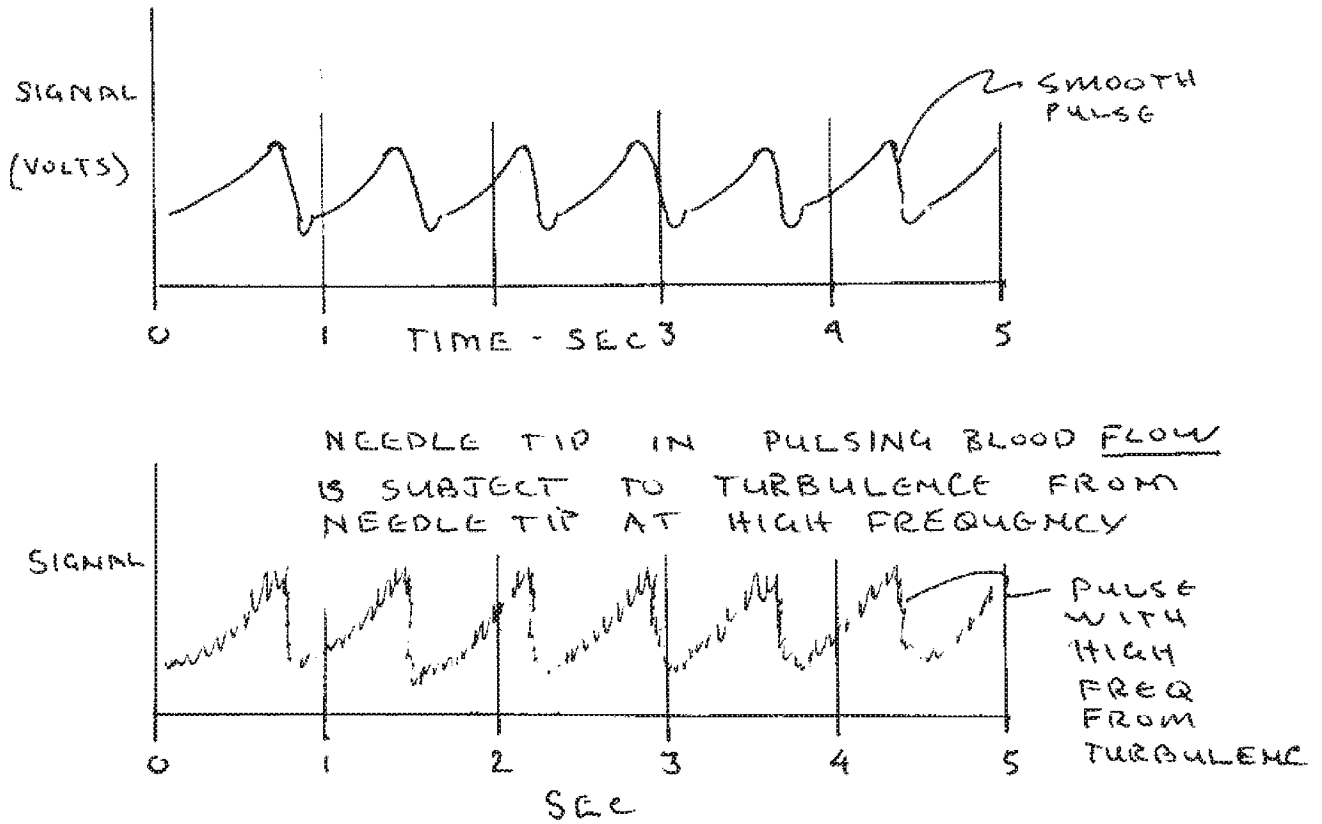
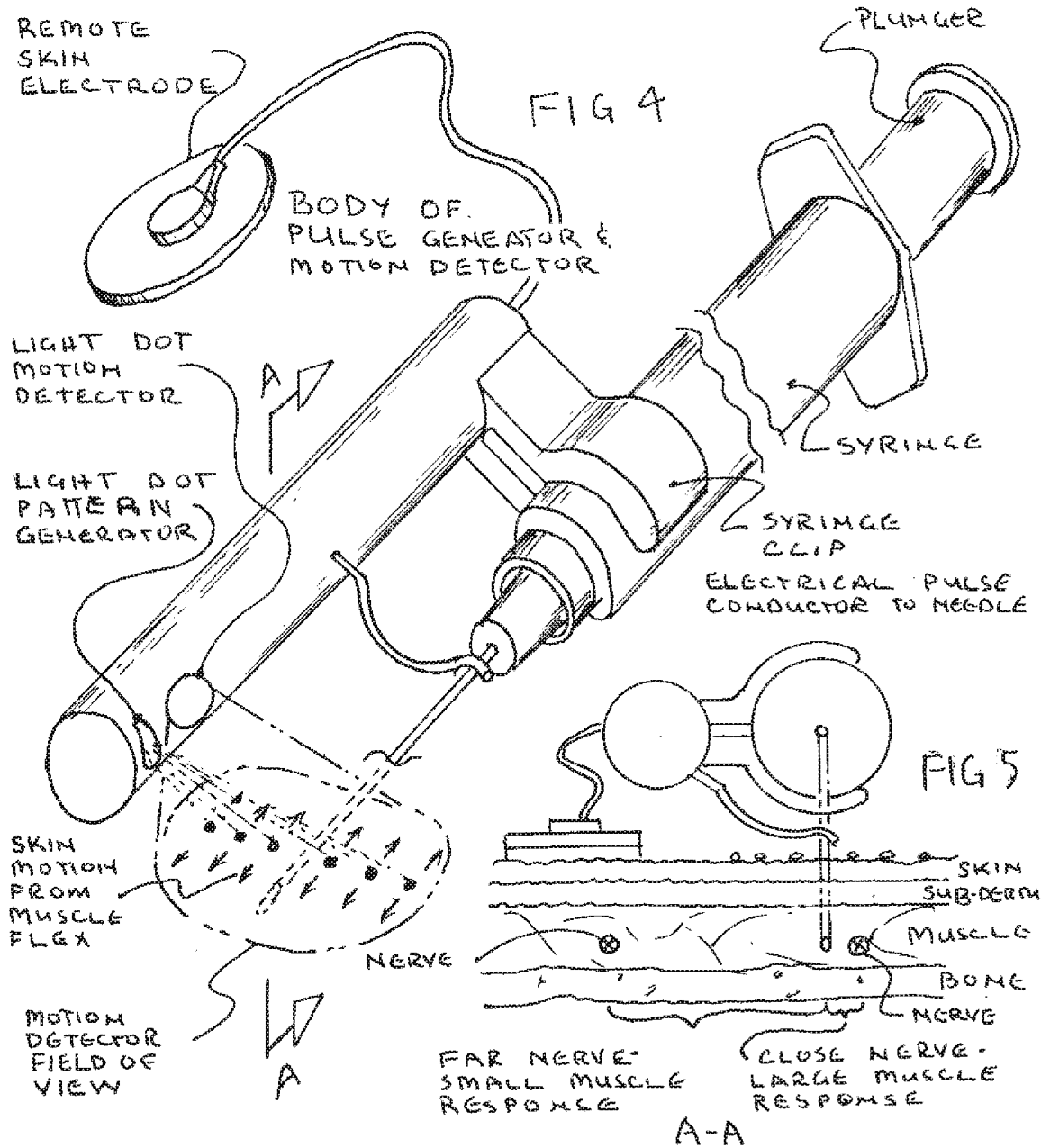
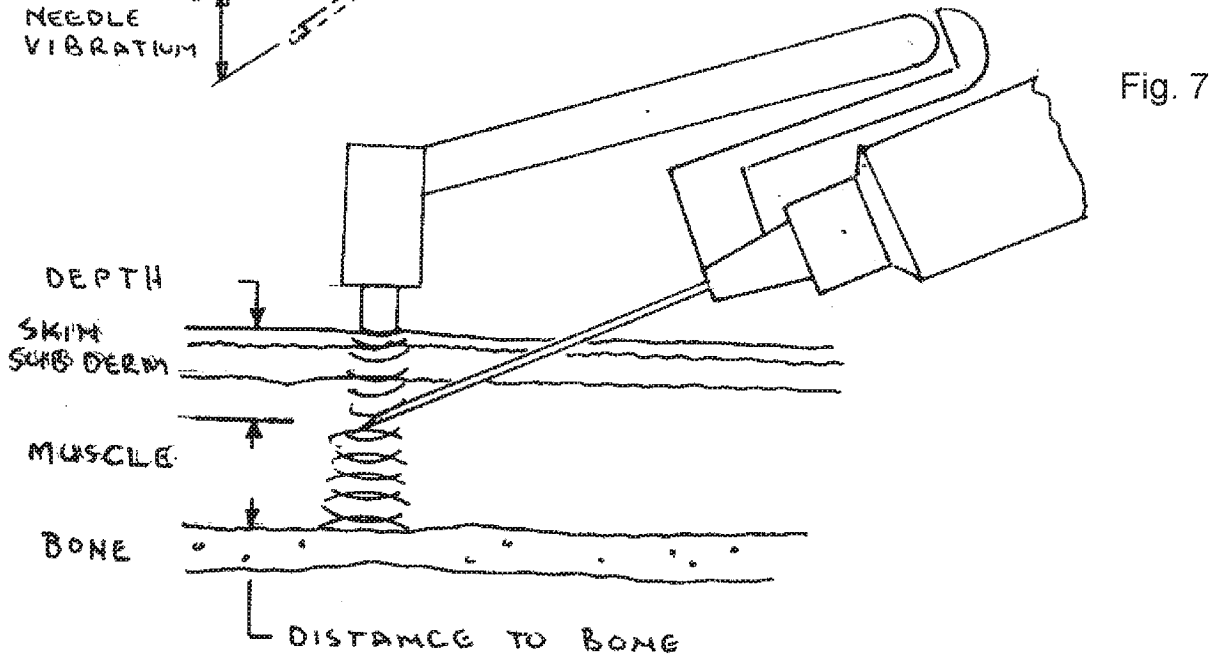
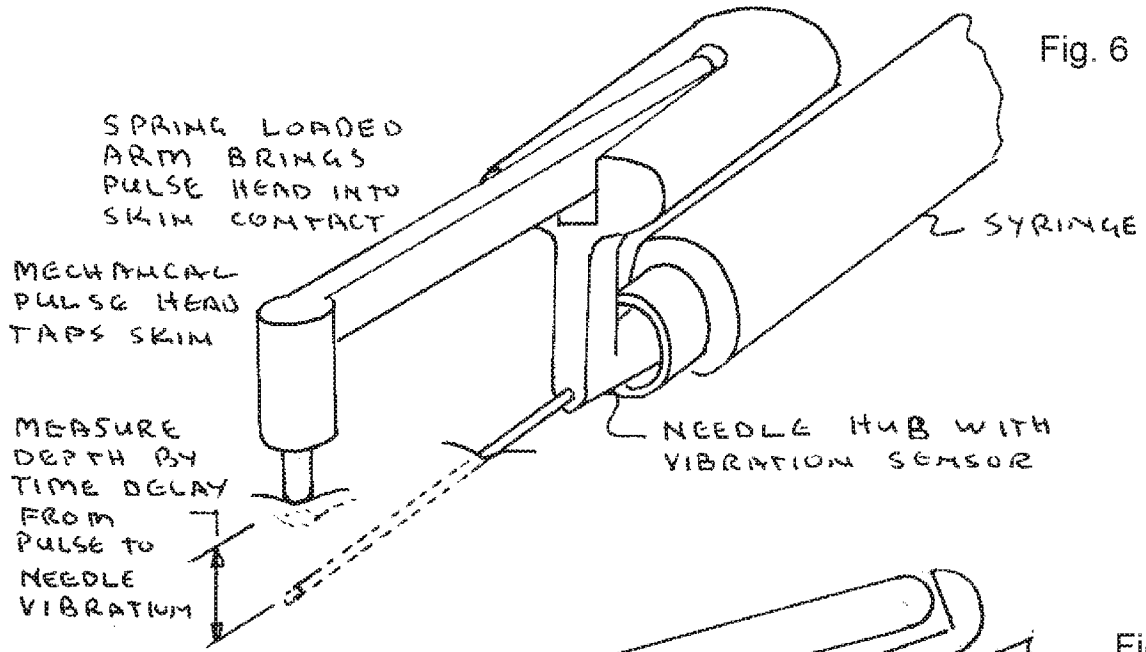

FIG 3





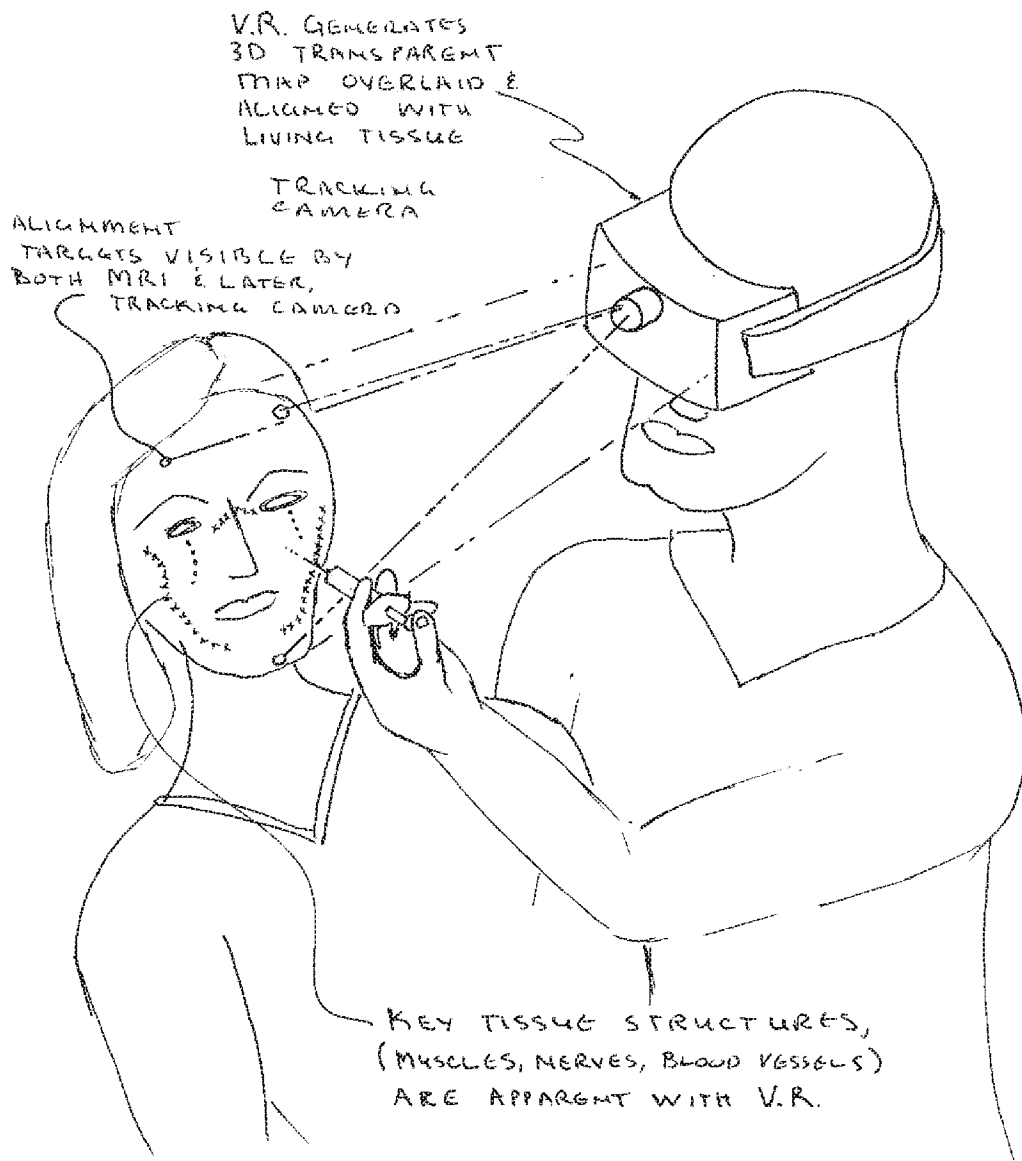

Fig. 8

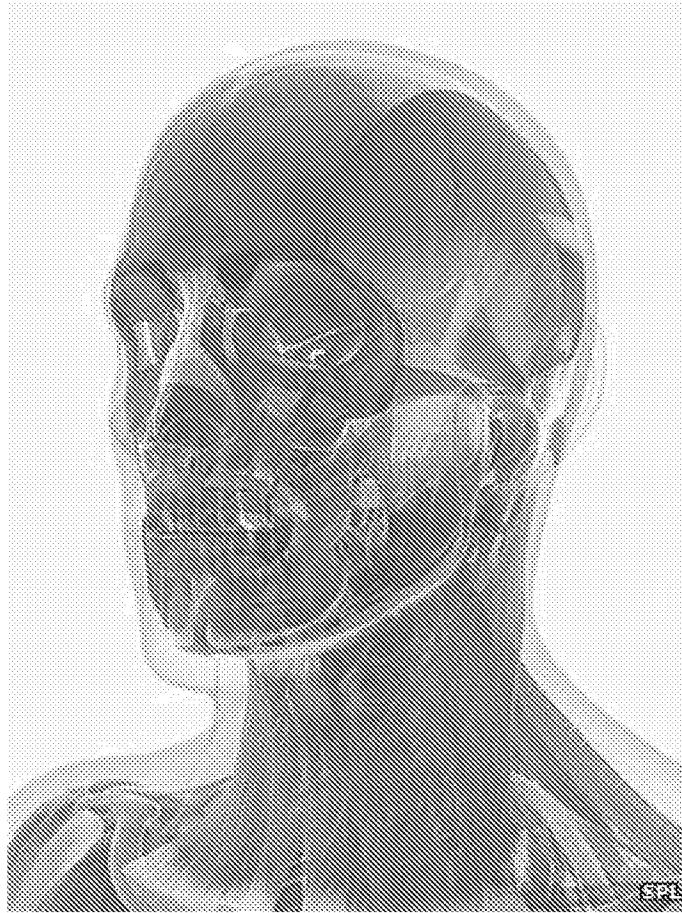

Fig. 9