

(No Model.)

H. PADDOCK.  
WEIGHING SCALE.

No. 521,623.

Patented June 19, 1894.

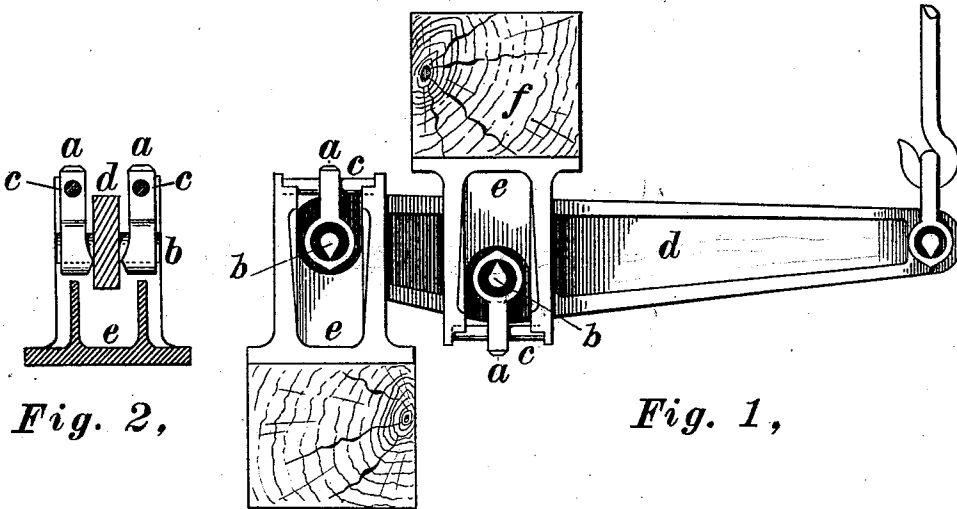

Fig. 2,

Fig. 1,

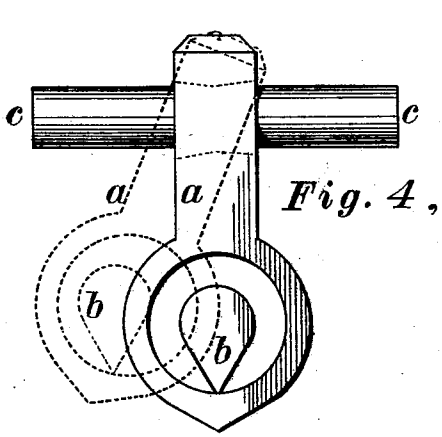

Fig. 4,

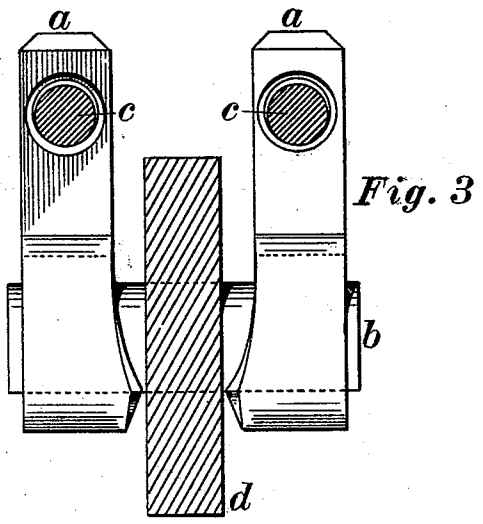

Fig. 3

Witnesses,  
*Wm Spencer,*  
*Saml. C. Tyler.*

Inventor.  
*Harlin Paddock*

# UNITED STATES PATENT OFFICE.

HARVLIN PADDOCK, OF ST. JOHNSBURY, VERMONT, ASSIGNOR TO THE  
E. & T. FAIRBANKS & COMPANY, OF VERMONT.

## WEIGHING-SCALE.

SPECIFICATION forming part of Letters Patent No. 521,623, dated June 19, 1894.

Application filed October 26, 1892. Serial No. 450,084. (No model.)

*To all whom it may concern:*

Be it known that I, HARVLIN PADDOCK, a citizen of the United States, residing at St. Johnsbury, county of Caledonia, State of Vermont, have invented a new and useful Improvement in Weighing-Scales, of which the following is a specification.

My invention consists of a new and improved method of supporting the levers and pivots, and of attaching the platform thereto.

In the drawings, Figure 1. is a side elevation of a scale lever embodying my invention. Fig. 2, is a cross section of the same. Fig. 3 is an enlarged view of Fig. 2; and Fig. 4 is a side view, showing one loop and rod.

Similar letters refer to similar parts throughout the several views.

*d* is a lever in a weighing machine provided with suitable knife edged pivots *b, b*, and on either end of each pivot is a loop or clevis *a*, with the inside of the eye hardened to receive the knife edge of the pivot *b*. The other end of each loop *a*, is provided with a hole through which passes a pin *c*, at right angles to the pivot *b*. Each end of this pin rests in a sinkage in base *e*, but the middle of the rod is free to receive loop *a*. The hole is countersunk on each side of the clevis so as to take a bearing upon the rod only in the middle of the clevis. The loop may then swing as shown in Fig. 4, until the side of this countersunk hole strikes the pin, and it will also swing at right angles to the pin to allow the pivot to take a bearing upon the whole length of the hardened eye of each loop.

It is exceedingly important in a weighing scale that all levers and connections should hang with the utmost freedom from stiffness, and the objects of my invention are, first, to allow loop *a* to swing upon pin *c* as shown by the dotted lines in Fig. 4 and thus avoid rigidity, second, to allow the levers *d* to settle and adapt themselves to free and proper positions, and third, to permit the loop *a* to slide along on the pin *c* to allow for any inaccuracy of work or variation of the material *f* in the scale.

I am aware that scales have been made in which the loop hangs upon a pin parallel to the pivot, so as to allow a certain freedom of motion but differing from my invention in this:—while the loop might swing to some extent, yet its position was fixed, so that it could not slide along to another place. In case the timber should shrink or the castings be sprung, or the work be at all inaccurate the loop could not adjust itself to the varying conditions and the scale would work hard, while my invention as reduced to practice has overcome all these difficulties.

What I claim, therefore, and what I desire to secure by Letters Patent, is embodied in the following claims:

1. In combination with a scale lever, loops having eyes in which the pivots of the lever rest, said loops having openings through them, and rigid horizontal rods *c* passing through said openings and directly supporting said loops whereby said loops are capable of adjustment on said rods, and means for supporting the rods *c*: substantially as described.

2. In combination with a scale lever, having suitable knife edge pivots, loops *a*, having eyes in which the knife edge pivots rest, said loops having openings near their upper ends, horizontal rods passing through said openings, said openings tapering from both sides of the loops toward the center, whereby the loops bear upon the rods only at one point, and are permitted sliding and swinging movement thereon; substantially as described.

3. In a railroad scale, in combination with the timbers *f*, the supporting standards *e*, the rods *c*, rigidly supported on said standards, the lever *d*, with pivots *b*, the loops *a*, having eyes in which the pivots rest, and having openings at their opposite ends through which the rods *c*, pass, said openings being formed to give the loops a limited sliding movement on said rods; substantially as described.

HARVLIN PADDOCK.

Witnesses:

C. M. SPENCER,  
WM. C. TYLER.