

Jan. 16, 1940.

H. REICHERT

2,187,628

SIGNALING AND ALARM DEVICE

Filed July 21, 1938

2 Sheets-Sheet 1

Fig. 1

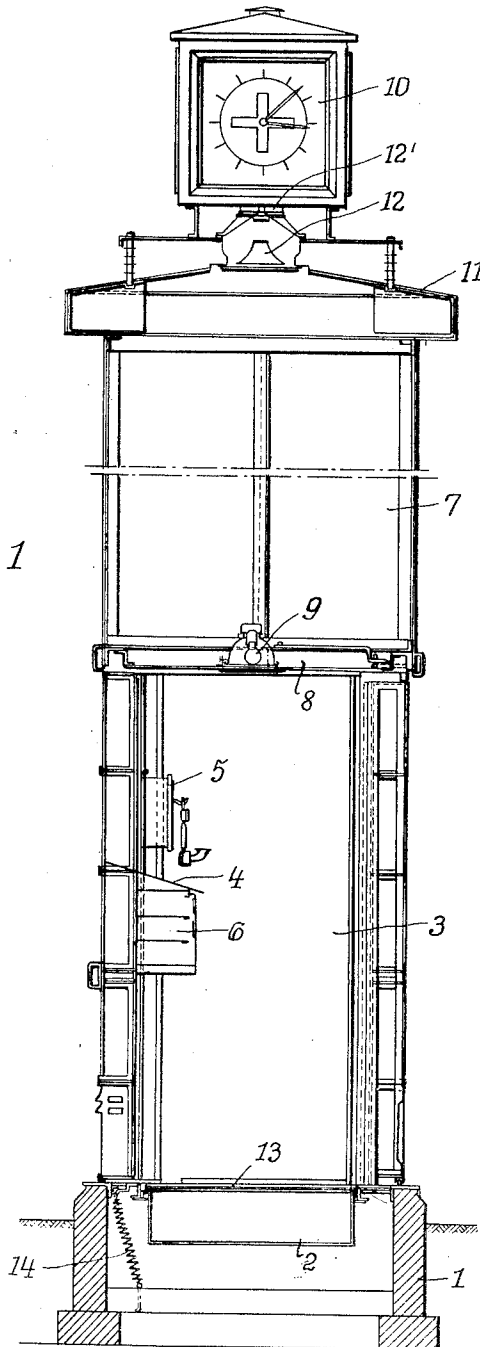

Inventor:

Hans Reichert,
by Kimmel & Crowell,
Attorneys.

Jan. 16, 1940.

H. REICHERT

2,187,628

SIGNALING AND ALARM DEVICE

Filed July 21, 1938

2 Sheets-Sheet 2

Fig. 2

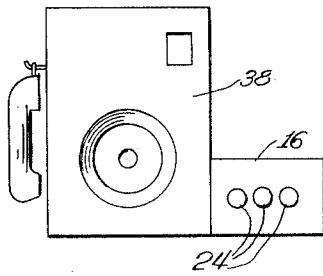

Fig. 4

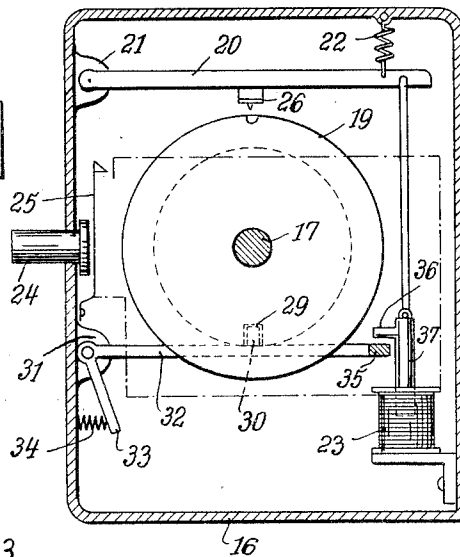
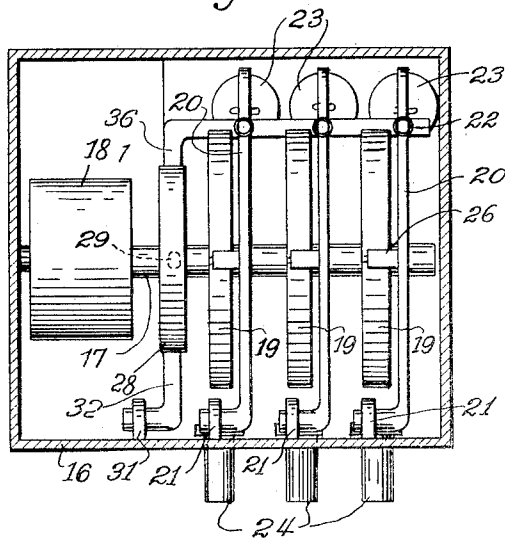

Fig. 3



Inventor:

Hans Reichert,

by Kimmel & Crowell,
Attorneys.

UNITED STATES PATENT OFFICE

2,187,628

SIGNALING AND ALARM DEVICE

Hans Reichert, Berlin, Germany

Application July 21, 1938, Serial No. 220,568
In Germany April 18, 1936

2 Claims. (Cl. 179—5)

This invention relates to installations or apparatus for announcing, giving alarm, signaling, obtaining assistance in the case of accidents, and the like. The arrangement according to the invention may be provided independently or in combination with structures which are found in streets and which are in the form of columns, and may be combined with telephone kiosks, automatic telephones, clock standards and the like.

The invention is intended more particularly to include a call device for coin-box telephones with a selective device for directly calling for example the fire brigade, the police, and assistance in case of accidents. According to the invention the call device is so constructed that the call can be completed rapidly and without preliminary operation, that is, more particularly without actuating the usual dial and without inserting a coin. The arrangement can be attached to any coin-box telephone with a small amount of work and expense, so that it is possible considerably to increase the number of existing call stations and to simplify reaching these stations.

The invention also includes a public call or first-aid device which, according to the invention, is so arranged that the actuation or use or preparation of the arrangements causes an optical and/or acoustic signal to be given at or near the location of the device.

Constructional examples and further details of the invention will be explained in the following description with reference to the accompanying drawings.

In the drawings:

Figure 1 is a front elevation partly in section of a street column including a coin box telephone with which a direct call device, in accordance with this invention is to be attached,

Figure 2 is a front elevation of a coin box telephone showing the adaptation therewith of a direct call device in accordance with this invention,

Figure 3 is a vertical sectional view, upon an enlarged scale of the call device, in accordance with this invention, and

Figure 4 is a sectional plan of the housing of the device and further showing the elements of the device in top plan.

As already mentioned, the device according to the invention can be provided in a street construction in the form of a column, as illustrated by way of example in Figure 1. This however, is not absolutely necessary. In case of necessity these arrangements may be provided, for ex-

ample, independently of one another or also in part combination or all together at points of heavy traffic, in places where there is danger from traffic, in public places, business houses, warehouses and so forth. Consequently the following description of the column-like street structure is to be regarded only as an example.

The column, which is preferably of circular cross-section and preferably is fitted with a suitably constructed sliding door, stands on a base 1 which also contains a separate closed compartment 2 so that this compartment may contain first-aid appliances, for example, a preferably folded stretcher. The space 3 above this serves for receiving various appliances which are important for public purposes, for example, as a telephone kiosk. Accordingly a table 4 for the telephone directory is provided. Above or beside this is a telephone 5 which, for example, may be constructed as an automatic telephone with coin box. The space under the telephone directory is preferably used as a cupboard 6 for medical goods.

The column further has a structure 7 which is divided by a partition 8 from the space which is designated as a telephone kiosk. In this case the partition has an illuminating device 9 in the form of an electric lamp or the like. The structure 7 serves mainly for carrying advertisements (luminous advertisements, posters, moving-picture advertisements and so forth). At the top is a structure 10 which may contain a clock and also can be fitted with a sound-producing device, for example in such a manner that the upper cover 11 of the structure serves simultaneously as a sound-radiating surface for the sound producing device (alarm bell) 12 or the loud speaker 12'. In cases where the advertising structure 7 is dispensed with, the above described structure is placed directly over the partition 8. Above the partition 8 are the internally operated appliances for the column-like structure, for example, door closing devices, central clock, transformers, fuses and the like.

Preferably the construction is made such that on the operation of an alarm or call device the flap 13 which closes the compartment for receiving the structure opens automatically under the influence of a spring 14. At the same time in this case preferably also the medical cupboard is opened in a similar manner, preferably using electrical released locking devices. The manner of operation of sending out a call will be seen from the following description of Figures 2-4 which show the devices in question.

In the casing 16 a horizontal shaft 17 is mounted which is driven by a motor 18 of any desired kind (electric motor, clockwork or the like).

5 On this shaft 17 three current impulse discs 19 are secured which in a known manner are provided with recesses at the edges corresponding to the connection to be established, the current impulses of which can be taken off by means of the contact arms 20 which are rotatably mounted on the casing wall in the bearing 21. By means of the springs 22 these contact arms in the position of rest are drawn away from the periphery of the corresponding impulse discs 19. At the same time they can each be drawn against the discs 19 by electromagnets 23 when, by means of an outwardly projecting contact button 24 and a contact arm 25, a current circuit (shown in broken lines) connected with a suitable current source, is closed. In this way each contact pin 26 is drawn against the corresponding disc 19.

Further, a locking disc 28 is mounted on the shaft 17 which is provided with a locking groove 29. In the rest position this groove 29 is engaged by a locking pin 30 which is mounted on a lever 32 rotatably mounted in the bearing 31, which lever lies under the locking disc 28 and is pressed upwardly against the disc 28 by a compression spring 34 acting upon an extension arm 33. The free end of the lever 32 is bent at about a right-angle to an arm 35 extending parallel to the shaft 17 which passes close beneath the lugs 36, one of which is provided on each armature 37 of the three electromagnets 23.

35 The mode of operation is as follows:

Each of the knobs 24 is intended for a definite connection and is suitably marked, thus for example, "Police", "Accidents", "Fire". When the corresponding button 24 is pressed, the circuit to the corresponding electromagnet 23 is closed by the contact 25 so that the corresponding armature is drawn into the coil. By this means, on the one hand the corresponding contact arm 20, 26 is placed against the corresponding impulse disc 19, and, on the other hand, by means of the lug 36 and the arm 35, 32 the locking pin 30 is drawn out of the groove 29 so that the motor 18 can drive the shaft 17 and with it the impulse discs 19, of which however, only the one whose contact arm is pressed against it can operate it and send out impulses. By means of a separate contact arrangement it is possible to provide that at any time only one disc 19 will operate, for example by causing the circuits of the other contact arms to be interrupted as soon as one contact arm is attracted. This prevents the incorrect connection being obtained by the operation of more than one impulse disc.

As long as the shaft 17 rotates the pin 30 slides on the periphery of the disc 28 and when this has performed a complete revolution the lug 30 again falls into the groove 29 and stops the drive, whereby the part returns to the initial position under the action of the springs 22 and 34.

65 From Figure 2 it will be seen that this installation can be added without difficulty to any coin-box telephone. In some cases it is sufficient to provide the press buttons 24 on or beside the coin-box telephone 33, while the other arrangement can be provided at any desired other place and simply connected with the buttons by conductors. In this case it is then also possible instead of the pressure-actuating contact buttons 24 to use a disc similar to the ordinary dial and to arrange it on the same shaft as the existing

dial, in which case the only difference from the ordinary dial will be that for obtaining the desired connection a repeated rotation will not be necessary, but only a single rotation through a given angle, where the current impulse device will be set in operation. It may be of advantage to provide a further contact device in combination with the locking pin 32 by which, when the call device is actuated, any conversation being carried on over the coin-box telephone will be immediately interrupted so that the connection with the desired point will actually be made immediately possible.

The connection of this call device is effected in such a manner that the connection is effected through the coin-box telephone without the insertion of a coin. For this purpose it is necessary to lay the conductors in such a manner that the coin lock is avoided or to effect a cutting out of the coin lock by means of a separate contact which may also be attached to the locking pin 32.

In order to protect the devices against misuse in a simple and effective manner in order to ensure that in cases of accidents of any kind a police official or a person qualified to give assistance will rapidly reach the place of the accident and finally to prevent misuse of the accident and first-aid appliances, a further feature of the invention consists in this, that by the actuation or use or preparation of the call device an optical and/or acoustic signal is automatically given at or near to the location of the device.

If the call device consists, for example of contact devices to be actuated by press buttons or the like and connected to one or more signal conductors, it is quite simple by means of the same or other coupled contact devices also to close the circuit for the signal which is to be given at or near the location of the device. It is however, also possible to cause the signal to be given at the location of the device in a mechanical manner on the actuation of the device, for example, by the contact buttons of the call device being coupled mechanically with the operating member of a signaling device. This inventive idea can naturally likewise be used with the devices described above, more particularly in combination with the column-like street structure according to Figure 1. Thus in this case the giving of the signal at the location of the device can be effected by an electrical signaling circuit being closed or by the signal being set in operation mechanically on the opening of the receptacle for the rescue appliances. The signaling device may be optical or acoustic appliances provided on the column (loud-speakers, horns, alarm bells, sirens or the like).

In the construction of the arrangement according to the invention importance is attached principally to ensuring reliability. Consequently the devices should be enclosed in a weatherproof manner. The conductors are provided in hollow spaces in the constructional parts. The sound producing device is well protected within the clock case or the upper cover and so forth. Where electrical synchronous clocks are used the installation can be constructed in such a manner that in a place which is not open to public traffic, for example, in a hotel or a tobacco shop, a motor clock is provided which is under constant observation and is well protected from atmospheric noises and so forth, and thus from this main clock, the clocks provided for example in columns, can be controlled. It may again be mentioned

that the above described devices can also be provided independently of one another. This applies more particularly to the proposal for making the actuation of the locking means for the accident and first-aid appliances dependent upon the signaling device.

I claim:

1. In a direct call device for attachment to a telephone in independent relation with respect to the dial and coin box of the telephone, said device including a normally locked revoluble motor driven shaft, a current impulse disc bodily carried by said shaft and having its edge formed with a recess corresponding to a connection for the direct call, a spring controlled impulse current take-off arm arranged adjacent to and spaced from said disk, said arm being pivoted at one end and formed intermediate its ends with a laterally disposed contact overhanging and normally disposed in spaced relation to the edge of said disk and for correlation with said edge and recess, a shaft locking disc bodily carried by the shaft and formed with a groove in its edge, a spring controlled pivoted shaft locking structure including a locking pin disposed to ride against the edge of and normally engaging in the groove of said locking disc for locking the shaft from revolving, a magnet interposed in a normally opened circuit and having its armature connected to the other end of said arm and provided with releasable means for and normally spaced from said structure, and a call designated normally inactive circuit closing device interposed in said circuit and provided when active for closing the latter for energizing said magnet whereby the armature of the latter will be moved in a direction to simultaneously shift said arm to move said contact in coacting relation with respect to said disc and the releasing means on the armature to an extent to move said pin out of the groove in the locking disc to permit of revolving of the shaft so as to provide for said contact and

impulse disc to establish the connection for the call.

2. In a direct call device for attachment to a telephone in independent relation with respect to the dial and coin box of the telephone, said device including a normally locked revoluble motor driven shaft, a plurality of parallel spaced current impulse discs bodily carried by said shaft and having their edges provided with recesses corresponding to the connections to be established for the calls, a plurality of arms for taking off the current impulses from said discs formed with contacts for correlation with the edges of said discs and said recesses, said arms being spring controlled, pivoted at one end and having the contacts thereof normally clear of said discs, a shaft locking disc bodily carried by the shaft and formed with a groove in its edge, a pivotally mounted spring controlled shaft locking structure including a locking pin for riding against the edge of a locking disc and normally engaging in said groove for locking the shaft from revolving, a plurality of magnets interposed in normally opened circuits and having armatures connected to the other ends of said arms provided with releasing means common to said structure, and a plurality of independent different call designated selectively operated normally inactive circuit closing devices interposed in said circuits and each provided when active for closing a magnet circuit to energize a magnet whereby the armature of the latter will be moved in a direction to simultaneously shift the arm connected thereto to move the contact on such arm in coacting relation with respect to an impulse disc and for moving the releasing means on such armature to an extent to move said locking pin out of the groove in the locking disc to permit of the revolving of the shaft so as to provide for the coacting contact and impulse disc to establish a connection for a call.

HANS REICHERT.