

*A. Underwood,  
Making Matches,*

*No. 14,782,*

*Patented Apr. 29, 1856.*

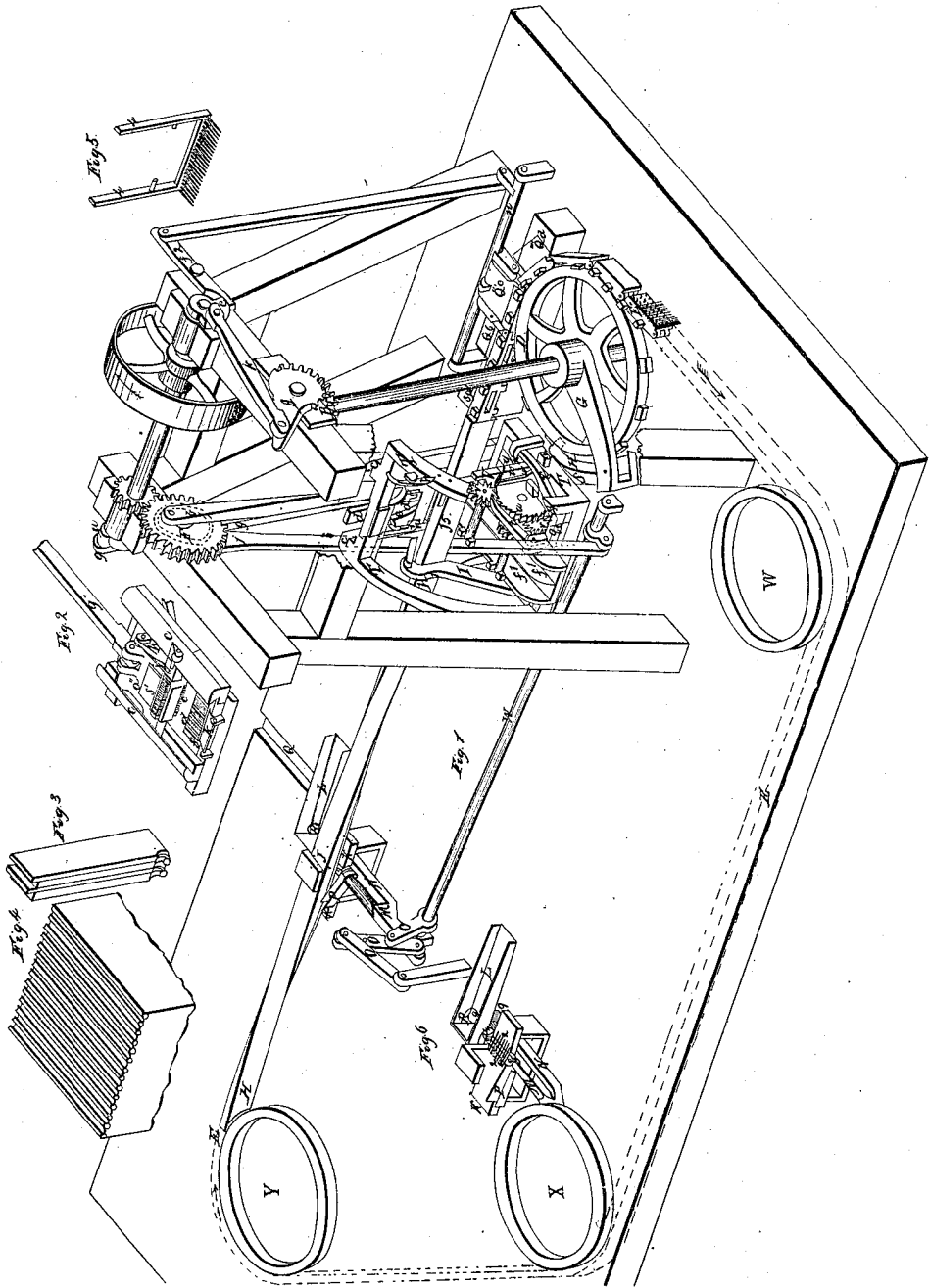

# UNITED STATES PATENT OFFICE.

ALEXANDER UNDERWOOD, OF ILION, NEW YORK.

MACHINE FOR MANUFACTURING FRICTION-MATCHES.

Specification of Letters Patent No. 14,782, dated April 29, 1856.

To all whom it may concern:

Be it known that I, ALEXANDER UNDERWOOD, of the town of Ilion, county of Herkimer, State of New York, have invented a new and Improved Machine or Combination of Machinery for Cutting the Sticks, Racking, Dipping, and Boxing Friction-Matches; and I do hereby declare that the following is a full, clear, and exact description of the construction and operation of the same, reference being had to the annexed drawings, making a part of this specification, in which—

Figure 1, is a perspective view of the combination: Fig. 2, is a perspective view of the front of the cutting and racking machine T, T, T: Fig. 3, is a full size view of the cutting tools or dies and intermediate plates of metal, Fig. 4, shows the block of wood, and the operation of the tools or dies upon it; Fig. 5, is a comb for regulating the sticks while they are being pressed on the racks. Fig. 6 represents the boxing part of the machine detached, showing the slotted or tubulated table K, K, the box trough or hopper L, the top or cap trough P, the filling piston device M, N, the finger or forked device 2, 2, for detaching the matches from the racks, the flexible, or elastic, split tubing 4, 4, the tube or band 9 to receive the boxes when filled.

In order to describe my invention more fully, I construct a frame, shaft and driving pulley shown Fig. 1. Directly under said shaft I place the machine Fig. 2, and T, T, T, Fig. 1, for cutting the sticks and pressing them on the racks. The spur wheel F, Fig. 1, serves as a crank, being connected by the rod *b*, to the slide *u* in which are two double inclined planes *w* and *x*. By the downward and upward movement of the slide *v*, the plane *w* is made to operate the horizontal slide *z* which works the levers *y*, *y*, and shifts or moves the feeding box sidewise alternately the distance of the diameter of the orifice in the tools or dies. At the same time, while the tools are farthest back from the block, the inclined plane *x* moves the slide *r* which operates the rocking shaft *g*, the dog *t*, the ratchet wheel *u*, spur wheels *v*, *v*, *v*, *v*, which are kyeed on the end of the fluted pressure rollers &c. There are other rollers directly under them, which indenting themselves in the ends of the grain of the blocks of wood, move the blocks which are placed in the box *f*, *f*, Fig.

1, forward to the tools the distance of one half the diameter of the orifice in the dies, thus causing the dies to cut the sticks from the block as represented in Fig. 4, the tools or dies cutting the sticks smooth and readily from the block, wasting the least possible amount of wood.

*g*, *g*, Figs. 1, and 2, show the rod connecting the cross-heads *a*, *a*, with the crank V; *e*, *e*, *e''*, *e''*, the ways; *f*, *f*, *f*, the box in which the blocks of wood are fed to the tools or dies.

*b*, Fig. 2, is the tool or die stock; *e*, *e*, the tools or dies; *d*, the block from which the sticks are cut.

K, is a scraper intended to catch and hold the shaving or fiber of wood from being drawn back by the dies, which would otherwise clog them up.

*h*, *h*, *h*, Figs. 1, and 2, indicate the moving inclined planes which pass under the fins on each side of the press plate *d*, Fig. 1, and the pin in the slide *i*, *i*, Figs. 1, and 2.

Fig. 5 is a comb suspended from the top of the frame T, T, T, by the bars 4, 4, so that when the tools are farthest back from the block, the teeth of the comb are thrown out between the supply of match sticks formed by the previous cut, and this supply of sticks remaining in the dies, until the dies enter the block and force them out.

By the operation of the inclined planes above described, the rack E, arranged in the ways J, is drawn diagonally downward toward the blocks and crosshead, while the press plate is thrown out. The bars (marked 3) bear against the sticks and press them on the racks the instant they leave the dies, and the rack and the press plate are thrown back to their standing positions by the springs *e* and *g*. The crank *e* being connected to the bevel gear A, by means of the rod K, works the bevel gear B, attached to the vertical shaft *w*, which, together with the arm G, dog H, and spring S, move the loose cog wheel D, which operation also actuates the endless chain racks causing them to move around support pulleys, or, carrier wheels, similar to the arrangement indicated by the letters *w*, *x*, *y*. Each of these links are formed with rows or series of pins, inserted as shown at E, which are designed to hold the match sticks, and as the endless chain of racks moves around, each link or rack in regular progress presses immediately over the several dipping pans, repre-

sent by the letters *ga*, *gb*, *gc*, *gd*, and owing to the remittent motion of the endless chain racks, each rack with stick is thereby permitted to be pressed downward into each  
 5 pan to be dipped which operation of dipping, is brought about, by the cam C, attached to the crank C<sup>x</sup>, which striking the lever *f* attached to the pitman rod *m* works the rocking shaft *n*. The motion of the  
 10 rocking shaft *n*, causes the dipping pan *gc*, to rise upward toward the lower ends of the match sticks, which dip successively into the hot sand bath, or on a hot metallic plate at *gd*, then into the sulfur bath *gb*, next into  
 15 the igniting, or fulminating compound vat *gc*, and lastly into the coloring fluid in the coating bath *gd*. The pan *gc* drops from the sticks and remains there while the chain moves forward.

20 J is the guide trough or way through which the chain passes, twisting from a vertical position at H, to a horizontal position at I, and back to a vertical position again at K, 1.

25 K, K, Fig. 6 is a metallic stand, across the top plate, is a cavity, or trough 4, 4 into which I insert a tube lined with india rubber or any other elastic substance that will contract to the size of the inside of a  
 30 match box and expand to the size of the outside of the cover as it is forced through it, there being a slit in the upper side of the tube its entire length and large enough to admit the matches into said tube sidewise  
 35 as they are taken from the racks by the scraper 2, as the racks pass over it.

P, Fig. 1, is the hopper into which the covers are placed.

40 L is the hopper in which the boxes are placed.

R is the orifice through which the boxes pass when filled into a tube or band 9 Fig. 6 hung to the bottom of said orifice.

45 Q is the spout or endless apron for conveying the boxes from the machine.

In the back part of the spur wheel F, Fig. 1, is a cam indicated by the double row of dots on the spur wheel F, formed by a groove or gutter in the form of the letter V, operating a follower pin projecting from,  
 50 and near the end of the rod J J which works the rocking shaft *w*, and levers *o*, *o*, *o*, the piston *m* and bar N. A box cover being in the hopper in front of the packing piston and the matches in the tube, the piston M  
 55 Fig. 6 forces the covers on to the dipped ends of the matches and forcing them into

the box, and in doing this, adjusting the cover on the box, (the tube expanding only  
 60 as the cover passes through it, and then contracting) while the box of matches pass into the tube back of R, which is raised to a horizontal position to receive it, by the bar N, which bar at the same time moves the  
 65 apron or cam Q, forward with the boxes on it, thus each box is filled and carried off. As the piston and bar are withdrawn said table swings down and drops the box on the  
 70 apron, and another box and cover rolls down in a line with the tube in the stand. When the matches do not become sufficiently dry to be covered in the boxes when they arrive at the boxing machine, I use (instead of the  
 75 elastic tube in the stand) a plain metallic tube which is the size and shape of the inside of the match box; when this occurs I omit the covers, and shorten the stroke of the piston, by connecting the jointed levers  
 80 by the upper pin, as shown at O, O, O, Fig. 1.

Having fully and clearly described my automatic, friction match making machine what I claim as new and original with myself, and desire to secure by Letters Patent  
 85 of the United States is as follows:

1. I claim the cutting and racking device T, T, T formed of the several parts or elements *b*, *c*, *c*, *d*, *d*, *e*, *e*, *f*<sup>1</sup>, *f*<sup>1</sup>, *g*, *gh*, as described, and as fully shown in Figs. 2, and 5.

2. I claim the manner or mode of feeding  
 90 the blocks or billets of wood to the cutters by the alternate lateral shifting motion, the box *f*<sup>1</sup>, *f*<sup>1</sup> caused through the intervention of the devices *b*, *j*, *j*, *q*<sup>1</sup>, *q*<sup>2</sup>, *r*, *u*, *v*, *w*, *y*, *y*, combined with the fluted rollers, &c., substantially  
 95 as described and as shown in Fig. 1.

3. I also claim the toothed or geared reciprocating crank device A, with the combination parts *c*, *c*<sup>x</sup>, *f*<sup>2</sup>, *k*, *m*, *n*, and the dipping pan *gc*, substantially as set and as represented in Fig. 1.  
 100

4. I claim the construction of the endless chain rack, devices, formed with series of pins or teeth as at E, together in combination with the intermittent, rotary, rack carrier D, and crank ratchet device G, H, used and operated substantially as described.  
 105

5. I claim the boxing and capping device K, K, L M N, *o*, *o*, *o*, P, R, W, 2, 2, 4, 4, 9, 9, as described and as shown in Fig. 6.

ALEXANDER UNDERWOOD.

Witnesses:

HIRAM STELRUS,

CATHERINE M. REMINGTON.