

(12) STANDARD PATENT APPLICATION (11) Application No. AU 2019201033 A1
(19) AUSTRALIAN PATENT OFFICE

(54) Title
Surgical buttresses for surgical stapling apparatus

(51) International Patent Classification(s)
A61B 17/072 (2006.01)

(21) Application No: **2019201033** (22) Date of Filing: **2019.02.14**

(30) Priority Data

(31) Number	(32) Date	(33) Country
16/265,299	2019.02.01	US
62/633,747	2018.02.22	US

(43) Publication Date: **2019.09.05**

(43) Publication Journal Date: **2019.09.05**

(71) Applicant(s)
Covidien LP

(72) Inventor(s)
SHANKARSETTY, Jeevan Maddur;KALEPU, Hari Naga Mahesh;SRINIVAS, Jitendra Bhargava

(74) Agent / Attorney
Spruson & Ferguson, GPO Box 3898, Sydney, NSW, 2001, AU

SURGICAL BUTTRESSES FOR SURGICAL STAPLING APPARATUS

ABSTRACT

A surgical stapling apparatus (1) comprising: an end effector (30) having an anvil assembly (40) and a staple cartridge assembly (50); and an anvil buttress retention system (240) releasably disposed on the anvil assembly (40), the anvil buttress retention system (240) including an anvil buttress (210) and a retention member (130) including an elongated body looped around at least a portion of the anvil buttress (210) with a free end of the elongated body extendable through a looped end of the elongated body in an untightened configuration such that the anvil buttress retention system (240) is slidable relative to the anvil assembly (40), the free end of the retention member (130) movable relative to and through the looped end to a tightened configuration to secure the anvil buttress retention system (240) to the anvil assembly (40).

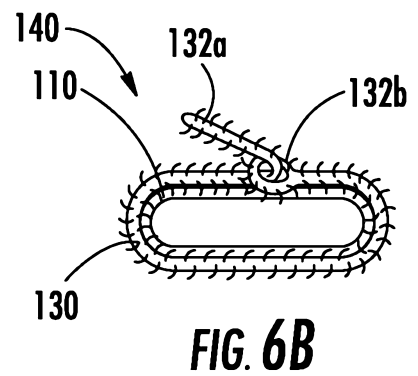
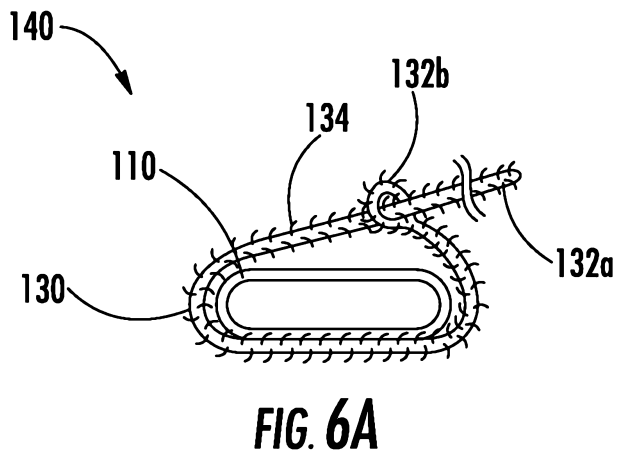
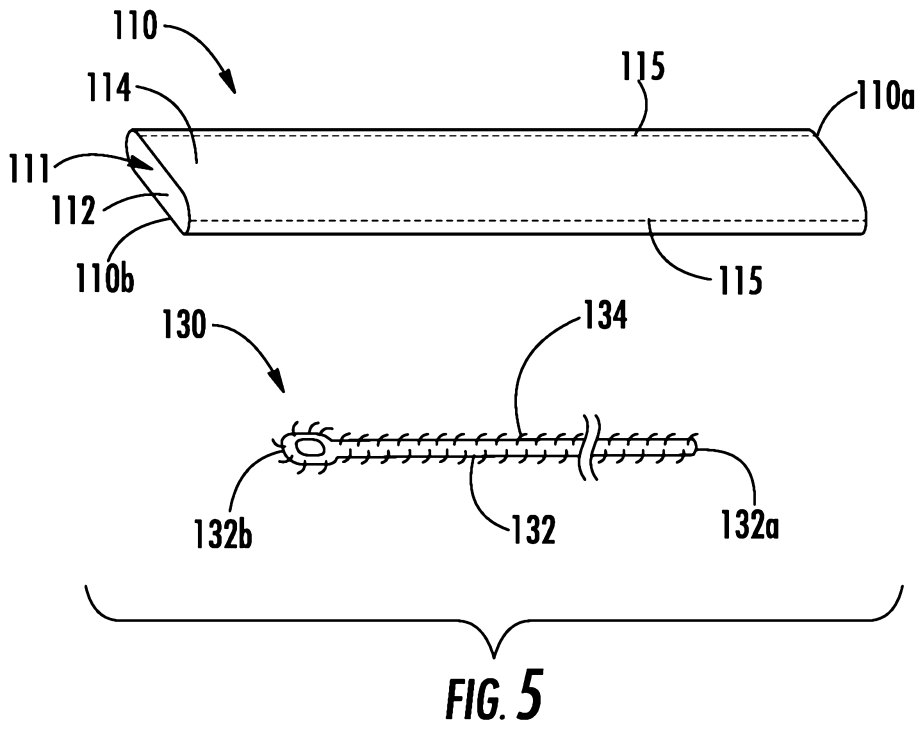
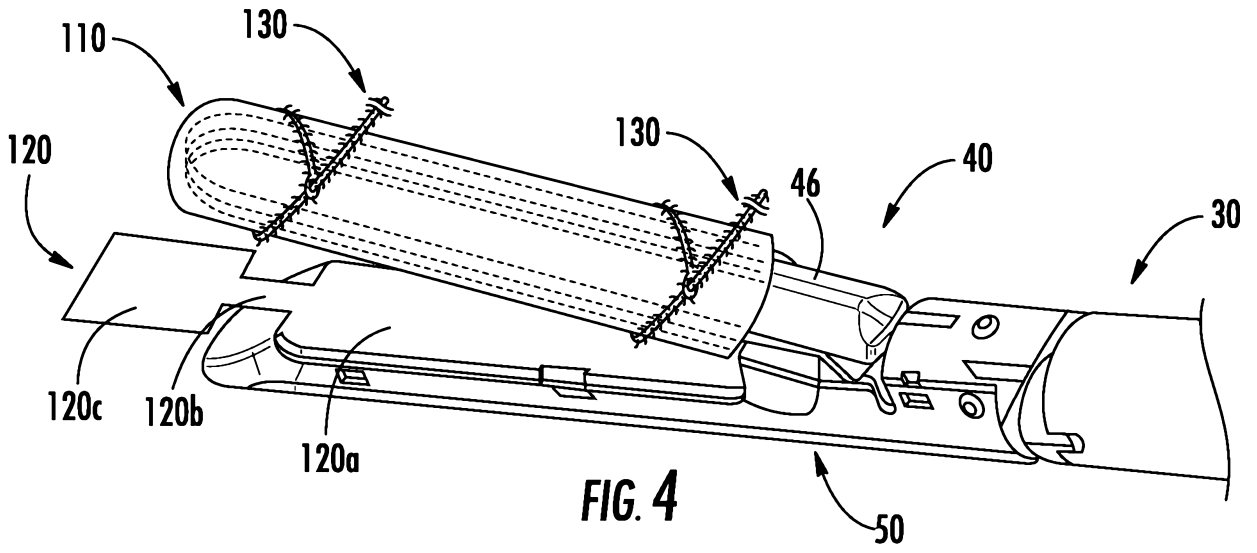

SURGICAL BUTTRESSES FOR SURGICAL STAPLING APPARATUS

CROSS-REFERENCE TO RELATED APPLICATIONS

[0001] This application claims the benefit of and priority to U.S. Provisional Patent Application No. 62/633,747 filed February 22, 2018, and U.S. Patent Application No. 16/265,299 filed February 1, 2019, the entire disclosures of which are incorporated by reference herein.

BACKGROUND

Technical Field

[0002] The present disclosure relates to surgical buttresses for use with surgical stapling apparatus, and more particularly, to surgical buttresses that are releasably attached to the surgical stapling apparatus.

Background of Related Art

[0003] Surgical stapling apparatus are employed by surgeons to sequentially or simultaneously apply one or more rows of fasteners, e.g., staples or two-part fasteners, to body tissue for the purpose of joining segments of body tissue together. Such apparatus generally include a pair of jaws or finger-like structures between which the body tissue to be joined is placed. When the surgical stapling apparatus is actuated, or “fired”, longitudinally moving firing bars contact staple drive members in one of the jaws. The staple drive members push the surgical staples through the body tissue and into an anvil in the opposite jaw which forms the staples. If body tissue is to be removed or separated, a knife blade can be provided in the jaws of the apparatus to cut the body tissue between the lines of staples.

[0004] Surgical supports, e.g., meshes or buttress materials, may be used in combination with surgical stapling apparatus to bridge, repair, and/or reinforce tissue defects within a patient such as those occurring, for example, in the abdominal wall, chest wall, diaphragm, or musculo-aponeurotic areas of the body. The buttress material reinforces the staple or suture line as well as covers the juncture of the tissues to reduce leakage prior to healing.

SUMMARY

[0005] According to an aspect of the present disclosure, a surgical stapling apparatus includes an end effector having an anvil assembly and a staple cartridge assembly, and an anvil buttress retention system releasably disposed on the anvil assembly. The anvil buttress retention system includes an anvil buttress and a retention member including an elongated body looped around at least a portion of the anvil buttress with a free end of the elongated body extendable through a looped end of the elongated body in an untightened configuration such that the anvil buttress retention system is slidable relative to the anvil assembly. The free end of the retention member is movable relative to and through the looped end to a tightened configuration to secure the anvil buttress retention system to the anvil assembly.

[0006] The retention member may include a plurality of barbs extending from the elongated body. The retention member may extend across a central longitudinal slot of the anvil assembly. The retention member may be a first retention member, and the anvil buttress retention assembly may further include a second retention member disposed in spaced relation relative to the first retention member along a length of the anvil buttress.

[0007] In embodiments, the anvil buttress is a sleeve defining a cavity therein that is configured to receive the anvil assembly. In some embodiments, the sleeve includes a first layer positionable adjacent a tissue facing surface of the anvil assembly and a second layer positionable adjacent an outwardly facing surface of the anvil assembly. In certain embodiments, the sleeve includes perforations extending along a length thereof and positioned between the first and second layers.

[0008] In embodiments, the anvil buttress includes a central portion and a pair of wings extending from the central portion to define a u-shaped channel configured to receive the anvil assembly therein. In some embodiments, the retention member is looped through side edges of the central portion and extends adjacent inner surfaces of the pair of wings such that the free and looped ends are disposed above the u-shaped channel of the anvil buttress.

[0009] The surgical stapling apparatus may further include a cartridge buttress releasably disposed on the staple cartridge assembly of the end effector.

[0010] In embodiments, a method of loading the anvil buttress onto the end effector of the surgical stapling apparatus includes: sliding the anvil buttress of the anvil buttress retention system onto the anvil assembly of the end effector with the retention member in the untightened configuration; and pulling the free end of the retention member relative to and through the looped end to the tightened configuration.

[0011] According to another aspect of the present disclosure, a surgical stapling apparatus includes an end effector having an anvil assembly and a staple cartridge assembly, and an anvil buttress retention system releasably disposed on the anvil assembly. The anvil buttress retention system includes an anvil buttress, an adhesive layer disposed on an anvil facing surface of the anvil buttress, and a porous layer releasably disposed on a tissue facing surface of the anvil buttress. The surgical stapling apparatus may further include a cartridge buttress interconnected with the anvil buttress by a connecting member.

[0012] In embodiments, a method of loading the anvil buttress onto the end effector of the surgical stapling apparatus includes: positioning the adhesive layer of the anvil buttress retention system against a tissue facing surface of the anvil assembly; clamping the end effector such that the porous layer is compressed between the anvil and staple cartridge assemblies to secure the adhesive layer to the anvil assembly; unclamping the end effector; and removing the porous layer from the anvil buttress.

[0013] According to yet another aspect of the present disclosure, a surgical stapling apparatus includes an end effector having an anvil assembly and a staple cartridge assembly, and an anvil buttress retention system releasably disposed on the anvil assembly. The anvil assembly includes an anvil plate including a central longitudinal slot, a cover plate disposed over the anvil plate, and a proximally tapering passage disposed between the anvil plate and the cover plate. The anvil buttress retention system includes an anvil buttress and a tab extending proximally from a distal end of the anvil buttress. The tab is positioned within the proximally tapering passage of the anvil assembly such that a proximal portion of the tab is disposed adjacent the central longitudinal slot of the anvil plate. The tab may include an aperture configured to capture a portion of the anvil assembly therein.

[0014] The surgical stapling apparatus may further include a cartridge buttress connected to the anvil buttress by a connecting member to form a surgical buttress assembly having a

substantially z-shaped configuration. In some embodiments, the connecting member includes a notch formed therein that is aligned with the central longitudinal slot of the anvil plate. The cartridge buttress may be releasably secured to the staple cartridge assembly by sutures.

[0015] In embodiments, a method of loading the anvil buttress onto the end effector of the surgical stapling apparatus includes: positioning the anvil buttress of the anvil buttress retention system against a tissue facing surface of the anvil assembly; and passing the tab through the proximally tapering passage of the anvil assembly to secure the proximal portion of the tab adjacent the central longitudinal slot of the anvil plate.

[0016] Other aspects, features, and advantages will be apparent from the description, drawings, and the claims.

BRIEF DESCRIPTION OF THE DRAWINGS

[0017] Various aspects of the present disclosure are described herein below with reference to the drawings, which are incorporated in and constitute a part of this specification, wherein:

[0018] FIG. 1 is a perspective view of a surgical stapling apparatus in accordance with an embodiment of the present disclosure;

[0019] FIG. 2 is an exploded, perspective view of anvil and cartridge assemblies of a jaw assembly of the surgical stapling apparatus of FIG. 1;

[0020] FIG. 3 is a bottom, perspective view of the anvil assembly of FIGS. 1 and 2;

[0021] FIG. 4 is a perspective view of the jaw assembly of FIG. 1, including anvil and cartridge buttresses releasably secured thereto in accordance with an embodiment of the present disclosure;

[0022] FIG. 5 is a perspective view, with parts separated, of an anvil buttress retention system including the anvil buttress of FIG. 4 and a retention member;

[0023] FIGS. 6A and 6B are end views of the anvil buttress retention system of FIG. 5 in pre-tightened and tightened configurations, respectively;

[0024] FIG. 7 is a perspective view of the jaw assembly of FIG. 1, including anvil and cartridge buttresses releasably secured thereto in accordance with another embodiment of the present disclosure;

[0025] FIG. 8 is an end view of an anvil buttress retention system including the anvil buttress of FIG. 7 and a retention member;

[0026] FIG. 9 is a perspective view of the jaw assembly of FIG. 1, including a surgical buttress assembly releasably secured thereto in accordance with an embodiment of the present disclosure;

[0027] FIG. 10 is a perspective view of the surgical buttress assembly of FIG. 9;

[0028] FIG. 11 is a side view of the surgical buttress assembly of FIGS. 9 and 10, including an anvil buttress retention system;

[0029] FIG. 12 is a side view of a jaw assembly including a surgical buttress assembly releasably secured thereto in accordance with another embodiment of the present disclosure;

[0030] FIG. 13 is a cross-sectional view of a distal portion of an anvil assembly of the jaw assembly of FIG. 12;

[0031] FIG. 14 is a side view of the surgical buttress assembly of FIG. 12;

[0032] FIG. 15 is a top view of the surgical buttress assembly of FIGS. 12 and 14;

[0033] FIG. 16 is a perspective view of a jaw assembly including a surgical buttress assembly in accordance with yet another embodiment of the present disclosure; and

[0034] FIG. 17 is a perspective view of the surgical buttress assembly of FIG. 16.

DETAILED DESCRIPTION OF THE EMBODIMENTS

[0035] Various exemplary embodiments of the present disclosure are discussed herein below in terms of surgical buttresses for use with surgical stapling apparatus. The surgical buttresses

described herein may be used in sealing a wound by approximating the edges of wound tissue between a staple cartridge assembly and an anvil assembly of a surgical stapling apparatus which includes at least one surgical buttress. The surgical buttress is releasably attached to the surgical stapling apparatus such that staples fired from the surgical stapling apparatus attach the surgical buttress to tissue. Thus, the present disclosure describes embodiments of surgical buttresses for reinforcing and sealing staple lines applied to tissue by surgical stapling apparatus.

[0036] Embodiments of the presently disclosed surgical buttress will now be described in detail with reference to the drawing figures wherein like reference numerals identify similar or identical elements. Throughout this description, the term “proximal” refers to a portion of a structure, or component thereof, that is closer to a user, and the term “distal” refers to a portion of the structure, or component thereof, that is farther from the user. Directional reference terms, such as “top,” “bottom,” “back,” “side,” and the like, are intended to ease description of the embodiments and are not intended to have any limiting effect on the ultimate orientations of a structure or any parts thereof.

[0037] Referring now to FIG. 1, an exemplary surgical stapling apparatus or surgical stapler 1 is shown for use in stapling tissue and applying one or more buttress materials or surgical buttresses to the tissue. The surgical stapling apparatus 1 generally includes a handle assembly 10, an elongate tubular body portion 20 extending distally from the handle assembly 10, and an end effector or jaw assembly 30 extending distally from the elongate tubular body portion 20. The jaw assembly 30 includes an anvil assembly 40 and a staple cartridge assembly 50. The jaw assembly 30 may be permanently affixed to the elongate tubular body portion 20 or may be detachable with respect to the elongate tubular body portion 20 and thus, replaceable with a new jaw assembly 30. The anvil assembly 40 and/or the staple cartridge assembly 50 is pivotable with respect to the elongate tubular body portion 20 such that the anvil and staple cartridge assemblies 40, 50 are movable between an open position in which the anvil and staple cartridge assemblies 40, 50 are spaced apart with respect to each other and a closed position in which the anvil and staple cartridge assemblies 40, 50 are substantially adjacent each other.

[0038] The handle assembly 10 includes a stationary handle member 12a, a movable handle member 12b, and a barrel portion 14. An articulation lever 16 is mounted on the forward end of the barrel portion 14 to facilitate articulation of the jaw assembly 30. A rotatable member 18 is also mounted on the forward end of the barrel portion 14, adjacent the articulation lever 16.

Rotation of the rotatable member 18 relative to the barrel portion 14 rotates the elongate tubular body portion 20 and the jaw assembly 30 relative to the handle assembly 10 so as to properly orient the anvil and staple cartridge assemblies 40, 50 relative to tissue to be stapled. A pair of knobs 19 is movably positionable along the barrel portion 14. The pair of knobs 19 is advanced distally to approximate or close the anvil and staple cartridge assemblies 40, 50, relative to each other, and retracted proximally to unapproximate or open the anvil and staple cartridge assemblies 40, 50, with respect to each other. Actuation of the movable handle member 12b applies lines of staples 58 (FIG. 2) to tissue captured between the anvil and staple cartridge assemblies 40, 50.

[0039] As seen in FIG. 2, the anvil assembly 40 includes an anvil plate 42 having a central longitudinal slot 43 formed therein, and a cover plate 44 secured over the anvil plate 42 such that the cover plate 44 defines a top or outwardly facing surface 46 of the anvil assembly 40. As seen in FIG. 3, the anvil plate 42 includes a plurality of staple forming pockets/cavities 45 defined in an inward or tissue facing surface 48 thereof.

[0040] With continued reference to FIG. 2, the cartridge assembly 50 includes a carrier 52 defining an elongated support channel 52a configured and dimensioned to selectively receive a staple cartridge 54 therein. The staple cartridge 54 is removable and replaceable in the carrier 52 of the staple cartridge assembly 50. The staple cartridge 54 includes an inward or tissue facing surface 56 defining staple pockets or retention slots 55 formed therein for receiving a plurality of fasteners or staples 58 and staple pushers 60. A central longitudinal slot 57 is formed in and extends along a substantial length of the staple cartridge 54 to facilitate passage of a knife blade 62 of a drive bar 64 therethrough. During operation of the surgical stapler 1, an actuation sled 66 translates through the staple cartridge 54 to advance cam wedges 68 of the actuation sled 66 into sequential contact with the staple pushers 60, to cause the staple pushers 60 to translate vertically within the staple pockets 55 and urge the staples 58 from the staple pockets 55 and into the staple forming cavities 45 of the anvil plate 42 of the anvil assembly 40.

[0041] For a detailed description of the structure and function of exemplary surgical stapling apparatus, reference may be made to U.S. Patent Nos. 6,330,965, 6,241,139, and 7,819,896, the entire contents of each of which are incorporated herein by reference. It should be appreciated that principles of the present disclosure are equally applicable to surgical stapling apparatus having other configurations such as, for example, the types described in U.S. Patent Nos.

7,128,253, 7,334,717, and 5,964,394, the entire contents of each of which are incorporated herein by reference. Accordingly, it should be understood that a variety of surgical stapling apparatus may be utilized with surgical buttresses of the present disclosure. For example, laparoscopic or open staplers, such as, for example, GIATM, Endo GIATM, TATM, and Endo TATM staplers and/or linear and radial reloads with, for example, Tri-StapleTM technology, available through Medtronic (North Haven, CT) may be utilized with the surgical buttresses of the present disclosure.

[0042] With reference now to FIG. 4, surgical buttresses 110, 120 (also referred to herein as anvil buttress 110 and cartridge buttress 120) are releasably attached to the respective anvil and staple cartridge assemblies 40, 50 of the jaw assembly 30 of the surgical stapler 1 (FIG. 1). The surgical buttresses 110, 120 are fabricated from biocompatible materials which are bioabsorbable or non-absorbable, natural or synthetic materials. It should be understood that any combination of natural, synthetic, bioabsorbable, and/or non-bioabsorbable materials may be used to form the surgical buttresses 110, 120. The surgical buttresses 110, 120 may be formed from the same material or different materials.

[0043] The surgical buttresses 110, 120 may be porous, non-porous, or combinations thereof. Suitable porous structures include, for example, fibrous structures (e.g., knitted structures, woven structures, and non-woven structures) and/or foams (e.g., open or closed cell foams). Suitable non-porous structures include, for example, films. The surgical buttresses 110, 120 described herein may be a single porous or non-porous layer, or include a plurality of layers including any combination of porous and non-porous layers. For example, a surgical buttress may include multiple porous and non-porous layers that are stacked in an alternating manner. In another example, a surgical buttress may be formed in a “sandwich-like” manner wherein the outer layers of the surgical buttress are porous and the inner layer(s) are non-porous, or vice versa. The surgical buttresses 110, 120 may have the same or a different structure of layer(s).

[0044] Porous layer(s) in a surgical buttress may enhance the ability of the surgical buttress to absorb fluid, reduce bleeding, and seal the wound. Also, the porous layer(s) may allow for tissue ingrowth to fix the surgical buttress in place. Non-porous layer(s) in a surgical buttress may enhance the ability of the surgical buttress to resist tears and perforations during the manufacturing, shipping, handling, and stapling processes. Also, non-porous layer(s) may

retard or prevent tissue ingrowth from surrounding tissues thereby acting as an adhesion barrier and preventing the formation of unwanted scar tissue.

[0045] It should be understood that while the surgical stapler 1 is shown including both the anvil and cartridge buttresses 110, 120, the surgical stapler 1 may include only the anvil buttress 110 or the cartridge buttress 120 depending on, for example, the surgical application and/or desired placement of the buttress material relative to tissue as should be understood by those skilled in the art. The anvil buttress 110 and/or the cartridge buttress 120 may be pre-loaded (e.g., by the manufacturer) onto the anvil assembly 40 and/or staple cartridge assembly 50 of the jaw assembly 30. Additional or replacement anvil buttresses 110 and/or cartridge buttresses 120 may be secured to the respective anvil and/or staple cartridge assemblies 40, 50 as needed or desired.

[0046] With continued reference to FIG. 4, the cartridge buttress 120 includes a body portion 120a configured to overlie at least a portion of the tissue facing surface 56 (FIG. 2) of the staple cartridge assembly 50, a neck portion 120b extending distally from the body portion 120a, and a head portion 120c extending distally from the neck portion 120b. For a detailed description of the structure and function of exemplary surgical buttress configurations suitable for use with the staple cartridge assembly 50, reference may be made to commonly owned U.S. Patent Appl. Pub. Nos. 2014/0138423 (“the ‘423 application”) and 2013/0105548 (“the ‘548 application”), the entire contents of each of which are incorporated herein by reference.

[0047] The cartridge buttress 120 is releasably attached to the staple cartridge assembly 50 via any suitable attachment feature within the purview of those skilled in the art, such as, chemical attachment features (e.g., adhesives), mechanical attachment features (e.g., mounting structures, such as pins or straps), and/or attachment methods (e.g., welding). For a detailed description of exemplary attachment features suitable for use with the cartridge buttress 120, reference may be made to the ‘423 and ‘548 applications, the entire contents of each of which were previously incorporated herein by reference.

[0048] As shown in FIGS. 4 and 5, the anvil buttress 110 is in the form of a sleeve defining a cavity 111 therein that is configured to receive the anvil assembly 40 such that the anvil buttress 110 is disposed around the anvil assembly 40. Proximal and distal ends 110a, 110b of the anvil buttress 110 may be open to the cavity 111. In embodiments, the proximal end 110a of the anvil

buttress 110 is open and configured to receive the anvil assembly 40, and the distal end 110b is closed and configured to contact a distal end of the anvil assembly 40 to prevent further proximal movement of the anvil buttress 110 relative to the anvil assembly 40.

[0049] The anvil buttress 110 includes a first layer 112 secured to a second layer 114 along respective lateral edges thereof to define the cavity 111 therebetween. In embodiments, the first and second layers 112, 114 are integrally formed from a single piece of buttress material that is shaped (e.g., rolled) to define the cavity 111 therein. In embodiments, perforations 115 are formed at the junction of the first and second layers 112, 114 to allow for the first layer 112 to separate from the second layer 114 after a stapling procedure is performed, as described in further detail below.

[0050] The anvil buttress 110 is slid proximally over the anvil assembly 40 such that the first layer 112 is positioned adjacent the tissue facing surface 48 (FIG. 3) of the anvil assembly 40, and the second layer 114 is positioned adjacent the top surface 46 of the anvil assembly 40. In some embodiments, the anvil buttress 110 has a pre-formed shape in which a lateral dimension of the cavity 111 is greater than a vertical dimension of the cavity 111 such that the anvil buttress 110 may be properly oriented on the anvil assembly 40.

[0051] With continued reference to FIGS. 4 and 5, the anvil buttress 110 is secured to the anvil assembly 40 by at least one retention member 130. The retention member 130 is fabricated from biocompatible materials which are any combination of natural, synthetic, bioabsorbable, and/or non-bioabsorbable materials. The retention member 130 includes an elongated body 132 having a free end 132a and a looped end 132b, and may be in the form of a suture, thread, filament, etc. The retention member 130 includes a plurality of barbs 134 extending from the elongated body 132 that are configured to grip the portion of the anvil buttress 110 over which it extends, as well as the looped end 132b when the free end 132a is passed therethrough to allow for quick assembly and securement of the retention member 130 and thus, the anvil buttress 110 to the anvil assembly 40. In embodiments, the plurality of barbs 134 are compound barbs. For a detailed description of the structure of exemplary compound barb configurations, reference may be made to U.S. Patent No. 8,273,105, the entire contents of which are incorporated herein by reference.

[0052] It should be understood that while two retention members 130 are shown in FIG. 4, one on a proximal portion of the anvil buttress 110 and one on a distal portion of the anvil buttress 110, the number of retention members 130, and the placement of the retention members 130 relative to the anvil buttress 110, may vary. In embodiments, the retention members 130 are disposed on the anvil buttress 100 and extend across the central longitudinal slot 43 (FIG. 2) of the anvil assembly 40 such that actuation of the knife blade 62 (FIG. 2) results in severing of the retention members 130.

[0053] As shown in FIGS. 6A and 6B, the anvil buttress 110 and at least one retention member 130 are pre-assembled as an anvil buttress retention system 140 prior to positioning the anvil buttress 110 over the anvil assembly 40. As shown in FIG. 6A, the retention member 130 is pre-looped around the anvil buttress 110 with the free end 132a extending through the looped end 132b. The barbs 134 of the retention member 130 may aid in retaining the retention member 130 at a desired location along the length of the anvil buttress 110. In embodiments, the retention member 130 is attached to the anvil buttress 110 at a joint (e.g., on a tissue facing side of the anvil buttress 110) by, for example, using adhesives or welding the retention member 130 to the anvil buttress 110 to maintain the desired axial position of the retention member 130 along the length of the anvil buttress 110.

[0054] The anvil buttress retention system 140, in the untightened configuration shown in FIG. 6A, is slid over the anvil assembly 40 (FIG. 4), as described above. As shown in FIG. 6B, after the anvil buttress retention system 140 is placed on the anvil assembly 40 (FIG. 4), the free end 132a of the retention member 130 is pulled to tighten the retention member 130 around the anvil buttress 110 thereby securing the anvil buttress 110 to the anvil assembly 40.

[0055] In operation, with the anvil buttress retention system 140 loaded onto the anvil assembly 40, as described above, and the cartridge buttress 120 loaded onto the staple cartridge assembly 50, the surgical stapler 1 is used in accordance with methods known by those skilled in the art. Once the anvil and staple cartridge assemblies 40, 50 are clamped onto tissue (e.g., moved from the open position to the closed position), the surgical stapler 1 is fired. In firing the surgical stapler 1, the drive bar 64 is advanced distally through the jaw assembly 30 urging the staple pushers 60 upwardly which, in turn, drive the staples 58 out of the staple pockets 55 and through the anvil and cartridge buttresses 110, 120 as well as the captured tissue, thereby stapling the anvil and cartridge buttresses 110, 120 to the tissue.

[0056] During firing, the knife blade 62 of the drive bar 64 travels distally while substantially simultaneously cutting and dividing the tissue and anvil and cartridge buttresses 110, 120 disposed between the rows of now formed staples 58, as well as a portion of the retention member(s) 130 extending across the central longitudinal slot 43 of the anvil assembly 40 to free the anvil buttress 110 from the anvil assembly 40. When firing is complete, and the anvil and staple cartridge assemblies 40, 50 are unclamped, the anvil and cartridge buttresses 110, 120, which are now stapled to the tissue, pull away from the anvil and staple cartridge assemblies 40, 50 as the anvil and staple cartridge assemblies 40, 50 are withdrawn from within cavities 111 of the anvil and cartridge buttresses 110, 120. In embodiments, the first layer 112 of the anvil buttress 110 separates from the second layer 114 at the perforations 115 when the jaw assembly 30 is opened after performing the stapling procedure. It is understood that since **the** anvil buttress 110, the cartridge buttress 120 and the retention member(s) 130 are bioabsorbable they would be absorbed by the body over time.

[0057] Turning now to FIGS. 7 and 8, a jaw assembly 30 including a cartridge buttress 120 and an anvil buttress 150 in accordance with another embodiment of the present disclosure is shown. The anvil buttress 150 includes a body or central portion 152 and a pair of wings or side portions 154 extending vertically from side edges of the central portion 152 to define a substantially u-shaped channel 153 therebetween. The central portion 152 of the anvil buttress 150 is positioned adjacent the inward facing surface 48 (FIG. 2) of the anvil assembly 40 such that the anvil assembly 40 is positioned within the channel 153 of the anvil buttress 150. The pair of wings 154 are positioned adjacent sides of the anvil assembly 40 and extend upwardly past the cover plate 44 of the anvil assembly 40. The anvil buttress 150 is secured to the anvil assembly 40 by at least one retention member 130. As shown in FIG. 7, two retention members 130 secure the anvil buttress 150 to the anvil assembly 40, one on a proximal portion of the anvil buttress 150 and one on a distal portion of the anvil buttress 150.

[0058] The anvil buttress 150 and the at least one retention member 130 are pre-assembled as an anvil buttress retention system 160 prior to positioning the anvil buttress 150 on the anvil assembly 40. As shown in FIG. 8, the retention member 130 is pre-looped through side edges of the central portion 152 of the anvil buttress 150 and extends upwardly adjacent inner sides of the pair of wings 154 with the free end 132a of the retention member 130 extending through the looped end 132b above the channel 153 of the anvil buttress 150. After the anvil buttress retention system 160 is placed on the anvil assembly 40 as shown, for example, in FIG. 7 (e.g.,

by sliding the anvil buttress retention system 160 proximally onto the anvil assembly 40), the free end 132a of the retention member 130 is pulled to tighten the retention member 130 thereby securing the anvil buttress 150 to the anvil assembly 40.

[0059] During firing of a surgical stapler 1 including the anvil buttress retention system 160, distal movement of the knife blade 62 cuts and divides the captured tissue, the anvil buttress 150, as well as a portion of the retention member(s) 130 extending across the central longitudinal slot 43 of the anvil assembly 40 to free the anvil buttress 150 from the anvil assembly 40. When firing is complete, the jaw assembly 30 is moved to the open position and the anvil buttress 150 is pulled away from the anvil assembly 40.

[0060] With reference now to FIGS 9-11, a surgical buttress assembly 200 in accordance with an embodiment of the present disclosure is shown releasably disposed on a jaw assembly 30. The surgical buttress assembly 200 includes an anvil buttress 210 and a cartridge buttress 220 interconnected by a connecting member 230. It should be understood while both the anvil and cartridge buttresses 210, 220 are shown including a body portion 210a, 220a, a neck portion 210b, 220b, and a head portion 210c, 220c, the anvil and/or cartridge buttresses 210, 220 may have different configurations, as described above.

[0061] The connecting member 230 is attached to proximal ends 210d, 220d of the anvil and cartridge buttresses 210, 220. The connecting member 230 may be formed from the same material(s) as the anvil buttress 210 and/or the cartridge buttress 220, or may be formed from different material(s). The connecting member 230 may be, for example, a film or a web of fibrous material. In some embodiments, the connecting member 230 is formed from a rapidly degrading or rapidly absorbing polymer that degrades and/or is absorbed quickly upon implantation, thereby freeing the anvil and cartridge buttresses 210, 220 from each other.

[0062] The anvil buttress 210 is part of an anvil buttress retention system 240 which includes an adhesive layer 212 disposed on an anvil facing surface 211a of the anvil buttress 210 and a porous layer 214 releasably disposed on a tissue facing surface 211b of the anvil buttress 210. The porous layer 214 may be, for example, a sponge or a foam. In embodiments, the porous layer 214 is releasably attached to the anvil buttress 210 at one or more attachment points (e.g., adhesive attachment points). A release liner 216 may be disposed over the adhesive layer 212 prior to placement of the anvil buttress retention system 240 onto the anvil assembly 40.

[0063] In a method of loading the surgical buttress assembly 200 onto the jaw assembly 30, the cartridge buttress 220 is releasably attached to the staple cartridge assembly 50 via any suitable attachment feature, as described above. The release liner 216 is removed from the anvil buttress retention system 240 and the adhesive layer 212 is aligned and positioned against the tissue facing surface 48 (FIG. 2) of the anvil assembly 40. A clamping cycle is performed in which the anvil and staple cartridge assemblies 40, 50 are moved from the open position to the closed position and back to the open position. Upon movement to the closed position, the anvil and cartridge buttresses 210, 220 are compressed against opposed sides of the porous layer 214 to secure the adhesive layer 212 and thus, the anvil buttress 210 to the anvil assembly 40. The porous layer 214 may also cushion the anvil and cartridge buttresses 210, 220 during the clamping cycle to minimize any damage which may occur to the anvil and/or cartridge buttresses 210, 220. After re-opening the jaw assembly 30, the porous layer 214 is removed from the anvil buttress 210, rendering the jaw assembly 30 loaded and ready for use as shown, for example, in FIG. 9.

[0064] With reference now to FIG. 12, a surgical buttress assembly 300 in accordance with another embodiment of the present disclosure is shown releasably disposed on a jaw assembly 30'. The jaw assembly 30' is substantially similar to the jaw assembly 30 and will be described in detail herein to the extent necessary to describe the differences in construction and operation thereof. The jaw assembly 30' includes an anvil assembly 40' and a staple cartridge assembly 50. As shown in FIG. 13, the anvil assembly 40' includes an anvil plate 42' and a cover plate 44' which, together, define a proximally tapering passage 41' including a proximal junction 43' extending therein in which the anvil plate 42' and the cover plate 44' converge and/or define a minimal gap distance therebetween to releasably retain a tab 312 extending from an anvil buttress 310 in the anvil assembly 40', as described in further detail below.

[0065] As shown in FIGS. 14 and 15, the surgical buttress assembly 300 has a generally z-shaped configuration including an anvil buttress 310 and a tab 312, which together form the anvil buttress retention system 340, and a cartridge buttress 320 connected to the anvil buttress 310 by a connecting member 330. The tab 312 includes a proximal portion 312a, a central portion 312b including an aperture 313 formed therein, and a distal portion 312c. The connecting member 330 includes a notch 332 defined in a proximal end thereof that is axially aligned with the central longitudinal slots 43, 57 (FIG. 2) of the anvil and staple cartridge assemblies 40', 50. The notch 332 permits longitudinal reception of the knife blade 62 (FIG. 2)

of the staple cartridge assembly 50 therethrough to reduce any bunching of the surgical buttress assembly 300 as the knife blade 62 is distally advanced during firing.

[0066] With reference again to FIGS. 12 and 13, the tab 312 extends through the passage 41' of the anvil assembly 40' and is secured therein by aligning the aperture 313 of the central portion 312b of the tab 312 with the proximal junction 43' of the anvil plate 42' and the cover plate 44' such that the proximal portion 312a of the tab 312 is positioned above and adjacent to the central longitudinal slot 43 (FIG. 2) of the anvil plate 42' and the distal portion 312c of the tab 312 is loosely retained within the passage 41'. The tab 312 may be secured to the anvil assembly 40' by threading the tab 312 through the passage 41' of the anvil assembly 40' or positioning the tab 312 around the anvil plate 42' prior to securing the cover plate 44' thereto. During firing of the surgical stapler 1, distal movement of the knife blade 62 (FIG. 2) cuts the proximal portion 312a of the tab 312 thereby freeing the anvil buttress 310 from the anvil assembly 40'.

[0067] The cartridge buttress 320 is releasably attached to the staple cartridge assembly 50 via any suitable attachment feature, as described above. In embodiments, the cartridge buttress 320 is releasably secured to the staple cartridge assembly 50 via sutures 350 that extend across the cartridge buttress 320 and are secured to side surfaces thereof. The sutures 350 also extend across the central longitudinal slot 57 (FIG. 2) of the staple cartridge assembly 50 such distal movement of the knife blade 62 (FIG. 2) cuts a portion of the suture 350 to free the cartridge buttress 320 from the staple cartridge assembly 50.

[0068] With reference now to FIGS. 16 and 17, a surgical buttress assembly 400 in accordance with another embodiment of the present disclosure is shown loaded on a jaw assembly 30". The jaw assembly 30" is substantially similar to jaw assembly 30 except that the anvil assembly 40" defines one or more recesses or notches 41" formed in side surfaces thereof. The recesses 41" of the anvil assembly 40" are configured to selective couple an anvil buttress 410 to the anvil assembly 40", as described in further detail below.

[0069] The surgical buttress assembly 400 includes an anvil buttress 410 and a cartridge buttress 420 interconnected by a connecting member 430. The anvil and cartridge buttresses 410, 420 include a body portion 410a, 420a, a neck portion 410b, 420b, and a head portion 410c, 420c, however, as discussed above, other configurations are envisioned. The anvil

buttress 410 and a plurality of tabs 412 define an anvil buttress retention system 440 of the surgical buttress assembly 400. The plurality of tabs 412 extend from opposed side edges of the anvil buttress 410. Each tab 412 includes a body 412a and an enlarged head 412b. The body 412a of the tab 412 is configured and dimensioned to be received and retained within one of the recesses 41'' of the anvil assembly 40'' (e.g., snapped into the recess 41''), with the enlarged head 412b disposed above the anvil assembly 40'' to prevent movement of the anvil buttress 410 relative to the anvil assembly 40''. The cartridge buttress 420 is secured to the staple cartridge assembly 50 via any suitable mechanism, as described above.

[0070] After firing of a surgical stapler including the jaw assembly 30'' loaded with the surgical buttress assembly 400, re-opening the jaw assembly 30'' after firing the surgical stapler provides sufficient force to separate the stapled anvil and cartridge buttresses 410, 420 from the anvil and staple cartridge assemblies 40'', 50.

[0071] The surgical buttresses and anvil buttress retention systems described herein may also be configured for use with other surgical apparatus, such as electromechanical surgical devices as described, for example, in U.S. Patent Appl. Pub. Nos. 2015/0157320 and 2015/0157321, the entire contents of each of which are incorporated herein by reference.

[0072] Persons skilled in the art will understand that the systems, devices, and methods specifically described herein and illustrated in the accompanying figures are non-limiting exemplary embodiments, and that the description, disclosure, and figures should be construed merely exemplary of particular embodiments. It is to be understood, therefore, that the present disclosure is not limited to the precise embodiments described, and that various other changes and modifications may be effected by one skilled in the art without departing from the scope or spirit of the disclosure. Additionally, it is envisioned that the elements and features illustrated or described in connection with one exemplary embodiment may be combined with the elements and features of another exemplary embodiment without departing from the scope of the present disclosure, and that such modifications and variations are also intended to be included within the scope of the present disclosure. Accordingly, the subject matter of the present disclosure is not to be limited by what has been particularly shown and described.

CLAIMS:

1. A surgical stapling apparatus comprising:
an end effector having an anvil assembly and a staple cartridge assembly; and
an anvil buttress retention system releasably disposed on the anvil assembly, the anvil buttress retention system including an anvil buttress and a retention member including an elongated body looped around at least a portion of the anvil buttress with a free end of the elongated body extendable through a looped end of the elongated body in an untightened configuration such that the anvil buttress retention system is slidable relative to the anvil assembly, the free end of the retention member movable relative to and through the looped end to a tightened configuration to secure the anvil buttress retention system to the anvil assembly.
2. The surgical stapling apparatus according to claim 1, wherein the retention member includes a plurality of barbs extending from the elongated body.
3. The surgical stapling apparatus according to claim 1, wherein the anvil buttress is a sleeve defining a cavity therein, the cavity configured to receive the anvil assembly.
4. The surgical stapling apparatus according to claim 3, wherein the sleeve includes a first layer positionable adjacent a tissue facing surface of the anvil assembly and a second layer positionable adjacent an outwardly facing surface of the anvil assembly.
5. The surgical stapling apparatus according to claim 4, wherein the sleeve includes perforations extending along a length thereof and positioned between the first and second layers.
6. The surgical stapling apparatus according to claim 1, wherein the anvil buttress includes a central portion and a pair of wings extending from the central portion to define a u-shaped channel configured to receive the anvil assembly therein.
7. The surgical stapling apparatus according to claim 6, wherein the retention member is looped through side edges of the central portion and extends adjacent inner surfaces of the pair of wings such that the free and looped ends are disposed above the u-shaped channel of the anvil buttress.

8. The surgical stapling apparatus according to claim 1, further including a cartridge buttress releasably disposed on the staple cartridge assembly.
9. The surgical stapling apparatus according to claim 1, wherein the anvil assembly includes a central longitudinal slot, and the retention member extends across the central longitudinal slot of the anvil assembly.
10. The surgical stapling apparatus according to claim 1, wherein the retention member is a first retention member, and the anvil buttress retention system further includes a second retention member disposed in spaced relation relative to the first retention member along a length of the anvil buttress.
11. A method of loading the anvil buttress onto the end effector of the surgical stapling apparatus of claim 1, the method including:
 - sliding the anvil buttress of the anvil buttress retention system onto the anvil assembly of the end effector with the retention member in the untightened configuration; and
 - pulling the free end of the retention member relative to and through the looped end to the tightened configuration.
12. A surgical stapling apparatus comprising:
 - an end effector having an anvil assembly and a staple cartridge assembly; and
 - an anvil buttress retention system releasably disposed on the anvil assembly, the anvil buttress retention system including an anvil buttress, an adhesive layer disposed on an anvil facing surface of the anvil buttress, and a porous layer releasably disposed on a tissue facing surface of the anvil buttress.
13. The surgical stapling apparatus according to claim 12, further including a cartridge buttress interconnected with the anvil buttress by a connecting member.
14. A method of loading the anvil buttress onto the end effector of the surgical stapling apparatus of claim 12, the method including:
 - positioning the adhesive layer of the anvil buttress retention system against a tissue facing surface of the anvil assembly;
 - clamping the end effector such that the porous layer is compressed between the anvil and staple cartridge assemblies to secure the adhesive layer to the anvil assembly;

unclamping the end effector; and
removing the porous layer from the anvil buttress.

15. A surgical stapling apparatus comprising:

an end effector having an anvil assembly and a staple cartridge assembly, the anvil assembly including an anvil plate including a central longitudinal slot, a cover plate disposed over the anvil plate, and a proximally tapering passage disposed between the anvil plate and the cover plate; and

an anvil buttress retention system releasably disposed on the anvil assembly, the anvil buttress retention system including an anvil buttress and a tab extending proximally from a distal end of the anvil buttress, the tab positioned within the proximally tapering passage of the anvil assembly such that a proximal portion of the tab is disposed adjacent to the central longitudinal slot of the anvil plate.

16. The surgical stapling apparatus according to claim 15, wherein the tab includes an aperture configured to capture a portion of the anvil assembly therein.

17. The surgical stapling apparatus according to claim 15, further including a cartridge buttress connected to the anvil buttress by a connecting member to form a surgical buttress assembly having a substantially z-shaped configuration.

18. The surgical stapling apparatus according to claim 17, wherein the connecting member includes a notch formed therein, the notch aligned with the central longitudinal slot of the anvil plate.

19. The surgical stapling apparatus according to claim 17, wherein the cartridge buttress is releasably secured to the staple cartridge assembly by sutures.

20. A method of loading the anvil buttress onto the end effector of the surgical stapling apparatus of claim 15, the method including:

positioning the anvil buttress of the anvil buttress retention system against a tissue facing surface of the anvil assembly; and

passing the tab through the proximally tapering passage of the anvil assembly to secure the proximal portion of the tab adjacent the central longitudinal slot of the anvil plate.

Covidien LP

Patent Attorneys for the Applicant/Nominated Person

SPRUSON & FERGUSON

2019201033 14 Feb 2019

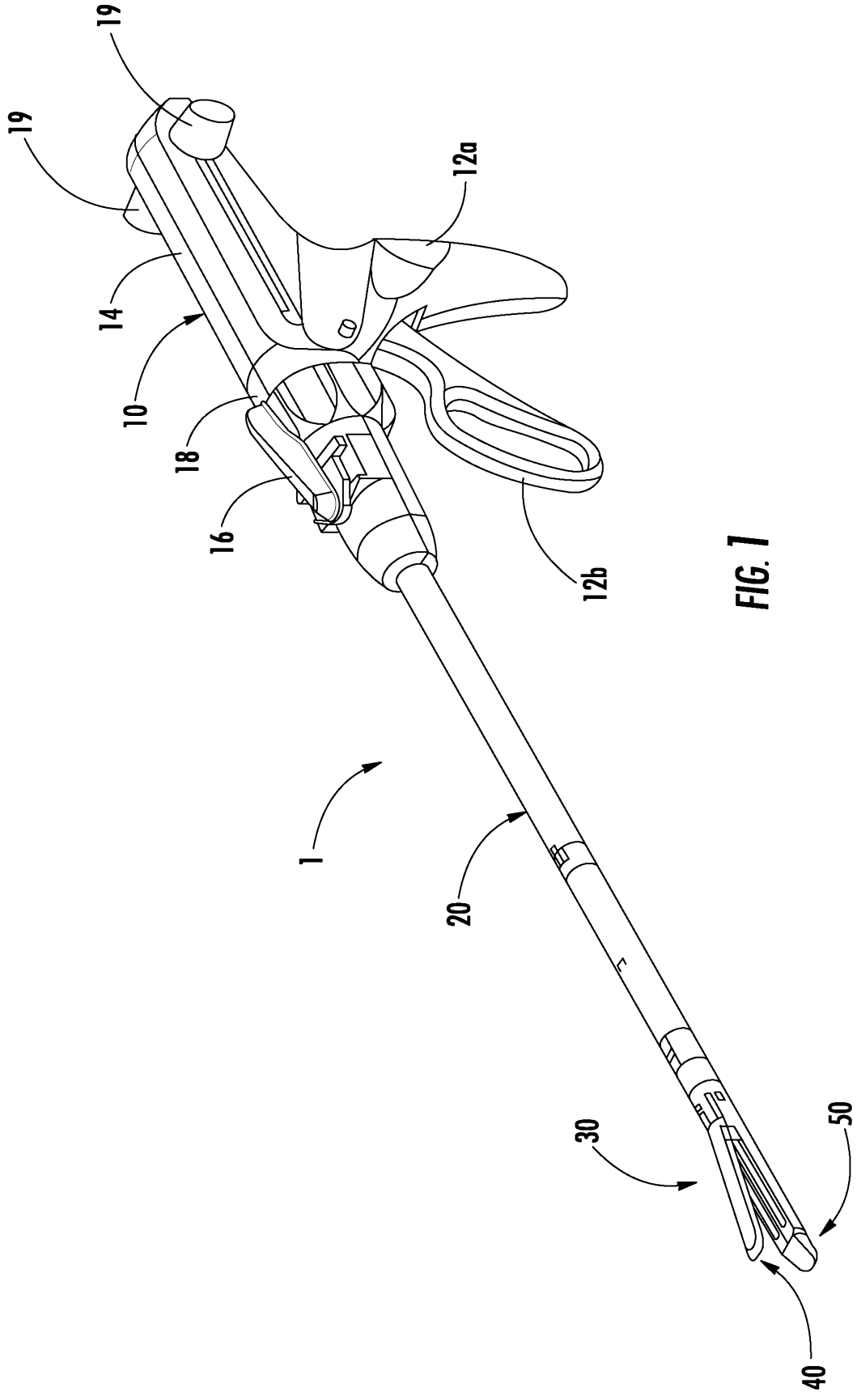

FIG. 1

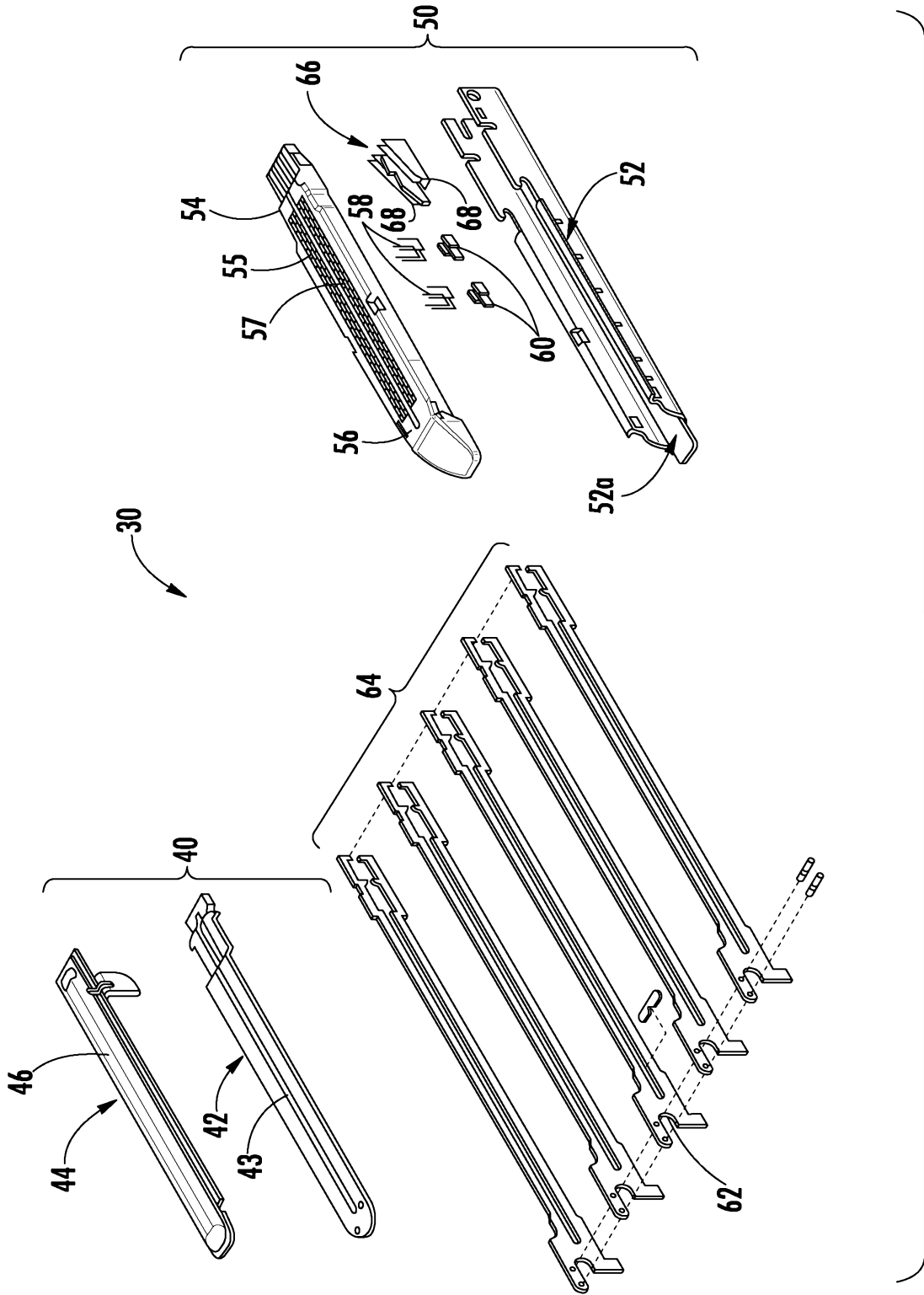
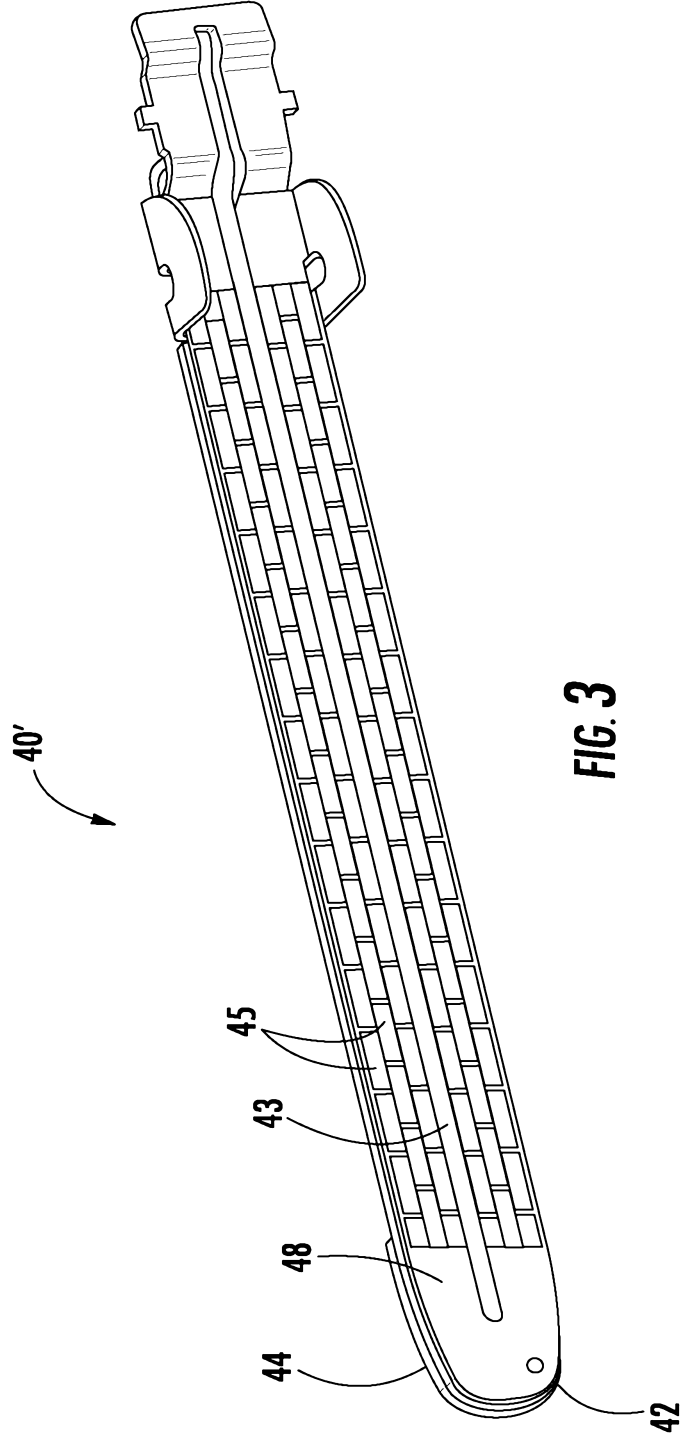
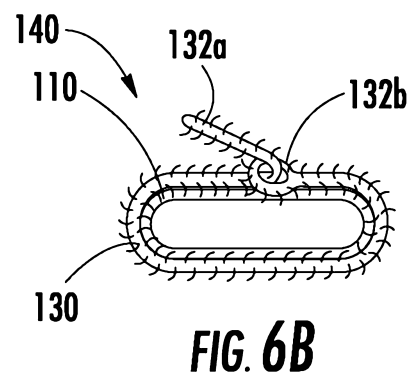
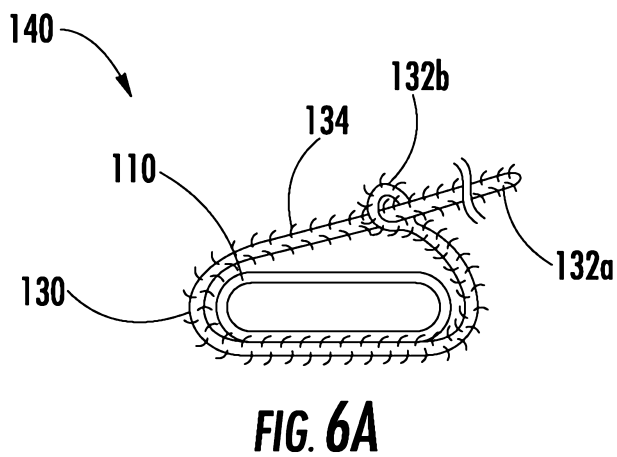
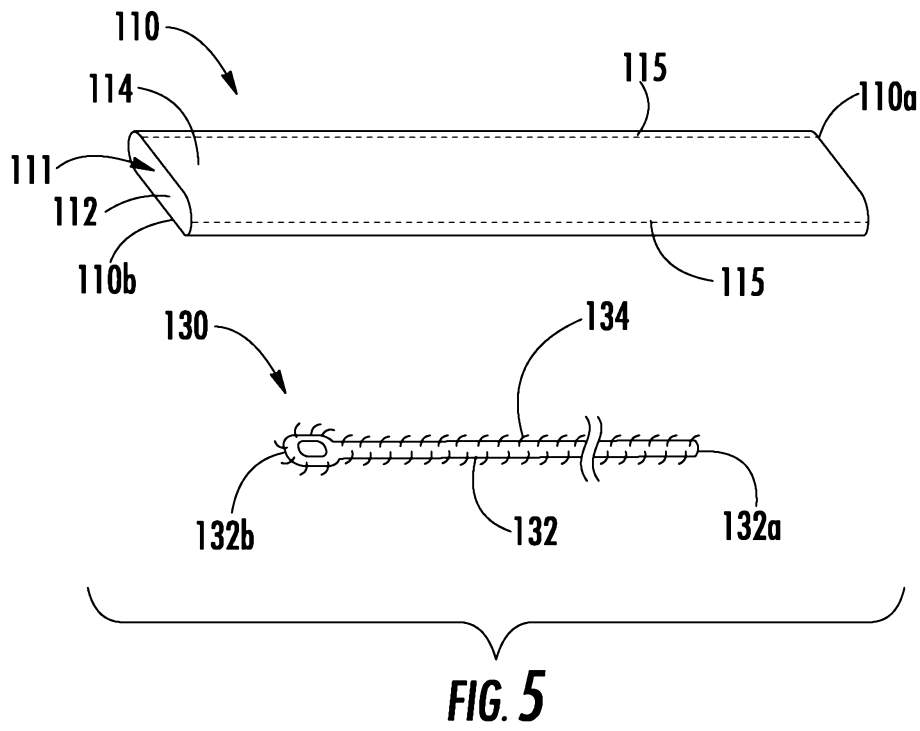
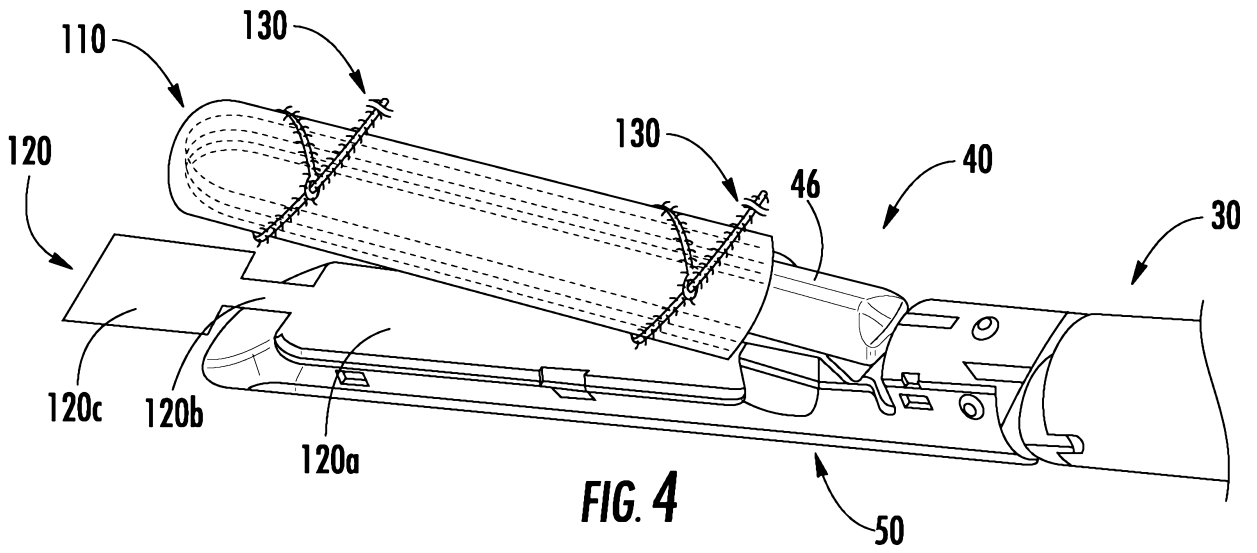
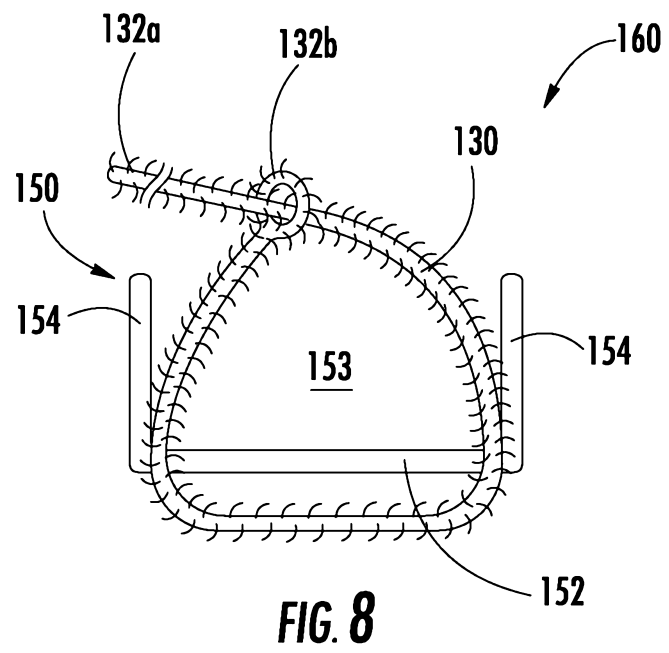
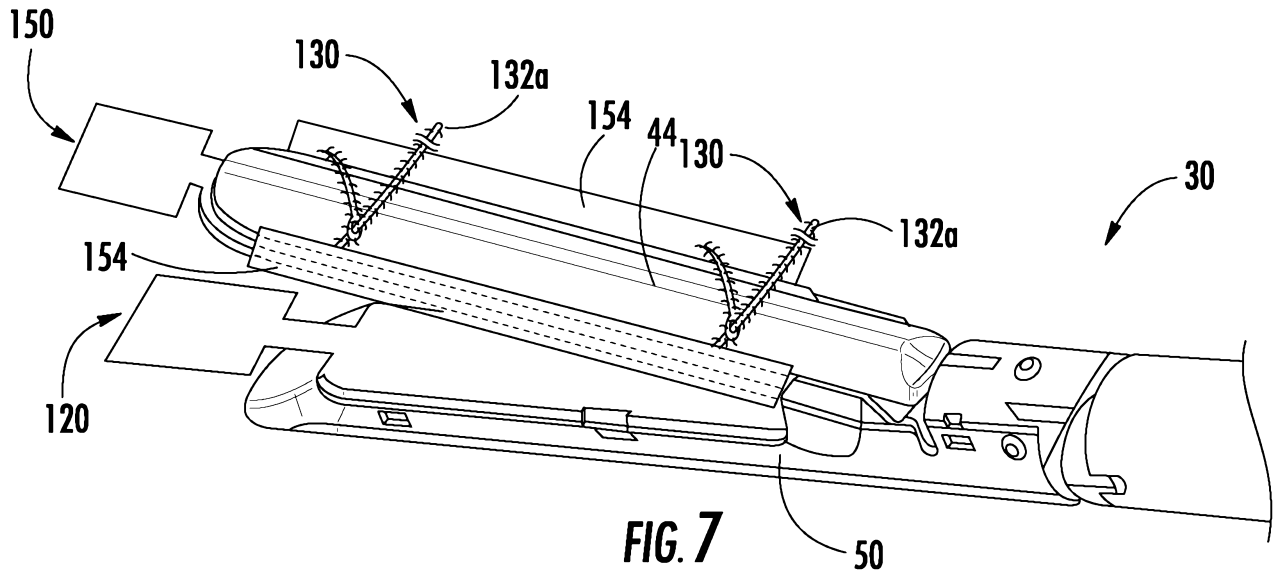

FIG. 2







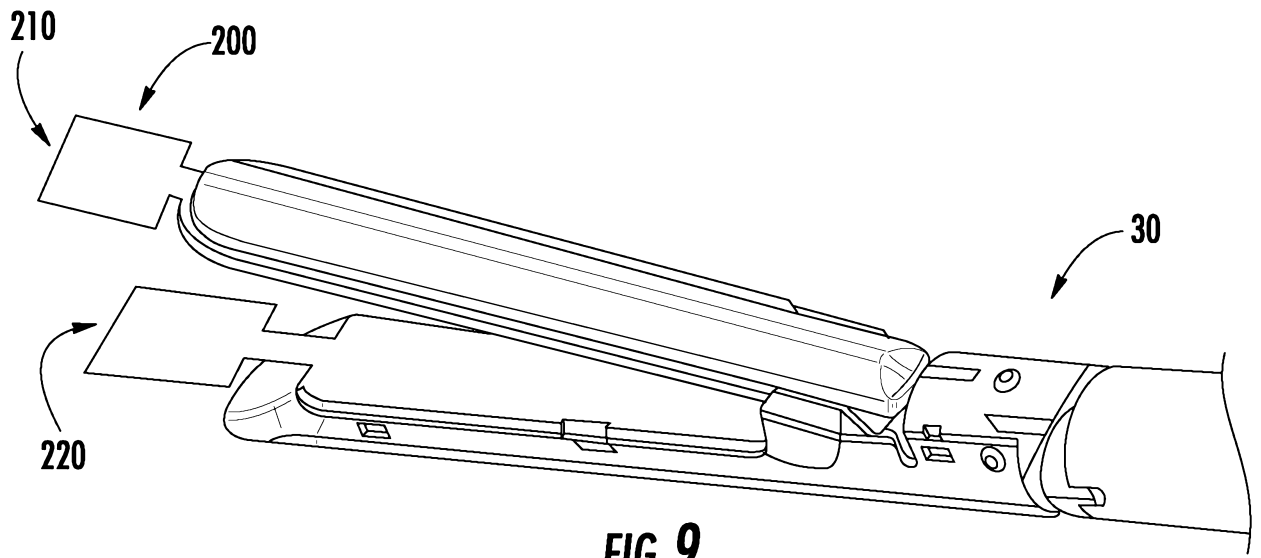

FIG. 9

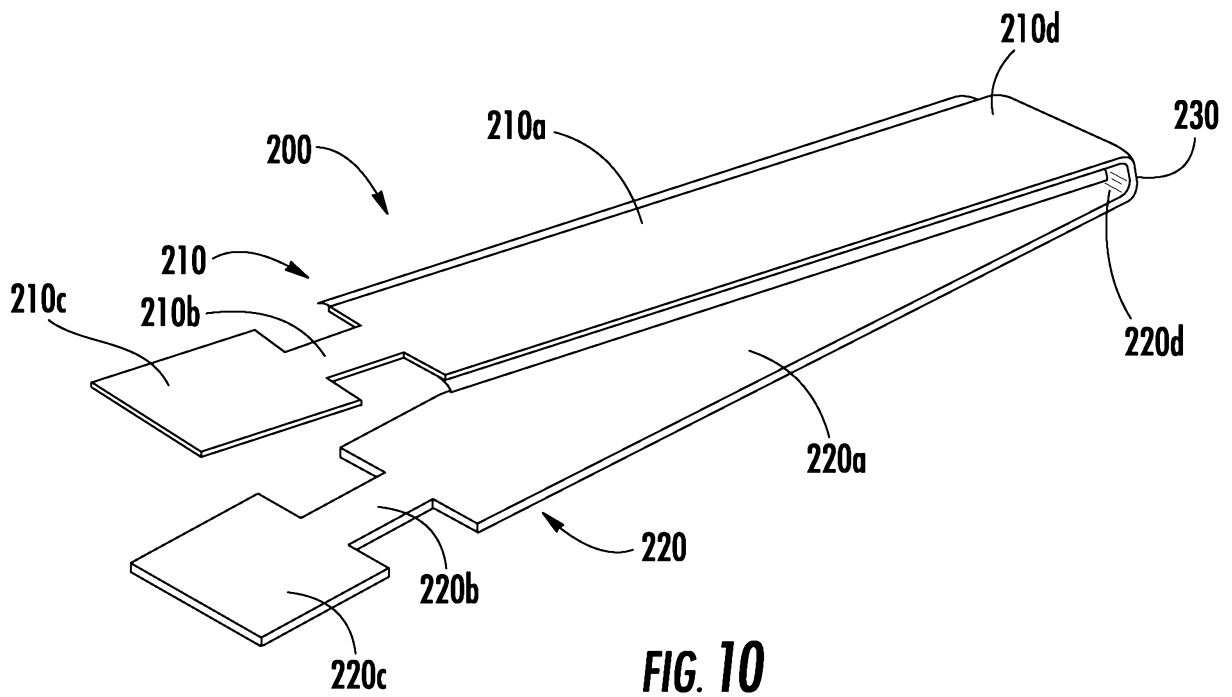

FIG. 10

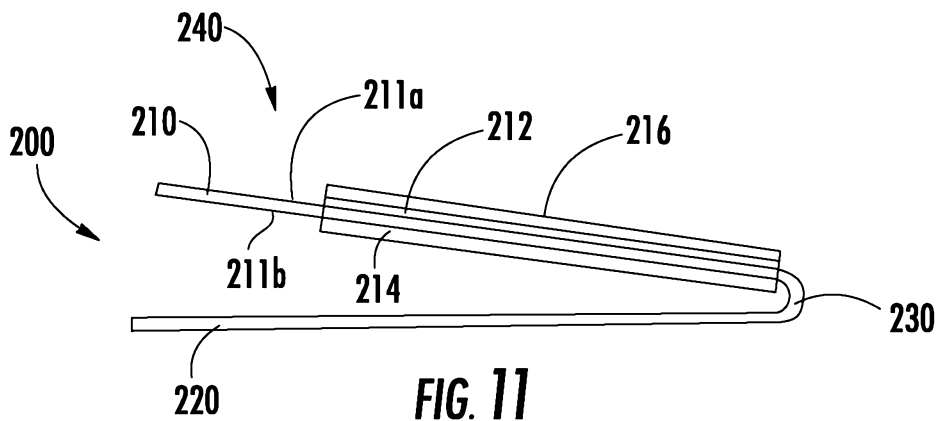

FIG. 11

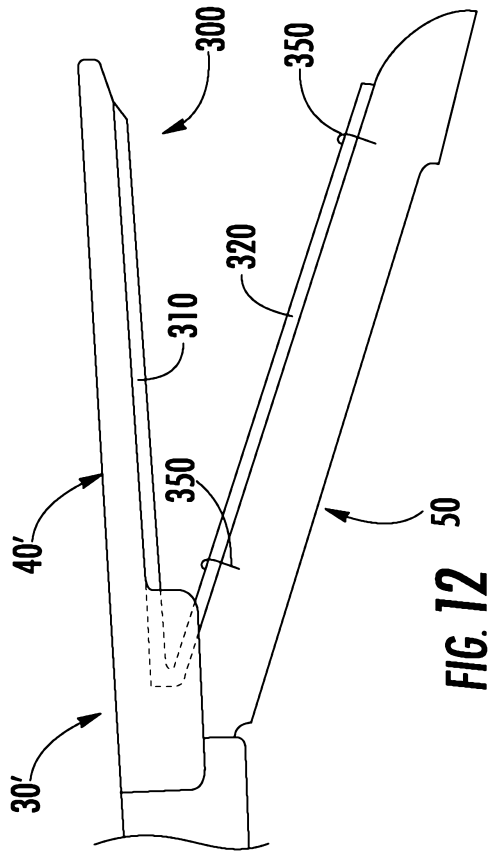

FIG. 12

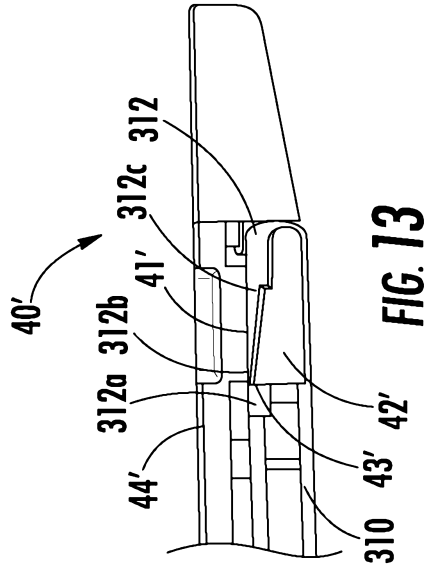

FIG. 13

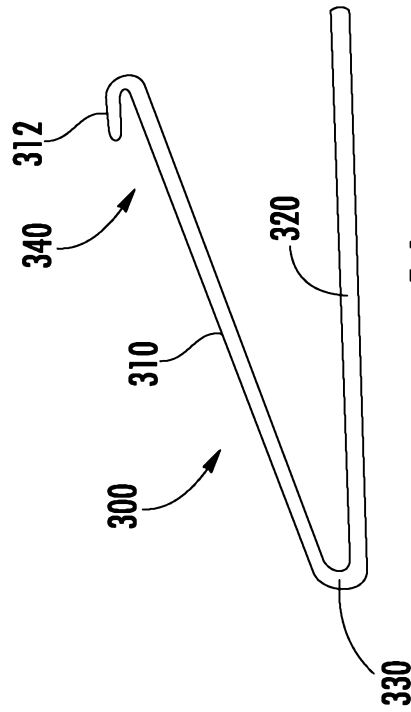

FIG. 14

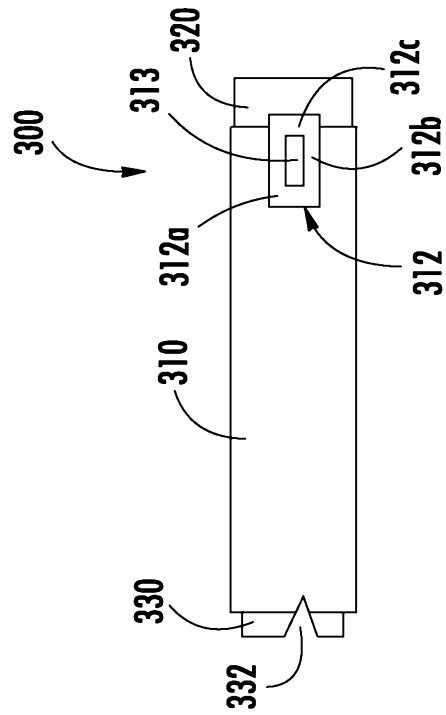

FIG. 15

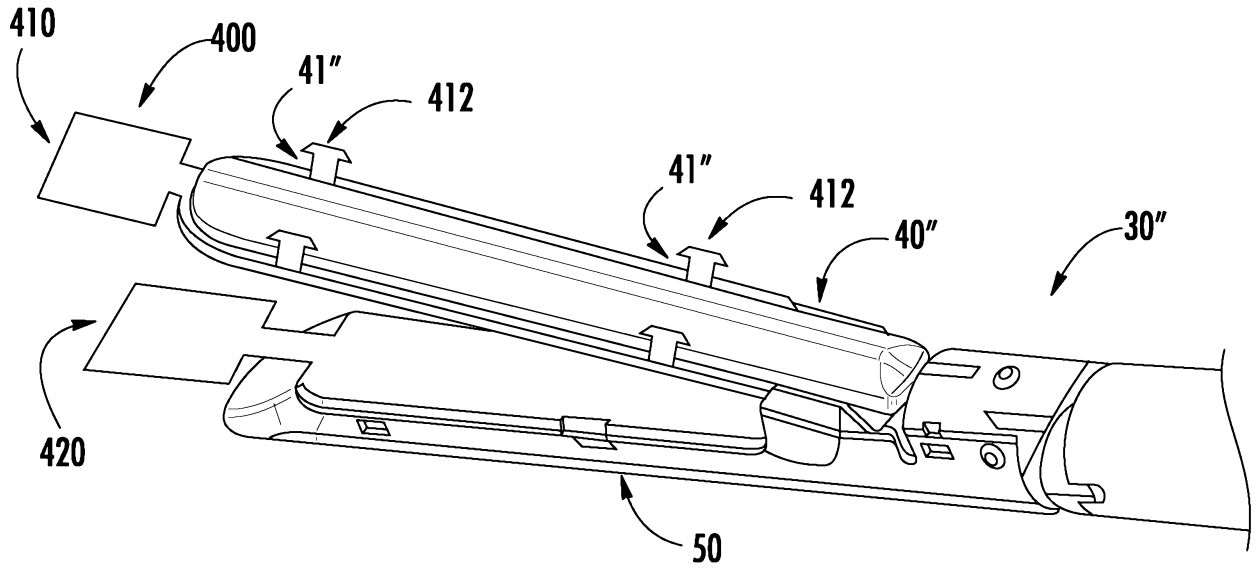

FIG. 16

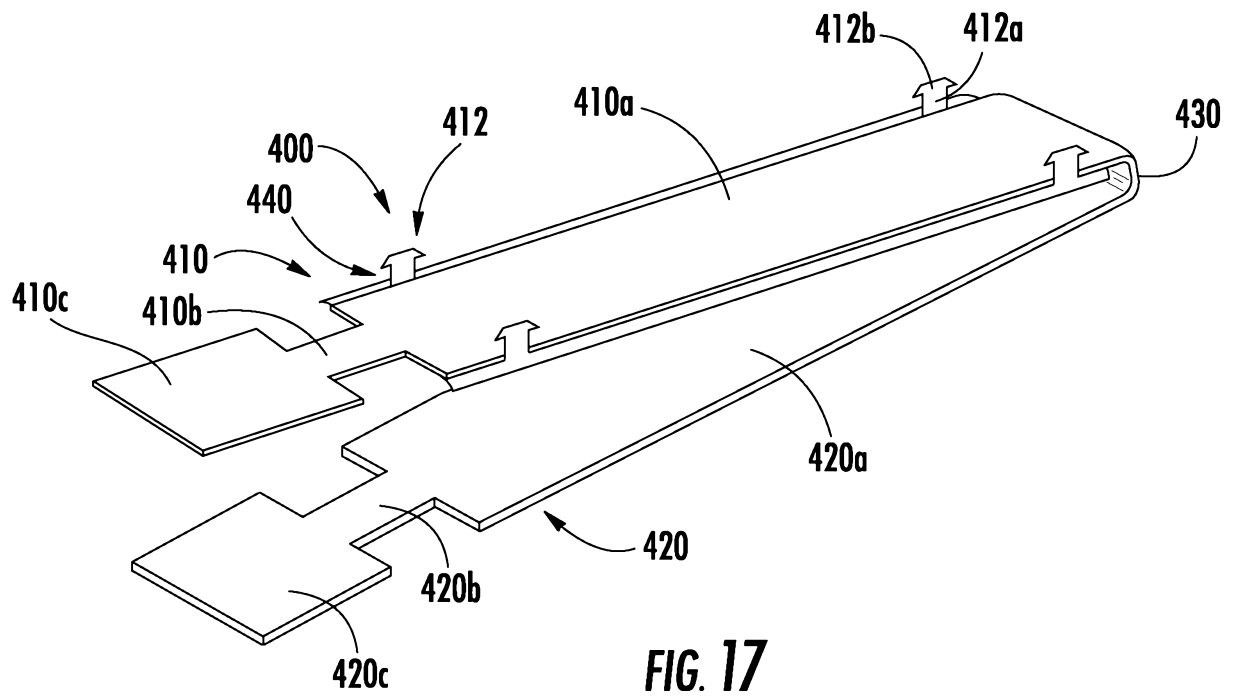

FIG. 17