

(19)



(11)

**EP 2 773 806 B1**

(12)

**EUROPEAN PATENT SPECIFICATION**

(45) Date of publication and mention of the grant of the patent:  
**03.02.2016 Bulletin 2016/05**

(51) Int Cl.:  
**D06F 58/04<sup>(2006.01)</sup> D06F 58/06<sup>(2006.01)</sup>**

(21) Application number: **12788478.1**

(86) International application number:  
**PCT/EP2012/071617**

(22) Date of filing: **31.10.2012**

(87) International publication number:  
**WO 2013/064568 (10.05.2013 Gazette 2013/19)**

(54) **A LAUNDRY DRYER COMPRISING A TRANSPORTATION SAFETY MEMBER**

**WÄSCHETROCKNER MIT TRANSPORTSICHERHEITSELEMENT**

**SÈCHE-LINGE COMPRENANT UN ÉLÉMENT DE SÉCURITÉ DE TRANSPORT**

(84) Designated Contracting States:  
**AL AT BE BG CH CY CZ DE DK EE ES FI FR GB GR HR HU IE IS IT LI LT LU LV MC MK MT NL NO PL PT RO RS SE SI SK SM TR**

(30) Priority: **04.11.2011 TR 201111061**

(43) Date of publication of application:  
**10.09.2014 Bulletin 2014/37**

(73) Proprietor: **Arçelik Anonim Sirketi**  
**34950 Istanbul (TR)**

(72) Inventors:  
• **KOSE, Egemen**  
**34950 Istanbul (TR)**  
• **ABDIK, Bora**  
**34950 Istanbul (TR)**  
• **DEMIRHAN, Dogan**  
**34950 Istanbul (TR)**  
• **GOKTAS, Murat**  
**34950 Istanbul (TR)**

(56) References cited:  
**EP-A1- 0 404 252 EP-A2- 0 136 491**  
**WO-A1-2005/066409 DE-A1-102005 009 230**

**EP 2 773 806 B1**

Note: Within nine months of the publication of the mention of the grant of the European patent in the European Patent Bulletin, any person may give notice to the European Patent Office of opposition to that patent, in accordance with the Implementing Regulations. Notice of opposition shall not be deemed to have been filed until the opposition fee has been paid. (Art. 99(1) European Patent Convention).

## Description

**[0001]** The present invention relates to a laundry dryer comprising a transportation safety member.

**[0002]** In laundry dryers, the laundry to be dried is loaded into a drum. The drying process is realized by this drum being driven and rotated by a motor. In the state of the art, a sliding or roller bearing system is used for drums to be borne from their front side. In laundry dryers wherein the roller system is preferred, at the moments of falling and impact that can occur during transportation, deformations occur depending on the impact on the drum areas wherein the rollers are contacted.

**[0003]** In the state of the art European Patent No. EP1702097, a washer/dryer is explained wherein a fixing mechanism is utilized to temporarily fasten the washing tank, wherein the drum moves, to the body during transportation. DE 10 2005 009 230 discloses a laundry dryer with a tensioning device for centralising a drum placed on rollers.

**[0004]** The aim of the present invention is the realization of a laundry dryer comprising a transportation safety member which prevents the drum from being damaged during transportation.

**[0005]** The laundry dryer realized in order to attain the aim of the present invention, explicated in the first claim and the respective claims thereof, comprises a body, a drum, more than one roller which provides the drum to be borne, and a frame whereon the rollers rotating by means of the drum are mounted. The laundry dryer of the present invention comprises a transportation safety member having two positions. When the laundry dryer is to be transported, the transportation safety member is changed from the first position wherein it does not contact the drum to the second position wherein it separates the drum from the rollers by contacting the drum.

**[0006]** In an embodiment of the present invention, the transportation safety member pushes the drum upwards. Thus, the drum is separated from the rollers whereon it is seated and the drum is secured against possible impacts it may be subjected to in cases such as storing and transporting the laundry dryer.

**[0007]** In an embodiment of the present invention, the transportation safety member comprises a shaft with a toothed part thereon, a resting member which is located at the shaft end facing the drum, and a head allowing the screwing process of the shaft to be performed by being rotated inside the guide. Thus, the control of the transportation safety member is easily realized.

**[0008]** In a derivative of this embodiment, the resting member has the same shape as the portion it touches the drum. Thus, the transportation safety member can lift the drum without deforming it.

**[0009]** In a derivative of this embodiment, the transportation safety member has a resting member produced from elastomeric material. Thus, the production cost of the resting member decreases.

**[0010]** In an embodiment of the present invention, the

laundry dryer comprises a guide having a screw hole wherein the transportation safety member moves. Thus, since the transportation safety member moves inside the guide at intervals of a screw pitch, the force to be applied onto the drum is provided to be controllable.

**[0011]** In a derivative of this embodiment, during its movement inside the guide, the head of the transportation safety member bears against the stopper after the drum is separated from the rollers. Thus, the transportation safety member is prevented from being moved by the user more than desired and also, the drum is prevented from moving upwards more than desired.

**[0012]** In a derivative of this embodiment, an opening, which allows access to the transportation safety member through the base of the body, is arranged in the laundry dryer.

**[0013]** In another embodiment of the present invention, the guide is positioned near one of the front corners of the body base. In this embodiment, the guide is not placed right below the drum but near the front corner of the body base eccentrically with respect to the vertical axis passing through the center of the drum. Thus, the magnitude of the force component applied by the transportation safety member towards the center of the drum is reduced and the drum is prevented from being damaged.

**[0014]** In another embodiment of the present invention, the laundry dryer comprises two guides arranged at the front corners of the body base and two transportation safety members inserted into those guides. Thus, the force acting on by means of the transportation safety member is dispersed and the convex shape of the drum is preserved.

**[0015]** The model embodiments relating to a laundry dryer realized in order to attain the aim of the present invention are illustrated in the attached figures, where:

Figure 1 - is the schematic view of a laundry dryer.

Figure 2 - is the view of detail A in Figure 1 when the transportation safety member is in the first position.

Figure 3 - is the view of detail A in Figure 1 when the transportation safety member is in the second position.

Figure 4 - is the schematic view of a drum and a transportation safety member when the transportation safety member is in the first position in an embodiment of the present invention.

Figure 5 - is the schematic view of a guide in an embodiment of the present invention.

**[0016]** The elements illustrated in the figures are numbered as follows:

1. Laundry dryer
2. Body
3. Drum
4. Roller
5. Frame

6. Transportation safety member
7. Shaft
8. Resting member
9. Head
10. Guide
11. Stopper
12. Opening

**[0017]** The laundry dryer (1) comprises

- a body (2),
- a drum (3) which rotates around the horizontal axis and wherein items to be dried are placed,
- more than one roller (4) whereon the drum (3) is seated and which supports the drum (3) by rotating around their own axes by the movement of the drum (3) during the drying process, and
- a frame (5) whereon the rollers (4) are rotatably mounted.

**[0018]** The laundry dryer (1) of the present invention comprises a transportation safety member (6) which has a first position wherein it does not contact the drum (3) and a second position wherein it contacts the drum (3) by being moved and provides the contact of the drum (3) with the rollers (4) to be broken (Figure 1).

**[0019]** When the laundry dryer (1) is to be transported, in order to provide the safety of the laundry dryer (1), the position of the transportation safety member (6) is changed so as to provide a certain distance (D) between the drum (3) and the rollers (4). The user first positions the laundry dryer (1) so as to allow access to the transportation safety member (6) and then provides the movement of the transportation safety member (6) inside the laundry dryer (1) by moving the transportation safety member (6). After the transportation safety member (6) contacts the drum (3) and separates the drum (3) from the rollers (4) as much as a certain distance (D), the laundry dryer (1) becomes ready for the transportation process (Figure 3).

**[0020]** When the laundry dryer (1) reaches the place to be transported, the transportation safety member (6) is changed from the second position to the first position. In this position, the drum (3) contacts the rollers (4). The laundry dryer (1) is positioned such that the transportation safety member (6) can be reached and then, by moving the transportation safety member (6), the drum (3) is provided to be seated onto the rollers (4) by means of the transportation safety member (6) (Figure 2).

**[0021]** In an embodiment of the present invention, the laundry dryer (1) comprises the transportation safety member (6) which moves the drum (3) upwards while being brought from the first position to the second position. Thus, the drum (3) is lifted upwards during transportation and by breaking the contact of the drum (3) with the rollers (4) damages that may occur if the laundry dryer (1) falls down are prevented.

**[0022]** In an embodiment of the present invention, the

transportation safety member (6) comprises a screw-shaped shaft (7) extending from the body (2) towards the drum (3), a resting member (8) which is located at the shaft (7) end facing the drum (3) and contacts the drum (3) when the transportation safety member (6) is in the second position, and a head (9) which is located at the lower end of the shaft (7) and allows the shaft (7) to be rotated. Thus, the pressure acting on the drum (3) by the resting member (8) is reduced and the drum (3) is prevented from being deformed due to the force applied onto the drum (3), and the distance between the transportation safety member (6) and the drum (3) is adjusted by means of the head (9) (Figure 4).

**[0023]** In a derivative of this embodiment, the transportation safety member (6) comprises a resting member (8) having the same shape as the portion it contacts the drum (3). Thus, the resting member (8) uniformly contacts the drum (3).

**[0024]** In a derivative of this embodiment, the laundry dryer (1) comprises the transportation safety member (6) which has a resting member (8) produced from elastomeric material. By means of the elastomeric material, the drum (3) is not damaged at the moment the resting member (8) contacts the drum (3), for example, in case that the drum (3) moves and falls down onto the resting member (8) during transportation.

**[0025]** In an embodiment of the present invention, the laundry dryer (1) comprises a guide (10) which is located between the body (2) and the drum (3) and has a screw hole providing the shaft (7) of the transportation safety member (6) to be borne. Thus, the screw-shaped shaft (7) can be moved inside the guide (10) in the desired distance (Figure 4, Figure 5).

**[0026]** In a derivative of this embodiment, the laundry dryer (1) comprises a stopper (11) which is located on the guide (10) and prevents the shaft (7) from leaving the guide (10) after the shaft (7) moves towards the drum (3), and the transportation safety member (6) which has a head (9) having a diameter greater than that of the shaft (7) so as to allow the transportation safety member (6) to be stopped by bearing against the stopper (11). Thus, the movement of the transportation safety member (6) inside the guide (10) is limited after the drum (3) is separated from the rollers (4) and the drum (3) is prevented from hitting the upper surface of the frame (5) (Figure 4).

**[0027]** In a derivative of this embodiment, the laundry dryer (1) comprises an opening (12) which is arranged on the body (2) at the level of the guide (10) and allows the transportation safety member (6) to be placed into the guide (10). Thus, the position of the transportation safety member (6) can be changed by reaching into the guide (10) through the opening (12).

**[0028]** In a derivative of this embodiment, the laundry dryer (1) comprises the guide (10) which is positioned near one of the front corners of the body base (T). Thus, the transportation safety member (6) can be reached easily by bringing the laundry dryer (1) to a half-angled position.

**[0029]** In a derivative of this embodiment, the laundry dryer (1) comprises two guides (10) located near the front corners of the body base (T) and two transportation safety members (6) mounted to the guides (10). Thus, it is possible to lift the drum (3) in a balanced manner and separate it from the rollers (4).

**[0030]** The laundry dryer (1) of the present invention comprises a transportation safety member (6) that can have two positions. By changing the transportation safety member (6) to the second position, the drum (3) is separated from the rollers (4) it is seated on. Thus, the safety of the laundry dryer (1) during transportation is provided.

**[0031]** It is to be understood that the present invention is not limited to the embodiments disclosed above and a person skilled in the art can easily introduce different embodiments. These should be considered within the scope of the protection postulated by the claims of the present invention.

## Claims

### 1. A laundry dryer (1) comprising

- a body (2),
- a drum (3) which rotates around the horizontal axis and wherein items to be dried are placed,
- more than one roller (4) whereon the drum (3) is seated and which support the drum (3) by rotating around their own axes by the movement of the drum (3) during the drying process, and
- a frame (5) whereon the rollers (4) are rotatably mounted,

#### characterized by

- a transportation safety member (6) which has a first position wherein it does not contact the drum (3) and a second position wherein it contacts the drum (3) by being moved and provides the contact of the drum (3) with the rollers (4) to be broken

2. A laundry dryer (1) as in Claim 1, **characterized by** the transportation safety member (6) which moves the drum (3) upwards while being brought from the first position to the second position.

3. A laundry dryer (1) as in any one of the above claims, **characterized by** the transportation safety member (6) that comprises a shaft (7) which extends from the body (2) towards the drum (3), a resting member (8) which is located at the shaft (7) end facing the drum (3) and contacts the drum (3) when the transportation safety member (6) is in the second position, and a head (9) which is located at the lower end of the shaft (7) and allows the shaft (7) to be rotated.

4. A laundry dryer (1) as in Claim 3, **characterized by** the transportation safety member (6) which comprises

a resting member (8) having the same shape as the portion of the drum, where it contacts the drum (3).

5. A laundry dryer (1) as in Claim 3 or 4, **characterized by** the transportation safety member (6) which comprises a resting member (8) produced from elastomeric material.

6. A laundry dryer (1) as in any one of the above claims, **characterized by** a guide (10) which is located between the body (2) and the drum (3) and has a screw hole providing the transportation safety member (6) to be borne.

7. A laundry dryer (1) as in Claim 6, **characterized by** a stopper (11) which is located on the guide (10) and prevents the shaft (7) from leaving the guide (10) after the shaft (7) moves towards the drum (3), and the transportation safety member (6) which has the head (9) having a diameter greater than that of the shaft (7) so as to allow the transportation safety member (6) to be stopped by bearing against the stopper (11).

8. A laundry dryer (1) as in Claim 6 or 7, **characterized by** an opening (12) which is arranged on the body (2) at the level of the guide (10) and allows the transportation safety member (6) to be placed into the guide (10).

9. A laundry dryer (1) as in any one of the Claims 6 to 8, **characterized by** the guide (10) which is positioned near one of the front corners of the body base (T).

10. A laundry dryer (1) as in any one of the Claims 6 to 9, **characterized by** two guides (10) which are located near the front corners of the body base (T).

## Patentansprüche

### 1. Wäschetrockner (1), umfassend

- einen Gehäusekörper (2),
  - eine Trommel (3), die sich um die horizontale Achse dreht und in die zu trocknende Artikel gegeben werden,
  - mehrere Rollen (4), auf denen die Trommel (3) sitzt und die die Trommel (3) tragen, indem sie sich durch die Bewegung der Trommel (3) während des Trocknungsvorgangs um ihre eigene Achse drehen, und
  - einen Rahmen (5), an dem die Rollen (4) drehbar angebracht sind,
- gekennzeichnet durch**
- ein Transportsicherheitselement (6), das eine

- erste Position, in der es nicht in Kontakt mit der Trommel (3) steht, und eine zweite Position aufweist, in der es in Kontakt mit der Trommel (3) steht, indem es bewegt wird, und das dafür sorgt, dass der Kontakt der Trommel (3) mit den Rollen (4) unterbrochen wird.
2. Wäschetrockner (1) nach Anspruch 1, **dadurch gekennzeichnet, dass** das Transportsicherheitselement (6) die Trommel (3) aufwärts bewegt, während es aus der ersten Position in die zweite Position gebracht wird.
3. Wäschetrockner (1) nach einem der vorangehenden Ansprüche, **dadurch gekennzeichnet, dass** das Transportsicherheitselement (6) eine Welle (7), die sich vom Gehäusekörper (2) zu der Trommel (3) erstreckt, ein Ruheelement (8), das an dem Ende der Welle (7) angeordnet ist, das der Trommel (3) zugewandt ist, und das in Kontakt mit der Trommel (3) steht, wenn das Transportsicherheitselement (6) in der zweiten Position ist, und einen Kopf (9) umfasst, der am unteren Ende der Welle (7) angeordnet ist und ein Drehen der Welle (7) ermöglicht.
4. Wäschetrockner (1) nach Anspruch 3, **dadurch gekennzeichnet, dass** das Transportsicherheitselement (6) ein Ruheelement (8) umfasst, das die gleiche Form wie der Abschnitt der Trommel aufweist, an dem es in Kontakt mit der Trommel (3) steht.
5. Wäschetrockner (1) nach Anspruch 3 oder 4, **dadurch gekennzeichnet, dass** das Transportsicherheitselement (6) ein Ruheelement (8) umfasst, das aus einem Elastomermaterial hergestellt ist.
6. Wäschetrockner (1) nach einem der vorangehenden Ansprüche, **gekennzeichnet durch** eine Führung (10), die zwischen dem Gehäusekörper (2) und der Trommel (3) angeordnet ist und ein Schraubloch aufweist, das dafür sorgt, dass das Transportsicherheitselement (6) getragen wird.
7. Wäschetrockner (1) nach Anspruch 6, **gekennzeichnet durch** einen Anschlag (11), der an der Führung (10) angeordnet ist und verhindert, dass die Welle (7) die Führung (10) verlässt, wenn sich die Welle (7) zur Trommel (3) bewegt hat, und **dadurch**, dass der Kopf (9) des Transportsicherheitselements (6) einen Durchmesser aufweist, der größer als derjenige der Welle (7) ist, damit das Transportsicherheitselement (6) **durch** Anlage an den Anschlag (11) angehalten werden kann.
8. Wäschetrockner (1) nach Anspruch 6 oder 7, **gekennzeichnet durch** eine Öffnung (12), die an dem Gehäusekörper (2) auf der Höhe der Führung (10) angeordnet ist und es ermöglicht, dass das Transportsicherheitselement (6) in der Führung (10) angeordnet wird.
9. Wäschetrockner (1) nach einem der Ansprüche 6 bis 8, **dadurch gekennzeichnet, dass** die Führung (10) in der Nähe von einer der Vorderecken der Gehäusekörperbasis (T) angeordnet ist.
10. Wäschetrockner (1) nach einem der Ansprüche 6 bis 9, **gekennzeichnet durch** zwei Führung (10), die in der Nähe der Vorderecken der Gehäusekörperbasis (T) angeordnet sind.

## 15 Revendications

1. Un sèche-linge (1) comprenant
- un corps (2),
  - un tambour (3) dans lequel le linge à sécher est placé et qui est tourné autour de l'axe horizontal,
  - plus d'une roulette (4) sur laquelle le tambour (3) est placé et qui supporte le tambour (3) en tournant autour de son propre axe par le mouvement du tambour (3) pendant le processus de séchage, et
  - un cadre (5) sur lequel les roulettes (4) sont montées de manière rotative,
- caractérisé par**
- un élément de sécurité de transport (6) qui présente une première position où il ne touche pas le tambour (3) et une deuxième position où il touche le tambour (3) en étant déplacé et permet l'interruption du contact du tambour (3) avec les roulettes (4).
2. Un sèche-linge (1) selon la Revendication 1, **caractérisé par** l'élément de sécurité de transport (6) qui déplace le tambour (3) vers le haut en étant amené de la première position à la deuxième position.
3. Un sèche-linge (1) selon l'une quelconque des revendications précédentes, **caractérisé par** l'élément de sécurité de transport (6) qui comprend un arbre (7) s'étendant à partir du corps (2) vers le tambour (3), un élément de support (8) qui est situé sur l'extrémité de l'arbre (7) en face du tambour (3) et qui touche le tambour (3) pendant que l'élément de sécurité de transport (6) est dans la deuxième position, et une tête (9) qui est située à l'extrémité inférieure de l'arbre (7) et qui permet la rotation de l'arbre (7).
4. Un sèche-linge (1) selon la Revendication 3, **caractérisé par** l'élément de sécurité de transport (6) qui comprend un élément de support (8) ayant la même forme que la partie du tambour où il touche le tam-

bour (3).

5. Un sèche-linge (1) selon la Revendication 3 ou 4, **caractérisé par** l'élément de sécurité de transport (6) qui comprend un élément de support (8) produit d'un matériau en élastomère. 5
  
6. Un sèche-linge (1) selon l'une quelconque des revendications précédentes, **caractérisé par** un guide (10) qui est situé entre le corps (2) et le tambour (3) et qui présente un trou de vis permettant à l'élément de sécurité de transport (6) d'être supporté. 10
  
7. Un sèche-linge (1) selon la Revendication 6, **caractérisé par** une butée (11) qui est située sur le guide (10) et qui empêche l'arbre (7) de sortir du guide (10) après que l'arbre (7) se déplace vers le tambour (3), et l'élément de sécurité de transport (6) qui présente la tête (9) ayant un diamètre supérieur à celui de l'arbre (7) de manière à permettre à l'élément de sécurité de transport (6) d'être arrêté en s'appuyant sur la butée (11). 15  
20
  
8. Un sèche-linge (1) selon la Revendication 6 ou 7, **caractérisé par** une ouverture (12) qui est arrangée sur le corps (2) au niveau du guide (10) et qui permet à l'élément de sécurité de transport (6) d'être placé dans le guide (10). 25
  
9. Un sèche-linge (1) selon l'une quelconque des revendications de 6 à 8, **caractérisé par** le guide (10) qui est positionné près de l'un des coins avant de la base (T) du corps. 30
  
10. Un sèche-linge (1) selon l'une quelconque des revendications de 6 à 9, **caractérisé par** deux guides (10) qui sont situés près des coins avant de la base (T) du corps. 35

40

45

50

55

Figure 1

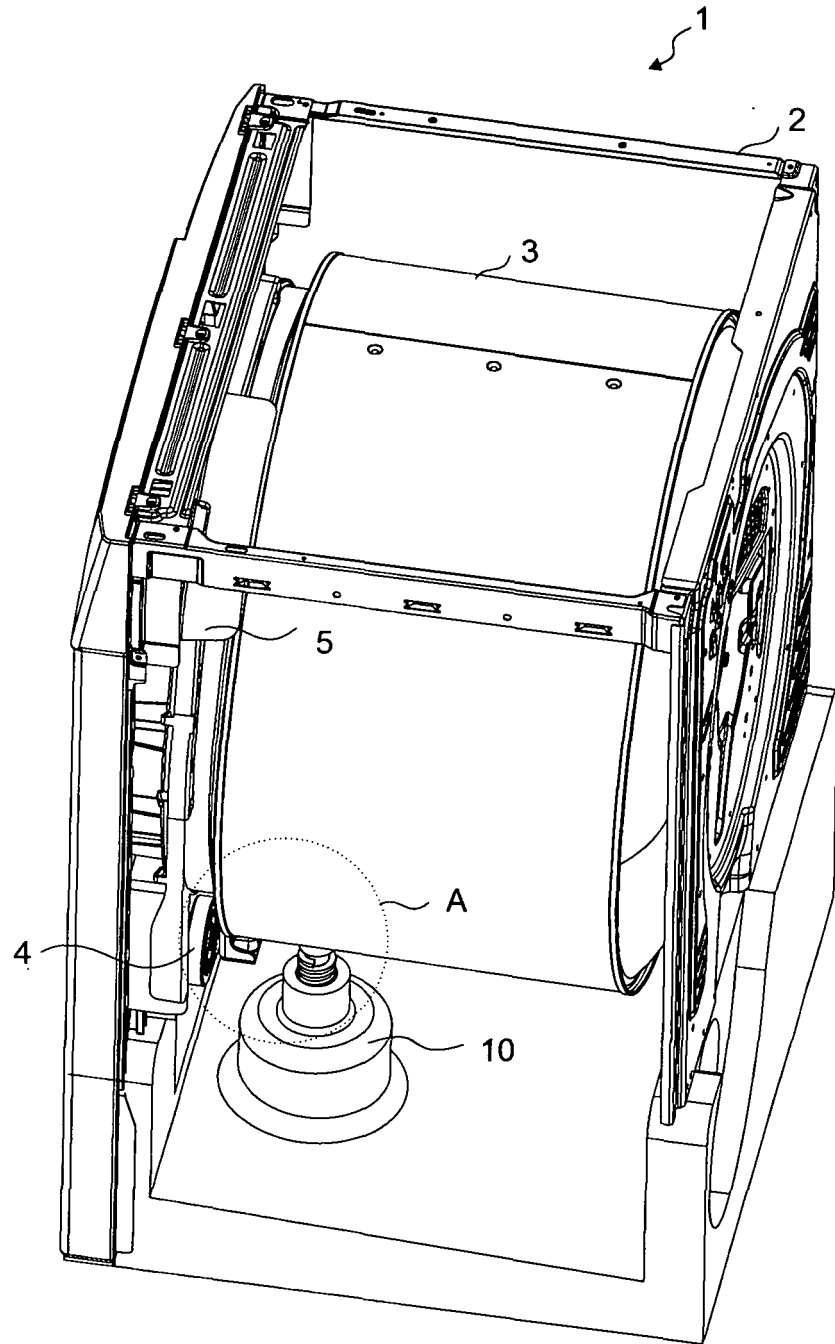

Figure 2

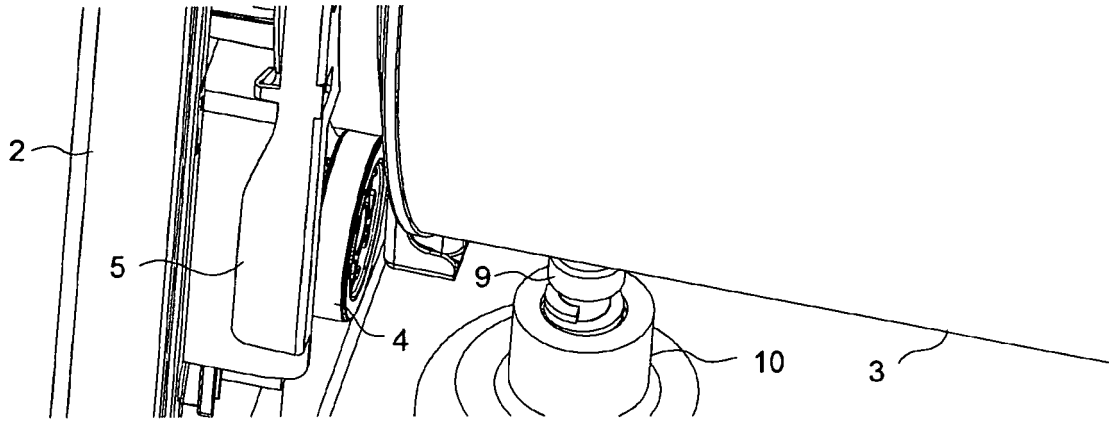

Figure 3

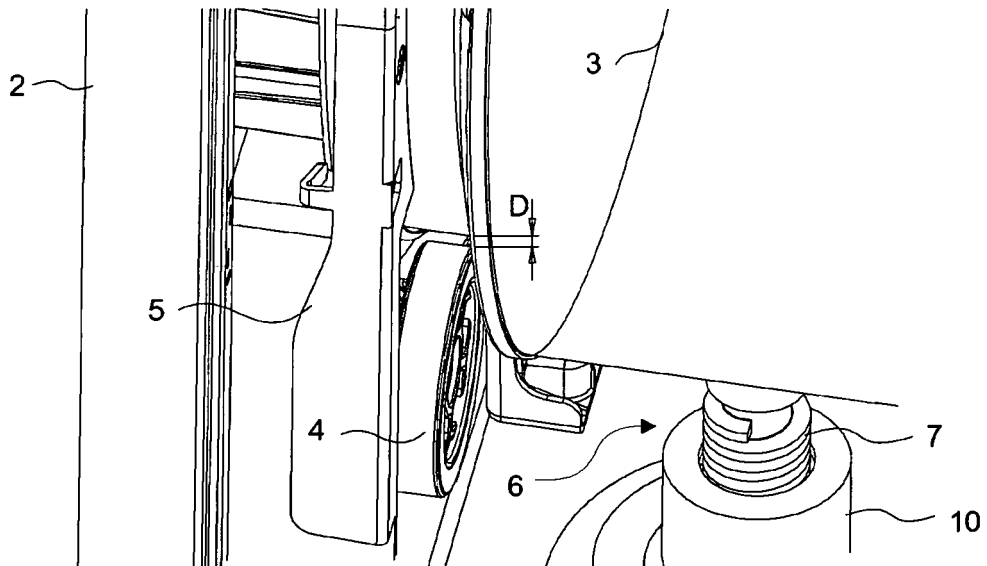

Figure 4

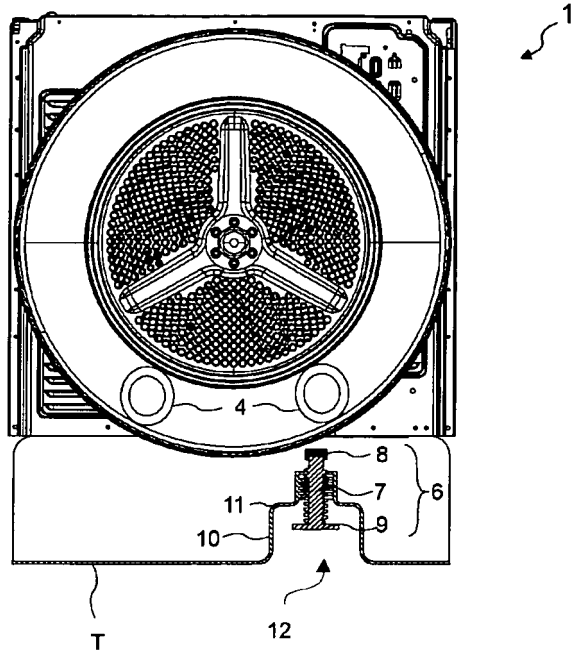
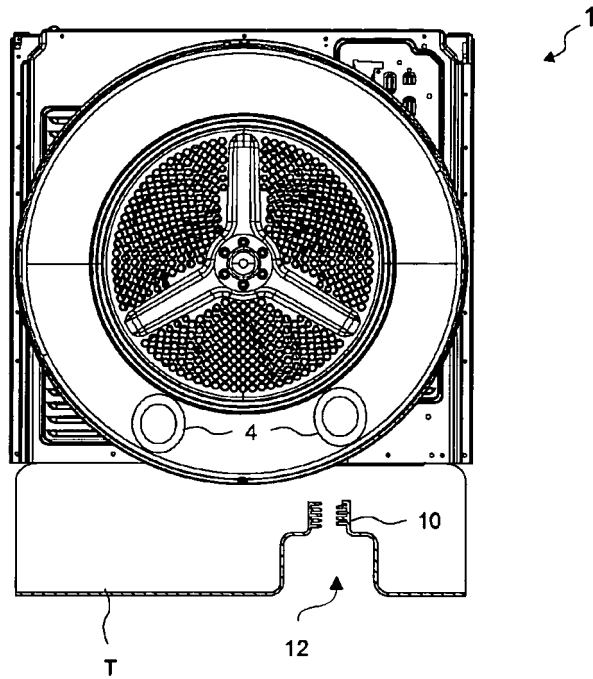

Figure 5



**REFERENCES CITED IN THE DESCRIPTION**

*This list of references cited by the applicant is for the reader's convenience only. It does not form part of the European patent document. Even though great care has been taken in compiling the references, errors or omissions cannot be excluded and the EPO disclaims all liability in this regard.*

**Patent documents cited in the description**

- EP 1702097 A [0003]
- DE 102005009230 [0003]