

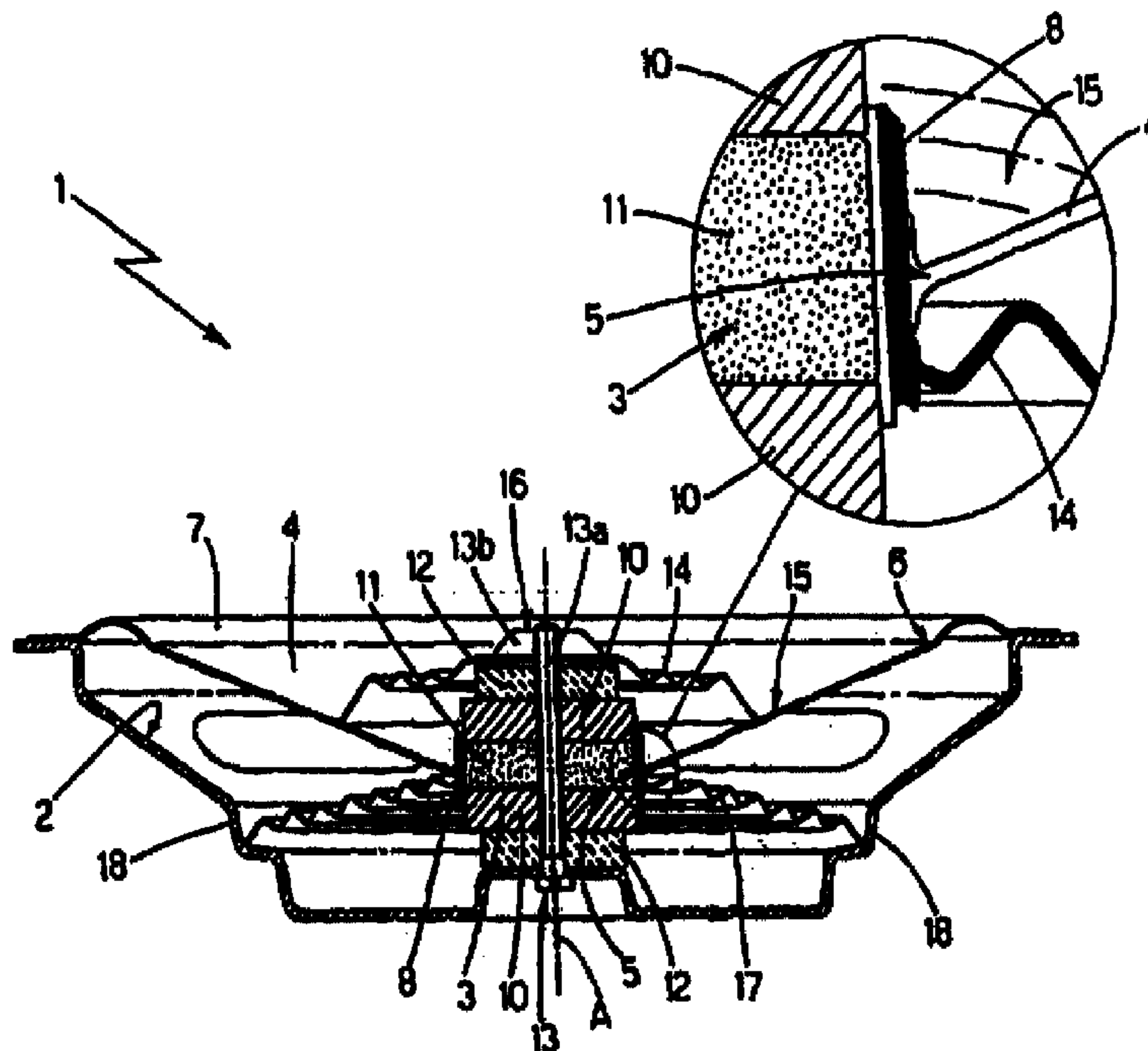

(72) DI SUMMA, FRANCESCO, IT  
(71) MACKLAINE DI FRANCESCO DI SUMMA E C. S.N.C., IT  
(51) Int.Cl.<sup>6</sup> H04R 9/06  
(30) 1997/11/06 (BO97A000658) IT  
(54) **HAUT-PARLEUR A BOBINE MOBILE**  
(54) **MOVING-COIL LOUDSPEAKER**



(57) L'invention concerne un haut-parleur qui comporte un saladier (2) cupuliforme, un corps magnétique (3) s'étendant à l'intérieur du saladier (2) et monté coaxialement par rapport à un axe longitudinal (A) de ce dernier, une membrane (4) de forme sensiblement tronconique montée dans l'axe du corps magnétique (3) et coulissant par rapport à celui-ci et une bobine de commande (8) montée dans l'axe du corps magnétique (3), coulissant par rapport à celui-ci et intégrée à la membrane (4). Le haut-parleur (1) comporte également une première membrane d'amortissement (14) et de centrage annulaire reliant le corps magnétique (3) à la membrane (4) et une seconde membrane d'amortissement (17) et de centrage annulaire reliant la bobine (8) à la paroi latérale (18) du saladier (2).

(57) A loudspeaker (1) having a substantially cup-shaped frame (2); a magnetic body (3) extending inside the frame (2) and coaxial with a longitudinal axis (A) of the frame (2); a substantially truncated-cone-shaped diaphragm (4) fitted in axially-sliding manner to the magnetic body (3); and an actuating coil (8) fitted in axially-sliding manner to the magnetic body (3) and integral with the diaphragm (4); the loudspeaker (1) also having a first annular centering and damping membrane (14) connecting the magnetic body (3) to the diaphragm (4); and a second annular centering and damping membrane (17) connecting the coil (8) to the lateral wall (18) of the frame (2).

PCT

WORLD INTELLECTUAL PROPERTY ORGANIZATION  
International Bureau

## INTERNATIONAL APPLICATION PUBLISHED UNDER THE PATENT COOPERATION TREATY (PCT)

<p>(51) International Patent Classification <sup>6</sup> : <b>H04R</b></p>	<p><b>A2</b></p>	<p>(11) International Publication Number: <b>WO 99/25149</b></p> <p>(43) International Publication Date: 20 May 1999 (20.05.99)</p>
<p>(21) International Application Number: PCT/IT98/00310</p> <p>(22) International Filing Date: 6 November 1998 (06.11.98)</p> <p>(30) Priority Data: BO97A000658 6 November 1997 (06.11.97) IT</p> <p>(71) Applicant (for all designated States except US): MACKLAINE DI FRANCESCO DI SUMMA E C. S.N.C. [IT/IT]; Via Mentana, 69, I-48022 Lugo (IT).</p> <p>(72) Inventor; and (75) Inventor/Applicant (for US only): DI SUMMA, Francesco [IT/IT]; Via Mentana, 68, I-48022 Lugo (IT).</p> <p>(74) Agents: JORIO, Paolo et al.; Studio Torta S.r.l., Via Viotti, 9, I-10121 Torino (IT).</p>		<p>(81) Designated States: AL, AM, AT, AU, AZ, BA, BB, BG, BR, BY, CA, CH, CN, CU, CZ, DE, DK, EE, ES, FI, GB, GE, GH, GM, HR, HU, ID, IL, IS, JP, KE, KG, KP, KR, KZ, LC, LK, LR, LS, LT, LU, LV, MD, MG, MK, MN, MW, MX, NO, NZ, PL, PT, RO, RU, SD, SE, SG, SI, SK, SL, TJ, TM, TR, TT, UA, UG, US, UZ, VN, YU, ZW, ARIPO patent (GH, GM, KE, LS, MW, SD, SZ, UG, ZW), Eurasian patent (AM, AZ, BY, KG, KZ, MD, RU, TJ, TM), European patent (AT, BE, CH, CY, DE, DK, ES, FI, FR, GB, GR, IE, IT, LU, MC, NL, PT, SE), OAPI patent (BF, BJ, CF, CG, CI, CM, GA, GN, GW, ML, MR, NE, SN, TD, TG).</p> <p><b>Published</b> Without international search report and to be republished upon receipt of that report.</p>

(54) Title: MOVING-COIL LOUDSPEAKER

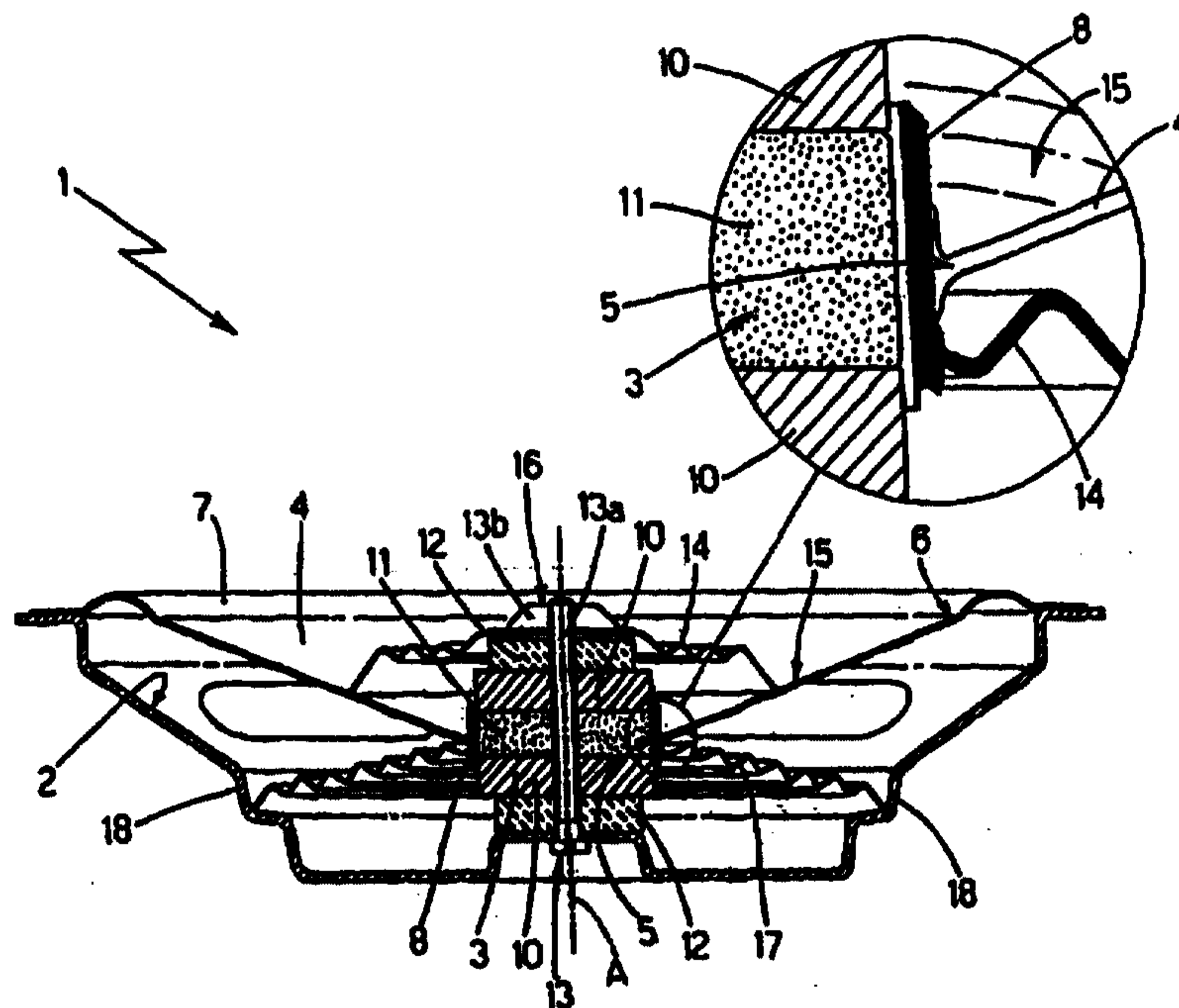

## (57) Abstract

A loudspeaker (1) having a substantially cup-shaped frame (2); a magnetic body (3) extending inside the frame (2) and coaxial with a longitudinal axis (A) of the frame (2); a substantially truncated-cone-shaped diaphragm (4) fitted in axially-sliding manner to the magnetic body (3); and an actuating coil (8) fitted in axially-sliding manner to the magnetic body (3) and integral with the diaphragm (4); the loudspeaker (1) also having a first annular centering and damping membrane (14) connecting the magnetic body (3) to the diaphragm (4); and a second annular centering and damping membrane (17) connecting the coil (8) to the lateral wall (18) of the frame (2).

5

## MOVING-COIL LOUDSPEAKER

TECHNICAL FIELD

10           The present invention relates to a moving-coil  
loudspeaker.

BACKGROUND ART

          As is known, at present, loudspeakers comprise a  
frame or basket having two coaxial portions, one  
15 truncated-cone-shaped and the other cylindrical; a  
magnetic body housed coaxially with the frame axis inside  
the cylindrical portion of the frame; a cone or diaphragm  
housed in axially-movable manner inside the truncated-  
cone-shaped portion of the frame, with the smaller  
20 peripheral edge coaxial with the magnetic body, and the  
larger peripheral edge connected to the frame by an  
elastic annular membrane; and an actuating coil fitted to  
the smaller peripheral edge of the cone so as to slide on  
the magnetic body.

25           Known loudspeakers also comprise an elastic  
centering and damping membrane connecting the actuating  
coil to the cylindrical portion of the frame to keep the

- 2 -

coil coaxial with the magnetic body as the cone moves axially; and a protective cap fitted to the cone to cover and protect the portion of the magnetic body projecting inside the cone.

5           The loudspeaker frame must obviously be so sized as to prevent the protective cap fitted to the cone from knocking against the magnetic body when the cone is backed up inside the frame by the forces generated in the coil by the interaction of the magnetic field and the  
10 electric current circulating in the coil.

A major drawback of the above structure lies in the total height of the loudspeaker, i.e. the length measured along the frame axis, not being reducible below a minimum value depending on the axial size of the magnetic body  
15 and on the size and maximum axial travel of the cone; which limitation runs counter to current market demand for increasingly shorter loudspeakers for a given acoustic efficiency.

#### DISCLOSURE OF INVENTION

20           It is an object of the present invention to provide a loudspeaker designed to enable a reduction in total height below present limits.

          According to the present invention, there is provided a moving-coil loudspeaker comprising a  
25 substantially cup-shaped frame; a magnetic body fitted integrally to the frame and inside the frame itself; a diaphragm fitted movably inside said frame; and an

- 3 -

actuating coil fitted integrally to the diaphragm and in sliding manner to said magnetic body; said loudspeaker being characterized by comprising a first annular centering and damping membrane connecting said diaphragm to said magnetic body.

#### BRIEF DESCRIPTION OF THE DRAWINGS

A non-limiting embodiment of the present invention will be described by way of example with reference to the accompanying drawings, in which:

10 Figure 1 shows a section, with parts removed for clarity, of a loudspeaker in accordance with the teachings of the present invention;

Figures 2, 3 and 4 show sections of respective variations of the Figure 1 loudspeaker.

#### BEST MODE FOR CARRYING OUT THE INVENTION

15 Number 1 in Figure 1 indicates as a whole a loudspeaker comprising a substantially cup-shaped frame 2; a magnetic body 3 fitted to the bottom of frame 2 and coaxial with axis A of frame 2; and a cone or diaphragm 4  
20 housed coaxially with axis A inside frame 2, with the smaller peripheral edge 5 facing and coaxial with magnetic body 3, and with the larger peripheral edge 6 at the opening of frame 2.

Loudspeaker 1 also comprises an elastic annular  
25 supporting membrane 7 connecting the larger peripheral edge 6 of cone 4 to the edge defining the opening of frame 2; and an actuating coil 8 fitted in sliding manner

to magnetic body 3 and fitted to the smaller peripheral edge 5 of cone 4. Elastic annular membrane 7 is so formed as to permit axial displacement of cone 4, and coil 8 is immersed in the magnetic field generated by magnetic body 3, so that cone 4 is moved axially inside frame 2 by the forces generated by the interaction of the magnetic field and any electric current circulating in coil 8. Electric current is supplied to coil 8 by two terminals (not shown) made of electrically conducting material.

10 In the example shown, coil 8 comprises four layers of electrically conducting wire wound about a cylindrical tubular element fitted in sliding manner to magnetic body 3.

With reference to Figure 1, frame 2 is substantially truncated-cone-shaped and preferably, though not necessarily, made of nonferromagnetic material.

Magnetic body 3 is substantially cylindrical, and comprises two substantially tablet-shaped permanent magnets 10, and a spacer washer 11 made of ferromagnetic material and interposed between the two permanent magnets 10 to form a stack coaxial with axis A. Permanent magnets 10 are magnetized in a direction parallel to axis A, and are stacked with similar poles facing spacer washer 11.

25 In the example shown, magnetic body 3 comprises a further two washers 12 preferably, though not necessarily, made of nonferromagnetic material, and which

- 5 -

are arranged coaxial with axis A and each contacting a respective permanent magnet 10.

In the example shown, magnetic body 3 is fitted to frame 2 by a lock bolt 13, which comprises a screw 13a  
5 extending coaxially with axis A through the bottom wall of frame 2 and through washers 12, magnets 10 and spacer washer 11; and a nut 13b screwed to the end of screw 13a. Besides fitting magnetic body 3 integrally to frame 2, bolt 13 also prevents the stack defined by washers 12,  
10 magnets 10 and spacer washer 11 from being parted by the tendency of the two permanent magnets 10 to repel each other.

Loudspeaker 1 also comprises a first centering membrane 14 connecting the inner surface 15 of cone 4 to  
15 the free end 16 of magnetic body 3; and a second centering membrane 17 connecting coil 8, i.e. cone 4, to the lateral wall 18 of frame 2. Both centering membranes 14 and 17 are so formed as to only permit axial displacement of cone 4 and coil 8.

20 Both centering membranes 14 and 17 also provide for damping oscillation of cone 4, and for preventing operation of loudspeaker 1 from being impaired by dirt settling in the gap between magnetic body 3 and coil 8.

In the Figure 2 variation, magnetic body 3 of  
25 loudspeaker 1 has neither of washers 12.

In the Figure 3 variation, one of washers 12 of magnetic body 3 (in Figure 3, the one interposed between

- 6 -

permanent magnet 10 and the bottom wall of frame 2) is replaced by a substantially tablet-shaped auxiliary permanent magnet 20 magnetized in a direction parallel to axis A of frame 2; and permanent magnet 10 and auxiliary permanent magnet 20 are arranged with dissimilar poles facing each other.

In the Figure 4 variation, both washers 12 are replaced by respective substantially tablet-shaped auxiliary permanent magnets 20 magnetized in a direction parallel to axis A of frame 2; and each auxiliary permanent magnet 20 and the corresponding permanent magnet 10 are arranged with dissimilar poles facing each other.

In a first variation not shown, loudspeaker 1 is without washer 12 at free end 16 of magnetic body 3, and the washer 12 interposed between permanent magnet 10 and the bottom wall of frame 2 may be replaced by an auxiliary permanent magnet similar to the one in the Figure 4 variation.

In a further variation not shown, loudspeaker 1 is without elastic centering membrane 17.

Operation of loudspeaker 1 is self-explanatory from the foregoing description.

The main advantage of loudspeaker 1 as illustrated and described above lies in magnetic body 3 extending inside and substantially the full height of frame 2, i.e. along the whole length of frame 2 measured along axis A,

- 7 -

thus enabling a considerable reduction in size. In particular, the above construction design provides for producing a loudspeaker 1 of a height approximately equal to but no less than the length of magnetic body 3 measured along axis A.

A further advantage of loudspeaker 1 lies in the mechanical stress produced by the displacement of cone 4 now being discharged by two elastic centering membranes as opposed to one, which means elastic centering membranes 14 and 17 may be made of lighter, more elastic material to improve the overall acoustic efficiency of loudspeaker 1.

A further advantage lies in the provision of washers 12, which may be either removed or replaced by auxiliary permanent magnets 20 to vary the characteristics of magnetic body 3 according to the application of loudspeaker 1.

Clearly, changes may be made to loudspeaker 1 as described and illustrated herein without, however, departing from the scope of the present invention.

## NEW SET OF AMENDED CLAIMS

1) A moving-coil loudspeaker (1) comprising a substantially cap-shaped frame (2); a magnetic body (3) fitted integrally to the frame (2) and inside the frame (2) itself; a diaphragm (4) fitted movably inside said frame (2) **in sliding manner to said magnetic body (3)**; and an actuating coil (8) fitted integrally to the diaphragm (4) and in sliding manner to said magnetic body (3); said loudspeaker (1) being characterized by comprising **a first annular centering and damping membrane (14) connecting said diaphragm (4) to a portion of said magnetic body (3) projecting inside said diaphragm (4).**

2) A moving-coil loudspeaker as claimed in Claim 1, characterized in that said diaphragm (4) is substantially truncated-cone-shaped; said first annular centering and damping membrane (14) connecting the magnetic body (3) to the **inner surface (15) of the diaphragm (4) facing the portion of the magnetic body (3) projecting inside said diaphragm (4).**

3) A moving-coil loudspeaker as claimed in Claim 1 or 2, characterized by comprising a second annular centering and damping membrane (17) connecting said frame (2) to said actuating coil (8).

4) A moving-coil loudspeaker as claimed in any one of the foregoing Claims, characterized in that said magnetic body (3) extends inside the frame (2) coaxially with a main axis (A), and comprises a spacer element (11) coaxial with said main axis (A), and two permanent magnets (10) coaxial with said main axis (A) and on opposite sides of said spacer element (11); said spacer element (11) being made of ferromagnetic material.

5) A moving-coil loudspeaker as claimed in Claim 4, characterized in that said permanent magnets (10) are substantially tablet-shaped, are

AMENDED SHEET

magnetized in a direction parallel to said main axis (A), and are arranged with similar poles facing the spacer element (11).

6) A moving-coil loudspeaker as claimed in Claim 4 or 5, characterized in that said magnetic body (3) comprises at least one washer (12) coaxial with said main axis (A) and contacting a respective permanent magnet (10); said washer (12) being made of nonferromagnetic material.

7) A moving-coil loudspeaker as claimed in any one of Claims 4, 5 and 6, characterized in that said magnetic body (3) comprises at least one auxiliary permanent magnet (20) coaxial with said main axis (A) and contacting a respective permanent magnet (10).

8) A moving-coil loudspeaker as claimed in Claim 7, characterized in that said auxiliary permanent magnet (20) is substantially tablet-shaped and is magnetized in a direction parallel to said main axis (A).

9) A moving-coil loudspeaker as claimed in any one of the foregoing Claims, characterized in that said actuating coil (8) is coaxial with said magnetic body (3) and comprises four layers of electrically conducting wire wound about a cylindrical tubular element fitted in sliding manner to said magnetic body (3).

AMENDED SHEET

1 / 2

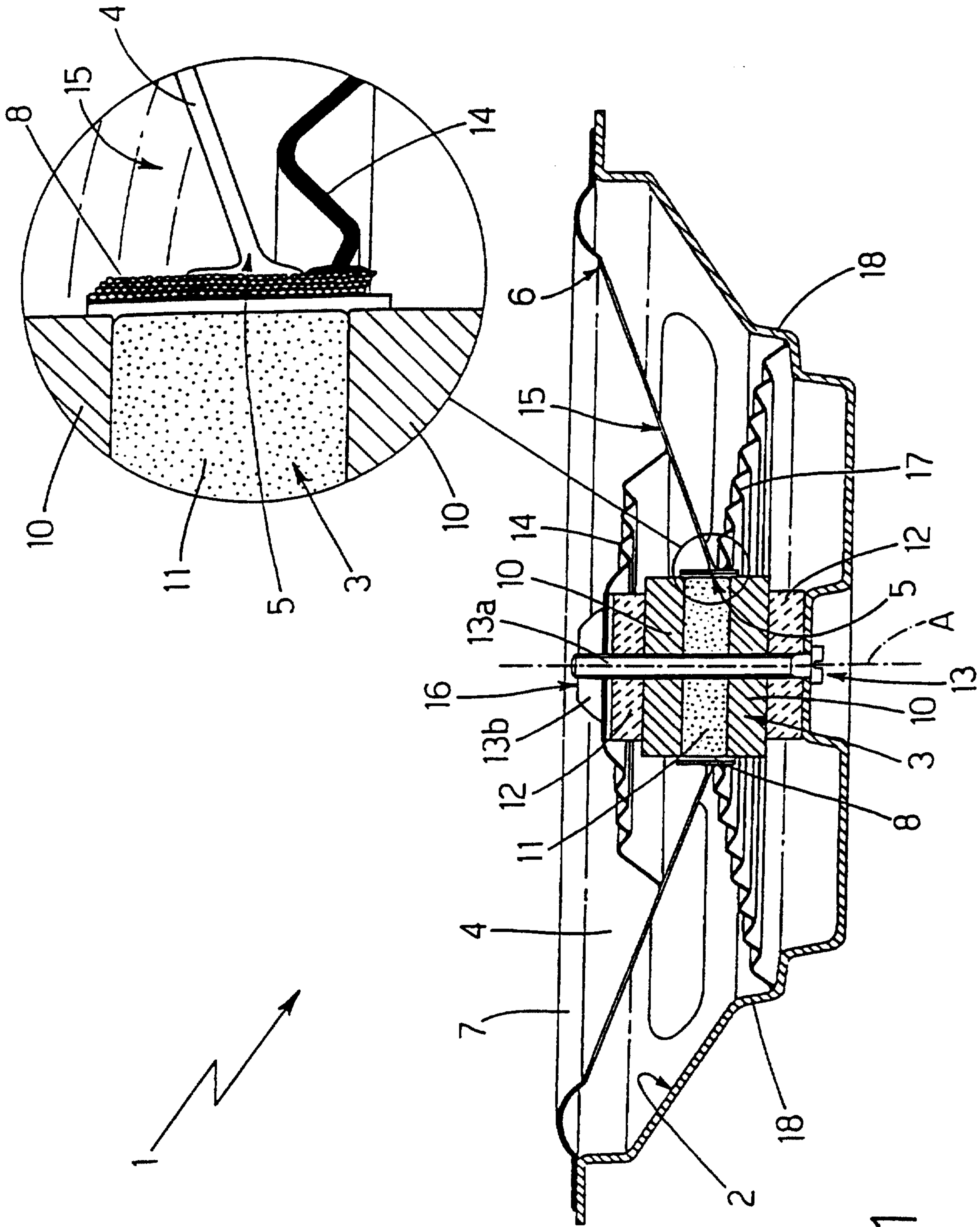

Fig.1

2 / 2

